

The ThermoGen is a universal tank-style electric coolant heater to preheat engines. It is meant for either stationary (generating sets) or mobile applications (all types of vehicles). The choice of high-quality components and materials guarantees a long-term troublefree operation of the heater. The limited weight (less than 1200 grammes) and external dimensions make it very easy to install. The circulation of the coolant is made by natural convection (thermosiphon).



TABLE OF CONTENTS

<p>1. IMPORTANT SAFETY INSTRUCTIONS: page 2</p> <p>2. SPECIFICATIONS Technical characteristics: page 3 Exploded view: page 4</p> <p>3. MOUNTING INSTRUCTIONS Unpacking and installation preparation: page 4 Precautions: page 5 Installation instructions: page 5 Connecting the coolant circuit: page 5 Electrical connections : page 6</p>	<p>4. DIRECTION FOR USE Putting the heater into service : page 7</p> <p>5. TROUBLESHOOTING: page 7</p> <p>6. INSTRUCTIONS FOR THE PROTECTION OF THE ENVIRONMENT : page 7</p> <p>7. TOTAL QUALITY: page 7</p> <p>8. WARRANTY: page 8</p>
---	--

The present user's guide contains instructions to be fulfilled during the mounting and the starting stage. Please read carefully for a correct installation and a proper use of the heater. Keep these instructions after installation.

1. IMPORTANT SAFETY INSTRUCTIONS



Qualified personnel

The mounting should be carried out by a qualified technician only.

Danger in case of non-compliance with the present guidelines

The non-compliance with present guidelines could have serious consequences for the safety of people and could damage the equipment, thus making the warranty void. The strictest rigor is required for the electrical and mechanical aspects of the mounting.

Safety measures meant for the user

Avoid any risks linked to the mains by strictly observing local safety instructions in force.

Check or have checked by an authorized technician that your electrical installation is protected by a differential current system and that the earthing is in compliance with the local safety prescriptions.

Modifications to the heater and use of unauthorized parts

Any modification to the heater will be made only in agreement with the manufacturer. The use of official spare parts and accessories guarantees your safety. The manufacturer disclaims any liability in case non-original parts are used.

Inappropriate use of the equipment

The equipment supplied with the present user guide is exclusively meant for the applications described in this user guide.

The ThermoGen is a universal tank-type electric coolant heater to preheat engines. It is meant for either stationary (generating sets) or mobile applications (all types of vehicles).

2. SPECIFICATIONS

Technical Characteristics

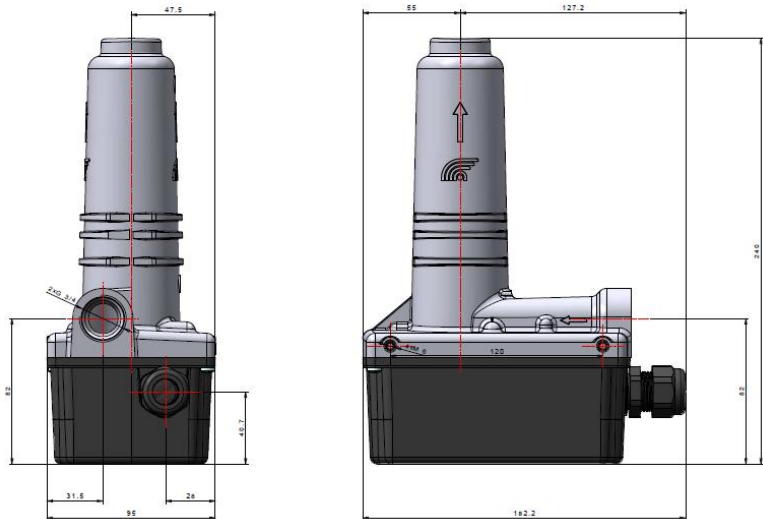
MODEL	THG
Description	The ThermoGen is a universal tank-style electric coolant heater to preheat engines. It is meant for either stationary (generating sets) or mobile applications (all types of vehicles). The circulation of the coolant is made by natural convection (thermosiphon).
Picture	
Components characteristics	
Heating body	Injected aluminium impregnated with resin
Heating element	Stainless steel protection sheat
Regulation thermostat	2 fixed temperature range available: 32°C to 40°C or 35°C to 50°C.
Safety thermostat	Optional
Electrical characteristics	
Rated voltage and frequency	230V-50 Hz / 120V-60Hz
Power/Voltage	500W / 1000W / 1500W / 2000W (230V or 120V) 3000W / 4000 W (230V only)
Amperage	From 2,17 to 17,39 Amp depending models
Working specifications	
Maximum working pressure	4 bars (58psi)
Ingress protection level	The complete heater is dust- and watertight.
Temperature range	Fixed from 32°C to 40°C (90° F to 104°F) or from 35°C to 50°C (95°F to 122°F).
General characteristics	
Weight in kg	1.2 kg
Dimensions in mm	
The inlet and outlet connectors are 3/4" BSP	

Exploded view ThermoGen

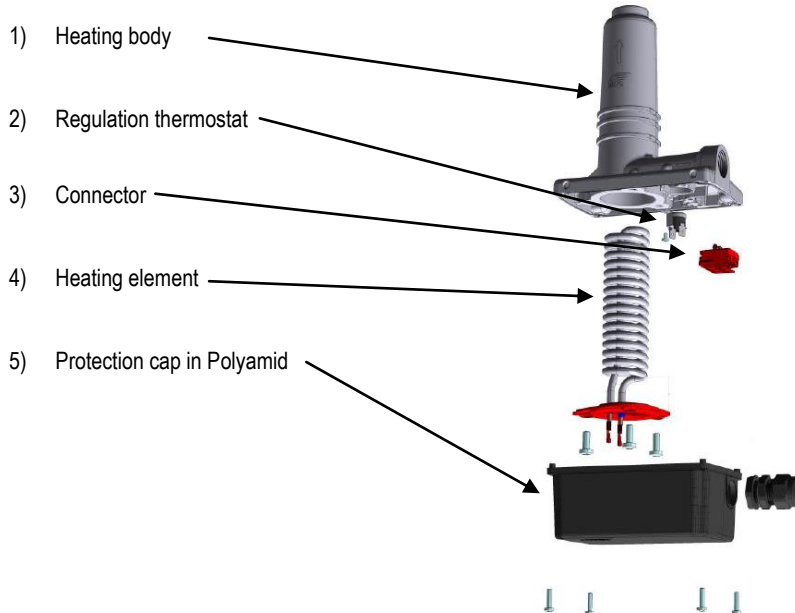

1. Heating body

Full injected aluminium construction

2. Regulation thermostat

The temperature regulating thermostat is placed at the entry of the heater. Cutting capacity: 25 amps (100.000 cycles).

The regulating thermostat has a fixed temperature range:

Available temperatures :

ON 32°C. – OFF 40°C (ON 90° F. – OFF 104°F)

ON 35°C. – OFF 50°C (ON 95°F.– OFF 122°F)

3. Connector

3 pole connexion terminal block

4. Immersed heating element

Stainless steel protection sheath and low watt density (max. 7.5 W/cm² / 1.16 W/in² → 3kW and 10W/cm² / 1,550 W/in² on 4 kW) for increased reliability.

Element formed in spiral offers more compactness, while maintaining a low watt density and improving the heat exchange with water.

Available powers are: 500 - 1000 – 1500 - 2000 Watts in 120 V or 230 V and 3000 – 4000 Watts in 230V only

The heating element is TIG welded on a flange. Watertightness is guaranteed by an O-ring NBR 70SH.

5. Protection cap in Polyamid + cable gland

3. MOUNTING INSTRUCTIONS

Unpacking and installation preparation

Make sure you have the following components and accessories before disposing of the packaging material:

For a correct installation use the spare parts and accessories delivered with the ThermoGen.

1. **ThermoGen heater** with 4 screws and 1 cable gland

2. **User guide**

Precautions

The installation has to be made by an authorized technician in strict compliance with the instructions of the manufacturer. Do not connect to the mains before having followed the present instructions. Do not connect the heater to the mains if you are not sure that it is filled with coolant.

Installation instructions

- ✓ The ThermoGen can only be mounted in vertical position
- ✓ Fix the heater as low as possible. The heater should be below the lowest level of the water jacket and the coolant inlet must be below the point of removal of the coolant from the engine.
- ✓ Fix the ThermoGen to the chassis or any other suitable place with the fixation kit supplied with the heater. If you don't use fixation kit supplied, the support for the fixing of the heater should be rigid enough.
- ✓ Be careful not to mount the heater, the hoses or the power cord close to the engine exhaust.

Connecting the coolant circuit

Drain off completely the coolant circuit.

Before placing the heater, it is imperative to drain the coolant circuit. Unscrew the drain plug or disconnect the lower hose in order to completely drain off the coolant circuit.

Connecting the heater inlet.

The heater inlet and outlet are meant for hoses (not supplied) with an internal diameter of 3/4" BSP. For engines equipped with a drain plug, replace the plug by a hose connector with an internal diameter of 3/4" BSP in order to make the connection to the heater inlet. If the heater is connected to a rigid pipe, use a piece of flexible radiator hose that is long enough to prevent engine vibrations being transmitted to the heater.

Connecting the heater outlet.

In order to guarantee an optimum heating of the engine the coolant return hose from the heater to the engine should be placed at the highest possible point on the engine and as far as possible from the suction port to enhance heat distribution throughout the engine. Use any available coolant jacket opening and install a connector for the outlet hose.

Checking and re-filling the coolant circuit

Make sure that the hose clamp collars are properly tightened. Fill the coolant circuit with a high quality and clean mixture glycol/water without impurities and without exceeding the recommended proportion 50% glycol / 50% water. It is necessary to check its quality frequently to ensure that the heater is not dirty, has no grimes and does not suffer from deterioration. The life and the proper functioning of the heater depend on it. In order to eliminate air pockets and obtain a good circulation, run the engine a few minutes. Then shut off the engine and check that the water circuit is properly flushed. Check that all connections are watertight and that hose clamps are properly tightened. When the engine has cooled down, check the level of coolant in the circuit and adjust if necessary.

Examples of Correct Mounting

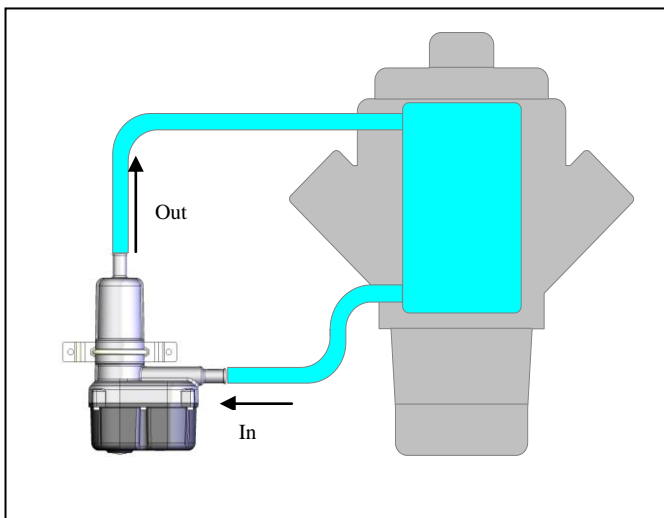

Incorrect mounting

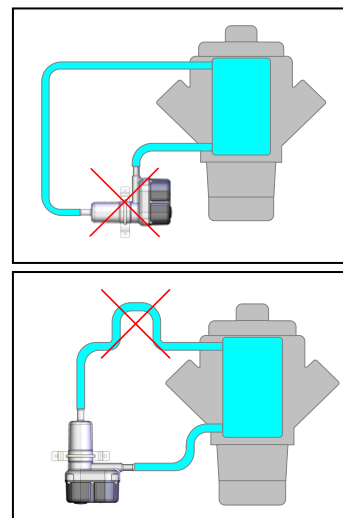

Horizontal position is not right

Curve into the tubing

Electrical connections

Fixing the power supply cord.

Fix the cord with clamp collars in order to avoid any contact with hot or moving parts. It is recommended to use a protection sheath for the cord.

Checking the installation before connecting the heater to electricity.

Check the information regarding voltage and power on the heater label before connecting the heater to electricity. An improper connection to the mains could irretrievably damage your heater. Make sure that the voltage is correct and the earthing is in compliance with local rules.



Electrical diagrams ThermoGen single-phase 120V– 230V 50 / 60 Hz

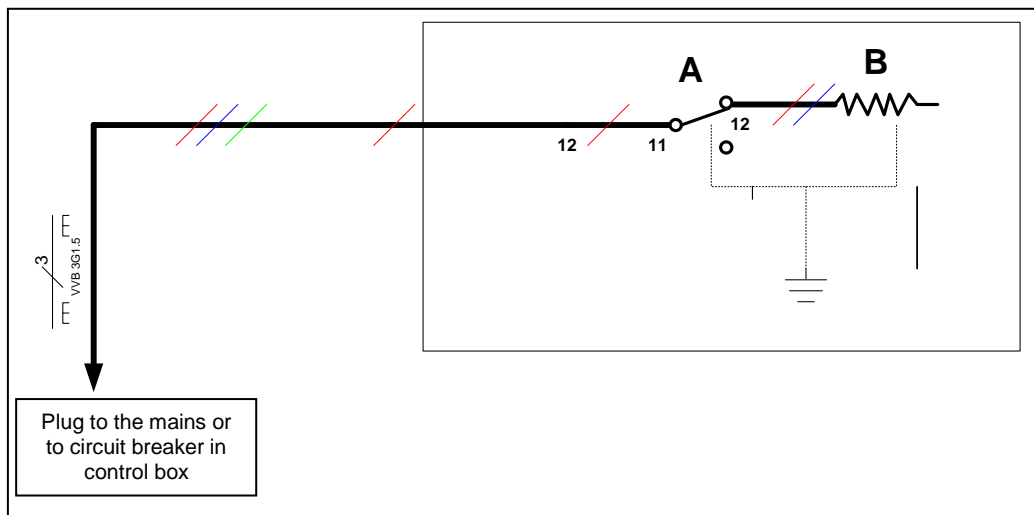

- A. Fixed temperature regulating thermostat
- B. Heating element

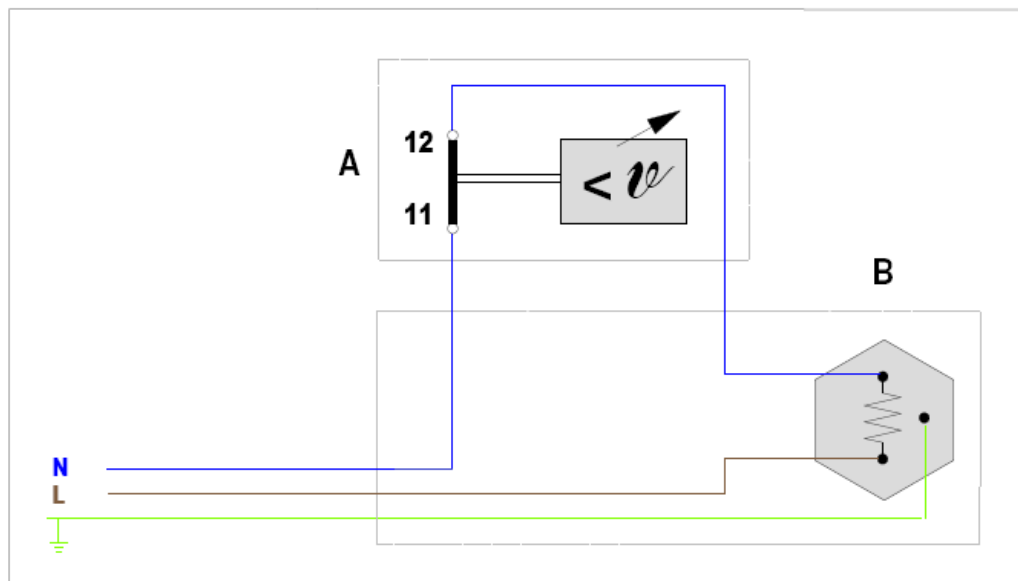



4. DIRECTIONS FOR USE

Putting the heater into service

BEWARE: DON'T START THE HEATER IF NOT FILLED WITH COOLANT

Follow the procedure described hereafter:

- Connect the plug.
- The regulating thermostat will adjust the temperature in the range from 32°C to 40°C (90° F to 104°F) or from 35°C to 50°C (95°F to 122°F).
- Touch the heater inlet and outlet hoses at regular intervals during one hour. If the heater works correctly, the outlet hose should be warm and the inlet hose relatively cold. If the inlet hose becomes very hot before the outlet hose, the circulation is not good.

5. TROUBLESHOOTING

Before contacting the technical service, please check the following table for causes and remedies:

- Contaminated cooling circuit
- Air pocket caused by a curve in the hoses
- Engine temperature higher than the thermostat set temperature.

Type of problem	Possible causes	Control and remedies
The heating body of the ThermoGen and the engine remain cold	The ThermoGen is not connected to the mains.	<ol style="list-style-type: none">1. Check that the supplying cable is connected to the mains.2. Check that the supply to the mains is correct.3. Check the fuses in the mains distribution box.
The connection to the mains is correct. The ThermoGen and the engine remain cold.	The overheat thermostat has been switched on. ⇒ Lack of water into the heater	<ol style="list-style-type: none">1. Disconnect the supplying cable from the mains.2. Reset the overheat thermostat (see above)3. Check the level of water in the circuit.4. Adjust the level if necessary.5. Turn the engine on for 10 minutes.6. Reconnect the supplying cable to the mains
The level of coolant is correct. The circuit is properly purged. The ThermoGen is hot but the engine remains cold.	Bad circulation.	<ol style="list-style-type: none">1. Check the installation. The heater is mounted too high or there is a curve into the pipe.
The fuse or the circuit breaker in the distribution box is engaged.	Electrical breakdown.	<ol style="list-style-type: none">1. Take off the supplying cable.2. Put the ThermoGen out of service and call the technical service.

6. INSTRUCTIONS FOR THE PROTECTION OF THE ENVIRONMENT

Recuperation of raw materials rather than elimination of waste. Machines, as well as their accessories and packaging, should be recycled in an appropriate way. Our spare parts can be recycled selectively depending on the type of material. Phillips & Temro Industries Europe SPRL. commits itself to recycle the different components of the ThermoGen. Each ThermoGen will be either reconditioned or recycled selectively at the Customer's request.

7. TOTAL QUALITY

Each ThermoGen assembled by Phillips & Temro Industries Europe SPRL is controlled and tested before leaving the factory.

Phillips & Temro Industries Europe SPRL runs the following test on each ThermoGen:

- Measurement of the resistance value of the heating element;
- Electrical insulation of heating element;
- Heating test;
- Test of electrical insulation of complete heater.



8. WARRANTY

All our devices ThermoGen are guaranteed against all manufacturing errors over a 2 years period, starting at the invoice date and following general sales conditions. This warranty is voided in each of the following situations:

- The device was transformed or modified without permission of Phillips & Temro Industries Europe SPRL
- Installation and use are against the guidelines of ThermoGen
- The heater is damaged by impurities or grimes.

Our warranty covers exclusively the changing of the standard installation or replacement of the damaged parts. Are not taken under warranty: wrong installation or use, costs for assembling and disassembling the heater, costs for assembling or disassembling the installation, shipment costs.

Manufactured in Belgium by:

Phillips & Temro Industries Europe SPRL
Rue du roua 70
B-4140 Sprimont
Belgique
Tel : +32 4 384 01 97 Fax : +32 4 367 16 66
info@carlor.com www.carlor.com

Phillips & Temro Industries Europe SPRL
Rue du roua 70 B-4140 Sprimont Belgique
Tél. : +32 (0)4 384 01 97 Fax : + 32 (0)4 367 16 66
www.carlor.com info@carlor.com