



DSE Genset®



DSE Ats®



DEEP SEA ELECTRONICS PLC

PLC PROGRAMMING GUIDE FOR DSE CONTROLLERS

Document Number: 057-175

Author: Anthony Manton



Deep Sea Electronics Plc
Highfield House
Hunmanby
North Yorkshire
YO14 0PH
ENGLAND

Sales Tel: +44 (0) 1723 890099
Sales Fax: +44 (0) 1723 893303

E-mail: sales@deepseapl.com
Website: www.deepseapl.com

PLC Programming Guide for DSE Controllers

© Deep Sea Electronics Plc

All rights reserved. No part of this publication may be reproduced in any material form (including photocopying or storing in any medium by electronic means or other) without the written permission of the copyright holder except in accordance with the provisions of the Copyright, Designs and Patents Act 1988.

Applications for the copyright holder's written permission to reproduce any part of this publication must be addressed to Deep Sea Electronics Plc at the address above.

Any reference to trademarked product names used within this publication is owned by their respective companies.

Deep Sea Electronics Plc reserves the right to change the contents of this document without prior notice.

Amendments Since Last Publication

Amd. No.	Comments
1	First release

Typeface : The typeface used in this document is *Arial*. Care must be taken not to mistake the upper case letter I with the numeral 1. The numeral 1 has a top serif to avoid this confusion.

Table of Contents

1	BIBLIOGRAPHY	4
2	INTERNAL PLC DESCRIPTION	4
2.1	DSE CONTROLLER COMPATIBILITY	5
2.2	FUNCTIONS, FLAGS AND MATHS	6
2.2.1	PLC FUNCTIONS	6
2.2.2	FLAGS	6
2.2.3	PLC MATHEMATICS	6
2.2.3.1	USER REGISTERS	6
2.2.3.2	USER STORES	6
3	ACCESSING THE PLC EDITOR	7
3.1	PLC LOGIC	8
3.1.1	CONDITIONS	9
3.1.1.1	TEST FLAG	9
3.1.1.2	TEST INSTRUMENTATION VALUE	9
3.1.1.3	TEST CALCULATED VALUE	11
3.1.1.4	TEST COUNTER	12
3.1.1.6	TEST TIME AND DATE	12
3.1.1.7	TEST BUTTON PRESS	13
3.1.2	ACTIONS	14
3.1.3	TRIGGER TYPE	14
3.1.3.1	CONTROLLING USER PLC FLAGS	15
3.1.3.2	COUNTER CONTROL	15
3.1.3.3	MATHEMATICAL	16
3.1.3.4	COPY	16
3.1.3.5	CLOCK ADJUST	17
3.1.3.6	TIMER	17
3.1.3.7	FUNCTION	18
3.1.3.8	OVERRIDE GENCOMM	19
3.1.3.9	ALARM RESET	19
3.1.4	TOOLS	20
3.1.4.1	COUNTERS	20
3.1.4.2	TIMERS	20
3.1.4.3	REGISTERS	21
3.1.4.4	STORES	21
3.1.4.5	ADD LABEL	21
3.1.4.6	IMPORT RUNG(S)	22
3.1.4.7	SEARCH FOR USAGE	22
3.1.4.8	MEMORY STATUS	22
4	MODULE DISPLAY	23
5	HOW TO CREATE A PLC PROGRAM	24
5.1	DESIGNING THE PROGRAM	24
5.2	USING THE PLC EDITOR TO MAKE AN EXAMPLE PROGRAM	24
6	TESTING AND DIAGNOSING A PLC PROGRAM	28

1 BIBLIOGRAPHY

This document refers to and is referred to by the following DSE publications, obtained from the DSE website www.deepseapl.com.

DSE Part	Description
057-051	DSE Configuration Suite PC Software Installation & Operation Manual
057-157	DSE335 Configuration Suite PC Software Manual
057-077	DSE7200 and DSE7300 Series Configuration Suite PC Software Manual
057-160	DSE7410 and DSE7420 Configuration Suite PC Software Manual
057-119	DSE8600 Series Configuration Suite PC Software Manual
057-127	DSE8700 Series Configuration Suite PC Software Manual
057-164	DSE8810 Configuration Suite PC Software Manual
057-174	DSE8860 Configuration Suite PC Software Manual
057-203	DSEE800 Configuration Suite PC Software Manual

2 INTERNAL PLC DESCRIPTION

The internal PLC allows the system designer to add functionality to the DSE controller where such functions do not already exist. It also allows the designer to take existing functions within the controller and tailor them to suit the application requirements.

The main point to remember with the PLC is that the designer is not changing existing functions within the DSE controller, rather they are using them in differing ways to help ensure that DSE's high level of protection and safety cannot be bypassed with the PLC. However, great care must still be taken to ensure the PLC program operates as required by the designer.

For example, the DSE8610 controller contains synchronising and load sharing functions, with protections provided by the MultiSet Communications (MSC) link. It would be inappropriate to allow designers to bypass these protections. However to allow customisation, DSE have provided digital input functions to alter the process while maintaining all necessary protections. These input functions are also accessible via *PLC Functions*, described in the section entitled *PLC functions* elsewhere in this document.

 **NOTE: It is the responsibility of the PLC programmer to ensure that the PLC program operates exactly as intended. DSE cannot be held responsible for any issues arising from unintended actions of the PLC program.**

2.1 DSE CONTROLLER COMPATIBILITY

At the time of writing, the following controllers include the internal PLC with the following features:

Feature	DSE335	DSE72xx	DSE73xx	DSE74xx	DSEE800	DSE86xx	DSE87xx	DSE88xx
Number Of Nodes	50	100	100	200	400	400	200	200
Counters	10	10	10	10	20	20	10	10
Timers	10	10	10	10	20	20	10	10
Plc Functions	20	20	20	20	20	20	20	20
User Plc Flags	20	20	20	40	40	40	40	40
Flag Test	✓	✓	✓	✓	✓	✓	✓	✓
Flag Set, Reset, Drive, Toggle	✓	✓	✓	✓	✓	✓	✓	✓
Calendar Test	✓	✓	✓	✓	✓	✓	✓	✓
Instrumentation Test	✓	✓	✓	✓	✓	✓	✓	✓
Button Press Test	✓	✓	✓	✓	✓	✓	✓	✓
Import / Export Rungs	✓	✓	✓	✓	✓	✓	✓	✓
Alarm Reset	✓	✓	✓	✓	✓	✓	✓	✓
Label Space	✗	✗	1024	2048	2048	2048	2048	2048
Editable Timer And Counter Names	✗	✗	✓	✓	✓	✓	✓	✓
PLC SCADA	✓	✗	✗	✓	✓	✓	✓	✓
Override Gencomm	✗	✗	✗	✗	✗	✓	✓	✓
Registers	✗	✗	✗	✗	✗	20	✗	✗
Stores	✗	✗	✗	✗	✗	8	✗	✗
Module Display of Counters & Timers	✗	✗	✗	✗	✗	✓	✗	✗
Module Display of Register & Stores	✗	✗	✗	✗	✗	✓	✗	✗
Front Panel Editing of Counter and Timer Set Points	✗	✗	✗	✗	✗	✓	✗	✗
Front Panel Editing of Registers	✗	✗	✗	✗	✗	✗	✗	✗
Front Panel Editing of Stores	✗	✗	✗	✗	✗	✓	✗	✗
Maths Functions	✗	✗	✗	✗	✗	✓	✗	✗
Clock Adjust (+/- 1hr)	✗	✗	✗	✗	✗	✓	✗	✗

2.2 FUNCTIONS, FLAGS AND MATHS

The PLC operates using key components – *Functions, Flags and Maths*. Almost every PLC program consists of checking Flags and activating Functions or setting user Flags. Additionally more complex programs may include some mathematical operations.

2.2.1 PLC FUNCTIONS

PLC functions can be considered as *Virtual Inputs*. For example, a PLC Function is configured in exactly the same way as a Digital Input. The difference is that the PLC Function is activated by the PLC and does not require hard wiring. In addition it does not ‘use up’ one of the module’s hardware inputs.

2.2.2 FLAGS

Flags can be considered as *Status Items* within the DSE controller. Any operating state or alarm that occurs can be detected by the PLC program. Decisions can then be made as to what action to perform upon particular conditions.

It is also possible to create ‘user flags’ to store the result of a condition or set of conditions. These are known as “PLC Output Flags”.

Module outputs can then be set to operate upon the *PLC Output Flags* or upon the module’s inbuilt *Flags*.

These Flags are often called *Output Sources*.

2.2.3 PLC MATHEMATICS

PLC mathematics allows the user to manipulate instrumentation values with mathematical functions, placing values and results into the module’s *Registers* or *Stores* for access later either by the PLC itself or via the controller’s display.

2.2.3.1 USER REGISTERS

Values placed in the User Registers are lost when the module DC power is removed and after configuration upload from the DSE Configuration Suite PC Software.

User Registers are able to be viewed in the module instrumentation screens after selection using the DSE Configuration Suite PC Software. Refer to the section entitled *Module Display* elsewhere in this document for further details.

2.2.3.2 USER STORES

Values placed in the User Stores are maintained, even when the module DC power is removed. The values are stored in Non-Volatile (N.V.) memory. To minimise the number of writes to the N.V. memory (extending its life), the values are stored at intervals of one minute since the last write to the N.V. memory and then only if the value has changed.

User Stores are able to be viewed and edited in the module instrumentation screens after selection using the DSE Configuration Suite PC Software. Refer to the section entitled *Module Display* elsewhere in this document for further details.

3 ACCESSING THE PLC EDITOR

To access the internal PLC, the DSE Configuration Suite PC Software must be installed and a Configuration from a supported controller must be opened. For details of this refer to DSE Publication 057-051 *DSE Configuration Suite PC Software Installation & Operation Manual* available from www.deepseapl.com.

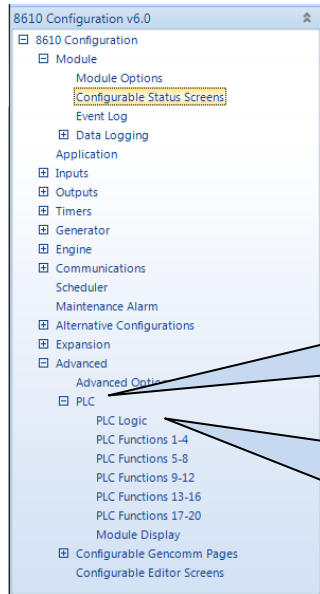

The internal PLC editor is accessed via the *Advanced* section of the configuration in the DSE Configuration Suite PC Software.

The PLC menu consists of the *PLC Logic* page where the main programming takes place, and the configuration of the *PLC Functions* and display of *Registers* and *Stores* on the module's display.

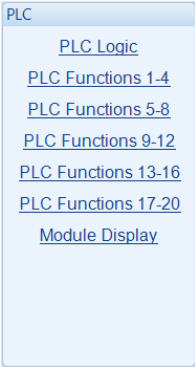

These menu options are described in the following sections.

3.1 PLC LOGIC

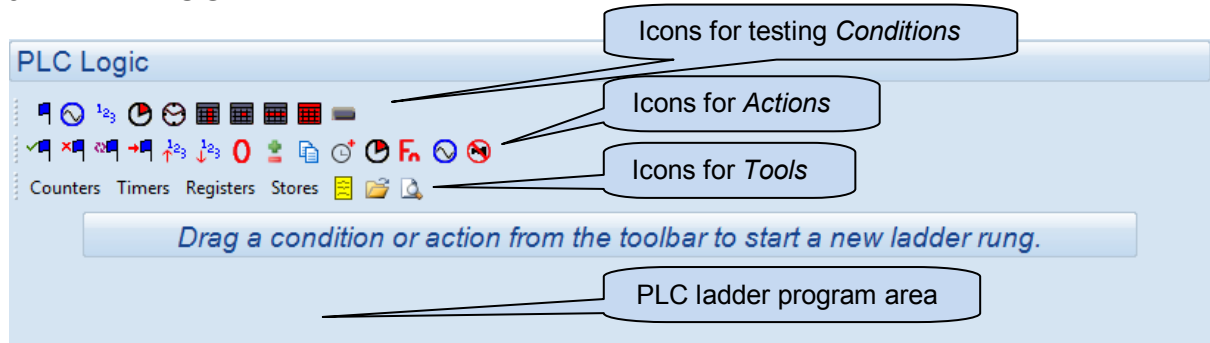

To create a program, click and drag the icons from the *Condition* and *Actions* toolbar onto the program area.

The PLC program is evaluated every 100 ms (10 times per second).

The evaluation time of each rung is indeterminate as each rung consists of a variety of functions, each one with a variable execution time.

Actions are 'queued' by the PLC during the evaluation of the rungs, then executed *in order* at the completion of the program, before the cycle begins again.

This means that the order of the items in the PLC may change the way the program operates.

3.1.1 CONDITIONS

Items on the *Conditions* toolbar allow for a variety of conditions to be tested (checked). Not all items are available with all controllers.

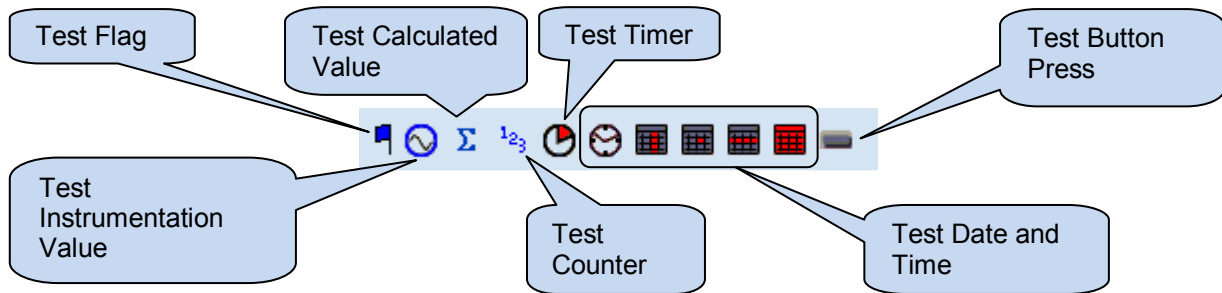

3.1.1.1 TEST FLAG

A *Flag* is an internal state of the controller. Some examples of flags include operating mode and current alarm conditions. The list of testable flags varies depending upon the controller being configured and is the same list for configuring the module's output relays. A full list along with descriptions is contained within the relevant DSE Configuration Suite PC Software Manual.

3.1.1.2 TEST INSTRUMENTATION VALUE

Allows the controller's instrumentation to be tested in a number of ways.

Selection	Mathematical Symbol
Less than	< (Or Value is Under Range)
At most	<= (Or Value is Under Range)
Equal to	=
At least	>= (Or Value is Over Range or at another Sentinel Value)
More than	> (Or Value is Over Range or at another Sentinel Value)
Between	>= AND <= (And Value is not at a Sentinel Value)

The list of testable flags varies depending upon the controller. A full list of module instrumentation is contained within the relevant Operator Manual.

Not all instrumentation can be read from all controllers. These include :

- Instruments that are not supported by the controller. For example "Mains Voltage" is only available in controllers with Mains Sensing.
- Instruments not configured in the controller. For example the *Fuel Level Input* may be configured to be "not used".
- Instruments that are under range or over range. For example if the *Coolant Temperature* is below the measurable range of the temperature sensor being used.
- Instruments that are in a fault condition. For example the *Oil Pressure Sensor* may be "open circuit".
- Instruments whose condition cannot be determined. For example *Power Factor* is not measurable when there is no load applied to the generator.

In these circumstances the module returns a *sentinel* value as listed overleaf. The actual value returned for a given state varies depending upon the size and type of instrument being read.

NOTE: It is the responsibility of the PLC programmer to ensure that the PLC program operates exactly as intended. DSE cannot be held responsible for any issues arising from unintended actions of the PLC program.

Sentinel Values for Instrumentation

Size of register	Sentinel Values (Hexadecimal)	Sentinel Values (Decimal)	Description
16 bit unsigned, any scale	0xFFFF	65535	Unimplemented
	0xFFFE	65534	Over measurable range
	0xFFFD	65533	Under measurable range
	0xFFFC	65532	Transducer fault
	0xFFFB	65531	Bad data
	0xFFFA	65530	High digital input
	0xFFFF9	65529	Low digital input
	0xFFFF8	65528	Reserved
16 bit signed, any scale	0x7FFF	32767	Unimplemented
	0xFFFE	32766	Over measurable range
	0xFFFD	32765	Under measurable range
	0xFFFC	32764	Transducer fault
	0xFFFB	32756	Bad data
	0xFFFA	32763	High digital input
	0xFF9	32762	Low digital input
	0xFF8	32761	Reserved
32 bit unsigned, any scale	0xFFFFFFFF	4294967295	Unimplemented
	0xFFFFFFFFE	4294967294	Over measurable range
	0xFFFFFFFFD	4294967293	Under measurable range
	0xFFFFFFFFC	4294967292	Transducer fault
	0xFFFFFFFFB	4294967291	Bad data
	0xFFFFFFFFA	4294967290	High digital input
	0xFFFFFFFF9	4294967289	Low digital input
	0xFFFFFFFF8	4294967288	Reserved
32 bit signed, any scale	0x7FFFFFFF	2147483647	Unimplemented
	0xFFFFFFFFE	2147483646	Over measurable range
	0xFFFFFFFFD	2147483645	Under measurable range
	0xFFFFFFFFC	2147483644	Transducer fault
	0xFFFFFFFFB	2147483643	Bad data
	0xFFFFFFFFA	2147483642	High digital input
	0xFFFFFFFF9	2147483641	Low digital input
	0xFFFFFFFF8	2147483640	Reserved

3.1.1.3 TEST CALCULATED VALUE

 **NOTE:** On some controllers, *Calculated Values* are available in the *Test Instrumentation* section.

Calculated values are predefined by DSE and are included to provide additional ways of testing of the controller's instrumentation.

Selection	Description
Average	An average of the instrumentation
Difference	The difference between the maximum and the minimum
Maximum	The highest instrumentation value
Minimum	The lowest instrumentation value
Minimum Index	Indicates the lowest of the three phases (L1=1, L2=2, L3=3)
Maximum Index	Indicates the highest of the three phases (L1=1, L2=2, L3=3)

Example:

L1 = 230 V AC
 L2 = 233 V AC
 L3 = 224 V AC

Results of the *Calculated Values* operators are as follows:

Average	Difference	Maximum	Minimum	Minimum Index	Maximum Index
229 ((230+233+224)/3)	9 (233-224)	233 Maximum Value	224 Minimum Value	3 L3 is the minimum of the three phases	2 L2 is the maximum of the three phases

3.1.1.4 TEST COUNTER

Allows a counter to be tested to see if it has reached the configurable limit.

State	Value When Tested
Not Active	False
Active, not reached limit	False
Active, reached or past limit	True





3.1.1.5 TEST TIMER

Allows a timer to be tested to see if it has reached the configurable limit.

State	Value When Tested
Not Active	False
Active, not reached limit	False
Active, reached or past limit	True



3.1.1.6 TEST TIME AND DATE

Test *Time and Date* are a collection of tests that allows an action based upon a specific time, date or time and date.

Icon	Name	Description
	Time of Day	Allows testing for a specific time ie 10:32 am
	Day of Week	Allows testing for a specific day(s) ie Tuesday
	Day of Month	Allows testing for a specific date(s) in the month ie 25 th
	Week in Month	Allows testing for a specific week(s) in the month ie Week 3
	Month	Allows testing to a specific month(s) ie September

It is also possible to combine two or more of these tests to make a more specific test.

For example:

 +  +  allows a test for a specific time, day and month, for instance 10:32am on any Tuesday in September.

3.1.1.7 TEST BUTTON PRESS

Allows the PLC program to check if any of the control buttons are being pressed on the controller.

Depending upon controller type this allows testing for the following button presses:

DSEgenset Range	DSEATS Range
Stop/Reset	Start Inhibit
Manual	Manual
Auto	Auto
Test	Mode
Start	Mute
Mains	Information
Gen	S1
Mute	S2

Example: Testing for multiple button presses.

This example drives *PLC Flag 1* when the *Test* button OR *Start* button is pressed:

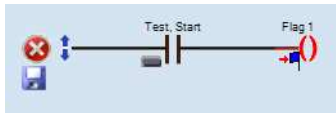

This example drives *PLC Flag 1* when the *Test* button AND *Start* button is pressed:



3.1.2 ACTIONS

The action toolbar contains the icons that allow the PLC to perform certain actions. These are described in the following sections.

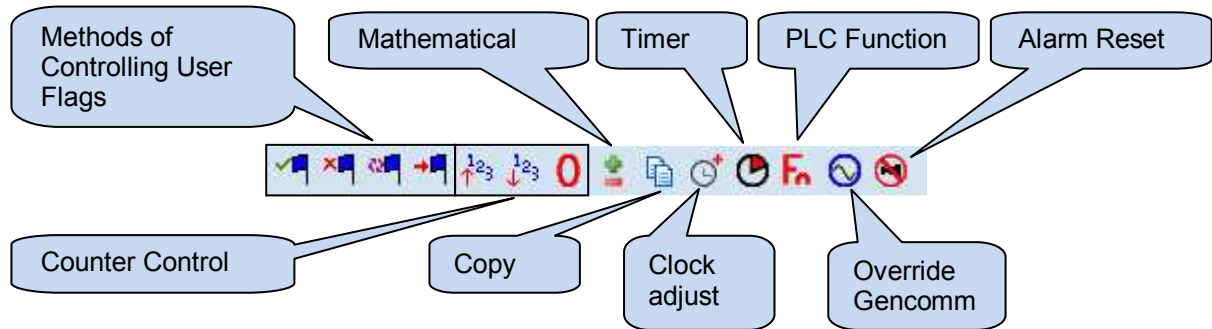

3.1.3 TRIGGER TYPE





Some *Actions* are 'edge triggered'. This means the action takes place when the preceding *Condition(s)* change. If a *Condition* remains unchanged, the *Action* is not repeated.

Some *Actions* are 'level triggered'. This means the action takes place if the *Condition(s)* are true and continues to be actioned until the *Condition(s)* become false.

Action Type	Trigger Type
Set Flag	Edge
Drive Flag	Edge
Reset Flag	Edge
Toggle Flag	Edge
Increment Counter	Edge
Decrement Counter	Edge
Zero Counter	Edge
Mathematical	Level
Copy	Level
Clock Adjust	Edge
Timer	Level
Plc Function	Level
Gencomm Override	Level
Alarm Reset	Level



3.1.3.1 CONTROLLING USER PLC FLAGS

Four different ways of controlling the User Settable PLC Flags are possible.

Icon	Name	Description
	Set Flag	Sets a Flag. The flag remains set until another a <i>Reset</i> or <i>Toggle</i> action changes it. Removal of the condition that activated the Set command has no effect on the state of a flag. This is useful for 'remembering' that a condition has occurred.
	Reset Flag	If a flag is in a Set position, this action resets the flag.
	Toggle Flag	Changes the state of a flag. If the flag is currently set, it resets it. If the flag is currently reset, it sets it.
	Drive Flag	This action makes the flag state follow the condition that precedes it. For example if the condition is true, the flag is set. If the condition is subsequently removed, the flag is automatically reset.

3.1.3.2 COUNTER CONTROL

Actions to control user counters.

Icon	Name	Description
	Increment counter	Adds one to the specified counter until the counter reaches its configured <i>counter limit</i> .
	Decrement counter	Subtracts one from the specified counter (unless the counter is already zero (0)).
	Zero counter	Sets the specified counter to Zero.

3.1.3.3 MATHEMATICAL

Actions to allow mathematical functions to be performed and the results placed in a Register or Store.

Item	Description
Operation Value 1 Value 2	<p>Addition: $Value1 + Value 2$ Subtraction: $Value 1 - Value 2$ Multiply: $Value 1 * Value 2$ Divide: $Value 1 / Value 2$ (remainder is lost) Remainder: The remainder of $Value 1 / Value 2$ Magnitude: The value with its 'sign' removed. For example both 6 and -6 give a value of 6. Minimum: The lowest of $Value 1$ and $Value 2$. For example $Value 1 = 5$, $Value 2 = 7$. The <i>Minimum</i> is 5. Maximum: The highest of $Value 1$ and $Value 2$. For example $Value 1=5$, $Value 2 = 7$. The <i>Maximum</i> is 7.</p>
Target	<p>The location where the result of the mathematical operation is to be placed.</p> <p>Register: Values placed in the User Registers are lost when the module DC power is removed. Store: Values placed in the User Stores are maintained, even when the module DC power is removed.</p> <p>For further details of Registers and Stores, see the section entitled <i>PLC Maths</i> elsewhere in this document.</p>

3.1.3.4 COPY

Allows a value to be copied or placed into a Register or Store.

Item	Description
Value	<p>Fixed Value: Enter the value manually. Calculated Value: Select the calculated instrumentation value from a list of predefined options. Instrumentation Value: Select one of the modules instrumentation items. Register: Select one of the <i>Registers</i>. Store: Select one of the <i>Stores</i>.</p>
Target	<p>The location where the Value is to be placed.</p> <p>Register: Values placed in the <i>Registers</i> are lost when the module DC power is removed. Store: Values placed in the <i>Stores</i> are maintained, even when the module DC power is removed.</p> <p>For further details of <i>Registers</i> and <i>Stores</i>, see the section entitled <i>PLC Maths</i> elsewhere in this document.</p>

3.1.3.5 CLOCK ADJUST

Included to ease Daylight Saving adjustments, this allows one hour to be added to or subtracted from the module's internal clock.

Example:

Showing the addition of one hour on the fourth Sunday in March at 1 am. Additionally this is setting a User Store to the value of 1. This allows us to check in the PLC SCADA or in the module instrumentation if DST is active:

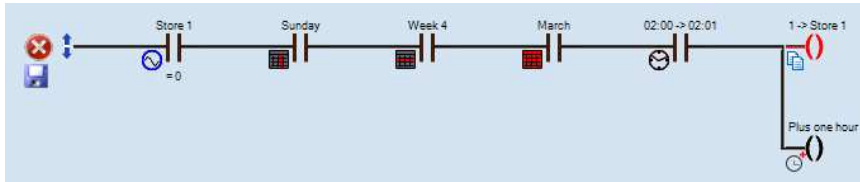

Example:

Showing the subtraction of one hour on the fourth Sunday in October at 2 am. We additionally check the status of DST (*Store 1*) to ensure the clock is not continually adjusted one hour later!

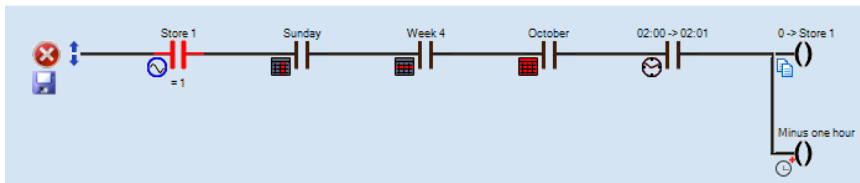

3.1.3.6 TIMER

Allows a timer to be started.

When the condition leading to the timer becomes true, the timer is started and runs until the configurable timer limit is reached. If the condition becomes false, the timer is stopped and the current time is 'lost'. The timer begins from zero if it is restarted.

If it is required to restart a timer, it's condition must be made false, then true again in order to re-enable the timer. This restarts the timer from zero.

3.1.3.7 FUNCTION

PLC functions can be considered as *Virtual Inputs*. For example a PLC Function is configured in exactly the same way and has the same selections as a Module Digital Input. The difference is that the PLC Function is activated by the PLC and does not require hard wiring.

Item	Description
Function	User Configured: Allows the user to configure the <i>Function</i> to perform an alarm or status indication. Digital Input Selection List: Allows the user to select from a predefined selection list. Refer to the DSE Configuration Suite PC Software Manual for the host controller in use for a full description of possible selections.
Polarity	Close to Activate: The Function is 'normally inactive' and must be driven in the PLC in order to activate it. Open to Activate: The Function is 'normally active' and must driven in the PLC in order to de-activate it.
Action (Only applicable when function is set to "User Configured")	Electrical Trip: When activated, an electrical trip alarm is generated, the load switch is opened (if closed) and the generator placed into the cooling run before stopping. Indication: No alarm condition is generated and the set continues to run. This is often used to create status indications or be monitored by the user's PLC logic. Warning: When activated, a warning alarm is generated but the set remains running. Shutdown: When activated, a shutdown alarm is generated, the load switch (if closed) is immediately opened and the set is immediately stopped.

Example using a function to prevent starting the generator upon a mains failure during the whole of Sunday. This uses PLC Function 1, configured to "Auto Start Inhibit".

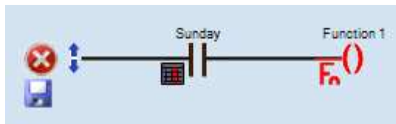

The screenshot shows the configuration window for 'Function 1'. The settings are as follows:

- Function: Auto Start Inhibit (selected in a dropdown menu)
- Polarity: Close to Activate (selected in a dropdown menu)
- Action: (empty dropdown menu)
- Arming: (empty dropdown menu)
- LCD Display: (empty text field)
- Activation Delay: 0s (with a slider control)

3.1.3.8 OVERRIDE GENCOMM

Using an external PLC that has a Modbus master serial port, it is possible to write values to the DSE controllers to change certain parameters. The protocol used for this is called Gencomm.

Using the DSE internal PLC, it is possible to change these same values using the *Override Gencomm* action.

Depending upon controller type, the parameters that can be changed vary. Some controllers have no adjustable parameters using this function.

Example 1: Using Override Gencomm, the *Run Priority* of the set can be changed.

Example 2: Using Override Gencomm, the amount of power the generator is producing can be changed.

3.1.3.9 ALARM RESET

This action allows individual alarms to be reset. An alarm can only be reset if the condition that generated the alarm is no longer present.

To perform an action that resets ALL alarms, it's more appropriate to drive a PLC Function that has been configured to *Alarm Reset*.

3.1.4 TOOLS

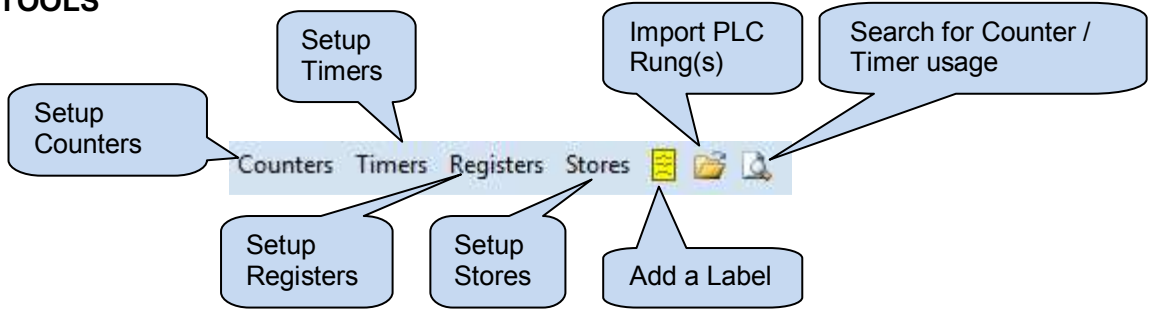

3.1.4.1 COUNTERS

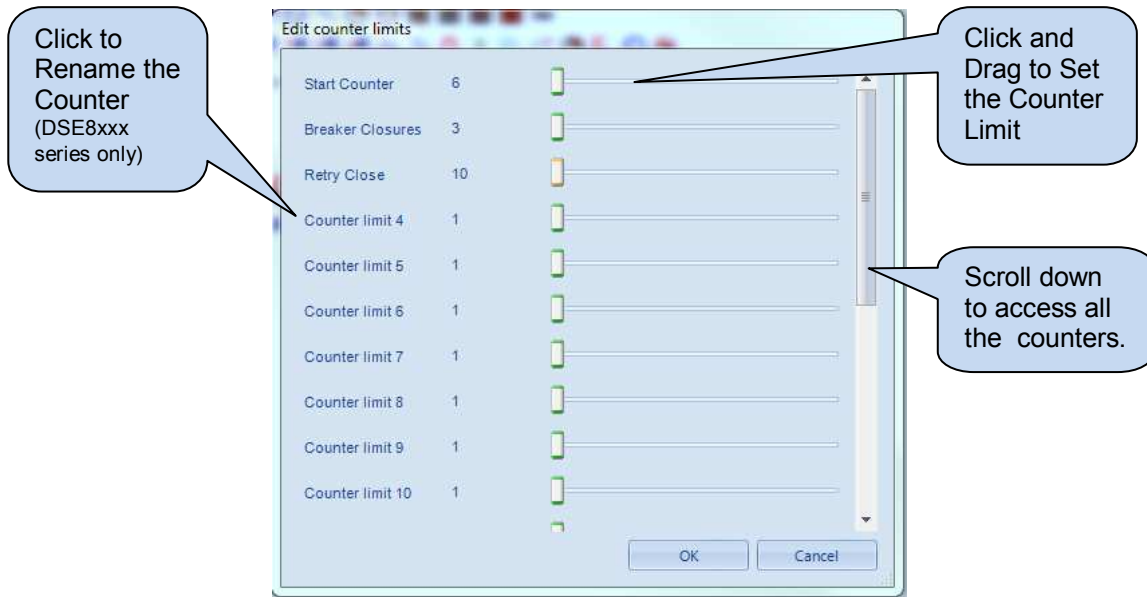

3.1.4.2 TIMERS

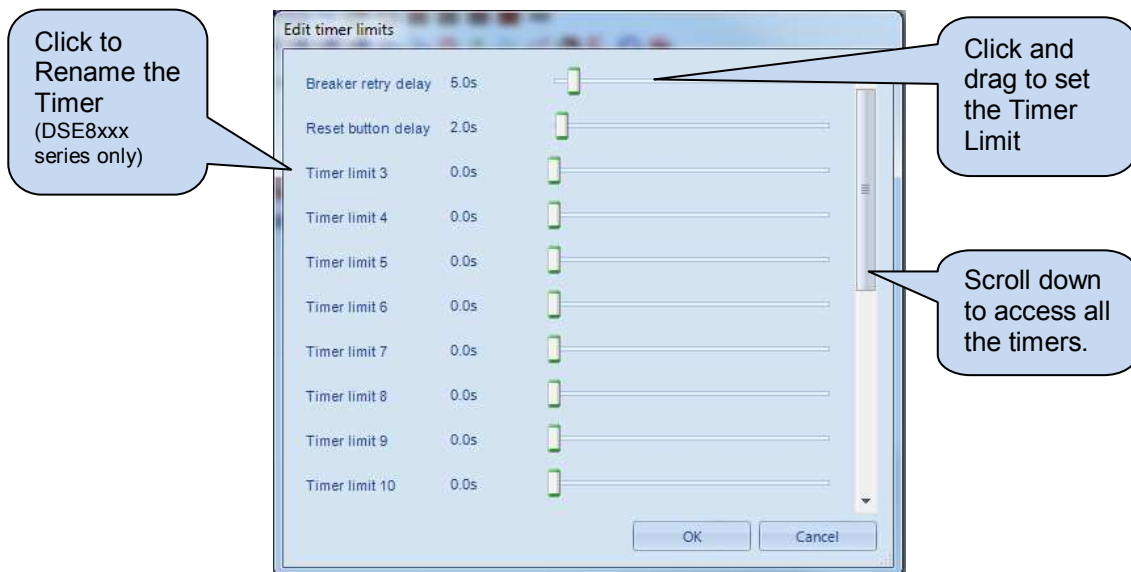

3.1.4.3 REGISTERS

Allows the user registers to be named for easier referencing and display on the module screen.

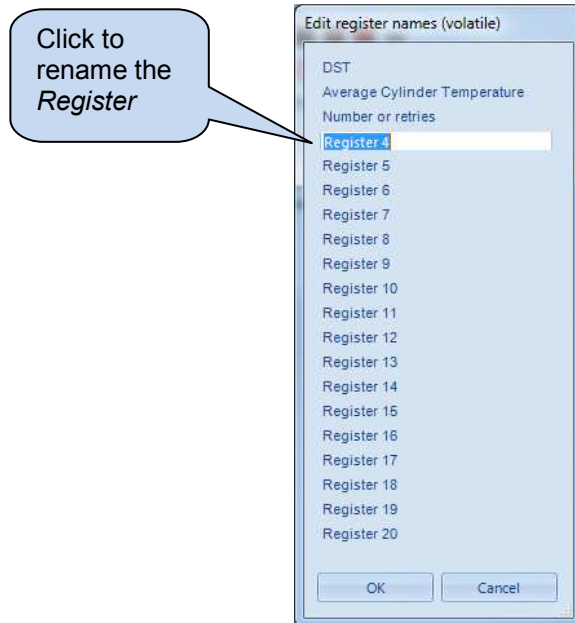

3.1.4.4 STORES

Allows the user registers to be named for easier referencing and display on the module screen.

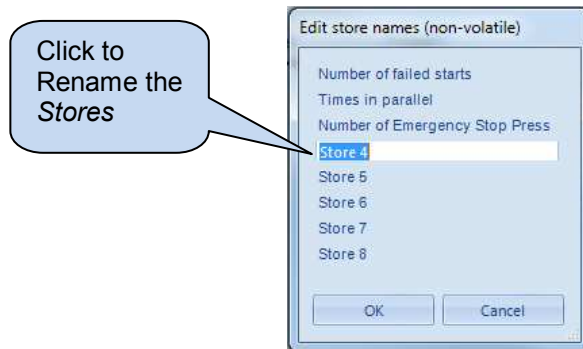

3.1.4.5 ADD LABEL

Clicking *Add Label* generates a blank label in the PLC Ladder. This allows the designer to place notes in the PLC Ladder.

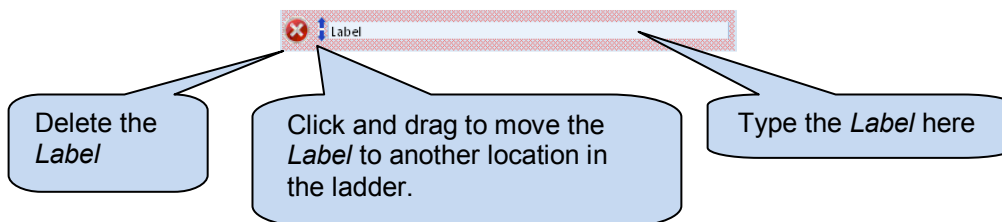

3.1.4.6 IMPORT RUNG(S)

Allows the designer to import a PLC program containing one or more rungs into the current program. This is useful for reusing functions created in other configurations.

Care must be taken when using this function as *Flags*, *Registers*, *Stores*, *Counters*, *Timers* and *PLC Functions* may be called that are already in use in the current program.

3.1.4.7 SEARCH FOR USAGE

Shows a list of currently used *Functions*, *Counters*, *Timers*, *Registers* and *Stores*. This makes it easier when adding additional counters and timers by allowing the designer to see which ones are already in use.

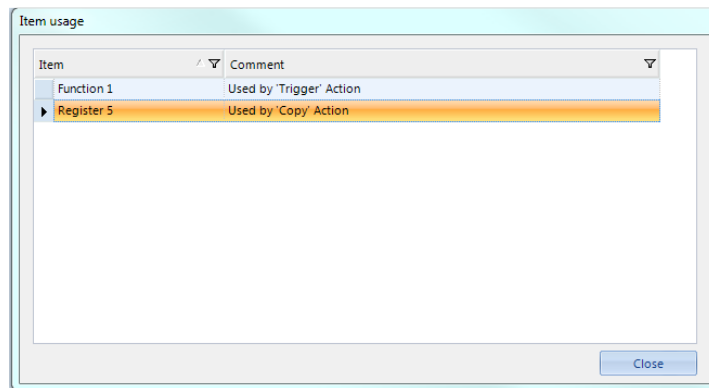

3.1.4.8 MEMORY STATUS

The PLC memory status is contained at the bottom of the *PLC Logic* page. The amount of available memory differs between controller ranges.

Blocks used	0 / 400	Labels used	8 / 2048
-------------	---------	-------------	----------

The amount of memory blocks used in the ladder program.

The amount of labels used by *Counters*, *Timers*, *Registers*, *Stores* and user placed *Labels*.

4 MODULE DISPLAY

NOTE: This section is not available on all controllers. See the section entitled *DSE Controller Compatibility* elsewhere in this document.

This section allows the user to select up to eight items from the complete list of *Counters*, *Timers*, *Registers* or *Stores* for display on the host module's instrumentation display.

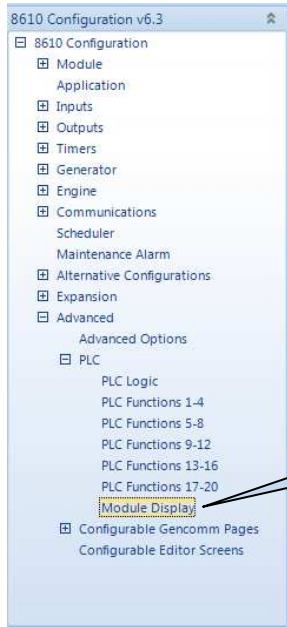

The *Module Display* page is located under *Advanced | PLC* in the module Configuration.

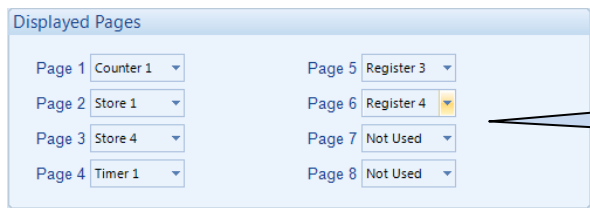

Select which of the *Counters*, *Timers*, *Registers* and *Stores* are to be show on the controller's display.

After selection for display on the host controller, *Counters*, *Timers*, *Registers* and *Stores* are able to be viewed and/or edited as below on the controller display.

Parameter	View	Edit
<i>Counter Value</i>	✔	✘
<i>Counter Limit</i>	✔	✔
<i>Timer Value</i>	✔	✘
<i>Timer Limit</i>	✔	✔
<i>Register</i>	✔	✘
<i>Store</i>	✔	✔

NOTE: All *Stores* are able to be edited in the *SCADA | PLC | PLC Stores* section of the *DSE Configuration Suite PC Software* regardless of their selection in the *Module Display | Displayed Pages* section of the configuration. For details of this, refer to the relevant control *DSE Configuration Suite PC Software Manual* as listed in the *Bibliography* section of this manual.

5 HOW TO CREATE A PLC PROGRAM

5.1 DESIGNING THE PROGRAM

The fundamental issue in creating a PLC program is knowing exactly what is required! It is usually best to start with a written description. As the DSE PLC is based around the internal system of inputs and outputs, keep these functions in mind when designing the solution.

5.2 USING THE PLC EDITOR TO MAKE AN EXAMPLE PROGRAM

For example, if a function is required to silence the controller's alarm 30 seconds after it begins, the designer must consider how to determine if the alarm is active and then how to perform the silencing function.

Looking through the list of *Flags* we find *Audible Alarm*. This flag is set whenever the controller's internal audible alarm is active.

Therefore, in the *PLC Logic* screen we can 'drag' the  (Flag Test) icon to the Program Area. The following options box appears:

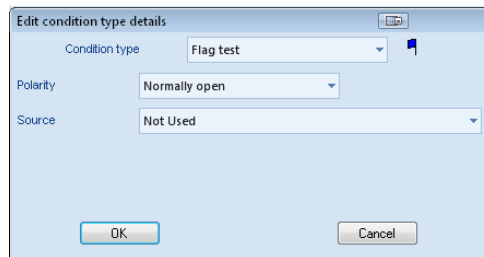

Parameter	Description
Condition Type	The type of condition to check for. This is automatically set when the icon is dragged from the Condition toolbar but can be changed if the wrong one is inadvertently selected.
Polarity	Normally Open: Tests if the condition is True. Normally Closed: Tests if the condition is False.
Source	Contains the list of available Flags. This list differs between controller types. A full list of sources is included in the relevant controller's Configuration Suite manual.
OK	Click to add the condition to the PLC program.
Cancel	Click to cancel and return to the editor without adding the condition.

In our example we select *Flag Test*, *Normally Open*, *Audible Alarm* and click .

Our example program is now as below. If it isn't, then go back and check what went wrong.



Designing the PLC Program

The next thing we need to do is set a timer that expires in 30 seconds after the audible alarm begins.

Drag the  (Delay) icon from the *Action Toolbar* and drop it just to the right of the black line to the right of the *Audible Alarm* symbol that has just been placed.

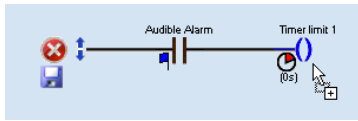

As the mouse button is released, the following settings box appears :

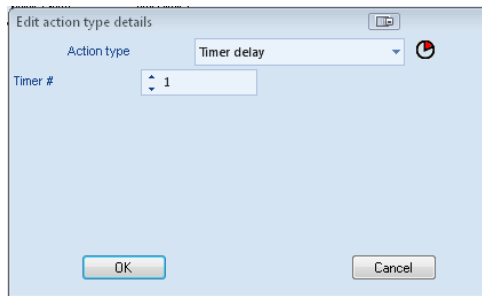

Parameter	Description
Action Type	The type of action to perform. This is automatically set when the icon is dragged from the Action toolbar but can be changed if the wrong one is inadvertently selected.
Timer #	The number of the timer to be operated.

Next click , the *Timer Limit* settings box appears.

For our example, set *Timer limit 1* to 30s: and click .



Now the program looks like this:



This program now checks for an audible alarm and start a timer that runs for 30 seconds (so long as the audible alarm remains active). Next we need to configure what happens when the timer expires.

We need a new *Condition*:  (Timer Test). Drag this from the *Condition Toolbar* into the empty space below the first PLC rung. The details window appears. Make selections as shown below. This checks to see if *Timer # 1* has expired.

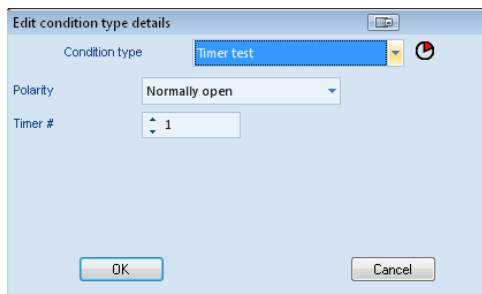

Our program is now as shown below:

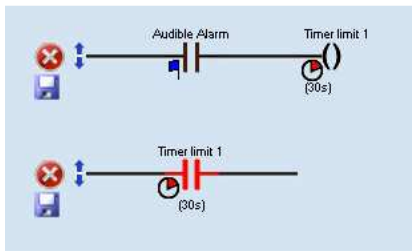

We have now just one more item to add to the PLC Ladder.

When the 30 second timer expires, we want it to silence the audible alarm. This is achieved using a *PLC Function*. Drag the (Trigger Function) icon and drop it to the right of the *Timer Limit 1* condition.

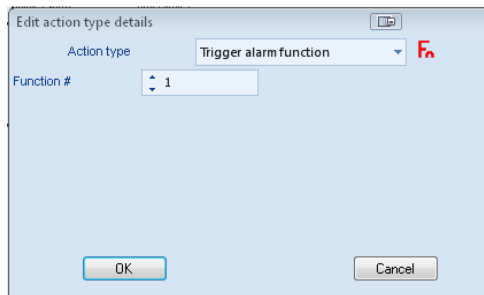

Parameter	Description
Action Type	The type of action to perform. This is automatically set when the icon is dragged from the Action toolbar but can be changed if the wrong one is inadvertently selected.
Function #	The number of the Function to be operated.

For our example, select *Function # 1*.

Our program is now as shown below:

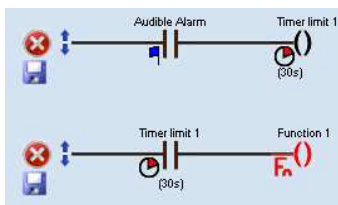

This program now checks for an audible alarm and start a timer that runs for 30 seconds (so long as the audible alarm remains active).

When the timer expires, Function 1 is triggered.

Finally we have to configure what Function 1 is used for.

Select *PLC Functions 1-4* from the Configuration Editor:

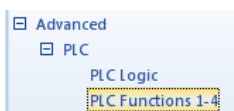

Designing the PLC Program

The PLC Functions editor is displayed.
PLC Functions have exactly the same choices as module digital inputs.

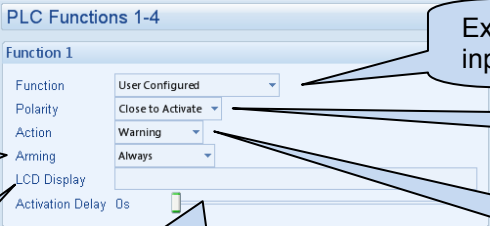

The screenshot shows the 'PLC Functions 1-4' editor with 'Function 1' selected. The configuration options are:

- Function: User Configured
- Polarity: Close to Activate
- Action: Warning
- Arming: Always
- LCD Display: (empty)
- Activation Delay: 0s

Callouts explain the options:

- Configures when the input is active: Never, always, active from starting, active from the end of the safety timer.** (points to Arming)
- This is the text that is displayed on the module screen when the alarm is triggered.** (points to LCD Display)
- Click and drag to change the setting. This is used to give a delay on acceptance of the input. Useful for liquid level switches or to mask short term operations of the external switch device.** (points to Activation Delay)
- Example of a user configured input.** (points to Function)
- Close or open to activate.** (points to Polarity)
- Select the type of alarm required.** (points to Action)

For our example PLC program, we need to select *Alarm Mute*, a predefined function that silences the alarm:

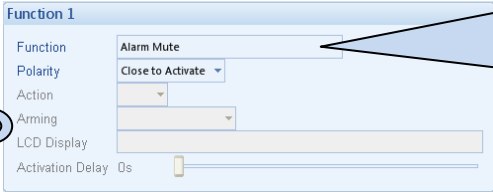

The screenshot shows 'Function 1' with the 'Alarm Mute' function selected. The configuration options are:

- Function: Alarm Mute
- Polarity: Close to Activate
- Action: (greyed out)
- Arming: (greyed out)
- LCD Display: (greyed out)
- Activation Delay: 0s

Callouts explain the state of the options:

- As this example shows a predefined function, these parameters are greyed out as they are not applicable** (points to Action, Arming, LCD Display)
- Function. The possible selections differ with each controller range. These are listed in the relevant Configuration Suite Software manual.** (points to Function)

Finally. We have a program that now checks for an audible alarm and starts a timer that runs for 30 seconds (so long as the audible alarm remains active).
When the timer expires, Alarm Mute (Function 1) is triggered silencing the alarm. If another alarm occurs, the audible alarm restarts, starting our 30 second timer again.

Remember to click  (Save) to save a copy of the configuration file. The PLC program is contained within the configuration file.

Also remember to click  (Write to module) to upload the configuration file to the connected controller.

6 TESTING AND DIAGNOSING A PLC PROGRAM

Many PLC programs are very simple, having only one or two rungs (lines) in the ladder. Often, the easiest way to test these is to simply use the module and test that the actions are as required. However sometimes this leads to us finding that the PLC program is not acting as required. This is usually caused by an error in the design of the program.

DSE have provided a diagnostic monitor in the SCADA section of the Configuration Suite Software to aid the fault finding process. This is not available in all controllers with PLC functionality.

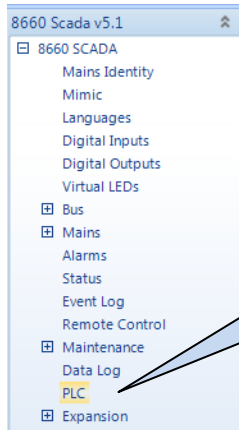

Select *PLC* in the SCADA section of the Config Suite when connected to the module containing the PLC ladder to be viewed / diagnosed. The message:

Fetching PLC configuration from module...

is shown until the entire PLC ladder has been downloaded for viewing from the connected controller.

Conditions highlighted in green show ACTIVE (true) conditions. *Conditions* with no highlight are INACTIVE (false) 'Clear' means that the flag is not set. 'Set' means that the flag is set. See below for further details.

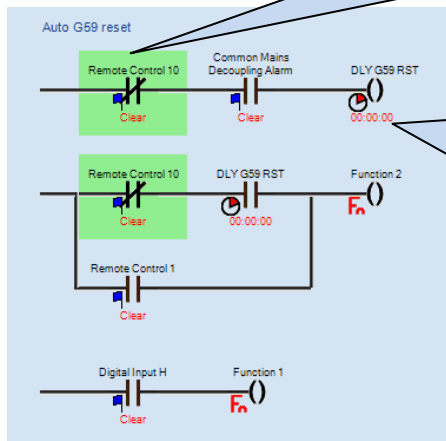

Timers and Counter shows their current value.

Note that depending upon update time of the SCADA screen, this may not be in 'real time'. Fast connection methods such as USB or direct Ethernet connection (no internet) give much quicker update rates.

Example showing SCADA display of Flag Testing:

PLC Editor Symbol	Description	PLC SCADA symbol when PLC Output Flag 1 is	
		Active (True)	Inactive (False)
	Test PLC flag 1 (normally open)		
	Test PLC flag 1 (normally closed)		

This Page is Intentionally Blank

This Page is Intentionally Blank