



DEEP SEA ELECTRONICS

DSE BC2410Ei Operator Manual

Document Number: 057-316

Author: David O'Connor





Deep Sea Electronics Ltd.

Highfield House
Hunmanby
North Yorkshire
YO14 0PH
England

Sales Tel: +44 (0) 1723 890099

E-mail: sales@deepseaelectronics.com

Website: www.deepseaelectronics.com

DSE BC2410Ei Operator Manual

© Deep Sea Electronics Ltd.

All rights reserved. No part of this publication may be reproduced in any material form (including photocopying or storing in any medium by electronic means or other) without the written permission of the copyright holder except in accordance with the provisions of the Copyright, Designs and Patents Act 1988.

Applications for the copyright holder's written permission to reproduce any part of this publication must be addressed to Deep Sea Electronics Ltd. at the address above.

The DSE logo and the names DSEGenSet®, DSEATS®, DSEPower® and DSEControl® are UK registered trademarks of Deep Sea Electronics Ltd.

Any reference to trademarked product names used within this publication is owned by their respective companies.

Deep Sea Electronics Ltd. reserves the right to change the contents of this document without prior notice.

Amendments Since Last Publication

Issue No.	Comments
1	Initial Release
2	Update to images and add product weights
3	Terminology updated from Master/Slave to Client/Server

Typeface: The typeface used in this document is *Arial*. Care must be taken not to mistake the upper-case letter I with the numeral 1. The numeral 1 has a top serif to avoid this confusion.

TABLE OF CONTENTS

SECTION	PAGE
1 INTRODUCTION.....	5
1.1 CLARIFICATION OF NOTATION.....	5
1.2 GLOSSARY OF TERMS.....	5
1.3 BIBLIOGRAPHY.....	6
1.3.1 INSTALLATION INSTRUCTIONS.....	6
1.3.2 MANUALS.....	6
1.3.3 TRAINING GUIDES.....	6
2 SPECIFICATION.....	7
2.1 PART NUMBERING.....	7
2.2 OPERATING TEMPERATURE.....	7
2.3 REQUIREMENTS FOR UL CERTIFICATION.....	8
2.4 TERMINAL SPECIFICATION.....	8
2.5 AC SUPPLY.....	9
2.5.1 EFFICIENCY CURVES.....	10
2.6 DC OUTPUT.....	11
2.6.1 OUTPUT DE-RATE CURVES.....	12
2.7 INPUTS.....	13
2.7.1 DIGITAL INPUT.....	13
2.7.2 TEMPERATURE SENSOR.....	13
2.8 CHARGE FAIL OUTPUT RELAY.....	13
2.9 COMMUNICATION PORTS.....	13
2.10 COMMUNICATION PORT USAGE.....	14
2.10.1 USB DEVICE PORT (PC CONFIGURATION).....	14
2.10.2 COMMUNICATION PORT.....	15
2.10.2.1 CABLE SPECIFICATION.....	15
2.10.2.2 CONFIGURED AS A DSENET PORT.....	15
2.10.2.3 CONFIGURED AS AN RS485 PORT.....	16
2.10.2.3.1 REMOTE DISPLAY.....	16
2.10.2.3.2 MODBUS SERVER.....	16
2.11 DIMENSIONS AND MOUNTING.....	18
2.12 APPLICABLE STANDARDS.....	19
2.12.1 ENCLOSURE CLASSIFICATIONS.....	20
2.12.1.1 IP CLASSIFICATIONS.....	20
2.12.1.2 NEMA CLASSIFICATIONS.....	20
3 INSTALLATION.....	21
3.1 BATTERY SUITABILITY.....	21
3.2 USER CONNECTIONS.....	22
3.2.1 CONNECTION ACCESS.....	22
3.2.2 CONNECTION DESCRIPTIONS.....	23
3.2.2.1 CONNECTOR A.....	23
3.2.2.2 CONNECTOR B / C.....	24
3.2.2.3 CONNECTOR D.....	24
3.2.2.4 USB DEVICE (PC CONFIGURATION) CONNECTOR.....	25
3.2.2.5 CABLE ENTRY.....	26
3.3 TYPICAL WIRING DIAGRAM.....	27
3.3.1 EARTH SYSTEMS.....	27
3.3.1.1 NEGATIVE EARTH.....	27
3.3.1.2 POSITIVE EARTH.....	27
3.3.1.3 FLOATING EARTH.....	27
4 DESCRIPTION OF CONTROLS.....	28
4.1 CONTROL PUSH BUTTONS.....	29
4.2 VIEWING THE INSTRUMENT PAGES.....	29
4.2.1 HOME SCREEN.....	29
4.2.2 INSTRUMENTATION SCREENS.....	30

4.2.2.1	BATTERY CHARGER OUTPUT	32
4.2.2.2	BATTERY	32
4.2.2.3	AC SUPPLY	33
4.2.2.4	BATTERY CHARGER INFORMATION	33
4.2.2.5	BATTERY CHARGER OPERATING MODE	33
4.2.2.6	BATTERY CHARGER ACTIVE ALARMS	34
4.2.2.6.1	WARNING ALARMS	35
4.2.2.6.2	SHUTDOWN ALARMS	36
4.2.3	ENGINEERING PAGES	37
4.2.3.1	ENGINEERING PAGE 1	37
4.2.3.2	ENGINEERING PAGE 2	38
4.2.3.2.1	DISPLAY ABBREVIATIONS	38
5	OPERATION	39
5.1	CHARGE FAIL RELAY	39
5.2	DIGITAL INPUT	39
5.3	PSU MODE	39
5.4	CHARGING MODE	40
5.4.1	CHARGING PROFILE	41
5.4.2	MANUAL BOOST OPERATION	43
5.4.3	TEMPERATURE COMPENSATION	44
6	PROTECTIONS	45
6.1	WARNING ALARMS	45
6.2	SHUTDOWN ALARMS	46
7	FRONT PANEL EDITOR	47
7.1	ACCESSING THE FRONT PANEL EDITOR	47
7.1.1	SELECTING A PARAMETER	47
7.1.2	EDITING A PARAMETER	47
7.1.3	EXITING THE EDITOR	47
7.2	FRONT PANEL EDITOR PARAMETERS	48
8	MODBUS	49
8.1	READING VALUES	49
8.2	WRITING VALUES	50
8.2.1	TOGGLE BOOST MODE	50
8.2.2	TOGGLE CHARGER ON/OFF	50
9	FAULT DIAGNOSIS	51
10	EFFICIENCY CALCULATIONS	52
10.1	MAXIMUM POWER DISSIPATION	52
10.2	MAXIMUM POWER CONSUMPTION	52
10.3	POWER FACTOR AT MAXIMUM POWER	52
11	MAINTENANCE, SPARES, REPAIR AND SERVICING	53
12	WARRANTY	53
13	DISPOSAL	53
13.1	WEEE (WASTE ELECTRICAL AND ELECTRONIC EQUIPMENT)	53

1 INTRODUCTION

This document details the installation and operation requirements of the DSE BC2410Ei enclosed battery charger and is part of the DSE Power® range of products.



The manual forms part of the product and should be kept for the entire life of the product. If the product is passed or supplied to another party, ensure that this document is passed to them for reference purposes.

This is not a *controlled document*. DSE do not automatically inform on updates. Any future updates of this document are included on the DSE website at www.deepseaelectronics.com

The DSE BC2410Ei is designed to fulfil the most common functions required of a charger in the generating set industry. Combining a range of display options, protected outputs, intelligent charging and power supply operation within a robust enclosure.

1.1 CLARIFICATION OF NOTATION

Clarification of notation used within this publication.

	NOTE:	Highlights an essential element of a procedure to ensure correctness.
	CAUTION!	Indicates a procedure or practice, which, if not strictly observed, could result in damage or destruction of equipment.
	WARNING!	Indicates a procedure or practice, which could result in injury to personnel or loss of life if not followed correctly.

1.2 GLOSSARY OF TERMS

Term	Description
BMS	Building Management System A digital/computer-based control system for a building's infrastructure.
HMI	Human Machine Interface A device that provides a control and visualisation interface between a human and a process or machine.
SCADA	Supervisory Control And Data Acquisition A system that operates with coded signals over communication channels to provide control and monitoring of remote equipment.
RS485	An international serial communications standard.
DSENet	The communications link between a DSE module and expansion modules.

1.3 BIBLIOGRAPHY

This document refers to, and is referred by the following DSE publications which are obtained from the DSE website: www.deepseaelectronics.com or by contacting DSE technical support: support@deepseaelectronics.com.

1.3.1 INSTALLATION INSTRUCTIONS

Installation instructions are supplied with the product in the box and are intended as a 'quick start' guide only.

DSE Part	Description
053-154	DSE2541 Installation Instructions
053-251	DSE BC2410Ei Installation Instructions

1.3.2 MANUALS

Product manuals are obtained from the DSE website: www.deepseaelectronics.com or by contacting DSE technical support: support@deepseaelectronics.com.

DSE Part	Description
N/A	DSEGencomm (MODBUS Protocol for DSE Products)
057-151	DSE Configuration Suite PC Software Installation & Operation Manual
057-220	Options for Communications with DSE Controllers
057-277	DSE2541 Operator Manual
057-315	DSE BC2410Ei PC Software Manual

1.3.3 TRAINING GUIDES

Training guides are provided as 'hand-out' sheets on specific subjects during training sessions and contain specific information regarding to that subject.

DSE Part	Description
056-006	Introduction to Comms
056-030	Module PIN Codes
056-036	DSE Module Expansion
056-069	Firmware Update
056-076	Reading DSEGencomm Alarms
056-079	Reading DSEGencomm Status
056-080	MODBUS

2 SPECIFICATION

2.1 PART NUMBERING

At the time of this document production, there are two variants of this product.

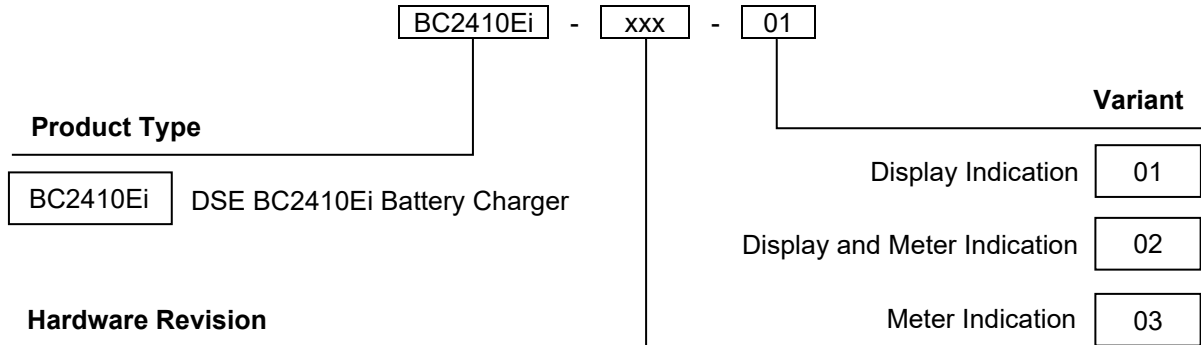

2.2 OPERATING TEMPERATURE

NOTE: The battery charger’s maximum output current de-rates due to excessive temperature and low AC supply voltage. This is done to prevent damage to battery charger and the connected battery/equipment. For further information see section entitled *Output De-rate Curves* elsewhere in this document.

Parameter	Specification
Operating Temperature	-30 °C to +55 °C (-22 °F to +131 °F)
Operating Temperature With De-rate to Output	-40 °C to +80 °C (-40 °F to +176 °F)
Storage Temperature	-40 °C to +80 °C (-40 °F to +176 °F)

2.3 REQUIREMENTS FOR UL CERTIFICATION

 **WARNING!** More than one live circuit exists, see diagram in section entitled *Typical Wiring Diagram* for further information.

Parameter	Comment
Screw Terminal Tightening Torque	4.4 lb-in (0.4 Nm)
Conductors	Terminals suitable for connection of conductor size 20 AWG -13 AWG (2.0 mm ² to 2.5 mm ²). Conductor protection must be provided in accordance with NFPA 70, Article 240. Low voltage circuits (35 V or less) must be supplied from the engine starting battery or an isolated secondary circuit. The communication, sensor, and/or battery derived circuit conductors shall be separated and secured to maintain at least ¼" (6 mm) separation from the generator and mains connected circuit conductors unless all conductors are rated 600 V or greater.
Communication Circuits	Must be connected to communication circuits of UL Listed equipment
Mounting	Suitable for use in type 1 Enclosure Type rating with surrounding air temperature -22 °F to +131 °F (-30 °C to +55 °C). Suitable for pollution degree 3 environments when voltage sensing inputs do not exceed 300 V. When used to monitor voltages over 300 V device to be installed in an unventilated or filtered ventilation enclosure to maintain a pollution degree 2 environment.
Operating Temperature	-22 °F to +131 °F (-30 °C to +55 °C)
Storage Temperature	-40 °F to +176 °F (-40 °C to +80 °C)

2.4 TERMINAL SPECIFICATION

Parameter	Specification	
Connection Type	PCB mounted Screw terminal, rising clamp, no internal spring.	 Example showing cable entry and screw terminals of a 6-way connector.
Minimum Cable Size	0.5 mm ² (AWG 20)	
Maximum Cable Size	2.5 mm ² (AWG 13)	
Tightening Torque	0.5 Nm (4.5 lb-in)	
Wire Strip Length	7 mm (9/32")	

2.5 AC SUPPLY

NOTE: The battery charger's maximum output current de-rates due to excessive temperature and low supply voltage to prevent damage to itself and the battery/connected equipment. For further information see section entitled Output De-rate Curves elsewhere in this document.

NOTE: The battery charger's efficiency varies depending on supply voltage. For further information see section entitled *Efficiency Curves* elsewhere in this document.

Parameter	Specification
Minimum Supply Voltage	95 V with Output Current De-rate. 108 V without Output Current De-rate.
Maximum Supply Voltage	305 V
Minimum Supply Frequency	48 Hz
Maximum Supply Frequency	64 Hz
Maximum Supply Current at 12 V Output Configuration	1.5 A _{AC} at V _{in} =230 V _{AC} , V _{out} =14.1 V _{DC} , I _{out} =10 A _{DC} 2.5 A _{AC} at V _{in} =110 V _{AC} , V _{out} =14.1 V _{DC} , I _{out} =10 A _{DC}
Maximum Supply Current at 24 V Output Configuration	3 A _{AC} at V _{in} =230 V _{AC} , V _{out} =28.2 V _{DC} , I _{out} =10 A _{DC} 5 A _{AC} at V _{in} =110 V _{AC} , V _{out} =28.2 V _{DC} , I _{out} =10 A _{DC}
Typical Supply Current with Charge Output Turned Off/Disconnected	0.05 A _{AC} Irrespective of Supply Voltage.
Supply Inrush Current	60 A for 10 ms
Recommended Fuse	3.5 A anti-surge for 110 V 6.3 A anti-surge for 230 V
Efficiency	More Than 87 % at V _{out} =24.0 V _{DC} , I _{out} =10 A _{DC}
Maximum Power Loss	35 W

2.5.1 EFFICIENCY CURVES

**Efficiency With a Supply Voltage Between 108 V and 305 V
and an Output at 24 V, 10 A**

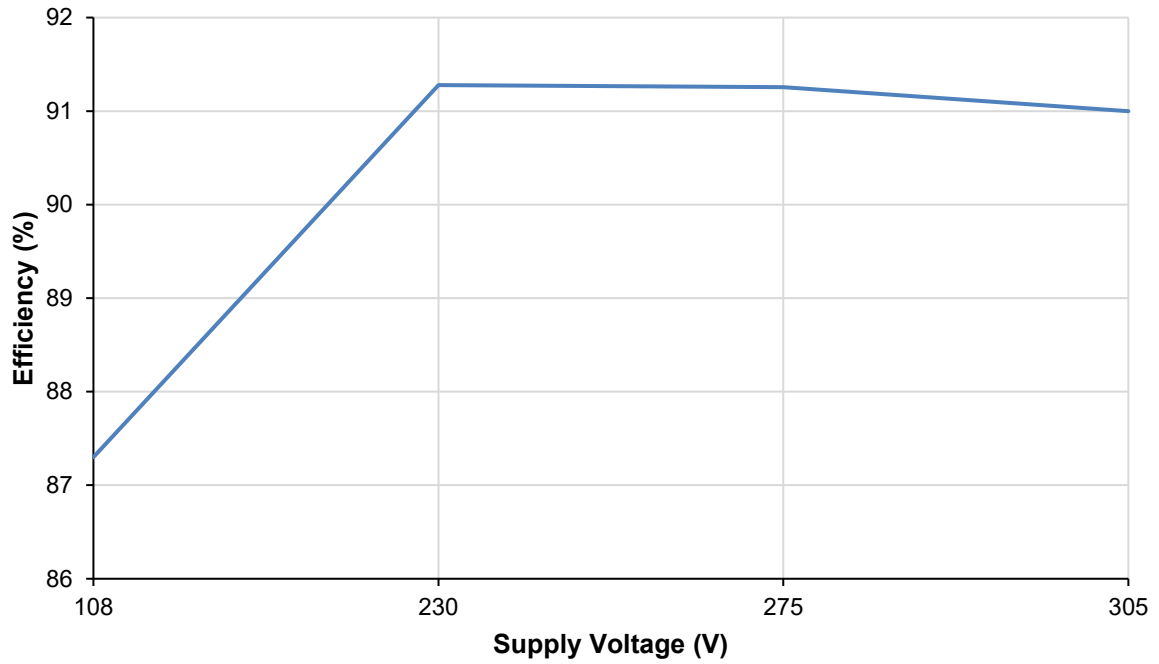

**Efficiency With a Supply Voltage Between 95 V and 110 V
and an Output at 24 V, 5 A**

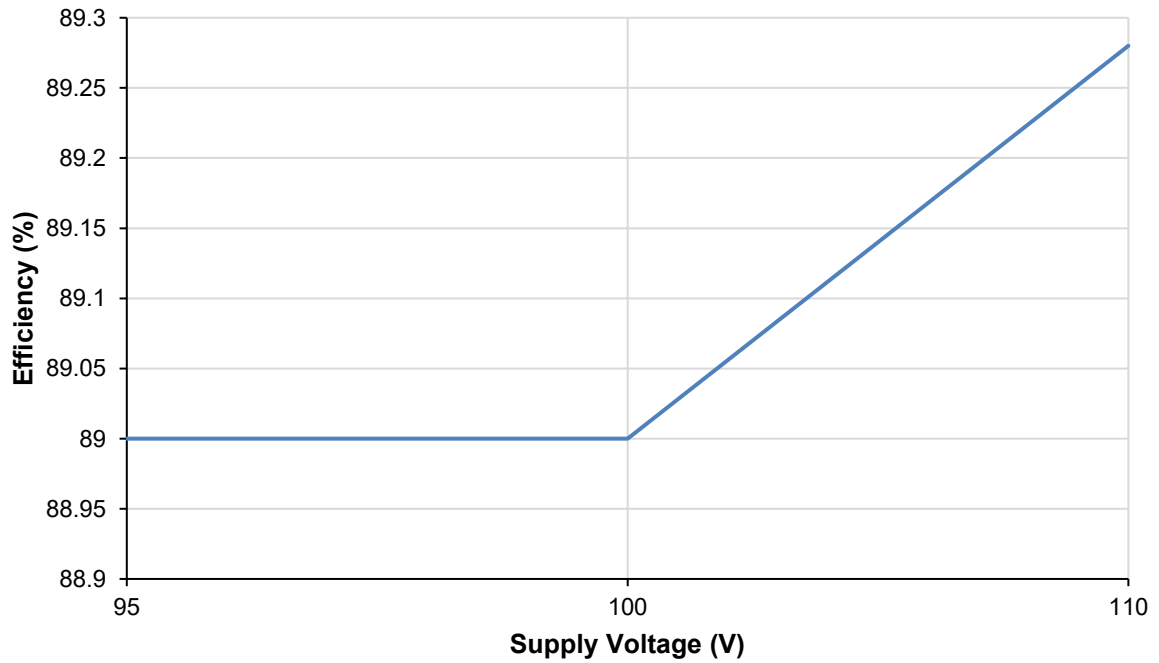

2.6 DC OUTPUT

NOTE: The battery charger is factory configured to automatically detect if the battery is at 12 V or 24 V . It is possible to configure the battery charger with a fixed output to 12 V or 24 V. For further details of the module configuration for the, refer to DSE Publication: *057-315 DSE BC2410Ei Configuration Suite PC Software Manual*.

NOTE: The battery charger is factory configured to suit typical vented wet lead acid batteries. It is possible to configure the battery charger to suit other battery types. For further details of the module configuration, refer to DSE Publication: *057-315 DSE BC2410Ei Configuration Suite PC Software Manual*.

NOTE: The battery charger's maximum output current de-rates due to excessive temperature and low supply voltage to prevent damage to itself and the battery/connected equipment. For further information see section entitled *Output De-rate Curves* elsewhere in this document.

Parameter	Specification
Output Voltage Range Configured for 12 V	12 V to 15.5 V
Output Voltage Range Configured for 24 V	24 V to 31 V
Output Current Range	0 A to 5 A with Maximum Output Current De-rate. 0 A to 10 A without Output Current De-rate.
Configurable Current Limit Range	1 A to 10 A
Output Voltage Ripple and Noise	Less Than 1 % of Configured <i>Boost Voltage</i> at 10 A
Output Voltage Load Regulation	2 %
Output Voltage Line Regulation	Less Than 0.01 % of Requested Output Voltage.
Output Voltage Overshoot %	Less Than 5 % of Requested Output Voltage.
Transient Response Peak Deviation (at 50% to 100% load step)	Less Than 4 % of Requested Output Voltage.
Warm Up Voltage	Less Than 1 % of Requested Output Voltage.
Output Voltage Rise Time	Less Than 200 ms
Short Circuit Protection Type	Hiccup
Switching Frequency	67 kHz
Current Limit Accuracy	±10% of Configured <i>Current Limit</i> .
Maximum Current Draw from Battery During Mains Failure	Less than 90 mA at 12 V Less than 70 mA at 24 V
Maximum Current Draw from Battery During Mains Failure with <i>Sleep Mode</i> Enabled	Less than 12 mA at 12 V and 24 V
Maximum Current Draw from Battery During Mains Failure with <i>Deep Sleep Mode</i> Enabled	Less than 7 mA at 12 V and 24 V

2.6.1 OUTPUT DE-RATE CURVES

Output Current De-rate With Ambient Temperature Greater Than 55°C

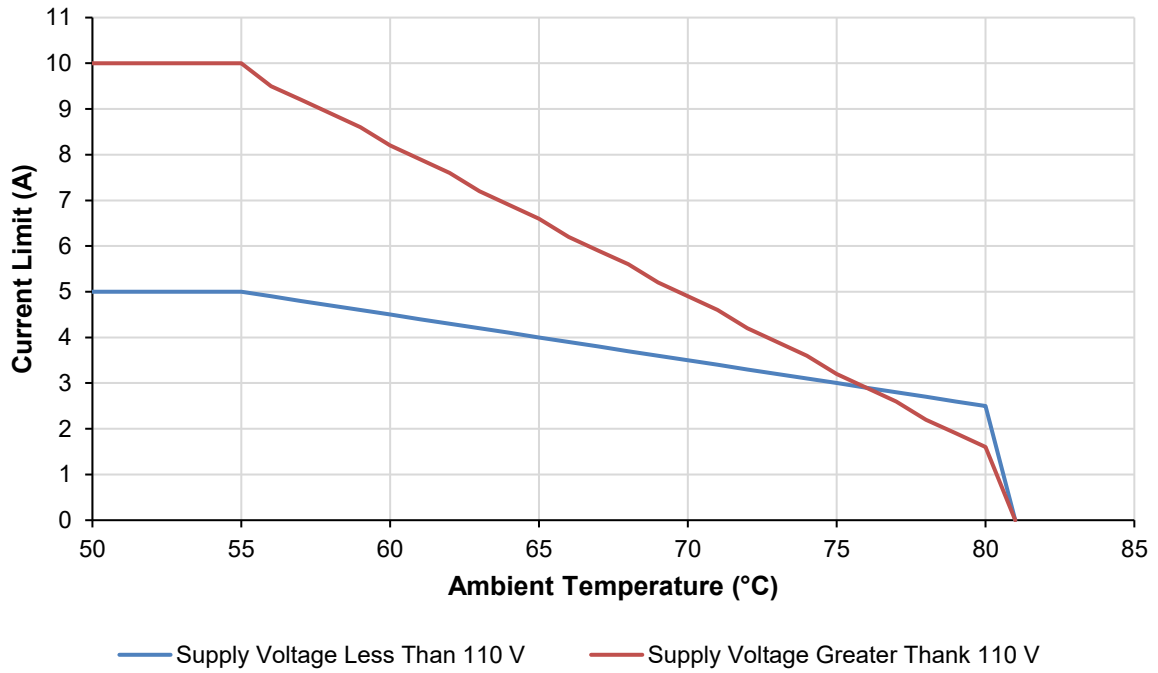

Output Current De-Rate With a Supply Voltage Less Than 110 V and Ambient Temperature of Less Than 55 °C

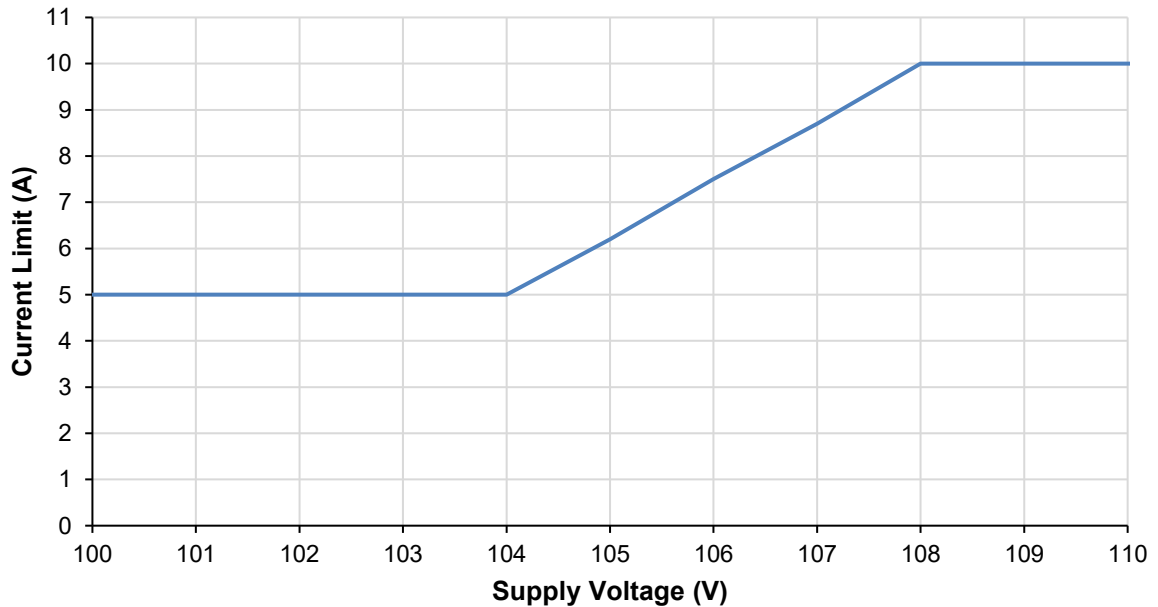

2.7 INPUTS

2.7.1 DIGITAL INPUT

Parameter	Specification
Number	1 configurable digital input
Arrangement	Contact between LK1 terminals
Low Level Threshold	2.1 V minimum
High Level Threshold	6.6 V maximum
Contact Wetting Current	7 mA typical
Open Circuit Voltage	10.2 V typical

2.7.2 TEMPERATURE SENSOR

Parameter	Specification
Temperature Sensor Input	PT1000

2.8 CHARGE FAIL OUTPUT RELAY

Parameter	Specification
Type	Volt-free changeover contacts used to switch an auxiliary circuit to indicate charger output failure.
Rating	3 A resistive at 30 V DC

2.9 COMMUNICATION PORTS

 **NOTE: All communication ports are usable at the same time.**

Parameter	Specification
USB Device Port	Type B USB 2.0 For connection to PC running DSE Configuration Suite Max distance 5 m (16 feet)
Communication Port (Configurable for RS485 or DSENet communications)	Isolated Data connection 2 wire + common Half Duplex Data direction control for Transmit (by s/w protocol) Max Baud Rate 115.2 kbaud subject to configuration External termination required (120 Ω) Max common mode offset 70 V (on board protection transorb) Max distance 1.2 km (¾ mile)

2.10 COMMUNICATION PORT USAGE

2.10.1 USB DEVICE PORT (PC CONFIGURATION)

NOTE: DSE stock 2 m (6.5 feet) USB type A to type B cable, DSE Part Number: 016-125. Alternatively, they are purchased from any PC or IT store.

NOTE: The battery must be connected to the battery charger for configuration by PC.

NOTE: For further details of module configuration, refer to DSE Publication: 057-315 *DSE BC2410Ei Configuration Suite PC Software Manual*.

The USB port is provided to give a simple means of connection between a PC and the battery charger. Using the DSE Configuration Suite Software, the operator is then able to configure and monitor the state of the battery charger.

To connect a module to a PC by USB, the following items are required:

- DSE Enclosed Intelligent Battery Charger.
- DSE Configuration Suite PC Software (Available from www.deepseaelectronics.com).
- USB cable Type A to Type B.
(This is the same cable as often used between a PC and a USB printer).

DSE can supply this cable if required:
PC Configuration interface lead (USB type A – type B)
DSE Part No 016-125

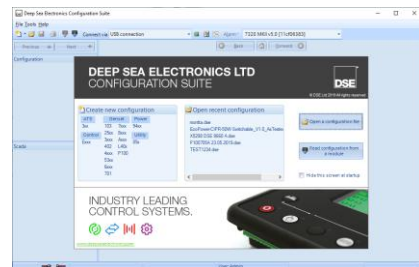

2.10.2 COMMUNICATION PORT

NOTE: The RS485 communications port is configurable for RS485 or DSENet use. For further details of module configuration, refer to DSE Publication: 057-315 *DSE BC2410Ei Configuration Suite PC Software Manual*.

2.10.2.1 CABLE SPECIFICATION

NOTE: DSE recommend Belden 9841 (or equivalent) cable for RS485 communication. This is rated to a maximum cable length of 1.2 km. DSE Stock Belden 9841 cable, DSE Part Number: 016-030.

Description	Specification
Cable Type	Two core screened and shielded twisted pair.
Cable Characteristics	120 Ω impedance. Low capacitance.
Recommended Cable	Belden 9841. Belden 9271.
Maximum Cable Length	1.2 km (¾ mile) when using Belden 9841 or direct equivalent. 600 m (656 yards) when using Belden 9271 or direct equivalent.
Topology	“Daisy Chain” Bus with no stubs (spurs).
RS485 Termination	120 Ω . Not fitted internally to module. Must be fitted externally to the ‘first’ and ‘last’ device on the link.

2.10.2.2 CONFIGURED AS A DSENET PORT

When configured for DSENet, the *Communication Port* must not be connected to any device other than DSE equipment designed for connection to the DSENet®

DSENet® is the interconnection cable between the host controller and the expansion module. It enables the host controller to display information, instrumentation, and alarms from the battery charger on its own display.

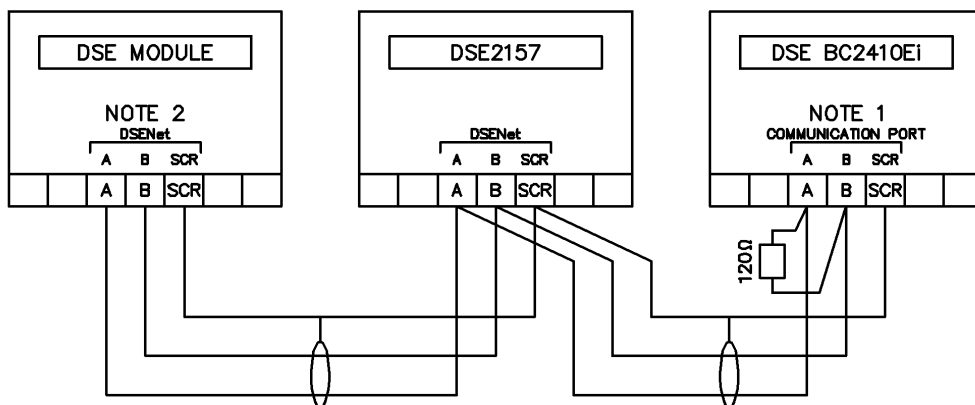

NOTE 1.
IF THE MODULE IS FIRST OR LAST UNIT ON THE LINK IT MUST BE FITTED WITH AN EXTERNAL 120 OHM TERMINATION RESISTOR ACROSS TERMINALS A AND B TERMINALS.

NOTE 2.
MUST BE FITTED AS FIRST OR LAST UNIT ON THE LINK WITH NO EXTERNAL TERMINATION RESISTOR

2.10.2.3 CONFIGURED AS AN RS485 PORT

When configured for RS485, the *Communication Port* must not be connected to a communication link designed for connection to the DSENet®.

The RS485 port on the controller supports the MODBUS RTU protocol and is for connection to a single MODBUS client device only or a single DSE2541 remote display.

2.10.2.3.1 REMOTE DISPLAY

Connecting the DSE2541 display to the battery chargers RS485 port provides remote monitoring and control, in addition to the battery chargers inbuilt display. The DSE2541 provides the same level of monitoring and control as the battery chargers inbuilt display and supports variants of the battery charger.

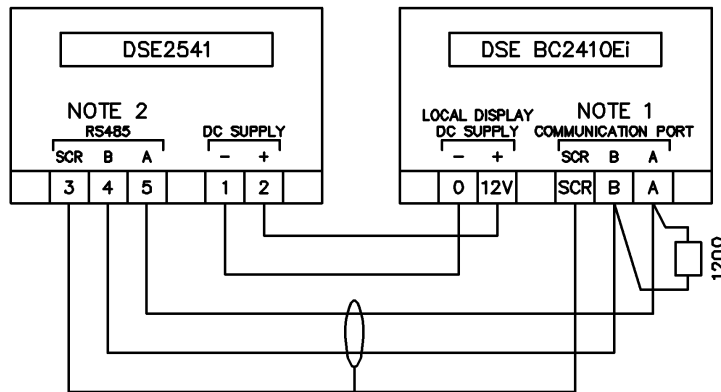

NOTE 1.
A 120 OHM TERMINATION RESISTOR MUST BE FITTED EXTERNALLY

NOTE 2.
A 120 OHM TERMINATION RESISTOR IS FITTED INTERNALLY

2.10.2.3.2 MODBUS SERVER

NOTE: For a single module to PC connection and distances up to 5 m (16 feet) the USB connection method is more suitable and provides for a lower cost alternative to RS485 (which is more suited to longer distance connections).

NOTE: The DSE MODBUS register table for the controller is available upon request from the DSE Technical Support Department.

RS485 is used for point-to-point cable connection of more than one device (maximum 32 devices) and allows for connection to PCs, PLCs and Building Management Systems.

One advantage of the RS485 interface is the large distance specification (1.2 km when using Belden 9841 (or equivalent) cable. This allows for a large distance between the module and a PC running the DSE Configuration Suite software. The operator is then able to control the module, starting or stopping the engine, selecting operating modes, etc.

Many PCs are not fitted with an internal RS485 serial port. DSE DOES NOT recommend the use of USB to RS485 converters but can recommend PC add-ons to provide the computer with an RS485 port.

Recommended PC RS485 Serial Port Add-ons

▲ NOTE: DSE have no business tie to Brainboxes. Over many years, our own engineers have used these products and are happy to recommend them.

▲ NOTE: For further details of setting up the devices below, refer to the manufacture whose details are below.

Remember to check these parts are suitable for your PC. Consult your PC supplier for further advice.

- Brainboxes PM154 PCMCIA RS485 card (for laptops PCs)
Set to 'Half Duplex, Autogating" with 'CTS True' set to 'enabled'.
- Brainboxes VX-023 ExpressCard 1 Port RS422/485 (for laptops and nettop PCs)
- Brainboxes UC320 PCI Velocity RS485 card (for desktop PCs)
Set to 'Half Duplex, Autogating" with 'CTS True' set to 'enabled'
- Brainboxes PX-324 PCI Express 1 Port RS422/485 (for desktop PCs)



Supplier:
Brainboxes
Tel: +44 (0)151 220 2500
Web: <http://www.brainboxes.com>
Email: sales@brainboxes.com

2.11 DIMENSIONS AND MOUNTING

Parameter	Specification
Cabinet Type	Custom cabinet for indoor use only.
Overall Size	170 mm X 305 mm X 116.6 mm (6.69 " X 12.0 " X 4.59 ")
Perimeter Distance From Charger for Ventilation	100 mm (3.9")
Material	Sheet steel enclosure of all-round solid construction.
Surface Finish	Powder-coated black.
Protection Category	IP20, NEMA 1
Weight Unboxed	2.16 kg (4 lb 12 oz)
Weight Boxed	2.34 kg (5 lb 2 oz)
Mounting Type	Base mounted to a vertical surface with connection terminals to the bottom.
Mounting Holes	Diameter 7 mm (0.276 "), 63.5 mm X 291 mm (2.5 " x 11.46 ") centres
Cable Entry Cutout	Diameter 20 mm (0.78 ")
Operating Temperature	-30 °C to +55 °C (-22 °F to +131 °F)
Operating Temperature (With De-rate To Output)	-30 °C to +80 °C (-22 °F to +176 °F)

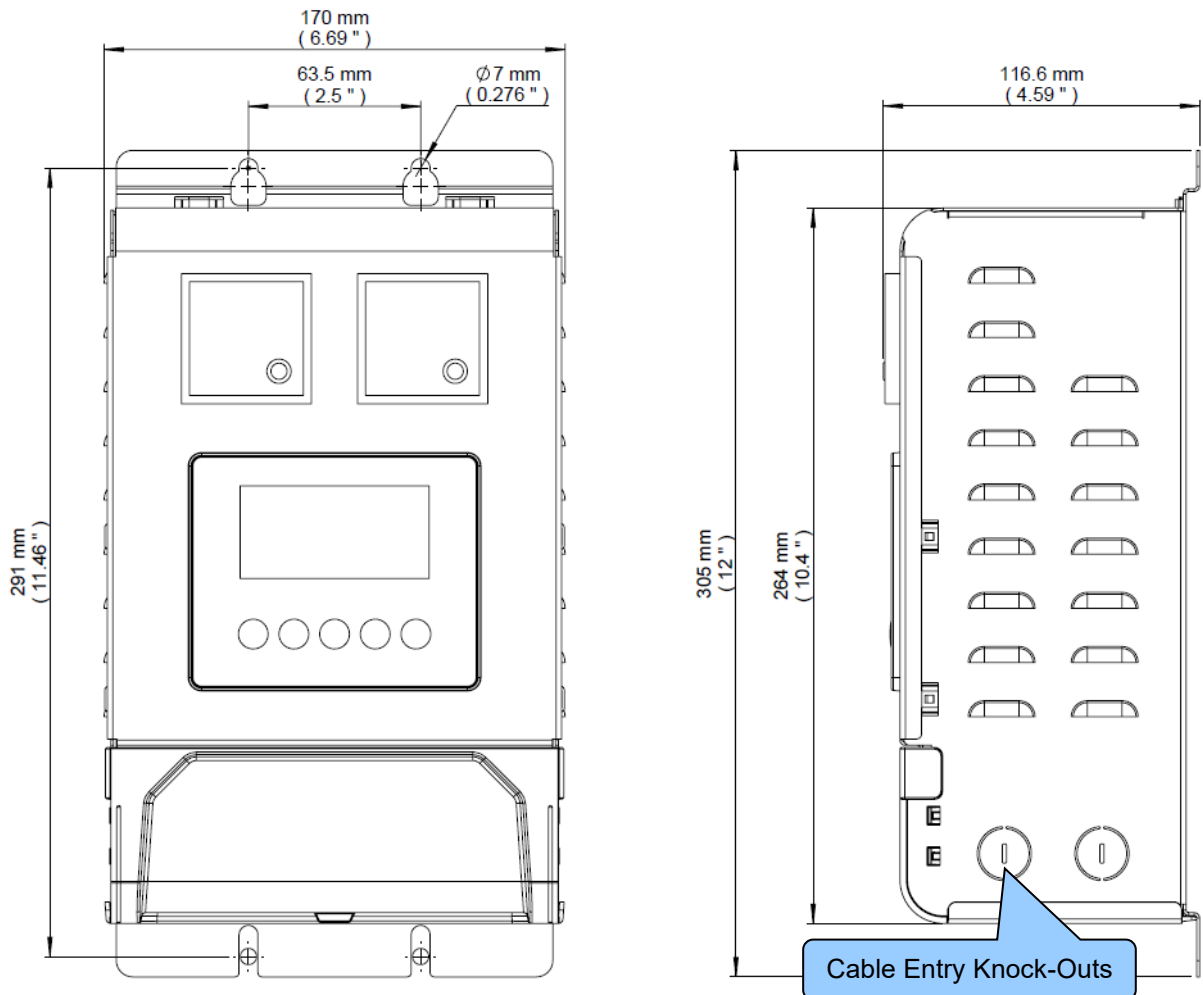

2.12 APPLICABLE STANDARDS

Standard	Description
BS 4884-1	This document conforms to BS4884-1 1992 Specification for presentation of essential information.
BS 4884-2	This document conforms to BS4884-2 1993 Guide to content.
BS 4884-3	This document conforms to BS4884-3 1993 Guide to presentation.
BS EN 60068-2-1 (Minimum temperature)	-30°C (-22 °F)
BS EN 60068-2-2 (Maximum temperature)	+80°C (176 °F)
BS EN 60950 BS EN 60335-1 BS EN 60335-2-29:2004+A2:2010	Safety of information technology equipment, including electrical business equipment.
BS EN 61000-6-2	EMC Generic Immunity Standard (Industrial).
BS EN 61000-6-4	EMC Generic Emission Standard (Industrial).
BS EN 60529 (Degrees of protection provided by enclosures)	IP20 Protected against penetration by solid objects with a diameter of more than 12 mm. Fingers or similar objects prevented from approach. No protection against water.
UL508 NEMA Rating	Enclosure type 1 Provides a degree of protection against contact with the enclosure equipment and against a limited amount of falling dirt.
UK WEEE Regulations	Producer Registration Number WEE/BE0052TQ

In line with our policy of continual development, Deep Sea Electronics, reserve the right to change specification without notice.

2.12.1 ENCLOSURE CLASSIFICATIONS

2.12.1.1 IP CLASSIFICATIONS

The modules specification under BS EN 60529 Degrees of protection provided by enclosures

IP20 Highlighted fields give a description of the of the protection level

First Digit	Second Digit
Protection against contact and ingress of solid objects	Protection against ingress of water
0 No protection	0 No protection
1 Protected against ingress solid objects with a diameter of more than 50 mm. No protection against deliberate access, e.g. with a hand, but large surfaces of the body are prevented from approach.	1 Protection against dripping water falling vertically. No harmful effect must be produced (vertically falling drops).
2 Protected against penetration by solid objects with a diameter of more than 12 mm. Fingers or similar objects prevented from approach.	2 Protection against dripping water falling vertically. There must be no harmful effect when the equipment (enclosure) is tilted at an angle up to 15° from its normal position (drops falling at an angle).
3 Protected against ingress of solid objects with a diameter of more than 2.5 mm. Tools, wires etc. with a thickness of more than 2.5 mm are prevented from approach.	3 Protection against water falling at any angle up to 60° from the vertical. There must be no harmful effect (spray water).
4 Protected against ingress of solid objects with a diameter of more than 1 mm. Tools, wires etc. with a thickness of more than 1 mm are prevented from approach.	4 Protection against water splashed against the equipment (enclosure) from any direction. There must be no harmful effect (splashing water).
5 Protected against harmful dust deposits. Ingress of dust is not totally prevented but the dust must not enter in sufficient quantity to interface with satisfactory operation of the equipment. Complete protection against contact.	5 Protection against water projected from a nozzle against the equipment (enclosure) from any direction. There must be no harmful effect (water jet).
6 Protection against ingress of dust (dust tight). Complete protection against contact.	6 Protection against heavy seas or powerful water jets. Water must not enter the equipment (enclosure) in harmful quantities (splashing over).

2.12.1.2 NEMA CLASSIFICATIONS

 **NOTE: There is no direct equivalence between IP / NEMA ratings. IP figures shown are approximate only.**

NEMA1 Highlighted fields give a description of the of the protection level

1	Provides a degree of protection against contact with the enclosure equipment and against a limited amount of falling dirt.
IP30	
2	Provides a degree of protection against limited amounts of falling water and dirt.
IP31	
3	Provides a degree of protection against windblown dust, rain and sleet; undamaged by the formation of ice on the enclosure.
IP64	
3R	Provides a degree of protection against rain and sleet; undamaged by the formation of ice on the enclosure.
IP32	
4 (X)	Provides a degree of protection against splashing water, windblown dust and rain, hose directed water; undamaged by the formation of ice on the enclosure. (Resist corrosion).
IP66	
12/12K	Provides a degree of protection against dust, falling dirt and dripping non-corrosive liquids.
IP65	
13	Provides a degree of protection against dust and spraying of water, oil and non-corrosive coolants.
IP65	

3 INSTALLATION

 **NOTE:** Ensure any standing loads (loads connected to the battery charger other than the battery) are less 75% of the battery charger configured rating. This helps to ensure the charger correctly detects the required battery charge state.

The DSE battery charger is *fit-and-forget*. It can be permanently connected to the supply and the load, with no requirement to disable the charger during times of heavy load (such as engine cranking).

3.1 BATTERY SUITABILITY

 **NOTE:** For further details of module configuration, refer to DSE Publication: 057-315 *DSE BC2410Ei Configuration Suite PC Software Manual*.

The battery charger is factory configured for a *Three Stage* charging profile for Wet (Vented) Lead Acid batteries. The battery charger automatically changes selects 12 V or 24 V operation based on the detected battery voltage. It is possible to reconfigure the battery charger to suit other battery chemistry types using the DSE Configuration Suite PC Software. Care must be taken to ensure the batteries connected to the charger and selected profile are of the correct type.

3.2 USER CONNECTIONS

3.2.1 CONNECTION ACCESS

 **DANGER OF DEATH: LIVE PARTS exist within the enclosure. The enclosure cover must not be removed when connected to a live AC supply.**

Metal 'Push Outs' are available on the side of the charger case to enable the installer to fit rubber grommets or cable glands to facilitate cable entry.

The battery charger's connections are accessed by removing the lower cover:

1. Simultaneously insert both tools as indicated.
2. Lever both tools in the indicated directions.

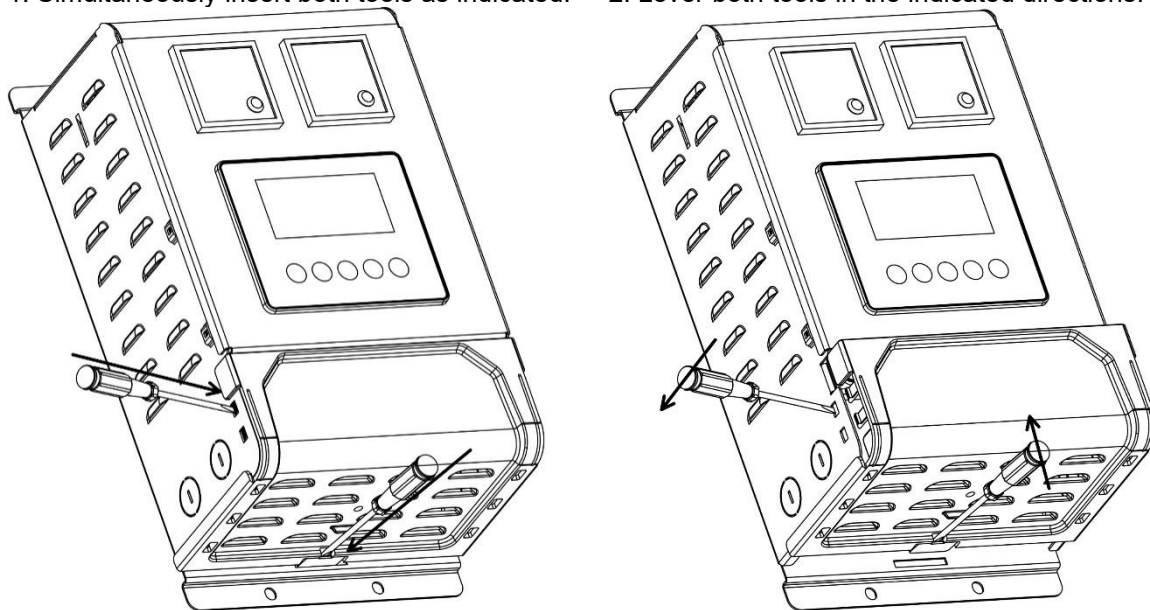

3. Slide off cover in the indicated direction.

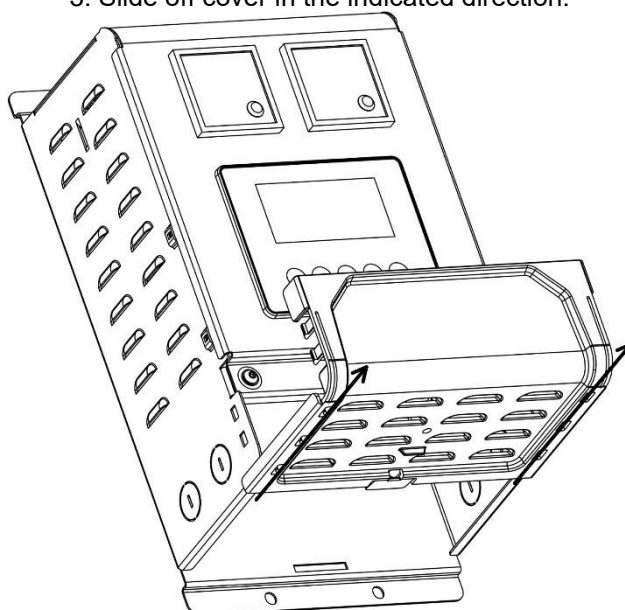

3.2.2 CONNECTION DESCRIPTIONS

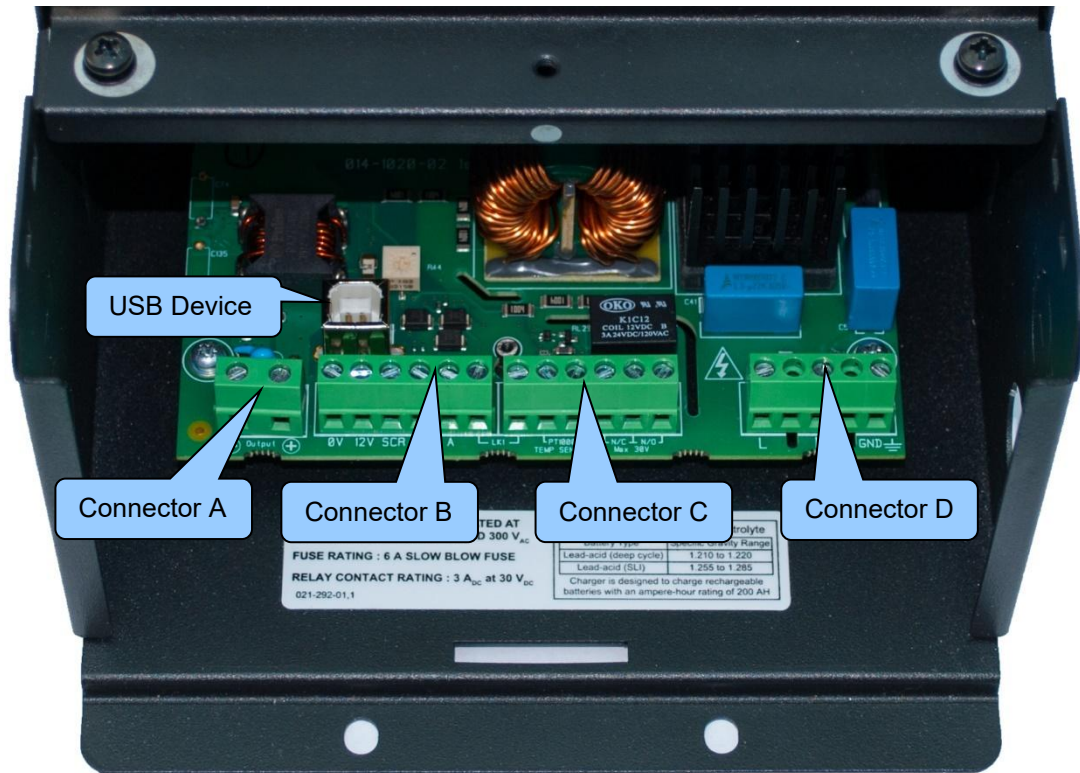

3.2.2.1 CONNECTOR A

NOTE: The battery charger must be connected directly to the battery.

Terminal	Function	Recommended Size	Comments
⊖	Charge Output	1 mm ² (AWG 16)	Connected directly to the battery negative terminal.
⊕	Charge Output	1 mm ² (AWG 16)	Connected directly to the battery positive terminal.

3.2.2.2 CONNECTOR B / C

NOTE: Screened 120Ω impedance cable specified for use with RS485 must be used for the RS485 link. DSE stock and supply Belden cable 9841 which is a high quality 120Ω impedance cable suitable for RS485 use (DSE part number 016-030)

Terminal	Function	Recommended Size	Comments
0V	Supply for a remote DSE2541 display	1 mm ² (AWG 16)	
12V		1 mm ² (AWG 16)	
SCR	Communication screen	Shield	Use only 120Ω RS485 approved cable.
B	Communication B (+)	0.5 mm ² (AWG 20)	
A	Communication A (-)	0.5 mm ² (AWG 20)	
LK1	Link together to activate Digital Input	0.5 mm ² (AWG 20)	Input Function Configured using DSE Configuration Suite PC Software
LK1		0.5 mm ² (AWG 20)	
PT1000	2 wire PT1000 temperature sensor	0.5 mm ² (AWG 20)	Use only a 2 wire PT1000 temperature sensor.
PT1000		0.5 mm ² (AWG 20)	
N/C	Fault relay Normally Closed terminal	0.5 mm ² (AWG 22)	De-energises under Fault Conditions.
Common	Fault relay Common Terminal	0.5 mm ² (AWG 22)	
N/O	Fault relay Normally Open terminal	0.5 mm ² (AWG 22)	

3.2.2.3 CONNECTOR D

Parameter	Specification	
Recommended AC Fuse	230 V_{AC} Input 3.5 A anti-surge	110 V_{AC} Input 6.3 A anti-surge



Terminal	Function	Recommended Size
L	AC Live	1mm ² (AWG 16)
N	AC Neutral	1mm ² (AWG 16)
	Earth	1mm ² (AWG 16)

3.2.2.4 USB DEVICE (PC CONFIGURATION) CONNECTOR

NOTE: The USB connection cable between the PC and the module must not be extended beyond 5 m (16 feet). For distances over 5 m, it is possible to use a third-party USB extender. Typically, they extend USB up to 50 m. The supply and support of this type of equipment is outside the scope of Deep Sea Electronics LTD.

CAUTION!: Care must be taken not to overload the PCs USB system by connecting more than the recommended number of USB devices to the PC. For further information, consult your PC supplier.

NOTE: For further details of module configuration, refer to DSE Publication: 057-238 *DSE BC2410Ei Configuration Suite PC Software Manual*.

	Description	Cable Size	Notes
	Socket for connection to PC with DSE Configuration Suite Software	0.5 mm ² AWG 20	This is a standard USB type A to type B connector. 

3.2.2.5 CABLE ENTRY

The unit has 4 'knock-outs' for use with M20 glands/gromets or conduit to facilitate cable entry. They are removed by inserting a screwdriver into the slot and twisting to shear.

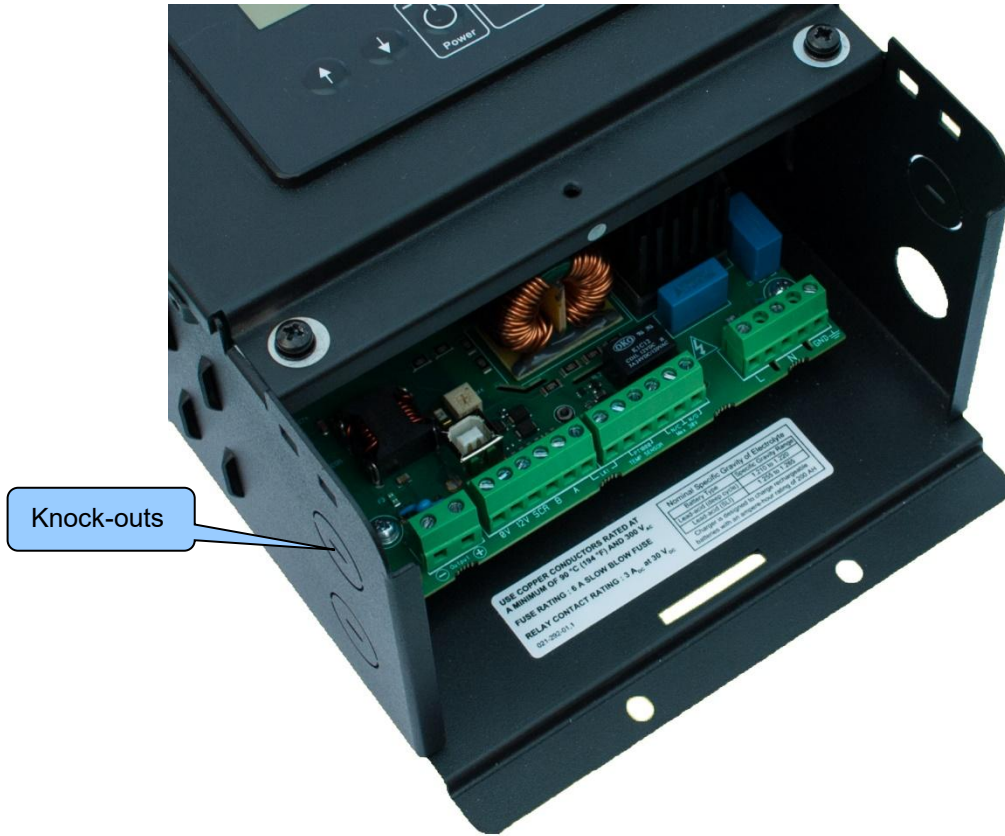

3.3 TYPICAL WIRING DIAGRAM

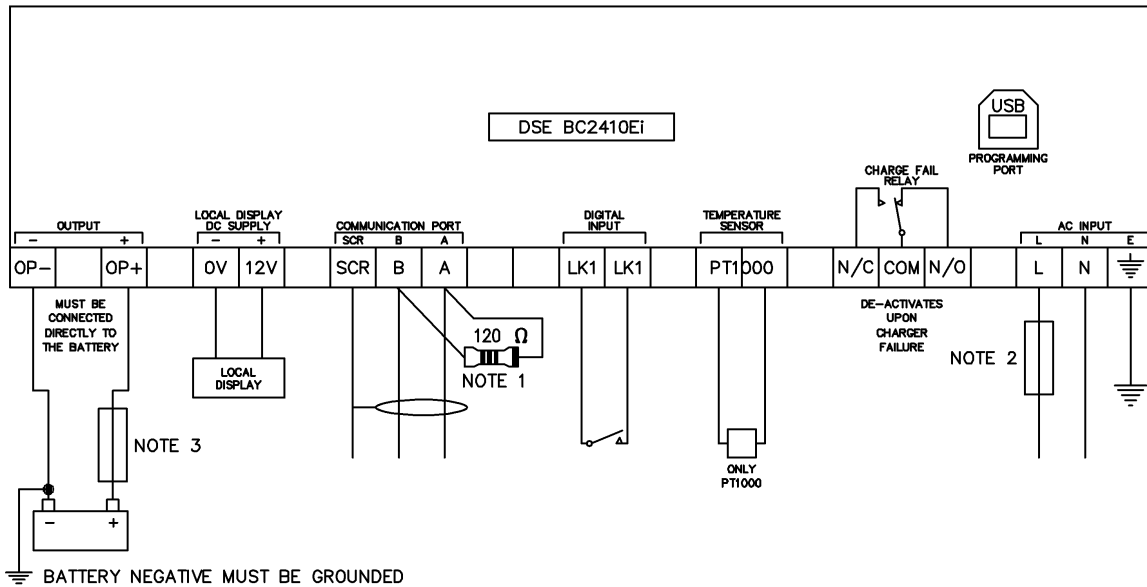

- NOTE 1
A 120 OHM TERMINATION RESISTOR MUST BE FITTED IF IT IS THE FIRST OR LAST DEVICE ON THE COMMUNICATIONS LINK
- NOTE 2
FUSE APPROPRIATELY WHEN BASED ON CONFIGURED CHARGE CURRENT LIMIT AND AS CLOSE TO THE BATTERY CHARGER AS POSSIBLE TO PROTECT THE CABLES
- NOTE 3
FUSE APPROPRIATELY AND AS CLOSE TO THE BATTERY AS POSSIBLE TO PROTECT THE CABLES AND BATTERY

3.3.1 EARTH SYSTEMS

3.3.1.1 NEGATIVE EARTH

The typical wiring diagrams located within this document show connections for a negative earth system (the battery negative connects to Earth).

3.3.1.2 POSITIVE EARTH

When using a DSE module with a Positive Earth System (the battery positive connects to Earth), the following points must be followed:

Follow the typical wiring diagram as normal for all sections **except** the earth points. All points shown as Earth on the typical wiring diagram should connect to **battery negative** (not earth).

3.3.1.3 FLOATING EARTH

Where neither the battery positive nor battery negative terminals are connected to earth the following points must be followed:



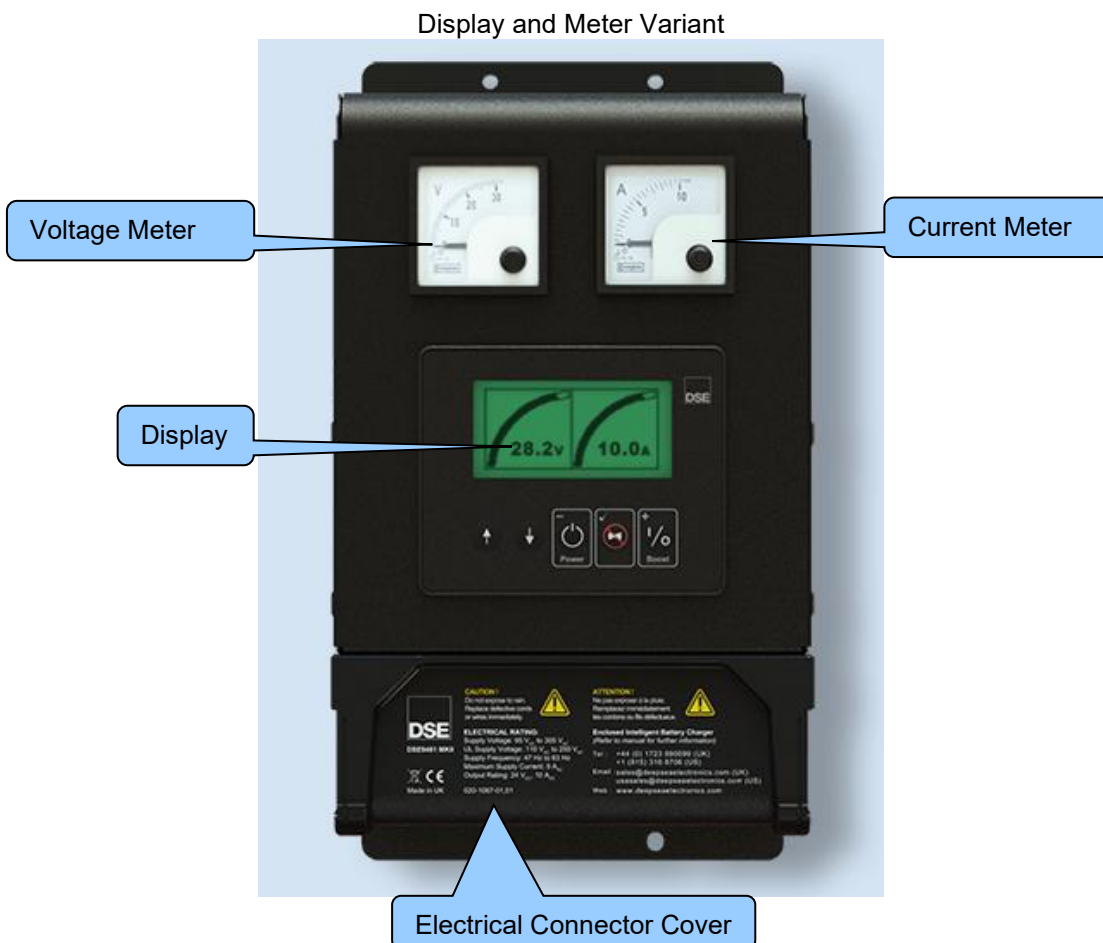

Follow the typical wiring diagram as normal for all sections **except** the earth points. All points shown as Earth on the typical wiring diagram should connect to **battery negative** (not earth).

4 DESCRIPTION OF CONTROLS



NOTE: When using the Meter only variant, viewing of the instrumentation and performing diagnostic checks must be done using the DSE Configuration Suite PC Software. For further details, refer to DSE Publication: 057-238 *DSE BC2410Ei Configuration Suite PC Software Manual*.



4.1 CONTROL PUSH BUTTONS

Button	Description
	Menu Navigation Used for navigating the instrumentation, event log and configuration screens.
	Power Toggles the power output of the battery charger when <i>Control Mode</i> page is displayed. Also used for the decrement function (-) in the Front Panel Editor.
	Alarm Mute / Select Used for entering and exiting the Front Panel Editor. Also selecting items to configure within the front panel editor.
	Boost Toggles the boost mode on the battery charger when <i>Control Mode</i> page is displayed. Also used for the increment function (+) in the Front Panel Editor.

4.2 VIEWING THE INSTRUMENT PAGES

Press the navigation buttons  (up) and  (down) to cycle through the available instrumentation screens. When the last screen is reached the menu cycles back around to the home screen with the next press of the button.

4.2.1 HOME SCREEN

The analogue meters home screen shows the visual representation of the charger output voltage and current, relative to their configured maximum outputs.

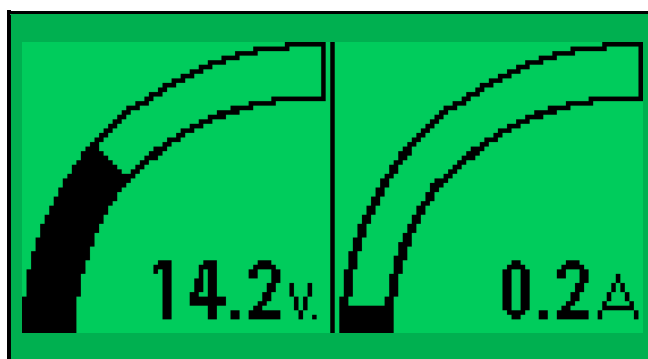

4.2.2 INSTRUMENTATION SCREENS

The screen layout is displayed as shown below and the order of the information and data is shown in the accompanying tables.

	Alarm Icon	Instrument Icon
Instrumentation	Battery Icon	
	Charge Timer	

Example Display Screen









Alarm Icon

The *Display Icon* is located on the top of the *Display Screens*. It indicates when there is an active alarm on the battery charger.

Alarm Icon	Description
	The icon appears when there is an active alarm on the battery charger. Navigate to the <i>Alarms</i> page by pressing the navigation buttons (up) or (down) to see what alarm is active.







Display Icon

The *Display Icon* is located on the top right side of the *Display Screens*. It indicates the which display screen is currently being viewed.

Display Icon	Description
	Battery Charger Output Measurements 1 and 2.
	Battery
	AC Supply Measurements
	Battery Charger Information
	Battery Charger Operating Mode
	Battery Charger Active Alarms

Battery Icon

The *Battery Icon* is located on the right side of the *Display Screens*. It indicates the battery chargers current charging state.

Battery Icon	Description
	Not Charging
	Bulk/Boost
	Absorption
	Float
	Storage
	Fault

Charge Timer

The *Charge Timer* is used in conjunction with the *Battery Icon* to indicates the remaining time for the absorption, float or storage charging stage as configured within the battery charger.

4.2.2.1 BATTERY CHARGER OUTPUT

These display screens show the battery chargers output voltage, current and power, and its temperature.

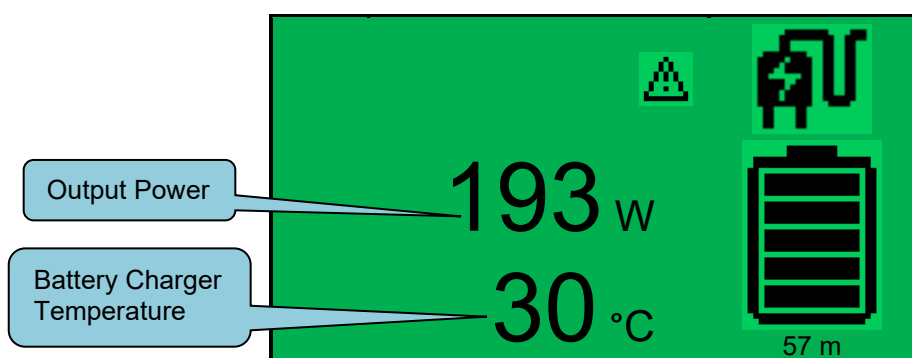
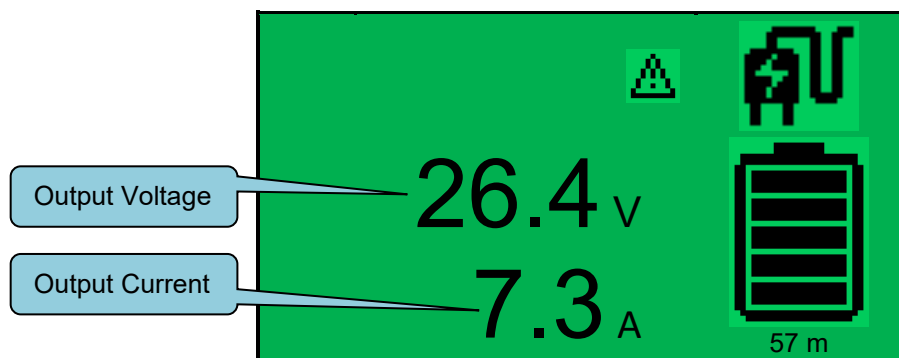

4.2.2.2 BATTERY

This display screen shows the measured battery voltage from the remote sense terminals and the battery's temperature from the PT1000 input.

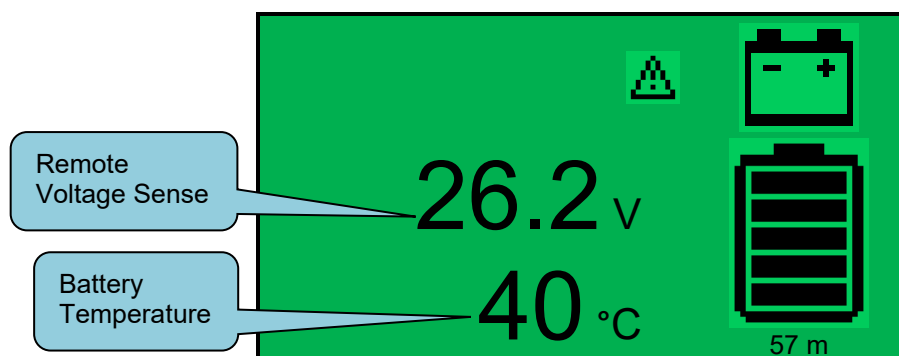

4.2.2.3 AC SUPPLY

This display screen shows the measured AC supply voltage and frequency used to power the battery charger.

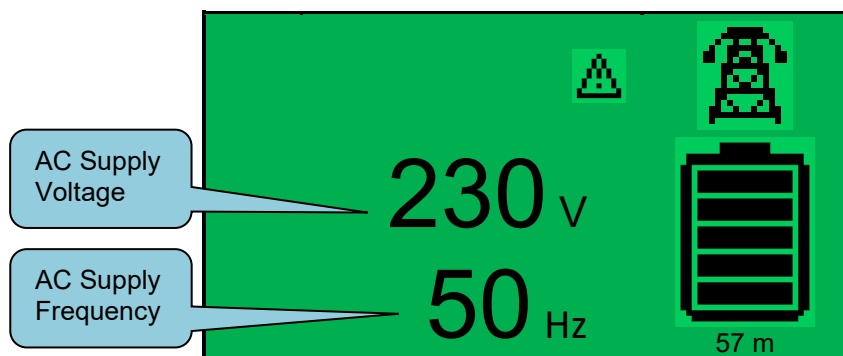

4.2.2.4 BATTERY CHARGER INFORMATION

This display screen shows the model and firmware version of the battery charger.

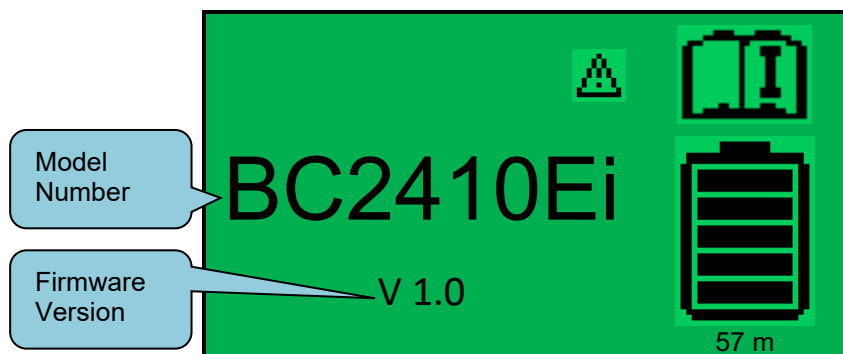

4.2.2.5 BATTERY CHARGER OPERATING MODE

This display screen shows the current operating mode of the battery charger and when being viewed, enables the operating to change the operating mode by pressing the display fascia buttons.

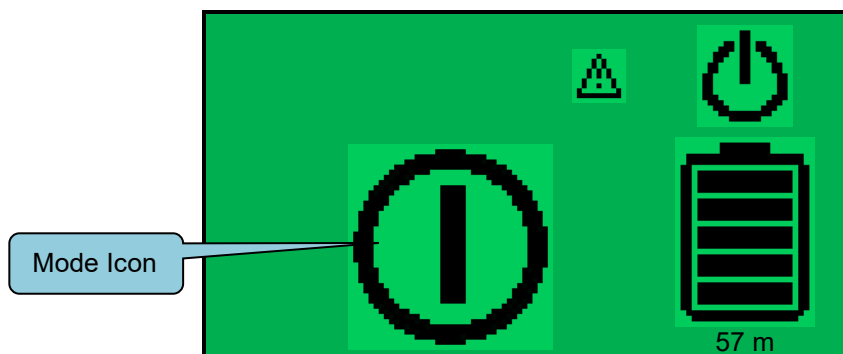

Mode Icon	Battery Charger Output
	On
	Off
	Boost





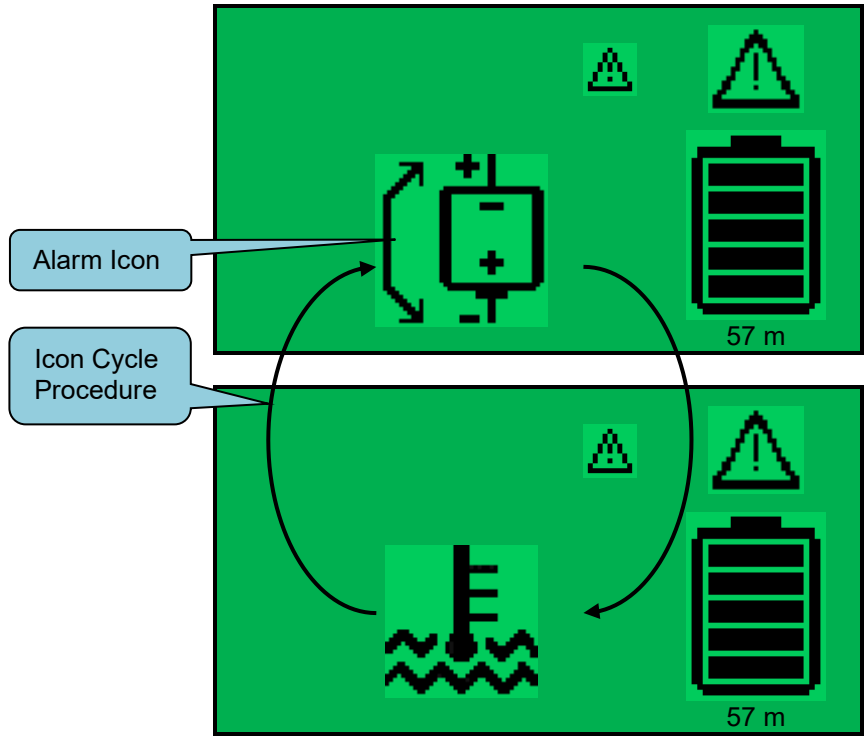

4.2.2.6 BATTERY CHARGER ACTIVE ALARMS

When a new alarm is detected, the LCD displays the alarm screen. If multiple alarms are active at the same time, the **Alarm Icon** automatically cycles through all the appropriate icons to indicate each alarm which is active.











4.2.2.6.1 WARNING ALARMS

Warning Alarms are pre-critical fault conditions and when active cause the battery charger's output voltage to fall to the configured *Float Voltage* level. The *Charge Failure Relay* does activate based on Warning Alarms. All Warning Alarms are self-resetting when the fault condition is removed or rectified.

Icon	Alarm	Description
	Battery Over Voltage	The battery charger has detected that the battery voltage has risen above the configured <i>Over Voltage Alarm</i> level for longer than the <i>Alarm Delay</i> . The alarm automatically clears once the battery voltage has fallen below the configured <i>Over Voltage Return</i> level for longer than the <i>Return Delay</i> .
	Battery Under Voltage	The battery charger has detected that the battery voltage has fallen below the configured <i>Under Voltage Alarm</i> level for longer than the <i>Alarm Delay</i> . The alarm automatically clears once the battery voltage has risen above the configured <i>Under Voltage Return</i> level for longer than the <i>Return Delay</i> .
	Charger Over Current	The battery charger has detected that its output current has risen above the configured <i>Over Current Alarm</i> level for longer than the <i>Alarm Delay</i> . The alarm automatically clears once the output current has fallen below the configured <i>Over Current Return</i> level for longer than the <i>Return Delay</i> .
	Mains Over Voltage	The battery charger has detected that the AC Supply has risen above the configured <i>Mains Over Voltage Alarm</i> level for longer than the <i>Alarm Delay</i> . The alarm automatically clears once the AC Supply has fallen below the configured <i>Mains Over Voltage Return</i> level for longer than the <i>Return Delay</i> .
	Mains Under Voltage	The battery charger has detected that the AC Supply has fallen below the configured <i>Mains Under Voltage Alarm</i> level for longer than the <i>Alarm Delay</i> . The alarm automatically clears once the AC Supply has risen above the configured <i>Mains Under Voltage Return</i> level for longer than the <i>Return Delay</i> .
	Battery Over Temperature	The battery charger has detected that the battery temperature has risen above the configured <i>Battery Temperature Warning Alarm</i> level for longer than the <i>Alarm Delay</i> . The alarm automatically clears once the battery temperature has fallen below the configured <i>Battery Temperature Warning Return</i> level for longer than the <i>Return Delay</i> .
	PTC Failure	The battery charger has detected that the PT1000 temperature sensor is in a faulting state (open/short circuit or under/over measurable range). The alarm automatically clears once the battery charger detects a valid temperature reading.

4.2.2.6.2 SHUTDOWN ALARMS

Shutdown Alarms are critical fault conditions that disable the battery charger's output and activates the *Charge Failure Relay*. Majority of the Shutdown Alarms are self-resetting when the fault condition is removed or rectified.

Icon	Alarm	Description
	Battery Over Voltage	The battery charger has detected that the battery voltage has risen above 32 V and has exceeded the operating specification. This alarm must be manually reset by disconnecting the battery charger. If the problem persists the battery charger must be replaced or repaired.
	Charger Over Current	The battery charger has detected that the output current has risen above 115 % of the configured current limit. This alarm must be manually reset by disconnecting the battery charger. If the problem persists the battery charger must be replaced or repaired.
	Mains Over Voltage	The battery charger has detected that the AC Supply voltage has risen above 310 V and has exceeded the operating specification. The alarm automatically clears once the AC Supply voltage has fallen below 305 V.
	Mains Under Voltage	The battery charger has detected that the AC Supply voltage has fallen below 90 V and has exceeded the operating specification. The alarm automatically clears once the AC Supply voltage has risen above 95 V.
	Battery Over Temperature	The battery charger has detected that the battery temperature has risen above the configured <i>Battery Temperature Shutdown Alarm</i> level. The alarm automatically clears once the battery temperature has fallen below the configured <i>Battery Temperature Shutdown Return</i> level.
	Charger Over Temperature	The battery charger has detected that the ambient temperature has risen above 81 °C and has exceeded the operating specification. The alarm automatically clears once the ambient temperature falls below 50 °C.
	Short Circuit or Reverse Polarity	The battery charger has detected that a battery was connected with a reverse polarity, or a short circuit has occurred to its output voltage terminals for longer then the configured <i>Delay</i> time. The alarm automatically clears once the reverse polarity or short circuit fault has been rectified.
	Battery Detection Test Failed	The battery charger has failed to detect that a battery was connected to its output voltage terminals. When <i>Latching</i> is enabled, the alarm automatically clears when the battery voltage rises above the configured <i>Battery Detection Threshold</i> value. When <i>Auto Recovery</i> is enabled, the alarm automatically clears when the battery voltage rises above the <i>Battery Detection Threshold</i> value at the next scheduled <i>Battery Detection Test</i> .
	Battery Charger Failure	The battery charger has detected an internal failure. This alarm does not automatically reset, and the battery charger must be replaced or repaired.

4.2.3 ENGINEERING PAGES

Engineering pages give condensed easy to access information in two screens arranged as shown below. The instrument labels and data, where applicable, are abbreviated to limit the use of screen space and the meaning of these abbreviations are tabulated as follows.

4.2.3.1 ENGINEERING PAGE 1

OPV	26.4V	OPC	7.3A
OPVL	31.0V	OPCL	10.0A
OPPW	193W	BSV	26.2V
BTMP	40°C	MTMP	30°C

Abbreviation	Instrument
OPV	Output Voltage
OPC	Output Current
OPVL	Output Voltage Limit
OPCL	Output Current Limit
OPPW	Charger Output Power
BSV	Remote Battery Sense Voltage
BTMP	Battery Temperature
MTMP	Charger Temperature

4.2.3.2 ENGINEERING PAGE 2

ACSV	230V	ACSF	50.0Hz
CS	BCT	TR	56 m
TBT	0 m	TST	0 m
DIF	MB		

Abbreviation	Instrument	Display Format
ACSV	AC Supply Voltage	
ACSF	AC Supply Frequency	
CS	Charger State	Charger State (see <i>Display Abbreviations</i>)
TR	Charge State Time Remaining	
TBT	Time Until Next Battery Test	
TST	Time Until Next Self Test	
DIF	Digital Input Function	Digital Input Function (see <i>Display Abbreviations</i>)

4.2.3.2.1 DISPLAY ABBREVIATIONS

Digital Input Function

Abbreviation	Digital Input Function
EBD	Enable Battery Detection
LT	Lamp Test
MB	Manual Boost
MCMM	Max Current Mode (Manual)
MCMT	Max Current Mode (Timed)
SC	Stop Charging
SAVM	Switch to Alternative Voltage Mode

Charger State

Abbreviation	Charger State
START	Mode Startup
INIT	Mode Init
BOOST	Mode Boost
ABSORB	Mode Absorb
FLOAT	Mode Float
STORE	Mode Store
BCT	Mode Battery Connected Test
ERR1	Mode Error
ERR2	Mode Error 2
ERR3	Mode Error 3
LT	Mode Lamp Test
SC	Mode Stop Charging
CFT	Mode Charge Fail Test
CE	Mode Charger Error
KC	Mode Kill Charger
VD	Mode Voltage Detect
CT	Mode Charge Terminated
PSU	Mode PSU

5 OPERATION

The battery charger is usable as a battery charger, DC Power Supply Unit (PSU), or both at the same time. For instance, the battery charger can be used to power the control panel and charge the control panel's batteries or engine starter batteries at the same time.

When a suitable AC supply is connected and no fault is detected, the operation of the battery charger depends upon its configuration, and the load/batteries connected to its output terminals.

5.1 CHARGE FAIL RELAY

When the battery charger detects a fault that prevents it charging the battery, the *Charge Fail Relay* is de-energised. This is used to provide indication that the battery charger is no longer charging the battery due to an AC supply failure or a general battery charger shutdown alarm.

When the *Relay Active for Mains Alarms* option is disabled within the configuration, the relay will remain in its charging state until the *Deep Sleep Mode* becomes active. Under this condition the relay will reach a resting state in order to reduce the charger's current consumption by approximately a further 30 mA.

For further details about the available protection within the battery charger and how it operates, refer to section entitled *Protections* elsewhere in this document.

5.2 DIGITAL INPUT

NOTE: For further details of module configuration, refer to DSE Publication: 057-315 *DSEBC2410Ei Configuration Suite PC Software Manual*.

The Battery Charger is fitted with a configurable digital input. Configuration is made using the DSE Configuration Suite PC Software.

The default settings for the digital input provides a *Lamp Test* function.

5.3 PSU MODE

NOTE: For further details of module configuration, refer to DSE Publication: 057-238 *DSE BC2410Ei Configuration Suite PC Software Manual*.

If the battery is temporarily disconnected from the output terminals, the battery charger can operate as a DC power supply. When operating in this mode, the maximum output current is limited to the configured current limit value and the output voltage changes with the level of load.

If the battery charger is not charging batteries but is always operating as a Power Supply Unit (PSU) with a fixed output voltage then the *PSU Mode* is to be enabled.

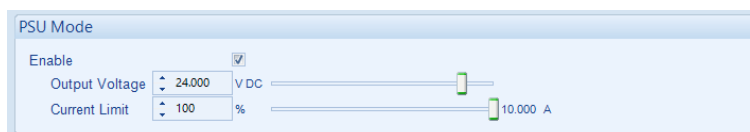

5.4 CHARGING MODE

 **NOTE: Ensure any standing load (loads connected to the battery charger other than the battery) are less than 75 % of the battery charger's configured current limit. This helps to ensure the charger correctly detects the battery's charge state.**

Constant Voltage & Current Limit

The battery charger operates in *Constant Voltage* and *Current Limited* mode.

The charger output voltage is maintained at a voltage level that varies depending on the battery charge state. This is done to allow the battery to charge while the load does not exceed the maximum rating of the charger.

If the load on the battery charger (charging current + standing load) exceeds the configured current limit, the charging current is limited to configured limit and the voltage is reduced if required.

The voltage rises to the required voltage level again once the total load drops below the configured current limit of the battery charger.

Charging Time

Charge time is often of little consequence when the battery is used in a *standby* operation. An example of this is when the battery is used to supply the starting system of a diesel generator. During normal operation, the battery is at full capacity and the battery charger is used to maintain the *Float Voltage* of the battery. The battery is only drained when the generator is called to start. As the generator has a DC charging alternator fitted, the battery is quickly recharged when the generator is running. Should the generator stop before the battery is fully recharged, the battery charger continues to recharge the battery until it is fully charged.

Typically, a battery charges from 0 % capacity to 80 % capacity in roughly 16 hours when charged at C/10. For example, charging a 50 Ah battery for 16 hours at 5 A (50 Ah / 10) charges the battery to 80 % of its full capacity.

Remember to consider any other standing load such as control panel requirements when calculating how much power is 'left' to charge the battery.

Once the battery is fully charged, the battery charger switches to an *ECO Power Mode* to reduce power consumption.

5.4.1 CHARGING PROFILE

NOTE: The battery charger is programmable to suit three or four stage charging profiles. For further details of module configuration, refer to DSE Publication: 057-329 *BC2410Ei Configuration Suite PC Software Manual*.

NOTE: If a two stage charging profile is required, select a three stage profile and configure *Boost Voltage* and *Float Voltage* to the same value.

The battery charging is configured to perform a three or four stage charging profile, selection between a three and four stage charging profile is based on battery type and application. A three stage charging profile contains a *Bulk*, *Absorption* and *Float* stage whereas a four stage charging profile contains a *Bulk*, *Absorption*, *Float* and *Storage* stage. It is also possible to add a *Charge Termination* stage to a three or four stage charging profile. The charging profile below shows the variation in output voltage between the stages.

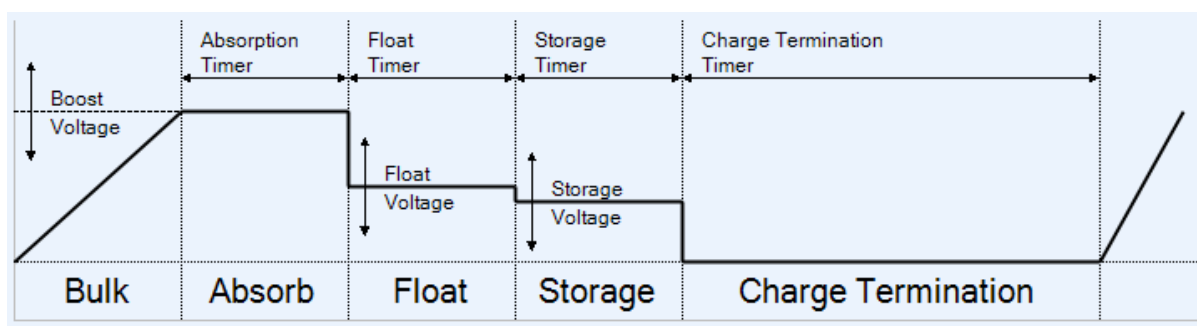

Bulk (Boost) Stage

The battery charger enters this mode at the beginning of the charge cycle or when the battery voltage drops below the configured *Bulk Trigger Voltage* level, indicating a discharged battery.

In this mode the battery charger operates in a *Boost Mode* and the load output rises to the configured *Boost Voltage*. If the load on the battery charger (charging current + standing load) exceeds the configured current limit, the charging current is limited to configured limit and the load output is reduced if required. The load output rises to the *Boost Voltage* level again once the total load drops below the configured current limit of the battery charger.

Absorption Stage

The battery charger enters this mode once the charger's output current falls below the configured *Bulk to Adoption Trigger Level*.

In this mode the battery charger load output falls to the configured *Absorption Voltage* and is maintained there for the duration of the *Absorption Timer*. During this time, the charge current continues to decrease.

Float Stage

The battery charger enters this mode once the *Absorption Timer* has expired.

In this mode the battery charger load output falls to the configured *Float Voltage* to prevent damage to the battery due to excessive gassing. Float Charge is used to provide a small amount of current to the battery to overcome internal losses and keep the battery at its 100% charged state.

Storage Stage

 **NOTE: *Storage Stage* is not applicable to three stage charging profiles.**

The battery charger enters this mode once the *Float Timer* has expired.

In this mode the battery charger output voltage falls to the configured *Storage Voltage* to minimise gassing and corrosion of the positive plates. Once a week, the battery charger output voltage is raised back to the *Absorption Voltage* for the *Absorption Timer* to equalize the battery cells. This feature prevents stratification of the electrolyte and sulphation, which is a major cause of early battery failure.

Charge Termination

 **NOTE: *Charge Termination* is a configurable option for three and four stage charging profiles, it is not enabled in the factory default settings. For further details of module configuration, refer to DSE Publication: 057-329 *DSE BC2410Ei Configuration Suite PC Software Manual*.**

The battery charger enters this mode once the charging current falls below the *Charge Termination Threshold*.

In this mode the battery charger output turns off for the duration of the *Charge Termination Timer*. The charger transfers back to the *Bulk (Boost) Stage* once the *Charge Termination Timer* expires, or the battery voltage drops below the *Bulk Trigger Voltage* level.

5.4.2 MANUAL BOOST OPERATION

Boost mode is activated manually using the battery charger's display, activating the battery charger's digital input when it is configured for *Manual Boost* or by MODBUS command. The battery charger's output voltage rises to the configured *Boost Voltage* until the output current falls below the configured *Bulk to Adoption Trigger Level*.

The battery charger enters *Boost Mode* again when the battery voltage drops below the configured *Bulk Trigger Voltage* level.

5.4.3 TEMPERATURE COMPENSATION

A temperature compensation function is available when the battery charger is operating in its *Float Stage*. The function is enabled in the battery charger's configuration and requires a 2 wire PT1000 temperature sensor to be connected to the battery and charger.

The temperature compensation causes the battery charger's output voltage to automatically vary by a configured mV per cell per 1°C deviation from 20°C, within the range of -20°C to 60°C. Increasing battery temperature decreases the battery charger's output voltage and vice versa.

**12 V Temperature Compensation Curves
at 3 mV / °C (Default Setting)**

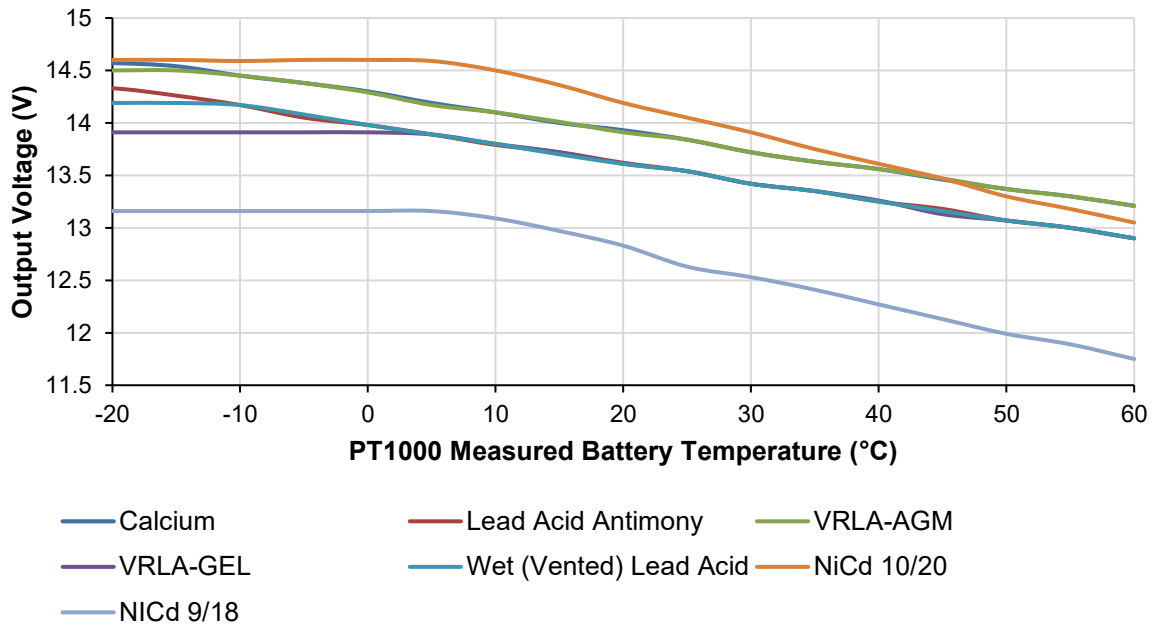



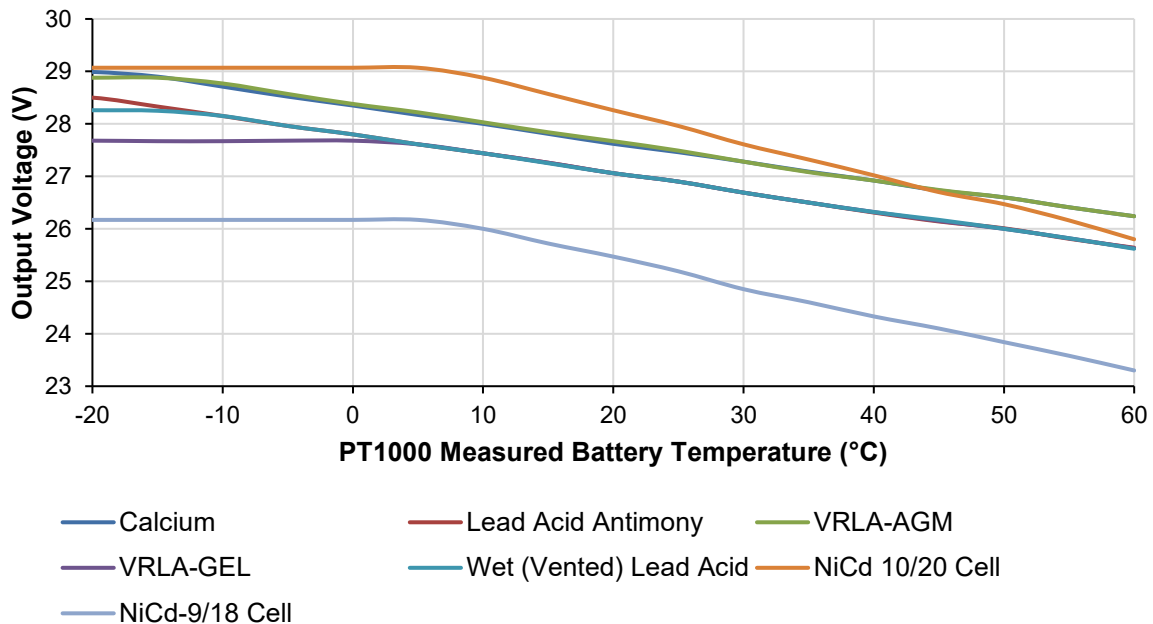



**24 V Temperature Compensation Curves
at 3 mV / °C (Default Setting)**



6 PROTECTIONS









6.1 WARNING ALARMS

Warning Alarms are pre-critical fault conditions and when active cause the battery charger's output voltage to fall to the configured *Float Voltage* level. The *Charge Failure Relay* does activate based on Warning Alarms. All Warning Alarms are self-resetting when the fault condition is removed or rectified.

Icon	Alarm	Description
	Battery Over Voltage	The battery charger has detected that the battery voltage has risen above the configured <i>Over Voltage Alarm</i> level for longer than the <i>Alarm Delay</i> . The alarm automatically clears once the battery voltage has fallen below the configured <i>Over Voltage Return</i> level for longer than the <i>Return Delay</i> .
	Battery Under Voltage	The battery charger has detected that the battery voltage has fallen below the configured <i>Under Voltage Alarm</i> level for longer than the <i>Alarm Delay</i> . The alarm automatically clears once the battery voltage has risen above the configured <i>Under Voltage Return</i> level for longer than the <i>Return Delay</i> .
	Charger Over Current	The battery charger has detected that its output current has risen above the configured <i>Over Current Alarm</i> level for longer than the <i>Alarm Delay</i> . The alarm automatically clears once the output current has fallen below the configured <i>Over Current Return</i> level for longer than the <i>Return Delay</i> .
	Mains Over Voltage	The battery charger has detected that the AC Supply has risen above the configured <i>Mains Over Voltage Alarm</i> level for longer than the <i>Alarm Delay</i> . The alarm automatically clears once the AC Supply has fallen below the configured <i>Mains Over Voltage Return</i> level for longer than the <i>Return Delay</i> .
	Mains Under Voltage	The battery charger has detected that the AC Supply has fallen below the configured <i>Mains Under Voltage Alarm</i> level for longer than the <i>Alarm Delay</i> . The alarm automatically clears once the AC Supply has risen above the configured <i>Mains Under Voltage Return</i> level for longer than the <i>Return Delay</i> .
	Battery Over Temperature	The battery charger has detected that the battery temperature has risen above the configured <i>Battery Temperature Warning Alarm</i> level for longer than the <i>Alarm Delay</i> . The alarm automatically clears once the battery temperature has fallen below the configured <i>Battery Temperature Warning Return</i> level for longer than the <i>Return Delay</i> .
	PTC Failure	The battery charger has detected that the PT1000 temperature sensor has failed (open/short circuit or above/below measurable range). The alarm automatically clears once a valid battery temperature is detected.

6.2 SHUTDOWN ALARMS

Shutdown Alarms are critical fault conditions that disable the battery charger's output and activates the *Charge Failure Relay*. Majority of the Shutdown Alarms are self-resetting when the fault condition is removed or rectified.

Icon	Alarm	Description
	Battery Over Voltage	The battery charger has detected that the battery voltage has risen above 32 V and has exceeded the operating specification. This alarm must be manually reset by disconnecting the battery charger. If the problem persists the battery charger must be replaced or repaired.
	Charger Over Current	The battery charger has detected that the output current has risen above 115 % of the configured current limit. This alarm must be manually reset by disconnecting the battery charger. If the problem persists the battery charger must be replaced or repaired.
	Mains Over Voltage	The battery charger has detected that the AC Supply voltage has risen above 310 V and has exceeded the operating specification. The alarm automatically clears once the AC Supply voltage has fallen below 305 V.
	Mains Under Voltage	The battery charger has detected that the AC Supply voltage has fallen below 90 V and has exceeded the operating specification. The alarm automatically clears once the AC Supply voltage has risen above 95 V.
	Battery Over Temperature	The battery charger has detected that the battery temperature has risen above the configured <i>Battery Temperature Shutdown Alarm</i> level. The alarm automatically clears once the battery temperature has fallen below the configured <i>Battery Temperature Shutdown Return</i> level.
	Charger Over Temperature	The battery charger has detected that the ambient temperature has risen above 81 °C and has exceeded the operating specification. The alarm automatically clears once the ambient temperature falls below 50 °C.
	Short Circuit or Reverse Polarity	The battery charger has detected that a battery was connected with a reverse polarity, or a short circuit has occurred to its output voltage terminals for longer then the configured <i>Delay</i> time. The alarm automatically clears once the reverse polarity or short circuit fault has been rectified.
	Battery Detection Test Failed	The battery charger has failed to detect that a battery was connected to its output voltage terminals. When <i>Latching</i> is enabled, the alarm automatically clears when the battery voltage rises above the configured <i>Battery Detection Threshold</i> value. When <i>Auto Recovery</i> is enabled, the alarm automatically clears when the battery voltage rises above the <i>Battery Detection Threshold</i> value at the next scheduled <i>Battery Detection Test</i> .
	Battery Charger Failure	The battery charger has detected an internal failure. This alarm does not automatically reset, and the battery charger must be replaced or repaired.

7 FRONT PANEL EDITOR

NOTE: More comprehensive configuration is possible via PC configuration software. For further details of module configuration, refer to DSE Publication: *057-238 DSE BC2410Ei Configuration Suite PC Software Manual*.

This configuration mode allows the operator to make minor configuration changes to the battery charger through its display without the use of the DSE Configuration Suite PC Software. Use the module's fascia buttons to navigate the menu and make value changes to the parameters:



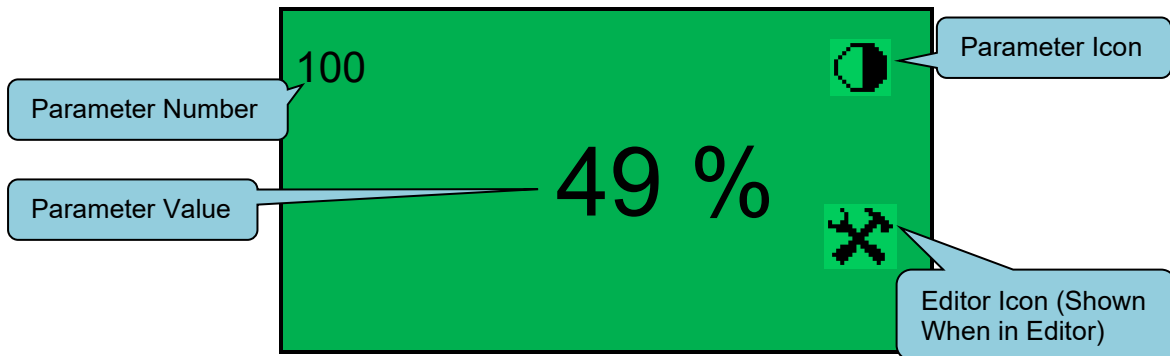

7.1 ACCESSING THE FRONT PANEL EDITOR

The front panel editor (FPE) is accessed by pressing and holding the  (✓) button for 10 seconds.





The first parameter is displayed...



7.1.1 SELECTING A PARAMETER

- Press  (+) or  (-) to change between parameter pages (listed overleaf).
- Press  (up) or  (down) to cycle through the available parameters (listed overleaf).

7.1.2 EDITING A PARAMETER











- Press  (✓) to edit a parameter when it is being viewed on the screen. The value flashes to show edit mode is in progress.
- Press  (+) or  (-) to change the parameter to the required value.
- Press  (✓) to save the currently selected value. The value ceases flashing to show editing is complete.

7.1.3 EXITING THE EDITOR

- Press and hold  (✓) to exit the editor.

7.2 FRONT PANEL EDITOR PARAMETERS

Each parameter is accompanied by an assigned index and icon. The description of these are tabulated below.

Index	Icon	Parameter	Description	Value
100		Contrast	Contrast setting for the LCD display.	0 %
101		Temperature Units	Temperature units for the charger display.	°C / °F
102		Backlight	Backlight setting for the LCD display. 0 to disable.	0 %
103		Backlight and LCD Power Save Timeout	Adjust the backlight and LCD power save mode timeout for the display. 0 to disable.	0, 10 s to 60 s
104		Enable Alarm Splash Screen	This will enable the splash screen for new alarms.	1 (On) / 0 (Off)
105		Page Timeout Screen	The screen to which the unit will revert (Home Page by default).	0 to 9 (Default Display Screen)
106		Page Timeout	Adjust the Summary screen timeout duration. 0 to disable.	0, 10 s to 60 s
107		Sleep Mode Timeout	Adjust the sleep mode timeout for the display. 0 to disable.	0, 10 s to 60 s
108		Enable/Disable Engineering Page	Enable/disable the engineering pages.	1 (On) / 0 (Off)
109		Deep Sleep Mode Timeout	Adjust the deep sleep mode timeout for the display. 0 to disable.	0, 120 s to 600 s

Default Display Screen

Parameter 105 – Page Timeout Screen selects the default display screen. This is the screen that is displayed after a period of inactivity (no buttons are pressed for the duration of *Page Timeout* (parameter 106). It has the following possible selections:

Value	Display Screen
0	Analogue Meters
1	Output Voltage and Current
2	Output Power and Battery Charger Temperature
3	Battery Sensed Voltage And Battery Temperature
4	Mains AC Voltage and Frequency
5	Battery Charger Model and Charger Software Version
6	Control Page
7	Alarms Page
8	Engineering Page 1
9	Engineering Page 2

8 MODBUS

The DSE Battery Charger supports the MODBUS RTU protocol over half-duplex RS485 communications.

RS485 Parameter	Setting
Start Bits	1
Data Bits	8
Parity	None
Stop Bits	2
Baud Rate	Configurable using DSE Configuration Suite PC Software (1200, 2400/ 4800, 9600, 19200, 28800, 38400, 57600, 115200) Factory Setting: 38400
MODBUS Server ID	Configurable using DSE Configuration Suite PC Software (1 to 247) Factory Setting: 10



8.1 READING VALUES

Values must be read using MODBUS *Function Code 3 – Read Multiple Registers*.

Using the DSE Configuration Suite PC Software, MODBUS registers are defined by the system designer in MODBUS Page 166.

An example of customer configuration is shown below, the screen image is taken from the DSE Configuration Suite PC Software.

Register	Value	Register	Value	Register	Value	Register	Value
0-1	Charge Output Off	64-65	<Not Used>	128-129	<Not Used>	192-193	<Not Used>
2-3	Fault LED	66-67	<Not Used>	130-131	<Not Used>	194-195	<Not Used>
4-5	Fault LED 2	68-69	<Not Used>	132-133	<Not Used>	196-197	<Not Used>
6-7	OPE Green LED	70-71	<Not Used>	134-135	<Not Used>	198-199	<Not Used>
8-9	OPE Yellow LED	72-73	<Not Used>	136-137	<Not Used>	200-201	<Not Used>
10-11	Relay Healthy	74-75	<Not Used>	138-139	<Not Used>	202-203	<Not Used>
12-13	Battery Temperature	76-77	<Not Used>	140-141	<Not Used>	204-205	<Not Used>
14-15	Output Voltage	78-79	<Not Used>	142-143	<Not Used>	206-207	<Not Used>
16-17	<Not Used>	80-81	<Not Used>	144-145	<Not Used>	208-209	<Not Used>

MODBUS Parameter	Value
MODBUS Register Start	<p> NOTE: Some Legacy MODBUS Client devices may require a suffix of 40,000 to the address, making the base address 82496.</p> <p> NOTE: Some MODBUS Client devices may require '1' to be added to the address.</p> <p>Address Page 166 Absolute HexaDecimal Address A600 Absolute Decimal Address 42496 (166 x 256).</p>
MODBUS Register Size / Sign	32 bit, signed
MODBUS Register Type	Holding Registers (MODBUS function code 3 supported)

8.2 WRITING VALUES

Writing values to the battery charger is used to perform functions below. Two values must be written using the same write function.

Using MODBUS *Function Code 16 – Write Multiple Registers*, write the required Control Key and One's Compliment of the Control key to the specified registers:

8.2.1 TOGGLE BOOST MODE

Writing this control key enables or disables boost mode. When in boost mode, the battery is charged at the configured *boost voltage*.

Single MODBUS Write using MODBUS *Function Code 16 – Write Multiple Registers*.

Address	Control Key	One's Compliment of Control Key
Decimal Address 4104 & 4105 (Hexadecimal 1008 & 1009)	35772	27963

8.2.2 TOGGLE CHARGER ON/OFF

Writing this control key enables or disables the charger's DC output.

Single MODBUS Write using MODBUS *Function Code 16 – Write Multiple Registers*.

Address	Control Key	One's Compliment of Control Key
Decimal Address 4104 & 4105 (Hexadecimal 1008 & 1009)	35773	29762

9 FAULT DIAGNOSIS

Problem	Suggestion
The charger is not operating	<p>Check if Auto Voltage Detection is enabled. If so the battery charger does not output a voltage until it is detected to a battery to confirm if it is a 12 V or 24 V application.</p> <p>Check that the incoming AC supply is correctly connected and within limits and check the integrity of any external fuse that may be fitted.</p> <p>Ensure the charger is not being operated above the maximum temperature specification.</p>
Charge fail relay continuously operated	Check the connected load of the charger is not reverse connected or short circuit.
Batteries fail to charge	Check the batteries using the battery manufacturers recommendations.
Charge time is too long	<p>Typically, a battery will charge from flat to 80% capacity in 16 hours when charged at C/10.</p> <p>For example, charging a 50 Ah battery for 16 hours at 5 A charges the battery to 80% of its full capacity.</p> <p>Remember to consider any other standing load such as control panel requirements when calculating how much power is 'left' to charge the battery.</p>

10 EFFICIENCY CALCULATIONS

The power dissipation, power consumption and power factor of a device are often required during the design process of an application. These values are calculated using the following equations and values listed in the section entitled *Specification* found elsewhere in this document.

10.1 MAXIMUM POWER DISSIPATION

$$P_{DC} = V_{DC} \times I_{DC}$$

$$P_{Loss} = P_{DC} \times \left(\frac{100 - \eta}{100} \right)$$

Where:

V_{DC} = Maximum configured DC voltage in battery profile

I_{DC} = Configured DC current limit

P_{DC} = Calculated maximum DC power generation

η = Battery charger efficiency at supply AC voltage (V_{AC})

P_{Loss} = Calculated Dissipated Power

10.2 MAXIMUM POWER CONSUMPTION

$$P_{DC} = V_{DC} \times I_{DC}$$

$$P_{AC} = P_{DC} \times \left(\frac{100}{\eta} \right)$$

Where:

V_{DC} = Maximum configured DC voltage in battery profile

I_{DC} = Configured DC current limit

P_{DC} = Calculated maximum DC power generation

η = Battery charger efficiency at supply AC voltage (V_{AC})

P_{AC} = Calculated AC power consumption

10.3 POWER FACTOR AT MAXIMUM POWER

$$S_{AC} = V_{AC} \times I_{AC}$$

$$pf = \frac{P_{AC}}{S_{AC}}$$

Where:

V_{AC} = Supply AC voltage

I_{AC} = Maximum battery charger current draw at maximum load

S_{AC} = Calculated apparent power

P_{AC} = Calculated AC power consumption

pf = Calculated power factor at full load

11 MAINTENANCE, SPARES, REPAIR AND SERVICING

The DSE battery chargers are designed to be *Fit and Forget*. As such, there are no user serviceable parts. In the case of malfunction, contact the Original Equipment Supplier (OEM).

12 WARRANTY

DSE provides limited warranty to the equipment purchaser at the point of sale. For full details of any applicable warranty, you are referred to your original equipment supplier (OEM).

13 DISPOSAL

13.1 WEEE (WASTE ELECTRICAL AND ELECTRONIC EQUIPMENT)

If you use electrical and electronic equipment you must store, collect, treat, recycle and dispose of WEEE separately from your other waste.



Page is Left Intentionally Blank