



DEEP SEA ELECTRONICS

DSEG8680 Configuration Suite

PC Software Manual

Document Number: 057-326

Author: Ian Roberts





Deep Sea Electronics Ltd.

Highfield House
Hunmanby
North Yorkshire
YO14 0PH
England

Sales Tel: +44 (0) 1723 890099

E-mail: sales@deepseaelectronics.com

Website: www.deepseaelectronics.com

DSEG8680 Configuration Suite PC Software Manual

© Deep Sea Electronics Ltd.

All rights reserved. No part of this publication may be reproduced in any material form (including photocopying or storing in any medium by electronic means or other) without the written permission of the copyright holder except in accordance with the provisions of the Copyright, Designs and Patents Act 1988.

Applications for the copyright holder's written permission to reproduce any part of this publication must be addressed to Deep Sea Electronics Ltd. at the address above.

The DSE logo and the names DSEGenset®, DSEATS®, DSEPower® and DSEControl® are UK registered trademarks of Deep Sea Electronics Ltd.

Any reference to trademarked product names used within this publication is owned by their respective companies.

Deep Sea Electronics Ltd. reserves the right to change the contents of this document without prior notice.

Amendments Since Last Publication

Amd. No.	Config Suite Version No	Comments	Date
1	1.0	Initial release	13/04/2023

Typeface: The typeface used in this document is *Arial*. Care must be taken not to mistake the upper-case letter I with the numeral 1. The numeral 1 has a top serif to avoid this confusion.

TABLE OF CONTENTS

Section	Page
1 INTRODUCTION.....	5
1.1 CLARIFICATION OF NOTATION.....	6
1.2 GLOSSARY OF TERMS.....	6
1.3 BIBLIOGRAPHY	8
1.3.1 INSTALLATION INSTRUCTIONS.....	8
1.3.2 MANUALS	9
1.3.3 TRAINING GUIDES	10
1.3.4 THIRD PARTY DOCUMENTS	11
1.4 INSTALLATION AND USING THE DSE CONFIGURATION SUITE SOFTWARE	11
2 GENERAL CONTROLS.....	12
2.1 USER CONTROLS.....	12
3 EDITING THE CONFIGURATION	14
3.2 APPLICATION	15
3.3 MODULE	16
3.3.2 DISPLAY CONFIGURATION.....	19
3.3.3 EVENT LOG	22
3.3.4 DATA LOGGING	23
3.4 DIGITAL INPUTS	26
3.4.1 DIGITAL INPUT FUNCTIONS.....	28
3.5 OUTPUTS.....	30
3.5.1 DIGITAL OUTPUTS	30
3.5.2 VIRTUAL LEADS	31
3.5.3 OUTPUT SOURCES.....	32
3.6 TIMERS	38
3.6.1 LOAD TIMERS	38
3.6.2 MODULE TIMERS	38
3.7 BUS.....	39
3.7.1 BUS OPTIONS	39
3.7.2 BUS CURRENT.....	43
3.7.3 POWER	58
3.7.4 BUS VOLTAGE	61
3.7.5 BUS FREQUENCY	63
3.7.6 FREQUENCY THRESHOLDS	63
3.7.7 LEFT BUS FREQUENCY THRESHOLDS	63
3.7.8 RIGHT BUS FREQUENCY THRESHOLDS	64
3.8 SYSTEM.....	65
3.8.1 PLANT BATTERY	65
3.9 COMMUNICATIONS	66
3.9.1 COMMUNICATION OPTIONS.....	66
3.9.2 RS485 PORT.....	67
3.10 ETHERNET PORT.....	68
3.11 ALTERNATIVE CONFIGURATIONS.....	70
3.11.1 ALTERNATIVE CONFIGURATION OPTIONS	70
3.11.2 ALTERNATIVE CONFIGURATION 1 TO 5	71
3.12 EXPANSION.....	73
3.12.1 DSE2130 INPUT MODULES	74
3.12.2 DSE2131 INPUT MODULES	81
3.12.3 DSE2133 INPUT MODULES	88
3.12.4 DSE2152 OUTPUT MODULES	92
3.12.5 DSE2157 RELAY MODULES	96
3.12.6 DSE2548 ANNUNCIATOR MODULES.....	97
3.12.7 BATTERY CHARGERS	100
3.13 ADVANCED.....	102
3.13.1 ADVANCED OPTIONS	102

3.13.2	PLC.....	103
3.13.3	CONFIGURABLE GENCOMM PAGES 166 TO 169.....	104
4	SCADA	106
4.1	SYSTEM IDENTITY.....	107
4.2	MIMIC	107
4.3	DIGITAL INPUTS	108
4.4	DIGITAL OUTPUTS	109
4.5	VIRTUAL LEDES.....	110
4.6	POWER	111
4.7	LEFT BUS	112
4.7.1	FREQUENCY AND VOLTAGES.....	112
4.7.2	LOAD.....	113
4.7.3	SYNC.....	113
4.8	RIGHT BUS	114
4.8.1	FREQUENCY AND VOLTAGES.....	114
4.8.2	LOAD.....	115
4.8.3	SYNC.....	115
4.9	AMSC LINK.....	116
4.10	ALARMS.....	117
4.11	STATUS.....	118
4.12	EVENT LOG	119
4.13	REMOTE CONTROL.....	120
4.14	MAINTENANCE.....	120
4.14.1	EXPANSION CALIBRATION	121
4.14.2	DATE AND TIME.....	121
4.14.3	MODULE PIN	122
4.15	COMMUNICATIONS INFORMATION.....	123
4.16	DATA LOG	124
4.17	EXPANSION.....	126
5	ALARM TYPES.....	127
6	ALARM ARMING.....	127
6.1	NEVER	127
6.2	ALWAYS	127

1 INTRODUCTION

This document details the use of the *DSE Configuration Suite PC Software* with the DSEG8680 module, which is part of the DSE **GenSet**® range of products.

The manual forms part of the product and should be kept for the entire life of the product. If the product is passed or supplied to another party, ensure that this document is passed to them for reference purposes.

This is not a *controlled document*. DSE do not automatically inform on updates. Any future updates of this document are included on the DSE website at www.deepseaelectronics.com



The *DSE Configuration Suite PC Software* allows the DSEG8680 module to be connected to a PC via USB A to USB B cable (USB printer cable). Once connected, the software allows easy, controlled access to various operating parameters within the module which can then be viewed and edited as required.

The *DSE Configuration Suite PC Software* must only be used by competent, qualified personnel, as changes to the operation of the module may have safety implications on the panel / generating set to which it is fitted. Access to critical operational sequences and settings for use by qualified engineers, may be barred by a security code set by the generator provider.

The information contained in this manual must be read in conjunction with the information contained in the appropriate module documentation. This manual only details which settings are available and how they may be used. Separate manuals deal with the operation of the individual module and its ancillaries, refer to section 1.3 entitled *Bibliography* in this document for further information.

1.1 CLARIFICATION OF NOTATION

Clarification of notation used within this publication.

 NOTE:	Highlights an essential element of a procedure to ensure correctness.
 CAUTION!	Indicates a procedure or practice, which, if not strictly observed, could result in damage or destruction of equipment.
 WARNING!	Indicates a procedure or practice, which could result in injury to personnel or loss of life if not followed correctly.

1.2 GLOSSARY OF TERMS

Term	Description
AMSC	Advanced Multi-Set Communication
AVR	Automatic Voltage Regulator
BMS	Building Management System. A digital/computer based control system for a building's infrastructure.
BUS	BUS is a communication system that transfers data between components inside a computer, or between computers.
CAN	Controller Area Network. Vehicle standard to allow digital devices to communicate to one another.
CDMA	Code Division Multiple Access. Cell phone access used in small number of areas including parts of the USA and Australia.
DEF	Diesel Exhaust Fluid (AdBlue).A liquid used as a consumable in the SCR process to lower nitric oxide and nitrogen dioxide concentration in engine exhaust emissions.
DHCP	DHCP (Dynamic Host Configuration Protocol) is a protocol that provides quick, automatic, and central management for the distribution of IP addresses within a network.
DNS	Domain Name System is a collection of databases that translate hostnames to IP addresses.
DPF	Diesel Particulate Filter. A filter fitted to the exhaust of an engine to remove diesel particulate matter or soot from the exhaust gas.
DPTC	Diesel Particulate Temperature Controlled Filter. A filter fitted to the exhaust of an engine to remove diesel particulate matter or soot from the exhaust gas which is temperature controlled.
DTC	Diagnostic Trouble Code. The name for the entire fault code sent by an engine ECU.
ECU/ECM	Engine Control Unit/Management. An electronic device that monitors engine parameters and regulates the fuelling.
FMI	Failure Mode Indicator. A part of DTC that indicates the type of failure, e.g. high, low, open circuit etc.
FPE	Front Panel Editor
FRT	Fault Ride Through
GPRS	General Packet Radio Service
GSM	Global System for Mobile communications. Cell phone technology used in most of the World.
HEST	High Exhaust System Temperature. Initiates when DPF filter is full in conjunction with an extra fuel injector in the exhaust system to burn off accumulated diesel particulate matter or soot.
HMI	Human Machine Interface. A device that provides a control and visualisation interface between a human and a process or machine.
IDMT	Inverse Definite Minimum Time
IEEE	Institute of Electrical and Electronics Engineers

Introduction

Term	Description
ISBN	International Standard Bibliographic Description
LAN	Local Area Network
LCD	Liquid Crystal Display
LED	Light Emitting Diode
LSB	Least Significant Bit
MPU	Magnetic Pickup Unit
MSB	Most Significant Bit
NAPT	Network Address and Port Translation
NVD	Neutral Voltage Displacement
OEM	Original Equipment Manufacturer
PGN	Parameter Group Number. A CANbus address for a set of parameters that relate to the same topic and share the same transmission rate.
PID	Gain (P), Stability (I) and Derivative (D) settings of the engine's governor
PIN	PIN number
PLC	Programmable Logic Controller. A programmable digital device used to create logic for a specific purpose.
RPM	Revolutions Per Minute
RTD	An RTD (Resistance Temperature Detector) is a sensor whose resistance changes as its temperature changes. The resistance increases as the temperature of the sensor increases.
SCADA	Supervisory Control And Data Acquisition. A system that operates with coded signals over communication channels to provide control and monitoring of remote equipment
SCR	Selective Catalytic Reduction. A process that uses DEF with the aid of a catalyst to convert nitric oxide and nitrogen dioxide into nitrogen and water to reduce engine exhaust emission.
SIM	Subscriber Identity Module. The small card supplied by the GSM/CDMA provider that is inserted into the cell phone, GSM modem or DSEGateway device to give GSM/GPRS connection.
SMS	Short Message Service. The text messaging service of mobile/cell phones.
SNMP	Simple Network Management Protocol. An international standard protocol for managing devices on IP networks.
SPN	Suspect Parameter Number. A part of DTC that indicates what the failure is, e.g. oil pressure, coolant temperature, turbo pressure etc.
TCP	TCP (Transmission Control Protocol) is a standard that defines how to establish and maintain a network conversation via which application programs can exchange data.
USB	Universal Serial Bus
WAN	Wide Area Network

1.3 BIBLIOGRAPHY

This document refers to, and is referred by the following DSE publications which are obtained from the DSE website: www.deepseaelectronics.com or by contacting DSE technical support: support@deepseaelectronics.com.

1.3.1 INSTALLATION INSTRUCTIONS

Installation instructions are obtained from the DSE website: www.deepseaelectronics.com or by contacting DSE technical support: support@deepseaelectronic.com and are intended as a 'quick start' guide only.

DSE Part	Description
053-032	DSE2548 LED Expansion Annunciator Installation Instructions
053-033	DSE2130 Input Expansion Installation Instructions
053-034	DSE2157 Output Expansion Installation Instructions
053-049	DSE9xxx Battery Charger Installation Instructions
053-125	DSE2131 Ratio-metric Input Expansion Installation Instructions
053-126	DSE2133 RTD/Thermocouple Input Expansion Installation Instructions
053-134	DSE2152 Ratio-metric Output Expansion Installation Instructions
053-147	DSE9460 & DSE9461 Battery Charger Installation Instructions
053-185	DSE9473 & DSE9483 Battery Charger Installation Instructions
053-254	DSEG8680 Installation Instructions

1.3.2 MANUALS

Product manuals are obtained from the DSE website: www.deepseaelectronics.com or by contacting DSE technical support: support@deepseaelectronics.com.

DSE Part	Description
057-004	Electronic Engines and DSE Wiring Guide
057-045	Guide to Synchronising and Load Sharing Part 1 (Usage of DSE Load Share Controllers in synchronisation / load sharing systems.)
057-046	Guide to Synchronising and Load Sharing Part 2 (Governor & AVR Interfacing)
057-047	Load Share System Design and Commissioning Guide
057-082	DSE2130 Input Expansion Operator Manual
057-083	DSE2157 Output Expansion Operator Manual
057-084	DSE2548 Annunciator Expansion Operator Manual
057-085	DSE9xxx Battery Charger Operator Manual
057-139	DSE2131 Ratio-metric Input Expansion Manual
057-140	DSE2133 RTD/Thermocouple Expansion Manual
057-141	DSE2152 Ratio-metric Output Expansion Manual
057-151	DSE Configuration Suite PC Software Installation & Operation Manual
057-175	PLC Programming Guide For DSE Controllers
057-176	DSE9460 & DSE9461 Battery Charger Operator Manual
057-312	DSEAssistant PC Software Manual
057-314	Advanced PLC Software Manual
057-327	DSEG8680 Operator Manual
057-350	DSEG0123 AMSC Operator Manual

1.3.3 TRAINING GUIDES

Training guides are provided as 'hand-out' sheets on specific subjects during training sessions and contain specific information regarding to that subject.

DSE Part	Description
056-001	Four Steps To Synchronising
056-005	Using CTs With DSE Products
056-006	Introduction to Comms
056-010	Over Current Protection
056-013	Load Demand Scheme
056-018	Negative Phase Sequence
056-019	Earth Fault Protection
056-020	Loss Of Excitation
056-021	Mains Decoupling
056-022	Switchgear Control
056-023	Adding New CAN Files
056-024	GSM Modem
056-026	kVA, kW, kvar and Power Factor
056-029	Smoke Limiting
056-030	Module PIN Codes
056-033	Synchronising Requirements
056-036	DSE Module Expansion
056-043	Sync Process
056-045	PLC as Load Demand Controller
056-047	Out of Sync and Failed To Close
056-051	Modbus Control
056-053	Recommended Modems
056-055	Alternate Configurations
056-057	SW1 & SW2
056-069	Firmware Update
056-072	Dead Bus Synchronising
056-075	Adding Language Files
056-076	Gencomm Alarms
056-079	Gencomm Status
056-080	Modbus
056-081	Screen Heaters
056-082	Override Gencomm PLC Example
056-084	Synchronising & Loadsharing
056-086	G59
056-091	Equipotential Earth Bonding
056-092	Best Practices for Wiring Restive Sensors
056-094	AMSC Compatibility
056-095	Remote Start Input Functions
056-097	USB Earth Loops and Isolation
056-099	Digital Output to Digital Input Connection
056-118	Configurable CAN
056-123	Simulation Injection Testing

1.3.4 THIRD PARTY DOCUMENTS

The following third-party documents are also referred to:

Reference	Description
ISBN 1-55937-879-4	IEEE Std C37.2-1996 IEEE Standard Electrical Power System Device Function Numbers and Contact Designations. Institute of Electrical and Electronics Engineers Inc
ISBN 0-7506-1147-2	Diesel generator handbook. L.L.J. Mahon
ISBN 0-9625949-3-8	On-Site Power Generation. EGSA Education Committee.

1.4 INSTALLATION AND USING THE DSE CONFIGURATION SUITE SOFTWARE

For information regarding installing and using the *DSE Configuration Suite PC Software*, refer to DSE publication: **057-151 DSE Configuration Suite PC Software Installation & Operation Manual** which is found on the DSE website: www.deepseaelectronics.com

2 GENERAL CONTROLS

NOTE: For information on Menu & Toolbars please refer to DSE Publication: 057-151 *DSE Configuration Suite PC Software Installation & Operation Manual*

Overview

The *DSE Configuration Suite PC Software* dialog boxes provide the user with a way to type text, choose options, and initiate actions. Controls in other windows provide a variety of services, such as letting the user choose commands and view and edit text. This section describes the controls provided by the *DSE Configuration Suite* and how to manipulate them. The diagram below shows the general controls of the main configuration screen.

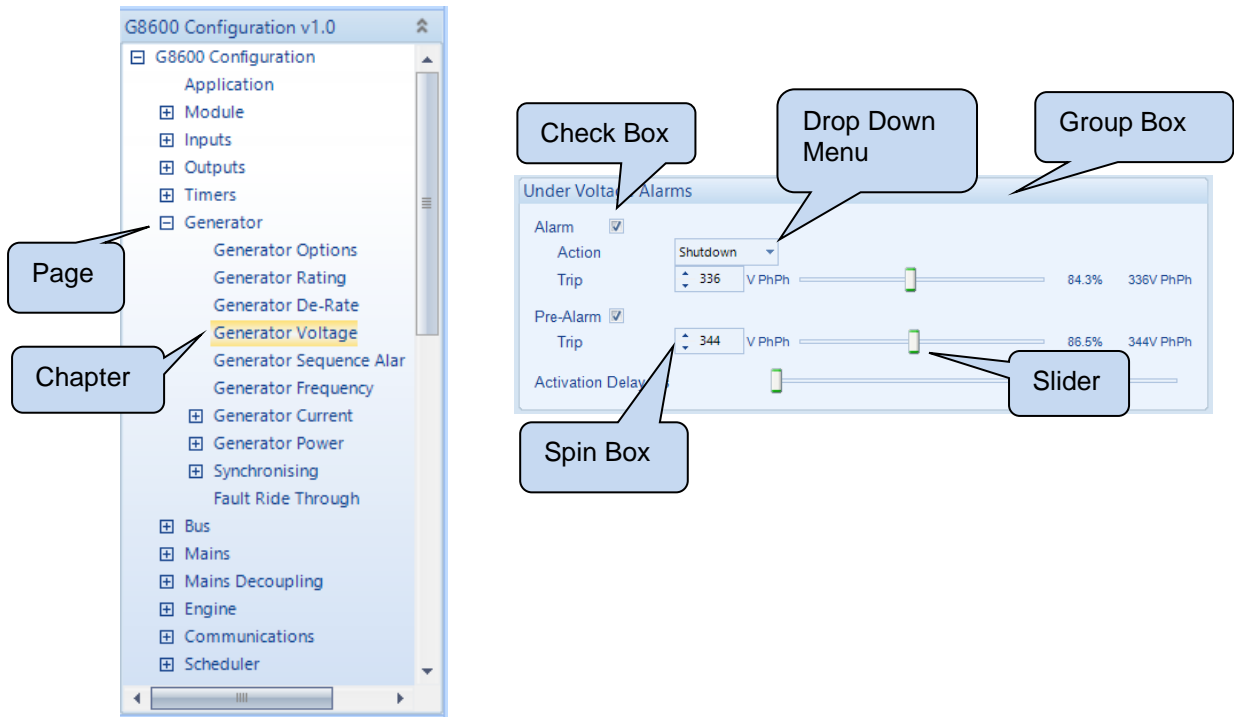

2.1 USER CONTROLS

Slider

The Slider Control allows the user to change a value using a mouse or arrows found on a standard keyboard.

The slider is highlighted in green in its inactive state and will change to orange (active state) once selected by a mouse pointer.



Inactive state

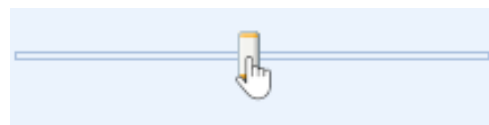

Active state

During the active state, the slider is moved with the mouse pointer and the left and right keyboard arrows.

Spin Box

The Spin box displays the current value of the setting in the group box.

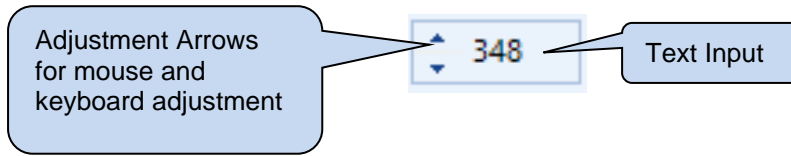

Clicking the mouse over the Spin box will change its colour to orange putting it in an active state.



During the active state text is entered using the keyboard, changed using the mouse pointer or the up and down arrows on the keyboard.

Check box



Used to select a parameter

Drop down menu

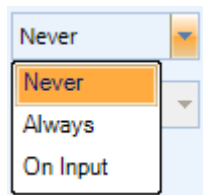

Used to select an action

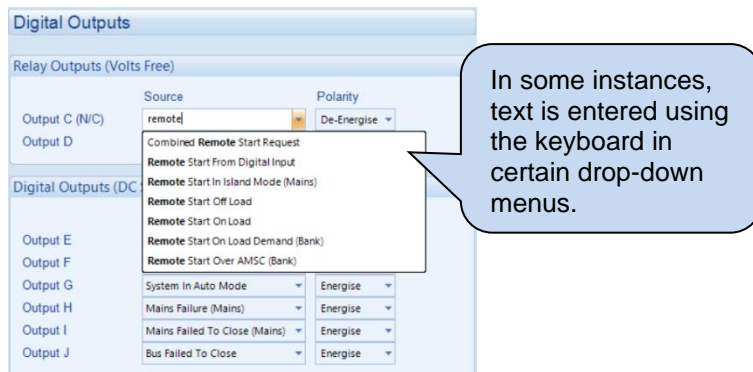

Used to select a source

3 EDITING THE CONFIGURATION

This menu allows module configuration, to change the function of Inputs, Outputs and LED's, system timers and level settings to suit a particular application.

NOTE: Available drop-down menus will depend on other options that are selected throughout the software.

NOTE: The SCADA sections will appear depending on how the module is configured.

3.1 SCREEN LAYOUT

Step forward or backward through previously viewed pages

The type of configuration file being edited

The coloured shading shows the currently selected page.

Click + or - to show or hide the sub settings within each section.

Move to the Previous or Next configuration page

Close this configuration file

Click to select the subsection to view / edit

Click to return to the Home section shown

Click to step Forward or Back through previously viewed configuration sections

Click to view / edit the section

3.2 APPLICATION

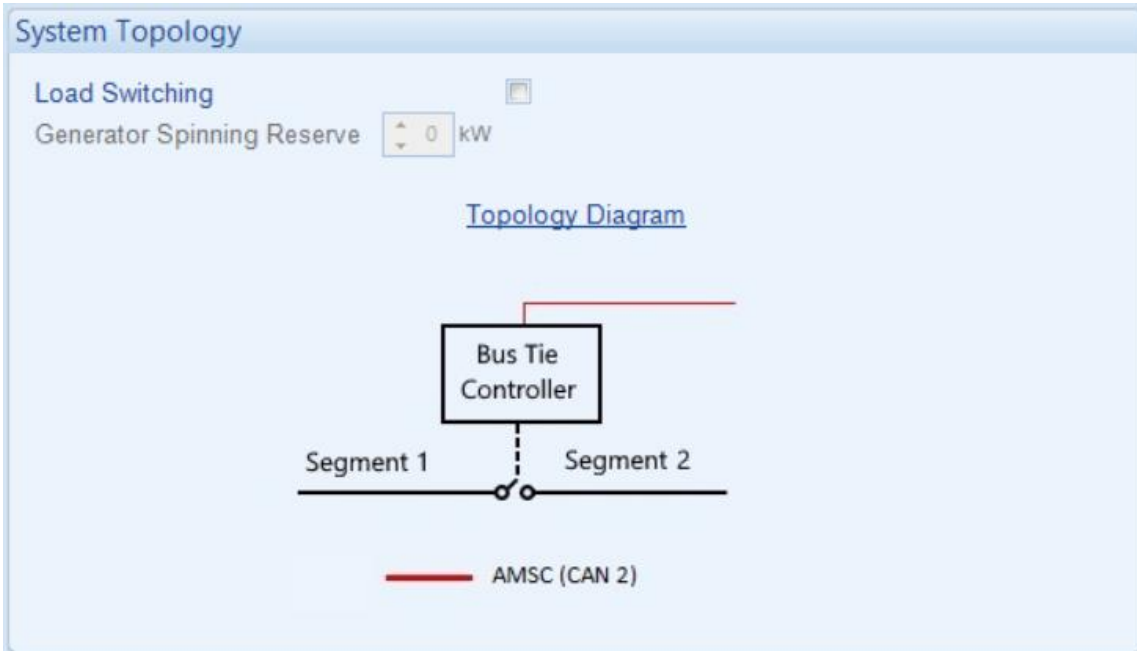

Parameter	Description
Load Switching	<p><input type="checkbox"/> = Load Switching is disabled. <input checked="" type="checkbox"/> = Load Switching is enabled.</p> <p>The screenshot shows the 'System Topology' configuration window. 'Load Switching' is now enabled (checkbox is checked) and 'Generator Spinning Reserve' is set to 1 kW. The 'Topology Diagram' shows the 'Bus Tie Controller' connected to a single 'Segment' via a switch. The red line for 'AMSC (CAN 2)' remains.</p>
Generator Spinning Reserve	The spinning reserve required to close the load switch.

3.3 MODULE

The module page is subdivided into smaller sections.
Select the required section with the mouse.

This section allows the user to change the options related to the module itself.

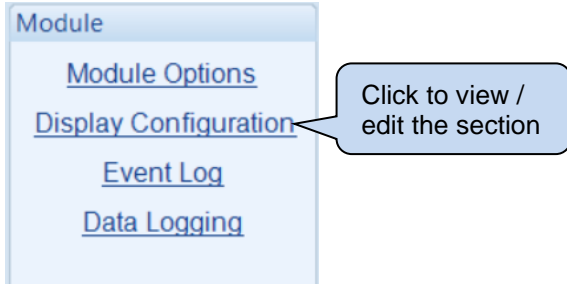

3.3.1 MODULE OPTIONS

Description

Parameter	Description
Description	<p>Four free entry boxes to allow the user to give the configuration file a description. Typically used to enter the job number, customer name, engine information etc.</p> <p>This text is not shown on the module's display and is only seen in the configuration file.</p>

LED Indicators

Parameter	Description
Functions 1-4	<p>Allows the user to select the function of the module's user configurable LED indicators.</p> <p>For details of selections, please see section 3.5.3 entitled <i>Output sources</i></p> <p>Available indicator options are:</p> <p>Lit: The LED indicator is lit Unlit: The Led indicator is unlit</p>
Insert Card Text	Allows the user to create logo and text insert cards.
Text Insert	<p>Only available when currently viewing the <i>Module</i> section of the configuration.</p> <p>This allows the user to create Text Inserts for the configurable LEDs on the certain DSE modules.</p>
Logo Insert	<p>Only available when currently viewing the <i>Module</i> section of the configuration.</p> <p>This allows the user to create Logo Inserts for certain DSE modules to customise the controller to suit the generator manufacturer.</p>

Miscellaneous Options

Various Module options are configurable on this page.

Miscellaneous Options	
All Warnings are Latched	<input type="checkbox"/>
Support Right-To-Left Languages in Module Strings	<input type="checkbox"/>

Parameter	Description
All Warnings Are Latched	<input type="checkbox"/> = Normal Operation, the warnings and pre-alarms will automatically reset once the triggering condition has cleared. <input checked="" type="checkbox"/> = Warnings and pre-alarms latch when triggered. Resetting the alarm is performed by either an external reset applied to one of the inputs or, the 'Stop/Reset' pushbutton must be operated (once the triggering condition has been cleared).
Support Right-To-Left Languages in Module Strings	Determines the direction of text input where supported (i.e., configurable input text) <input type="checkbox"/> =Left To Right language support <input checked="" type="checkbox"/> =Right To Left language support

Power Saving Options

The modules backlight is switched off after the *Backlight Power Save Mode Delay* setting in the *Interface Timers* section, has expired if no buttons are pressed.

Power Saving Options	
Enable Backlight Power Saving Mode	<input type="checkbox"/>

Parameter	Description
Enable Backlight Power Saving Mode	<input type="checkbox"/> = The <i>Backlight Power Saving Mode</i> is disabled. <input checked="" type="checkbox"/> = The <i>Backlight Power Saving Mode</i> is enabled.

3.3.2 DISPLAY CONFIGURATION

Displayed Pages

Displayed Pages			
Page 1	Not Used	Page 6	Not Used
Page 2	Not Used	Page 7	Not Used
Page 3	Not Used	Page 8	Not Used
Page 4	Not Used	Page 9	Not Used
Page 5	Not Used	Page 10	Not Used

Parameter	Description
Page 1-10	<p>These instruments are displayed one after the other when the set runs. If an entry is set to 'Not Used,' or is not applicable, the entry is skipped over and not displayed.</p> <p>The pages available are shown in the list below:</p> <ul style="list-style-type: none"> • Battery Voltage • Bus Current • Bus Power • Left AMSC Power • Left Bus- Bus Tie Controllers Connected • Left Bus- Mains Controllers Connected • Left Bus Frequency • Left Bus Phase Rotation • Left Bus Sets On AMSC Bus • Left Bus Sets On Load • Left Bus Voltage L-L • Left Bus Voltage L-N • Right AMSC Power • Right Bus- Bus Tie Controllers Connected • Right Bus- Mains Controllers Connected • Right Bus Frequency • Right Bus Phase Rotation • Right Bus Sets On AMSC Bus • Right Bus Sets On Load • Right Bus Voltage L-L • Right Bus Voltage L-N • Synchroscope

Instrumentation Suppression (CT Fitted Only)

Instrumentation Suppression (CT Fitted Only)

Suppress the following instrumentation on the module screen

Voltage	<input type="checkbox"/>
Current	<input type="checkbox"/>
kW	<input type="checkbox"/>
kVAr	<input type="checkbox"/>
kVA	<input type="checkbox"/>

Parameter	Description
Suppress the following instrumentation on the module screen	<p>Allows suppression of the available instrumentation that is derived from the CT inputs.</p> <p><input type="checkbox"/> = Instrumentation suppression is disabled <input checked="" type="checkbox"/> = Instrumentation suppression is enabled</p>

Instrumentation Suppression (AMSC)

Instrumentation Suppression (AMSC)

Suppress the following instrumentation on the module screen

Left Bus Voltage	<input type="checkbox"/>	Right Bus Voltage	<input type="checkbox"/>
Left Bus kW	<input type="checkbox"/>	Right Bus kW	<input type="checkbox"/>
Left Bus kVAr	<input type="checkbox"/>	Right Bus kVAr	<input type="checkbox"/>

Parameter	Description
Suppress the following instrumentation on the module screen	<p>Allows suppression of the available instrumentation that is received from the AMSC bus, not derived from the CT inputs.</p> <p><input type="checkbox"/> = Instrumentation suppression is disabled <input checked="" type="checkbox"/> = Instrumentation suppression is enabled</p>

3.3.3 EVENT LOG

The event log is configured to allow users to select which events are stored.

Logged Events

Log the following events to the event log

Power-Up <input checked="" type="checkbox"/>	Bus Off Load <input checked="" type="checkbox"/>
Electrical Trip Alarms <input checked="" type="checkbox"/>	Bus On Load <input checked="" type="checkbox"/>
Latched warnings <input checked="" type="checkbox"/>	
Unlatched warnings <input checked="" type="checkbox"/>	

Parameter	Description
Power-Up	<input type="checkbox"/> = <i>Power-Up</i> events are not logged. <input checked="" type="checkbox"/> = <i>Power-Up</i> events are logged when the DC Supply is applied to the module.
Electrical Trip Alarms	<input type="checkbox"/> = <i>Electrical Trip Alarms</i> are not logged. <input checked="" type="checkbox"/> = <i>Electrical Trip Alarms</i> are logged when the moment they activate.
Latched Warnings	<input type="checkbox"/> = <i>Latched Warnings Alarms</i> are not logged. <input checked="" type="checkbox"/> = <i>Latched Warnings Alarms</i> are logged when the moment they activate.
Unlatched Warnings	<input type="checkbox"/> = <i>Unlatched Warnings Alarms</i> are not logged. <input checked="" type="checkbox"/> = <i>Unlatched Warnings Alarms</i> are logged when the moment they activate.
Bus Off Load	<input type="checkbox"/> = <i>Bus Off Load Events</i> are not logged. <input checked="" type="checkbox"/> = <i>Bus Off Load Events</i> are logged when the moment they activate.
Bus On Load	<input type="checkbox"/> = <i>Bus On Load Events</i> are not logged. <input checked="" type="checkbox"/> = <i>Bus On Load Events</i> are logged when the moment they activate.

3.3.4 DATA LOGGING

The *Data Logging* section is subdivided into smaller sections.

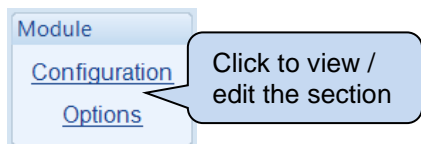

The module can record up to twenty parameters and is saved as a *Data Log File* to the module's internal memory or an external USB storage device. If 20 parameters were configured to be logged, each with a *Log Interval* of 1 second, the length of each *Data Log File* would be 6 hours and 21 minutes. This time is extendable as the length of each *Data Log File* varies upon the number of selected parameters and their configured *Log Interval*.

The module can store only one *Data Log File* to its internal memory. The number of *Data Log Files* increases when an external USB storage device is connected to the module's USB Host port. The increased number of *Data Log Files* is dependent upon the size of the USB storage device connected. When using the maximum size USB storage device of 16 GB, the number of *Data Log Files* is increased to 8200. This results in a total *Data Log* length of 46 weeks, 2 days, 6 hours, and 24 minutes (assuming 20 parameters were configured to be logged, each with a *Log Interval* of 1 second).

The *Data Logging* is viewed using the *Data Log Viewer* application, which is accessed from the DSE Configuration Suite PC Software under the *Tools* menu.

3.3.4.1 CONFIGURATION

Data Logging

	Logged data	Log Interval
1	DC Power On	1 minute
2	Left Bus Volts L-N Average	1 second
3	Right Bus Volts L-N Average	1 second
4	Bus Closed Auxiliary	1 second
5	<Not Used>	1 second
6	Left Bus Sets on Load	1 minute
7	Right Bus Sets on Load	1 minute
8	<Not Used>	1 second
9	<Not Used>	1 second
10	<Not Used>	1 second
11	<Not Used>	1 second
12	<Not Used>	1 second
13	<Not Used>	1 second
14	<Not Used>	1 second
15	<Not Used>	1 second
16	<Not Used>	1 second
17	<Not Used>	1 second
18	<Not Used>	1 second
19	<Not Used>	1 second
20	<Not Used>	1 second

Parameter	Description
Logged Data	Select the item required to be logged. Data is logged from a Specific Register, Alarms, Control, Instrumentation, or a Status item.
Log Interval	Select the logging interval of the data: 1 second to 24 hrs

3.3.4.2 OPTIONS

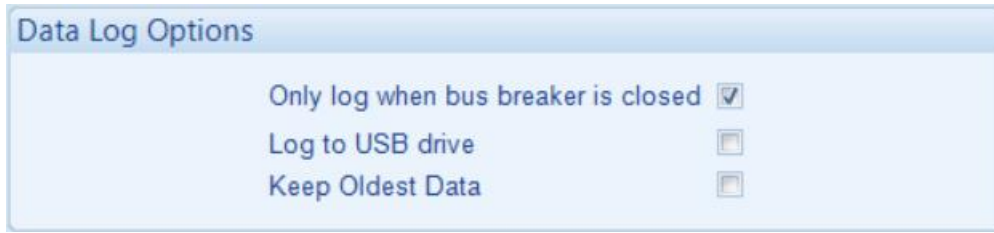

Parameter	Description
Only Log When bus breaker is closed	<input type="checkbox"/> = The module logs data regardless of breaker state. <input checked="" type="checkbox"/> = The module only logs data when the breaker is closed.
Log to USB Drive	<input type="checkbox"/> = The module logs data to the module's internal memory. <input checked="" type="checkbox"/> = The module logs data to an external USB memory device connect to the USB host socket on the module.
Keep Oldest Data	<input type="checkbox"/> = When the logging memory is full, the module overwrites the oldest data first with the new data. <input checked="" type="checkbox"/> = When the logging memory is full, the module stops recording new data.

3.4 DIGITAL INPUTS

The *digital inputs* page is subdivided into smaller sections. Select the required section with the mouse.

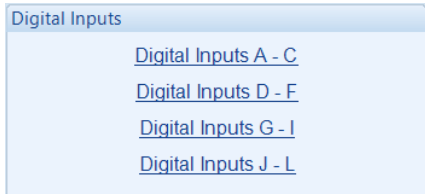

Digital Inputs A - C

Digital Input A

Function: Bus Closed Auxiliary
Polarity: Close to Activate
Action: [Greyed out]
Arming: [Greyed out]
LCD Display: Digital Input A
Activation Delay: 0s

Digital Input B

Function: User Configured
Polarity: Close to Activate
Action: Electrical Trip
Arming: Always
LCD Display: Digital Input B
Activation Delay: [Slider]

As this example shows a *predefined* function, these parameters are *greyed out* as they are not applicable.

Example of a user configured input



Close or Open to Activate

Select the type of alarm required. For details of these, see the section 5 entitled *Alarm Types*.

Configures when the input is active: Never, Always,

This is the text that will be displayed on the module screen when the alarm is triggered.



Click and drag to change the setting. This is used to give a delay on acceptance of the input. Useful for liquid level switches or to mask short term operations of the external switch device.

Parameter	Description
Function	Select the input function to activate when the relevant terminal is energised. See section entitled <i>Input Functions</i> for details of all available functions
Polarity	Select the digital input polarity: Close to Activate: the input function is activated when the relevant terminal is connected. Open to Activate: the input function is activated when the relevant terminal is disconnected.
Action	<div style="border: 1px solid black; padding: 5px;"> <p> NOTE: For details of these, see section Error! Reference source not found. entitled <i>Alarm Types</i> in this document.</p> </div> <p>Select the type of alarm required from the list: Electrical Trip Indication Warning</p>
Arming	<div style="border: 1px solid black; padding: 5px;"> <p> NOTE: For details of these, see the section 6 entitled <i>Alarm Arming</i> in this document.</p> </div> <p>Select when the alarm generated by the input becomes active: Always Never</p>
LCD Display	The text that is displayed on the module's LCD when the input activates and generates an alarm.
Activation Delay	This is used to give a delay on acceptance of the input. Useful for masking short term operations of an external switch device.

3.4.1 DIGITAL INPUT FUNCTIONS

Where a digital input is NOT configured as “user configured,” a selection is made from a list of predefined functions. The selections are as follows:

Under the scope of IEEE 37.2, function numbers can also be used to represent functions in microprocessor devices and software programs. Where the DSE input functions are represented by IEEE 37.2, the function number is listed below.

Function	Description
User Configured	This input is used to generate a custom alarm using the configured <i>Action</i> , <i>Arming</i> and <i>LCD Display</i> items.
Alarm Mute	This input is used to silence the audible alarm from an external source, such as a remote mute switch.
Alarm Reset	This input is used to reset any latched alarms from a remote location. It is also used to clear any latched warnings which may have occurred (if configured) without having to stop the generator.
Alt Config 1-5	These inputs are used to instruct the module to follow the relevant <i>alternative</i> configuration settings instead of the <i>main</i> configuration settings.
AMSC Alarms Inhibit	 NOTE: The AMSC Old Version alarm is not inhibited when this input is active.
	If this input is active, all AMSC failure related alarms are inhibited from activating even if the fault is active.
Bus Closed Auxiliary IEEE C37.2 - 3 Checking or interlocking relay	This input is used to provide feedback to allow the DSEG8680 to give true indication of the contactor or circuit breaker switching status. It should be connected to the bus tie switching device auxiliary contact.
Bus Load Inhibit IEEE 37.2 - 52 AC Circuit Breaker	This input prevents the bus tie from closing the breaker, or if the breaker is closed, causes the tie to immediately open the breaker to prevent a Bus Tie closing two buses.
Close Bus Tie	This input is used to control the closure of the bus-tie switching device.
Control Right Bus of Tie	This input allows the Bus Tie to control the RHS bus other than the default LHS bus.
External Panel Lock	This input is used to provide security to the installation. If the External Panel lock input is active, the module will not respond to operation of the control push buttons. This allows the module to be placed into a specific mode (such as Auto) and then secured. The operation of the module is not affected, and the operator will still be able to view the various instrumentation pages etc. (<i>Front panel configuration access is not possible while the system lock is active</i>).
	 NOTE: - External control sources are not affected by the external panel lock input and will continue to operate normally.
Force High Master Priority	This input forces the tie to be the highest priority when negotiating for the master arbitration token, which allows it to win control of the sets on the bus from other masters, if they are allowed to relinquish it.
Force Low Master Priority	This input forces the tie to be the lowest priority when negotiating for the master arbitration token, which forces it to hand over control of the sets on the bus to another master, if the other requires it.

Function	Description
Lamp Test	This input is used to provide a test facility for the front panel indicators fitted to the DSEG8680 module. When the input is activated, all LEDs should illuminate.
Leave AMSC Link	Causes the module to disconnect from the AMSC link without triggering alarms in other modules.
Main Config Select	This input is used to select the <i>Main</i> configuration when <i>Alternative Configurations</i> are enabled.
Simulate Auto Button	This input mimics the operation of the 'Auto' button and is used to provide a remotely located Auto mode push button.
Simulate Lamp Test \ Alarm Mute Button	This input is used to provide a test facility for the front panel indicators fitted to the module. When the input is activated, all LEDs should illuminate. The input also serves a second function, in that it also provides a mute signal to silence the audible alarm. The input is recognised by the module as though it was the Push button on the module itself being operated.
Simulate Left Switchgear Button	This input mimics the operation of the <i>Left Switchgear</i> button and is used to control bus tie breaker operations.
Simulate Manual Button	This input mimics the operation of the 'Manual' button and is used to provide a remotely located Manual mode push button.
Simulate Right Switchgear Button	This input mimics the operation of the <i>Right Switchgear</i> button and is used to control bus tie breaker operations.
Telemetry Panel Lock	Once the input is active, the module does not respond to mode changes or breaker control by telemetry. The operator is still able to control and view the various instrumentation pages through the front panel buttons.



NOTE: The master priority determines which device will obtain the master token to allow for control of generation in the current bus segment. Normally this is determined by a pre-set priority or, in the case of equal priorities, by the AMSC ID.

3.5 OUTPUTS

3.5.1 DIGITAL OUTPUTS

The screenshot shows a configuration window with two main sections: "Relay Outputs (Volts Free)" and "Digital Outputs (DC Supply Out)".

Relay Outputs (Volts Free)

	Source	Polarity
Output C (N/C)	Close Bus Output Pulse	De-Energise
Output D	Open Bus Output Pulse	Energise

Digital Outputs (DC Supply Out)

	Source	Polarity
Output E	Not Used	Energise
Output F	Not Used	Energise
Output G	Not Used	Energise
Output H	Not Used	Energise
Output I	Not Used	Energise
Output J	Not Used	Energise
Output K	Not Used	Energise
Output L	Not Used	Energise

Callout 1: "Select what the output is to be used to control" (points to the Source dropdowns in the Relay Outputs section).

Callout 2: "These labels match the typical wiring diagram" (points to the output labels E through L).

Callout 3: "Select if the relay is to energise or de-energise upon activation of the source" (points to the Polarity dropdowns in the Digital Outputs section).

The list of output sources available for configuration of the module outputs is listed in the section entitled *Output Sources*.

3.5.2 VIRTUAL LEDES

The virtual LEDs provide a configuration of 'status' items. These items are available for viewing in the SCADA section of the PC software, or read by third party systems (i.e., BMS or PLCs) using the Modbus protocol.

Virtual LEDs

LED Configuration

	Source	Polarity
LED 1	Not Used ▾	Lit ▾
LED 2	Not Used ▾	Lit ▾
LED 3	Not Used ▾	Lit ▾
LED 4	Not Used ▾	Lit ▾
LED 5	Not Used ▾	Lit ▾
LED 6	Not Used ▾	Lit ▾
LED 7	Not Used ▾	Lit ▾
LED 8	Not Used ▾	Lit ▾
LED 9	Not Used ▾	Lit ▾
LED 10	Not Used ▾	Lit ▾
LED 11	Not Used ▾	Lit ▾
LED 12	Not Used ▾	Lit ▾
LED 13	Not Used ▾	Lit ▾
LED 14	Not Used ▾	Lit ▾
LED 15	Not Used ▾	Lit ▾
LED 16	Not Used ▾	Lit ▾
LED 17	Not Used ▾	Lit ▾
LED 18	Not Used ▾	Lit ▾
LED 19	Not Used ▾	Lit ▾
LED 20	Not Used ▾	Lit ▾

Parameter	Description
Source	Select the output source to control the state of the output See section Error! Reference source not found. entitled <i>Output Sources</i> for details of all available functions
Polarity	Select the digital input polarity: Lit: When the output source is true, the virtual LED activates Unlit: When the output source is true, the virtual LED deactivates.

3.5.3 OUTPUT SOURCES

The list of output sources available for configuration of the module relay outputs also applies to the LED configuration and expansion relay outputs.

Under the scope of IEEE 37.2, function numbers can also be used to represent functions in microprocessor devices and software programs. Where the DSE output functions are represented by IEEE 37.2, the function number is listed below

Output Source	Activates...	Is Not Active....
Not Used	The output does not change state (Unused).	

3.5.3.1 ALARMS

Alarms	Output source	Activates...	Is not active....
	Display Heater Fitted and ON	Active when the display heater is on	
Alarms AMSC	AMSC Alarms Inhibited	Active when the <i>AMSC Alarms Inhibit</i> digital input function is active.	
	AMSC Data Error Port 1	Indicates bad data transfer on Port 1 of the MultiSet Comms (AMSC) Link.	
	AMSC Data Error Port 2	Indicates bad data transfer on Port 2 of the MultiSet Comms (AMSC) Link.	
	AMSC Failure	Indicates when the <i>AMSC Failure</i> alarm is active on both MultiSet Comms (AMSC) Links.	
	Invalid modules on AMSC (Mains Parallel)	Indicates that unrecognised modules have been detected on the bus.	
Alarms Bus	Left Bus Phase Rotation & Right Bus Phase Rotation Alarm	This output indicates that the module has detected a phase sequence error on the Left or Right bus.	
Alarms Common	Common Electrical Trip <i>IEEE C37.2 – 74 alarm relay</i>	Active when one or more Electrical trip alarms are active	The output is inactive when no electrical alarms are present
	Common Warning <i>IEEE C37.2 – 74 alarm relay</i>	Active when one or more Warning alarms are active	The output is inactive when no warning alarms are present
	Common Alarm <i>IEEE C37.2 – 74 alarm relay</i>	Active when one or more alarms (of any type) are active	The output is inactive when no alarms are present
Alarms Current & Power	Earth Fault Trip Alarm	Active when the Earth Fault Protection Alarm is active.	
	Negative Phase Sequence Alarm	Active when the Negative Phase Sequence Alarm is active.	
	Over Current IDMT Alarm	Active when the Over Current IDMT alarm is active.	
	Over Current Immediate Warning	Active when the Over Current Immediate Warning alarm is active.	
	Short Circuit Alarm	Active when the Short Circuit Alarm is active.	
	Unbalanced Current	Active when the Unbalanced Current Alarm is active.	
Alarms Load Switching	Bus Failed to Open <i>IEEE C37.2 - 48 Incomplete Sequence Relay</i>	This output source is intended to be used to indicate a failure of the Bus contactor or breaker..	
	Bus Failed to Close <i>IEEE C37.2 - 48 Incomplete Sequence Relay</i>	This output source is intended to be used to indicate a failure of the Bus contactor or breaker.	

Editing the Configuration

Alarms	Output source	Activates...	Is not active....
Alarms Synchronising	Out of Sync	Indicates that the Out of Sync alarm has been triggered when the supply breaker was closed.	
	Fail to Synchronise IEEE C37.2 - 48 Incomplete Sequence Relay	Becomes active if the module fails to synchronise after the fail to sync timer.	
Alarms System	Battery Low Voltage IEEE C37.2 – 27DC under voltage relay	This output indicates that a Battery Under Voltage alarm has occurred.	Inactive when battery voltage is not Low
	Battery High Voltage IEEE C37.2 – 59DC over voltage relay	This output indicates that a Battery Over voltage alarm has occurred.	Inactive when battery voltage is not High

3.5.3.2 CONTROL

Control	Output source	Activates...	Is not active....
Misc.	Lamp Test	This output indicates that the module is performing a lamp test. Once the lamp test is completed, the output will become inactive again. The output is used to feed a lamp test on external modules or panel lamps.	
	Audible Alarm IEEE C37.2 – 74 alarm relay	This output indicates that the internal sounder is operating to allow it to feed an external sounder. Operation of the Mute pushbutton will reset this output once activated.	Inactive if the internal sounder is not operating.
Load Switching	Close Bus Output IEEE 37.2 – 52 ac circuit breaker	Used to control the load switching device. Whenever the 8680 module selects the bus to be on load this control source will be active.	Inactive whenever the bus is not required to be on load
	Close Bus Output Pulse IEEE 37.2 – 52 ac circuit breaker	Used to control the load switching device. Whenever the DSE8680 module selects the bus to be on load this control source will be active for the duration of the Breaker Close Pulse timer, after which it will become inactive again.	
	Open Bus Output IEEE 37.2 – 52 AC Circuit Breaker	Used to control the load switching device. Whenever the DSE8680 module selects the bus to be off load this control source will be active.	Inactive whenever the bus is required to be on load.
	Open Bus Output Pulse IEEE 37.2 – 52 AC Circuit Breaker	Used to control the load switching device. Whenever the G8680 module selects the bus to be off load this control source will be active for the duration of the Breaker Open Pulse timer, after which it will become inactive again.	
Synchronising	Check Sync IEEE 37.2 – 25 Synchronising or Synchronising Check Relay	Indicates that the internal check synchroscope has determined that the supplies are in sync.	

3.5.3.3 STATUS

Status	Output source	Activates...	Is not active...
AMSC	Holding Token	Indicates that the module is holding the token.	
	AMSC Link Disabled	Indicates that the module has left the AMSC link.	
	AMSC No Module Holding Token	Indicates that no module is holding the token.	
	AMSC Unable To Release Token	Indicates that the module would have released the master token, but the 'Keep Holding Master Token' IP is preventing it.	
Bus	Controlling Left Bus	The module has obtained the left bus master token and is controlling the sets for synchronising/ramping.	
	Controlling Right Bus	The module has obtained the left bus master token and is controlling the sets for synchronising/ramping.	
	Left Bus Live	This output indicates that a voltage has been detected on the Left Bus. Once the voltage on the Left Bus is detected above the "Dead bus relay setting," it will no longer be considered a 'dead-bus,' and the module will need to synchronise before closing the bus if both buses are live.	
	Right Bus Live	This output indicates that a voltage has been detected on the <i>Right Bus</i> . Once the voltage on the bus is detected above the "Dead bus relay setting," it is no longer considered a 'dead-bus' and the module will need to synchronise before closing the bus if both buses are live.	
Load Switching	Bus Closed Auxiliary	Active when the Bus closed auxiliary input is active	
Language	Alternative Language Selected	This output indicates that an alternative Language has been selected.	
Module	Panel Locked	This output indicates that the module ' <i>Panel Lock</i> ' is active. If the Panel lock input is active, the module will not respond to operation of the Mode select or start buttons. This allows the module to be placed into a specific mode (such as Auto) and then secured. The operation of the module is not affected, and the operator will still be able to view the various instrumentation pages etc. (<i>Front panel configuration access is barred while system lock is active</i>).	
Inputs (Module)	Alarm Mute	Indicates that an alarm mute operation is in progress by digital input	
	Alarm Reset	Indicates that an alarm reset operation is in progress by digital input	
	DC Power On	Active when DC power is supplied to the module	
	Digital Input A - L	Active when the digital input is active	Inactive when: If the input is not active If the input is active but conditioned by activation delay, safety timer or Arming requirements.
	Left Bus Available	Active when the left bus frequency and voltage are within limits to allow synchronisation.	
	Left Bus Available Frequency	Active when the left bus frequency is within limits to allow synchronisation.	

Editing the Configuration

Status	Output source	Activates...	Is not active...
Inputs (Module)	Left Bus Available Voltage	Active when the left bus voltage is within limits to allow synchronisation.	
	Left Bus Dead	This output indicates that no voltage has been detected on the <i>Left Bus</i> and it is considered dead.	
	Left To Right Power Alarm	Activated with the alarm, the power flow from the left to right bus exceeds threshold	
	Left to Right Power Warning Alarm	Activated with the warning alarm, the power flow from the left to right bus exceeds threshold	
	Mute / Lamp Test Button Pressed	This output indicates that the alarm mute / Lamp test pushbutton is being operated. Once the button is released, the output will become inactive.	
	Panel Locked by Digital Input	This output indicates that a digital input that has been configured as 'Panel Lock' is active. If the Panel lock input is active, the module will not respond to operation of the Mode select or start buttons. This allows the module to be placed into a specific mode (such as Auto) and then secured. The operation of the module is not affected, and the operator will still be able to view the various instrumentation pages etc. (Front panel configuration access is barred while system lock is active). Refer to the 'Edit Inputs' section of this manual for details.	
	Reset Button Pressed	This output indicates that the <i>Reset Button</i> has been pressed.	
	Right Bus Available	Active when the right bus frequency and voltage are within limits to allow synchronisation.	
	Right Bus Available Frequency	Active when the right bus frequency is within limits to allow synchronisation.	
	Right Bus Available Voltage	Active when the right bus voltage is within limits to allow synchronisation.	
	Right Bus Dead	This output indicates that no voltage has been detected on the <i>Right Bus</i> and it is considered dead.	
	Right To Left Power Alarm	Activated with the alarm, the power flow from the right to left bus exceeds threshold	
	Right To Left Power Warning Alarm	Activated with the warning alarm, the power flow from the right to left bus exceeds threshold	
	Simulate Breaker Left Button	Active when the Simulate Breaker Left Button digital input is active	
	Simulate Breaker Right Button	Active when the Simulate Breaker Right Button digital input is active	
	Telemetry Panel Lock	Active when the Telemetry Panel Lock digital input is active	
Operation	Alternative Config 1-5 Selected	These inputs are used to instruct the module to follow the relevant alternative configuration settings instead of the main configuration settings.	
	Data Logging Active	Active when data is being logged	Inactive when: Data logging is disabled The engine is at rest and the option Only Log When Engine Is Running is enabled

Editing the Configuration

Status	Output source	Activates...	Is not active...
			The internal memory of the module becomes full, and the option Keep Oldest Data is enabled
	Main Config Selected	Active when the main configuration is active	
	Synching Enabled	This output indicates that the synchronisation feature has been enabled.	
	System Healthy	This output indicates that the module is in Auto mode and there are no alarms present.	
	System In Auto Mode	Active when Auto mode is selected	
	System In Manual Mode	Active when Manual mode is selected	
Remote Control	Remote Control 1-10	This output indicates that any of the module outputs, expansion outputs, LED indicators, or remote Annunciator LEDs have been configured as a Remote-Control source.	
Telemetry	Panel Locked By Telemetry	This output indicates that remote 'Panel Lock' via telemetry is active. If the Panel lock is active, the module will not respond to operation of the Mode select or start buttons. This allows the module to be controller remotely without local interference. The operation of the module is not affected, and the local operator will still be able to view the various instrumentation pages etc. (Front panel configuration access is barred while system lock is active).	
	Telemetry Active	Active when the communication port is live and for a brief time after transmission stops. This is used as a relay or LED source.	
Telemetry	Telemetry Data Active	Active when data is being transmitted. This output will change continuously state (flash) upon data transfer. Normally used as an LED source rather than a relay source as this source will flash repeatedly. For a similar source more suited to drive a relay, see Telemetry Active.	

3.6 TIMERS

Many timers are associated with alarms. Where this occurs, the timer for the alarm is located on the same page as the alarm setting. Timers not associated with an alarm are located on the *Timers* page.

The *Timer's* page is subdivided into smaller sections. Select the required section with the mouse.



3.6.1 LOAD TIMERS

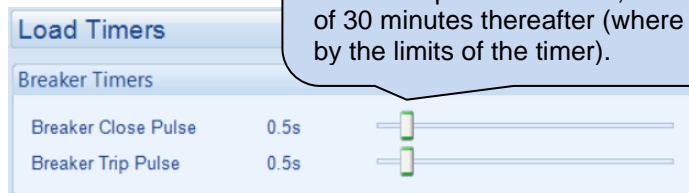

Click and drag to change the setting. Timers increment in steps of 1 second up to one minute, then in steps of 30 seconds up to 30 minutes, then in steps of 30 minutes thereafter (where allowed by the limits of the timer).

Timer	Description
Breaker close pulse	The amount of time that <i>Breaker Close Pulse</i> signals will be present when the request to close a breaker is given.
Breaker Trip pulse	The amount of time that <i>Breaker Open Pulse</i> signals will be present when the request to open a breaker is given.

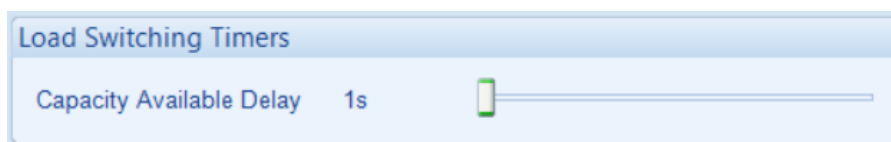

Timer	Description
Capacity Available Delay	The maximum time the bus tie requests additional capacity before giving up, when operating as a load switch.

3.6.2 MODULE TIMERS

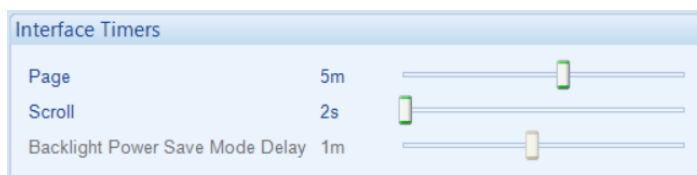

Timer	Description
LCD Page Timer	If the module is left unattended for the duration of the <i>LCD Page Timer</i> it will revert to show the <i>Status</i> page.
LCD Scroll Timer	The scroll time between parameters on a selected page
Backlight Power Save Mode Delay	The amount of Delay required before the Backlight Power Save Mode is activated.

3.7 BUS

The *bus* page is subdivided into smaller sections. Select the required section with the mouse.

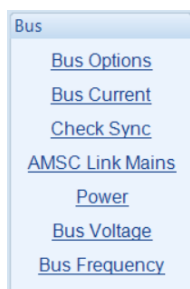

3.7.1 BUS OPTIONS

Bus Settings

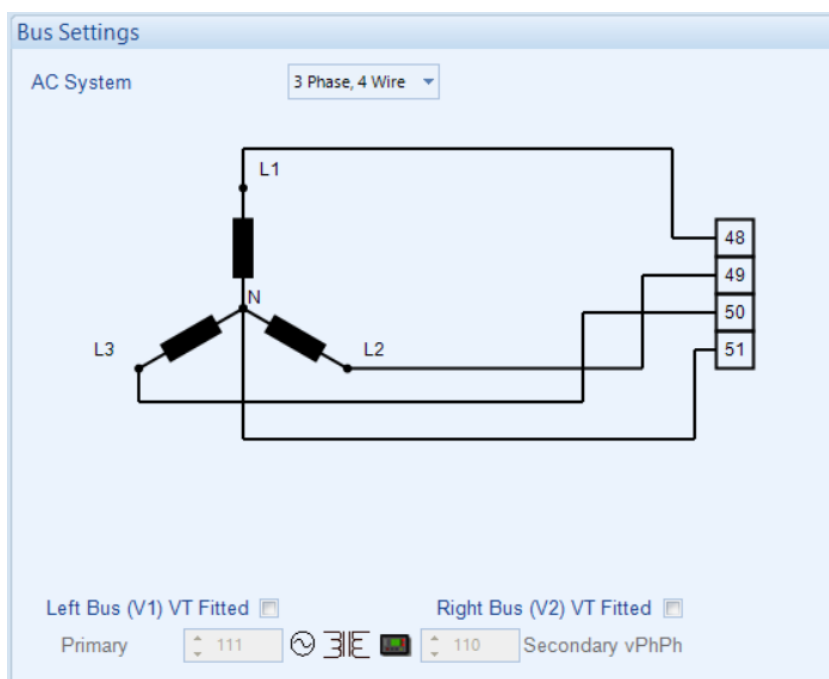

Parameter	Description
AC System	Select the AC topology of the generator from the following list: 2 Phase, 3 Wire L1 - L2 2 Phase, 3 Wire L1 - L3 3 Phase, 3 Wire 3 Phase, 3 Wire NVD 3 Phase, 4 Wire 3 Phase, 4 Wire Delta L1 - N - L2 3 Phase, 4 Wire Delta L1 - N - L3 3 Phase, 4 Wire Delta L2 - N - L3 Single Phase, 2 Wire Single Phase, 3 Wire L1 - L2 Single Phase, 3 Wire L1 - L3

Parameter descriptions are continued overleaf

Parameter	Description
Left Bus (V1) VT Fitted	<p><input type="checkbox"/> = The voltage sensing to the controller is direct from the bus. <input checked="" type="checkbox"/> = The voltage sensing to the controller is via Voltage Transformers (VTs or PTs)</p> <p>This is used to step down the Bus voltage to be within the controller voltage specifications. By entering the <i>Primary</i> and <i>Secondary</i> voltages of the transformer, the controller displays the <i>Primary</i> voltage rather than the actual measured voltage.</p> <p>This is typically used to interface the DSE module to high voltage systems (i.e., 11kV)</p>
Right Bus (V2) VT Fitted	<p><input type="checkbox"/> = The voltage sensing to the controller is direct from the bus. <input checked="" type="checkbox"/> = The voltage sensing to the controller is via Voltage Transformers (VTs or PTs)</p> <p>This is used to step down the Bus voltage to be within the controller voltage specifications. By entering the <i>Primary</i> and <i>Secondary</i> voltages of the transformer, the controller displays the <i>Primary</i> voltage rather than the actual measured voltage.</p> <p>This is typically used to interface the DSE module to high voltage systems (i.e., 11kV)</p>

Breaker Control

The screenshot shows a configuration window titled "Breaker Control". It contains the following settings:

- Enable Breaker Alarms:
- Fail to Close Delay: 1.0s (with a slider control)
- Fail to Open Delay: 1.0s (with a slider control)
- Immediate Breaker Dropout:
- Dead Bus Closing Allowed: Disabled (with a dropdown menu)

Parameter	Description
Enable Breaker Alarms	<p><input type="checkbox"/> = Alarm is disabled</p> <p><input checked="" type="checkbox"/> = The <i>Bus Failed To Close Alarm</i> and the <i>Bus Failed To Open Alarm</i> are enabled.</p> <p>During the bus closure process, when the <i>Close Bus</i> output is activated, if the configured <i>Bus Closed Auxiliary</i> digital input does not become active within the <i>Bus Fail To Close Delay</i> timer, the <i>Bus Fail to Close</i> alarm is activated.</p> <p>Or, during the bus opening process, when the <i>Close Bus</i> output is deactivated, if the configured <i>Bus Closed Auxiliary</i> digital input does not become inactive within the <i>Bus Fail To Open Delay</i> timer, the <i>Bus Fail To Open</i> alarm is activated.</p>
Fail To Open Delay	When the <i>Open Bus</i> output is activated, if the configured <i>Bus Closed Auxiliary</i> digital input does not become inactive within the <i>Bus Fail To Open Delay</i> timer, the alarm is activated
Fail To Close Delay	When the <i>Close Bus</i> output is activated, if the configured <i>Bus Closed Auxiliary</i> digital input does not become active within the <i>Bus Fail To Close Delay</i> timer, the alarm is activated
Immediate Breaker Dropout	<p><input type="checkbox"/> = Immediate Breaker Dropout is disabled</p> <p><input checked="" type="checkbox"/> = Immediate Breaker Dropout is enabled. The breaker will be opened whenever the bus is determined to be dead.</p>
Dead Bus Closing Allowed	<p>The settings available will depend on other settings selected (e.g., if Load Switching is selected in the Application setting then only Always and Right are available).</p> <p>Always: Dead bus closing is always allowed if one or both sides of the tie are dead. It's not available if "Immediate Breaker Dropout" is enabled.</p> <p>Disabled: Dead Bus closing is not allowed. Both sides of the tie bus be live for the breaker to be closed.</p> <p>Either: One side of the bus tie must be dead for the breaker to be closed; both sides may not be live and both sides may not be dead.</p> <p>Left: The left side of the tie must be dead and the right side live for the breaker to be closed.</p> <p>Right: The right side of the tie must be dead and the left side live for the breaker to be closed.</p>

 **NOTE: Available Drop-down options will depend on other options that are selected throughout the software.**

Bus Phase Rotation

Bus Phase Rotation

Phase Rotation L1-L2-L3 ▼

Parameter	Description
Bus Phase Rotation <i>IEEE 37.2 – 47 Phase Sequence Relay</i>	The <i>Bus Phase Rotation</i> setting is either clockwise (L1,L2,L3) or counter clockwise (L3,L2,L1). All the Bus Phase Rotation settings are locked to the same configuration as the Generator Phase Rotation settings.

Phase Offset

Phase Offset

Allow Editing

Phase Offset 0

Parameter	Description
Allow Editing	<input type="checkbox"/> = <i>Phase Offset</i> disabled <input checked="" type="checkbox"/> = The <i>Phase Offset</i> is enabled.
Phase Offset	Set the phase angle between the VT primary and secondary

⚠ CAUTION! Editing the phase offset is only allowed when the checkbox is ticked. This setting is only required if a phase offset is available and should not be altered otherwise. If the setting is adjusted and no phase offset is required, then crash synchronisation may occur.

3.7.2 BUS CURRENT

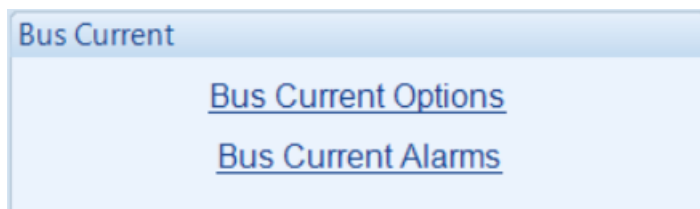

3.7.2.1 BUS CURRENT OPTIONS

Bus Current Options

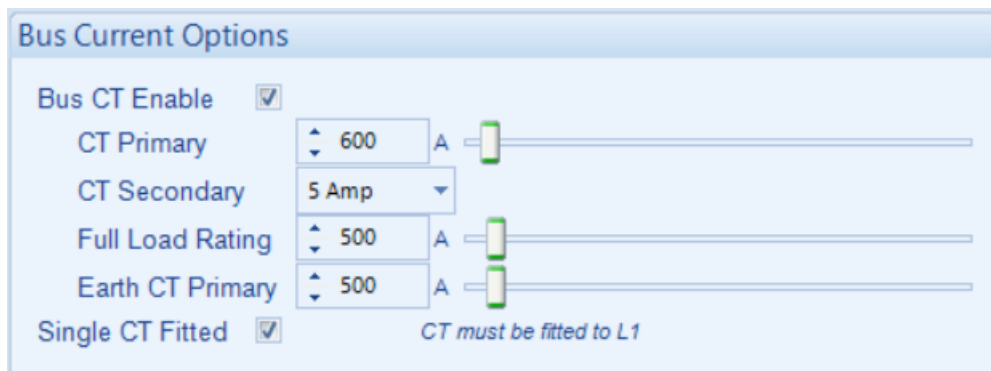

Parameter	Description
Bus CT Enable	<input type="checkbox"/> = Bus CT is disabled <input checked="" type="checkbox"/> = Bus CT is enabled
CT Primary	Primary rating of the three phase Current Transformers
CT Secondary	Secondary rating of the Current Transformers The settings are: 1 Amp: Set for 1 A CT secondary rating 5 Amp: Set for 5 A CT secondary rating
Full Load Rating	Full load rating (100% rating) of the bus supply
Earth CT Primary	Primary rating of the Current Transformer used for earth fault (optional) Where No Earth Fault CT is fitted, ensure the Earth Fault Alarm is disabled and the CT common is wired correctly.
Single CT Fitted	<input type="checkbox"/> = Single CT is disabled <input checked="" type="checkbox"/> = Single CT is enabled

3.7.2.2 BUS CURRENT ALARMS

Overcurrent Alarm

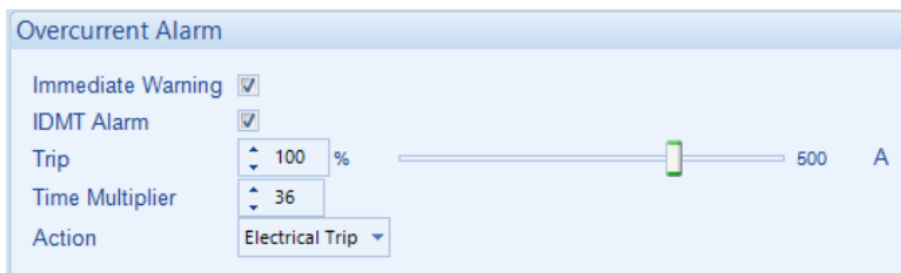

The overcurrent alarm combines a simple warning trip level combined with a fully functioning IDMT curve for thermal protection.

Parameter	Description
Immediate Warning IEEE 37.2 -50 instantaneous overcurrent relay	If the <i>Immediate Warning</i> is enabled, the controller generates a <i>warning alarm</i> as soon as the <i>Trip</i> level is reached. The alarm automatically resets once the generator loading current falls below the <i>Trip</i> level (unless <i>All Warnings are latched</i> is enabled).
IDMT Alarm IEEE 37.2 -51 AC time overcurrent relay (shutdown / electrical trip)	If the <i>Over Current IDMT Alarm</i> is enabled, the controller begins following the IDMT 'curve' when the current on any phase passes the <i>Trip</i> setting. If the <i>Trip</i> is surpassed for an excess amount of time, the <i>IDMT Alarm</i> triggers (<i>Shutdown</i> or <i>Electrical Trip</i> as selected in <i>Action</i>). The larger the over circuit fault, the faster the trip. The speed of the trip is dependent upon the fixed formula: $T = \frac{t}{\left(\frac{I_A}{I_T} - 1\right)^2}$ Where: T is the tripping time in seconds I _A is the actual measured current of the most highly loaded line (L1, L2 or L3) I _T is the delayed trip point setting in current t is the time multiplier setting and represents the tripping time in seconds at twice full load (when I _A /I _T = 2).
Trip	The percentage of full load current at which the IDMT Alarm curve starts to operate from.
Time Multiplier	The time multiplier constant throughout the IDMT curve. It also represents the tripping time in seconds at 200% full load current.
Action	Select the type of alarm required from the list: Electrical Trip Indication Warning For details of these, see the section 5 entitled <i>Alarm Types</i> .

Overcurrent Protection Explanation

The settings shown in the example below are a screen capture of the DSE factory settings, taken from the DSE Configuration Suite PC Software for a brushless alternator.

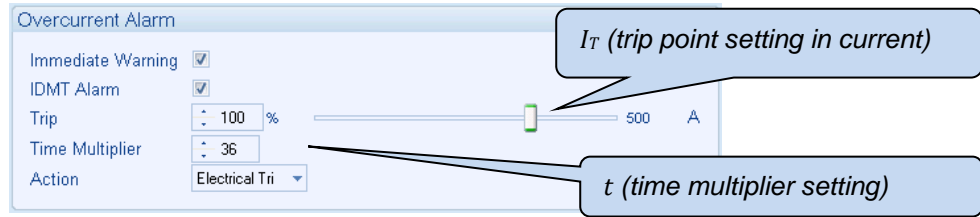

These settings provide for normal running of the generator up to 100% full load. If full load is surpassed, the *Immediate Warning* alarm is triggered, and the set continues to run.

The effect of an overload on the generator is that the alternator windings begin to overheat; the aim of the *IDMT Alarm* is to prevent the windings being overload (heated) too much. The amount of time that the alternator is safely overloaded is governed by how high the overload condition is.

The default settings as shown above allow for an overload of the alternator to the limits of the *Typical Brushless Alternator* whereby 110% overload is permitted for 1 hour or 200% overload is permitted for 36 seconds.

If the alternator load reduces, the controller then *follows* a cooling curve. This means that a second overload condition may trip soon after the first as the controller *knows* if the windings have not cooled sufficiently.

For further details on the *Thermal Damage Curve* of your alternator, refer to the alternator manufacturer and generator supplier.

Creating A Spreadsheet For the Over Current IDMT Curve

The formula used:

$$T = \frac{t}{\left(\frac{I_A}{I_T} - 1\right)^2}$$

Where:

- T is the tripping time in seconds
- I_A is the actual measured current of the most highly loaded line (L1, L2 or L3)
- I_T is the delayed trip point setting in current
- t is the time multiplier setting and represents the tripping time in seconds at twice full load (when $I_A/I_T = 2$).

The equation is simplified for addition into a spreadsheet. This is useful for 'trying out' different values of t (*time multiplier setting*) and viewing the results, without testing this on the generator.

	A	B	C	D	E	F
1		1.01	1.02	1.03	1.05	1.06
2	36	360000	90000	40000	14400	10000

t (*time multiplier setting*)

T (*tripping time in seconds*)

I_A/I_T (*multiple of the Trip setting from 1.01 to 3.0 in steps of 0.1*)

The formula for the *Tripping Time* cells is:

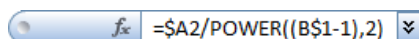

Over Current Alarm IDMT Curves

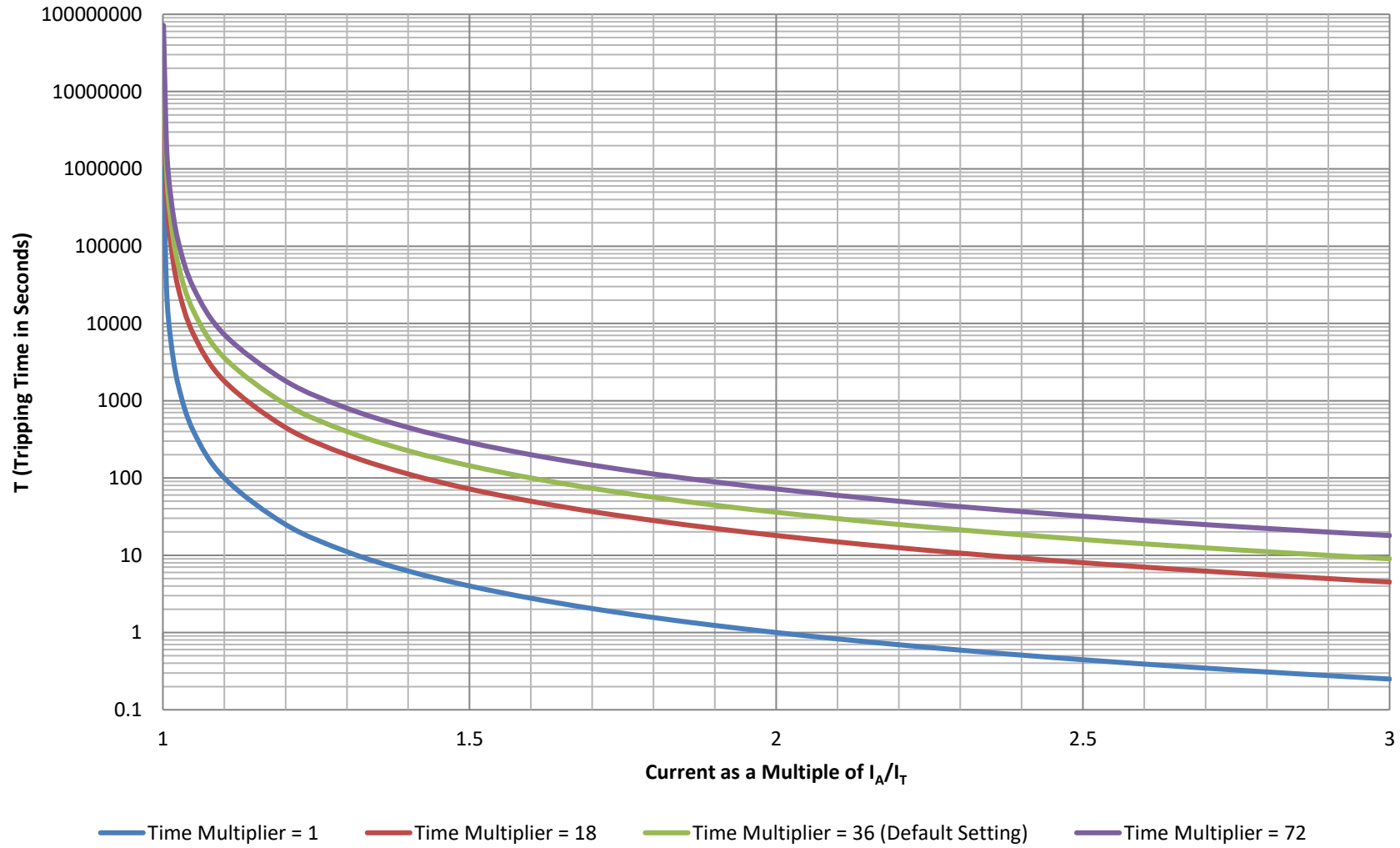

Unbalanced Current Alarm

The unbalanced current alarm is triggered by a current imbalance between the power phases. If this current exceeds the value specified (given as a percentage of the rated current) then the alarm is triggered.

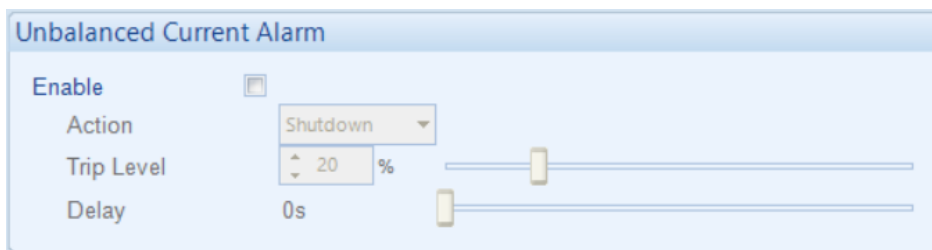

Parameter	Description
Enable	<input type="checkbox"/> = Unbalanced Current Alarm is disabled <input checked="" type="checkbox"/> = Unbalanced Current Alarm is enabled
Action	<input type="checkbox"/> = Alarm is disabled <input checked="" type="checkbox"/> = Alarm is enabled Select the type of alarm required from the list: Electrical Trip Warning
Trip Level	The trip as a percentage of full load current.
Delay	Set the amount of time before the Unbalanced Current Alarm activates.

Short Circuit

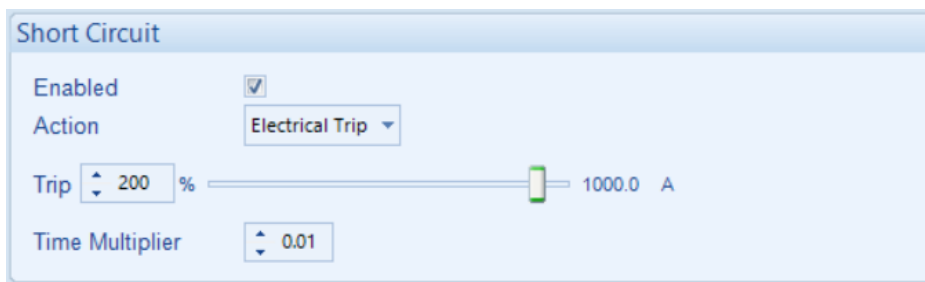

Parameter	Description
Short Circuit IDMT Enable IEEE C37.2 – 51 IDMT Short Circuit Relay	<p>If the <i>Short Circuit Alarm</i> is enabled, the controller begins following the IDMT 'curve' when the current on any phase passes the <i>Trip</i> setting.</p> <p>If the <i>Trip</i> is surpassed for an excess amount of time, the <i>IDMT Alarm</i> triggers (<i>Shutdown</i> or <i>Electrical trip</i> as selected in <i>Action</i>).</p> <p>The larger the short circuit fault, the faster the trip. The speed of the trip is dependent upon the fixed formula:</p> $T = \frac{t \times 0.14}{\left(\left(\frac{I_A}{I_T}\right)^{0.02} - 1\right)}$ <p>Where:</p> <ul style="list-style-type: none"> <i>T</i> is the tripping time in seconds (accurate to +/- 5% or +/- 50 ms (whichever is the greater)) <i>I_A</i> is the actual measured current <i>I_T</i> is the trip point setting in current <i>t</i> is the time multiplier setting
Action	<p>Select the type of alarm required from the list:</p> <p>Electrical Trip Indication Warning</p> <p>For details of these, see the section 5 entitled <i>Alarm Types</i>.</p>
Trip	The percentage of full load current at which the IDMT Alarm curve starts to operate from.
Time Multiplier	The time multiplier constant throughout the IDMT curve.

Short Circuit Protection Explanation

The settings shown in the example below are a screen capture of the DSE factory settings, taken from the DSE Configuration Suite software.

NOTE: Due to large inrush currents from certain loads, such as motors or transformers, the default settings for the Short Circuit alarm may need adjusting to compensate.

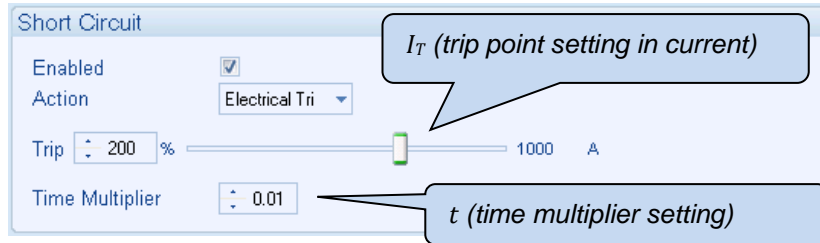

The effect of a short circuit on the generator is that the alternator stator and rotor begin to overheat; the aim of the *IDMT alarm* is to prevent the stator and rotor being overload (heated) too much. The amount of time that the alternator is safely overloaded is governed by how high the short circuit condition is.

For further details on the *Thermal & Magnetic Damage Curve* of your alternator, refer to the alternator manufacturer and generator supplier.

Creating a Spreadsheet For the Short Circuit IDMT Curve

The formula used:

$$T = \frac{t \times 0.14}{\left(\left(\frac{I_A}{I_T}\right)^{0.02} - 1\right)}$$

Where:

- T is the tripping time in seconds (accurate to +/- 5% or +/- 50 ms (whichever is the greater))
- I_A is the actual measured current
- I_T is the trip point setting in current
- t is the time multiplier setting

The equation is simplified for addition into a spreadsheet. This is useful for 'trying out' different values of t (*time multiplier setting*) and viewing the results, without testing this on the generator.

	A	B	C	D	E	F
1		1.01	1.02	1.03	1.05	1.06
2	0.01	7.034242	25	11.11111	4	2.777778

t (*time multiplier setting*)

T (*tripping time in seconds*)

I_A/I_T (*multiple of the Trip setting from 1.01 to 3.0 in steps of 0.1*)

The formula for the *Tripping Time* cells is:

$f_x = =(\$A2*0.14)/(POWER((B\$1),0.02)-1)$

Short Circuit Alarm IDMT Curves

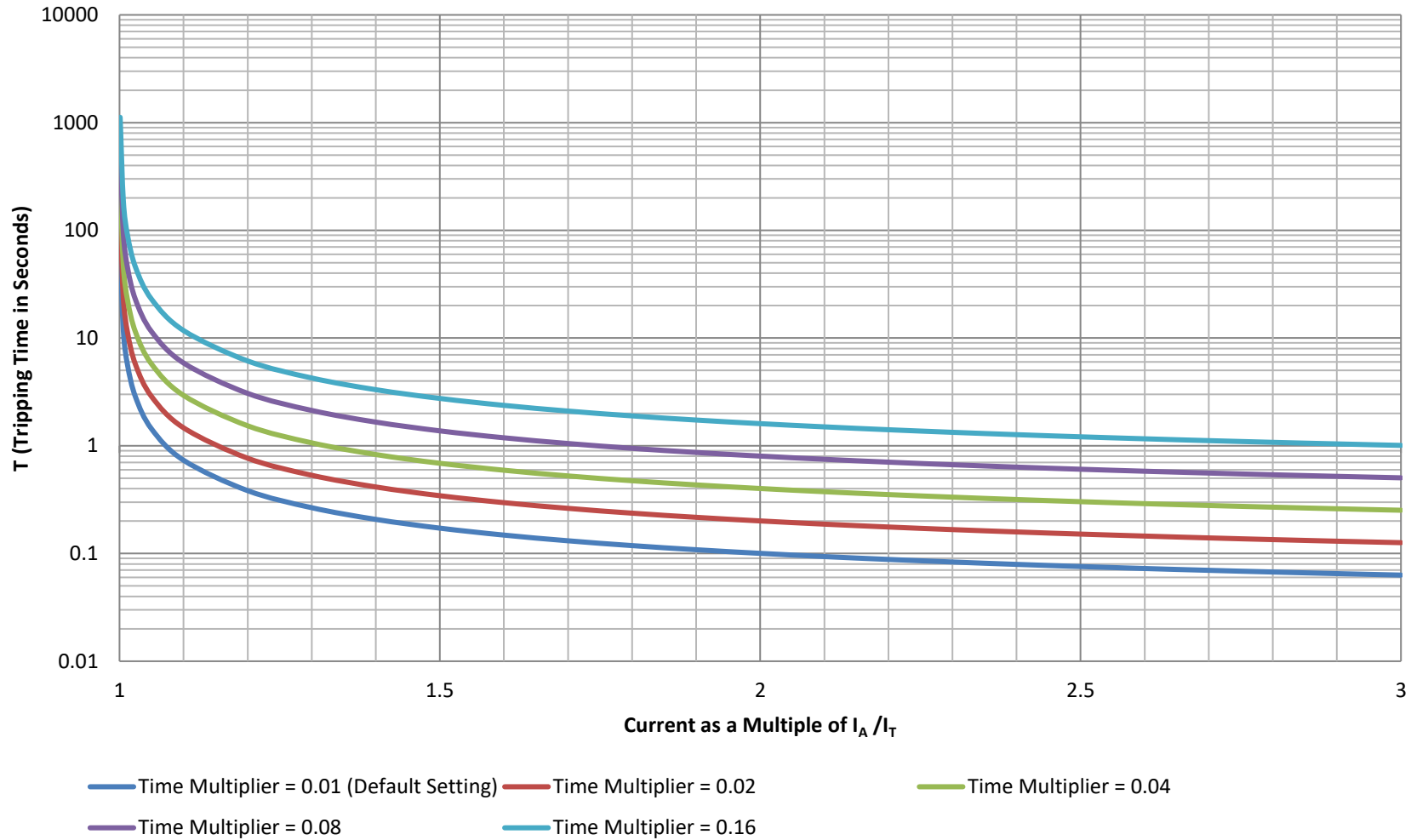

Earth Fault

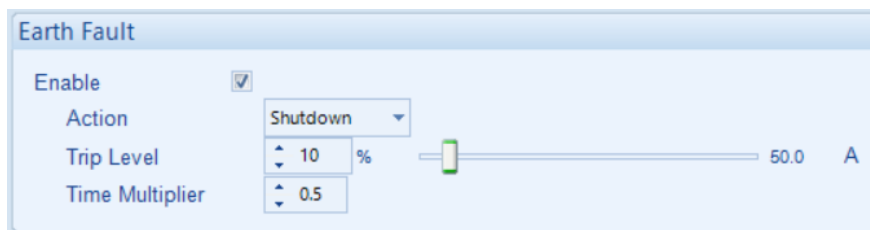

Parameter	Description
Earth Fault Enabled	<p>When the module is suitably connected using the 'Earth Fault CT.' The module measures Earth Fault and optionally configured to generate an alarm condition (shutdown or electrical trip) when a specified level is surpassed.</p> <p>If the <i>Earth Fault Alarm</i> is enabled, the controller begins following the IDMT 'curve' when the earth fault current passes the <i>Trip</i> setting.</p> <p>If the <i>Trip</i> is surpassed for an excess amount of time, the <i>IDMT Alarm</i> triggers (<i>Shutdown</i> or <i>Electrical Trip</i> as selected in <i>Action</i>).</p> <p>The larger the earth fault, the faster the trip. The speed of the trip is dependent upon the fixed formula:</p> $T = \frac{t \times 0.14}{\left(\left(\frac{I_A}{I_T}\right)^{0.02} - 1\right)}$ <p>Where:</p> <p><i>T</i> is the tripping time in seconds (accurate to +/- 5% or +/- 50ms (whichever is the greater))</p> <p><i>I_A</i> is the actual measured current</p> <p><i>I_T</i> is the trip point setting in current</p> <p><i>t</i> is the time multiplier setting</p>
Action	<p>Select the type of alarm required from the list:</p> <p>Electrical Trip</p> <p>Indication</p> <p>Warning</p> <p>For details of these, see the section 5 entitled <i>Alarm Types</i>.</p>
Trip	The percentage of the earth current at which the IDMT Alarm curve starts to operate from.
Time Multiplier	The time multiplier constant throughout the IDMT curve.

Earth Fault Protection Explanation

The settings shown in the example below are a screen capture of the DSE factory settings, taken from the DSE Configuration Suite software.

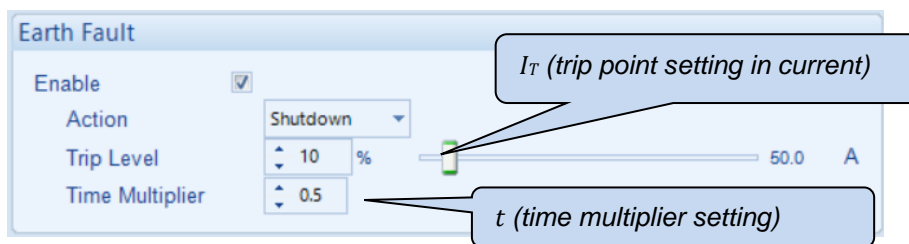

Creating A spreadsheet For the Earth Fault IDMT curve

The formula used:

$$T = \frac{t \times 0.14}{\left(\left(\frac{I_A}{I_T}\right)^{0.02} - 1\right)}$$

Where:

- T is the tripping time in seconds (accurate to +/- 5% or +/- 50 ms (whichever is the greater))
- I_A is the actual measured current
- I_T is the trip point setting in current
- t is the time multiplier setting

The equation is simplified for addition into a spreadsheet. This is useful for 'trying out' different values of t (time multiplier setting) and viewing the results, without testing this on the generator.

	A	B	C	D	E	F
1		1.01	1.02	1.03	1.05	1.06
2	0.1	70.34242	250	111.1111	40	27.77778

t (time multiplier setting)

T (tripping time in seconds)

I_A/I_T (multiple of the Trip setting from 1.01 to 3.0 in steps of 0.1)

The formula for the *Tripping Time* cells is:

```
=($A2*0.14)/(POWER((B$1),0.02)-1)
```

Earth Fault Alarm IDMT Curves

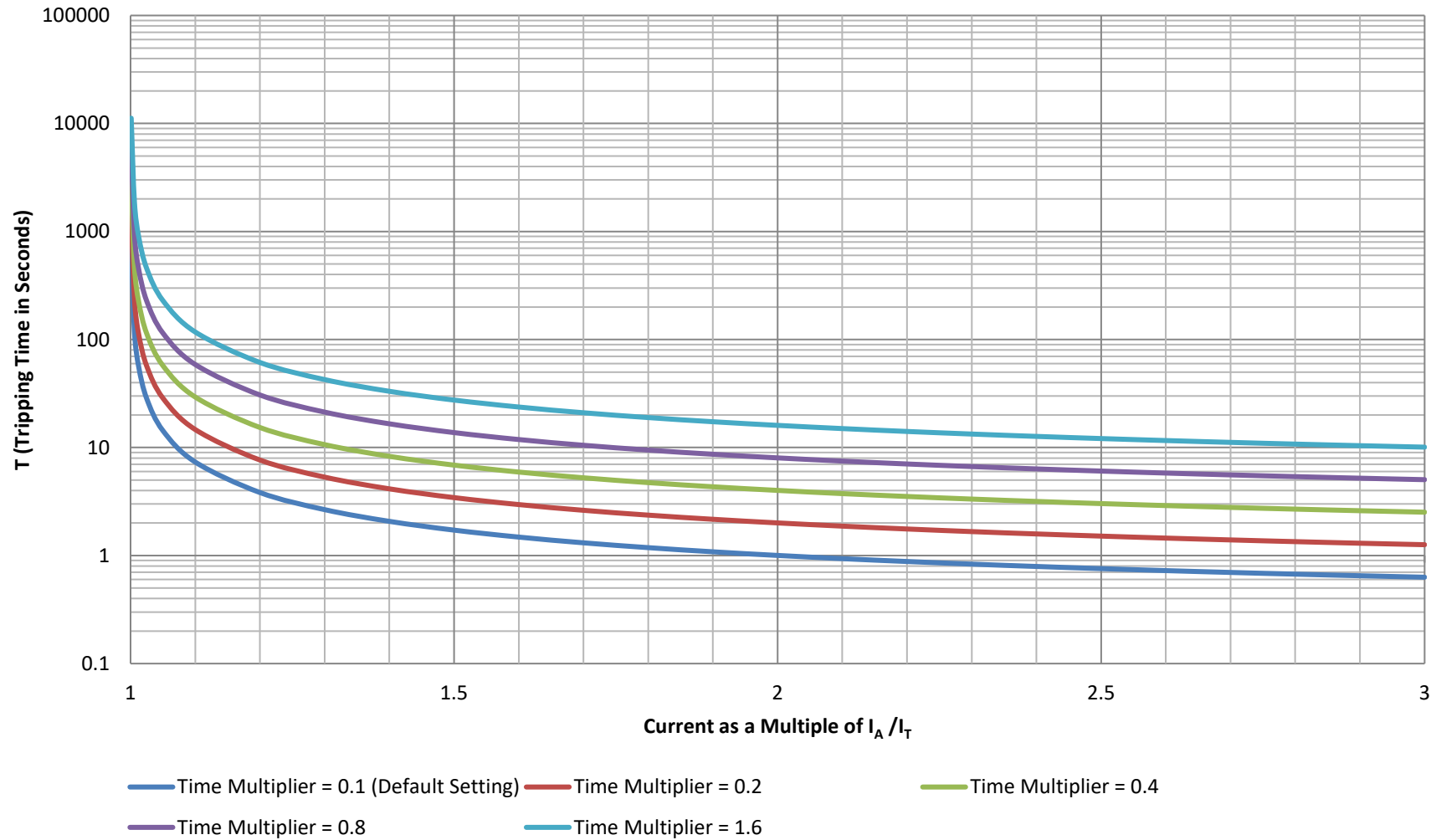

Default Current Protection IDMT Tripping Characteristics

The graph on the following page shows the default settings for the IDMT tripping curves for the *Over Current* and *Short Circuit* protections.

The default setting for the *Over Current* alarm allows for an overload of an alternator to the limits of the *Typical Brushless Alternator* whereby 110% overload is permitted for 1 hour or 200% overload is permitted for 36 seconds. In an over current situation, the alternator begins to overheat. The aim of the *Over Current IDMT Alarm* is to prevent the windings being overloaded (heated) too much. The amount of time that the alternator is safely overloaded is governed by how high the overload condition is.

The default setting for the *Short Circuit* alarm allows for an alternator to supply a high current caused by a genuine short circuit or an in-rush current of a motor/transformer. Whereby 300% overload is permitted for 0.17 seconds, or 600% overload is permitted for 0.06 seconds. In a short circuit situation, the alternator begins to overheat to the point the insulation breaks down, potentially causing a fire. The aim of the *Short Circuit IDMT Alarm* is to prevent the insulation from melting due to excessive heat. The amount of time that the alternator runs safely in a short circuit condition is governed by the alternator's construction.

The default setting for the *Earth Fault* alarm allows for an alternator to supply a fault current caused by a high impedance short to earth or motor drives. Whereby 12% fault current is permitted for 3.83 second or 20% fault current is permitted for 1 second.

DSE Default Configuration of Over Current, Short Circuit & Earth Fault IDMT Alarm Curves

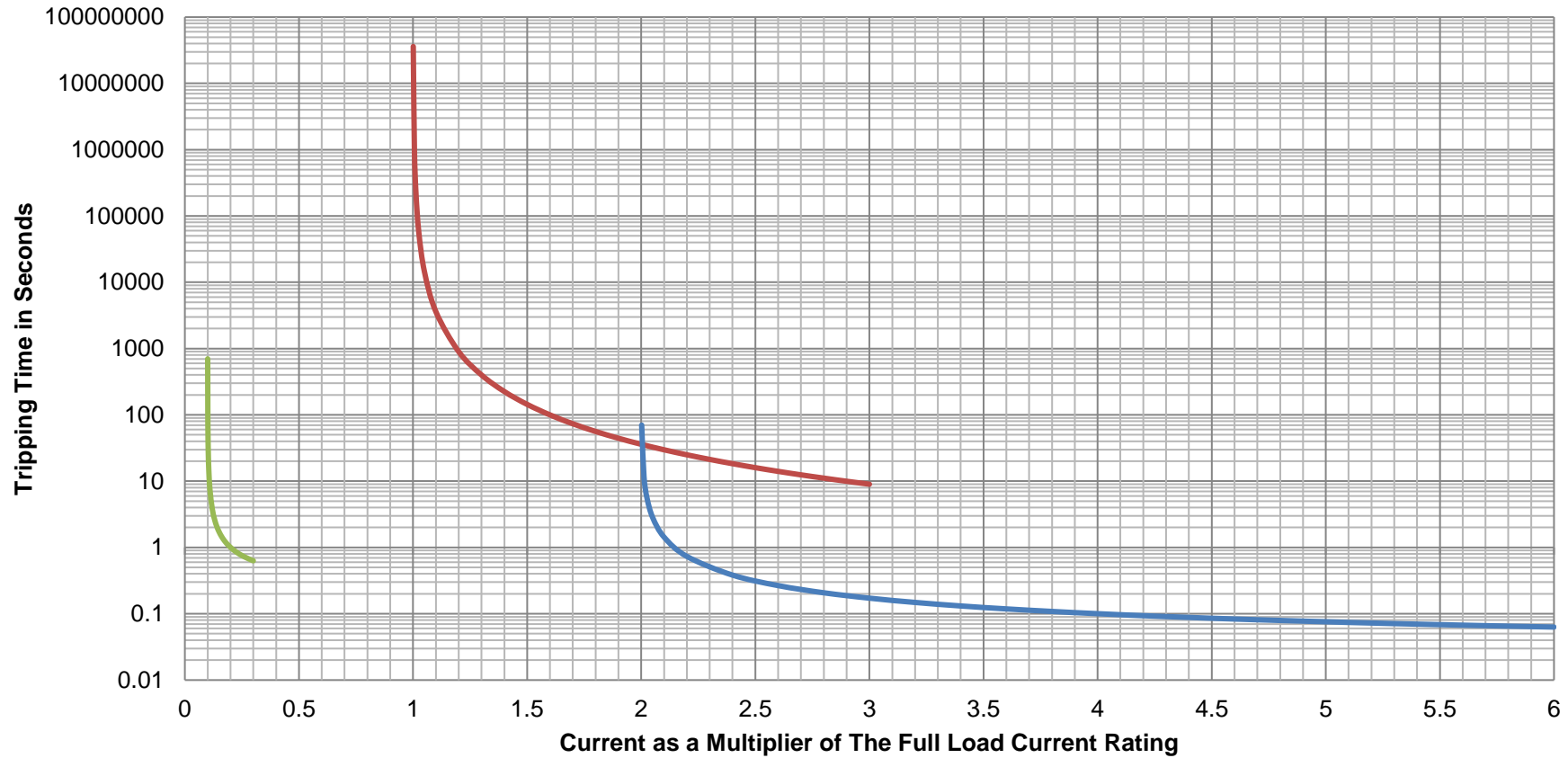

- Over Circuit IDMT Trip Curve with Time Multiplier = 36, Trip Point = 100% (Default Settings)
- Short Circuit IDMT Trip Curve with Time Multiplier = 0.01, Trip Point = 200% (Default Settings)
- Earth Fault IDMT Trip Curve with Time Multiplier = 0.1, Trip Point = 10% (Default Settings)

3.7.2.3 CHECK SYNC

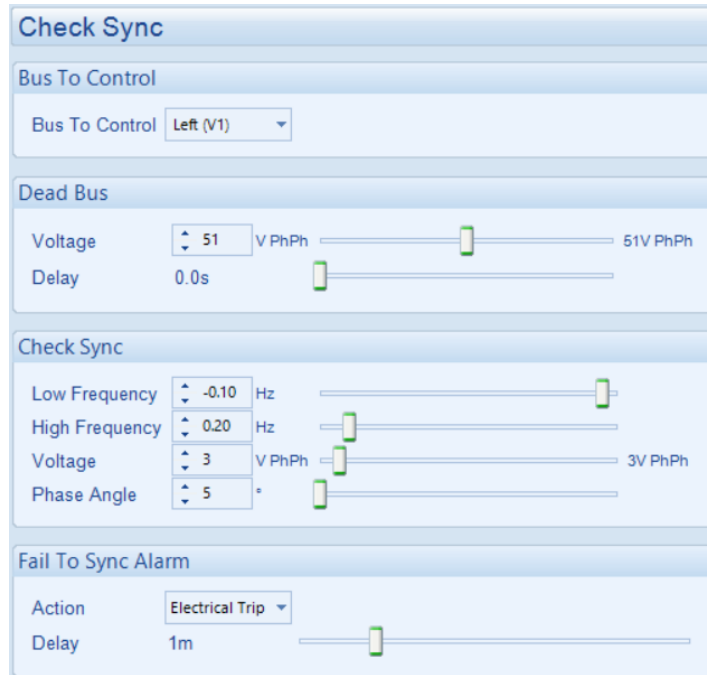

Parameter	Description
Bus to control	<p>During synchronisation when triggered by the "close bus tie" input, one bus is controlled to synchronise with the other. This setting determines which bus is controlled by the DSEG8680.</p> <p>The options are:</p> <p>Left (V1): Select for left bus V1 Right(V2): Select for right bus V2</p>
Dead Bus Voltage	<p>The bus is measured when loaded. If the bus is measured to be below the <i>Dead Bus Voltage</i>, the bus is assumed to be 'dead' and the breaker is closed immediately.</p> <p>If the bus is measured to be above the <i>Dead Bus Voltage</i>, the oncoming generator must be synchronised before the breaker is closed.</p>
Dead Bus Delay	<p>When the load switch is closed, the bus voltage is measured a short time later, determined by Delay. Should the bus voltage be below the level of the Dead Bus Voltage setting, the Bus Not Live electrical trip alarm is raised.</p>
Check Sync	<p>During the synchronising process, the DSE8680 will synchronises the two busses. Typically the oncoming set will be adjusted to be 0.1Hz faster than the existing supply.</p> <p>This causes the phase of the two supplies to change continuously.</p> <p>Before the breaker is closed, the following conditions must be met:</p> <ul style="list-style-type: none"> • The difference between the two supplies frequencies must be between the <i>Check Sync Low Frequency</i> and <i>Check Sync High Frequency</i> • The difference between the two supplies voltages must be equal to or below the <i>Check Sync Voltage</i> • The phase of the two supplies must be equal to or below the <i>Check Sync Phase Angle</i>
Fail to sync Alarm	<p>If the synchronising process continues longer that the <i>Fail to Sync Alarm Delay</i>, the alarm is triggered.</p> <p>This may occur if changes in the load are making the set control difficult due to changes in voltage and frequency.</p> <p>Select the type of alarm required from the list:</p> <p>Electrical Trip: Latched Indication: Warning Always Latched:</p>

3.7.2.4 AMSC LINK

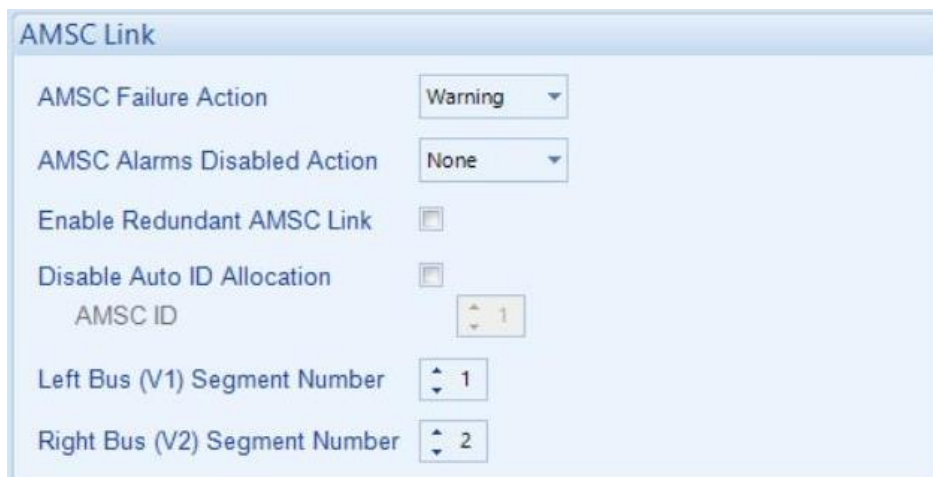

Parameter	Description
AMSC Failure Action	Action upon AMSC Link Failure: Electrical Trip: The breaker is opened immediately. Indication: No alarm is raised. This is used for internal use, such as in the PLC Logic or Virtual LEDs. Warning: A warning alarm is activated.
AMSC Alarms Disabled Action	Action to take when the AMSC alarm is disabled by a digital input: Indication: No alarm is raised. This is used for internal use, such as in the PLC Logic or Virtual LEDs. None: Alarm is disabled. Warning: A warning alarm is activated.
Enable Redundant AMSC Link	<input type="checkbox"/> = Only one Multi-Set Comms (AMSC) Link is active. <input checked="" type="checkbox"/> = This activates the second (redundant) Multi-Set Comms (AMSC) Link, allowing for communications redundancy between the controllers.
Disable Auto ID Allocation	<input type="checkbox"/> = The AMSC system assigns the AMSC ID automatically when the DSE module is powered up. <input checked="" type="checkbox"/> = The AMSC system does not assign the AMSC ID automatically when the DSE module is powered up, instead the DSE module uses the AMSC ID number configured in this section up to a maximum of 64.
Left Bus (V1) Segment Number	An unique identifier number corresponding to all modules on the Left Bus (V1) section up to a maximum of 64.
Right Bus (V2) Segment Number	An unique identifier number corresponding to all modules on the Right Bus (V2) section up to a maximum of 64.

3.7.3 POWER

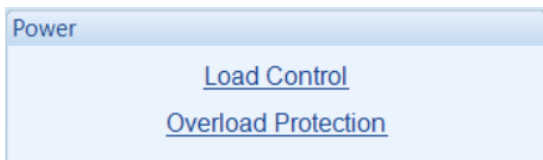

3.7.3.1 LOAD CONTROL

Load Share Ramp

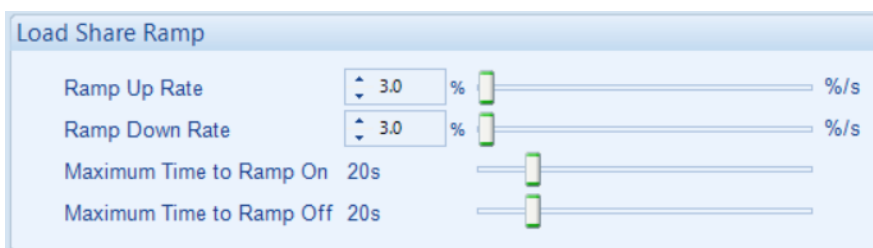

Parameter	Description
Ramp Up Rate	The rate at which the bus tie raises the power levels when ramping on or off.
Ramp Down Rate	The rate at which the bus tie lowers the power levels when ramping on or off.
Maximum Time to Ramp On	This is to set a time limit to the ramp on process, and it is useful when the generators responses are slow or are not capable to ramp on the load. The Ramp On Load timer starts when the tie begins to ramp on. When this timer is expired the ramping ends regardless of the actual power.
Maximum Time to Ramp OFF	This is to set a time limit to the ramp off process, and it is useful when the engine responses are slow or are not capable to ramp off the load. The Ramp Off Load timer is the maximum time allowed for the ramp off process. The actual time allowed is proportional to the magnitude of the power level that is to be ramped off prior to the breaker opening. For smaller power levels the time is reduced proportionally The timer starts when the tie begins to ramp off. When this timer is expired the breaker opens regardless of the actual power. It is possible to set the ramp rate slower than this time, so the breaker opens prior to the ramp finishing.

NOTE: Before opening the tie the generators on a specified side of the Bus Tie are ramped down until the power through it is zero, then the breaker is opened. After closing the breaker, the generators on a specified side of the Bus Tie are ramped up or down as needed until the load is the same % on both sizes. If CTs are not fitted then the ramping off goes to the target values using the AMSC power levels.

3.7.3.2 OVERLOAD PROTECTION

Left to Right Power Protection

The screenshot shows a configuration window titled "Left to Right Power Protection". It contains two main sections: "Pre-Alarm" and "Alarm".

- Pre-Alarm:**
 - Checked (checkbox).
 - Action: "Warning" (dropdown menu).
 - Trip: 310 kW (slider).
 - Return: 276 kW (slider).
 - Delay: 5s (slider).
- Alarm:**
 - Checked (checkbox).
 - Trip: 345 kW (slider).
 - Delay: 5s (slider).

Parameter	Description
Pre-Alarm	<input type="checkbox"/> = <i>Left to Right Power Protection</i> Pre-Alarm is disabled <input checked="" type="checkbox"/> = <i>Left to Right Power Protection</i> Pre- Alarm gives a warning in the event of the power rising above the configured <i>Left to Right Power Protection Pre-Alarm Trip</i> value for longer than the <i>Delay</i> . Once the power falls below the <i>Left to Right Power Protection Return</i> the alarm is reset. The <i>Left to Right Power Protection Pre-Alarm Trip</i> value is adjustable to suit user requirements.
Action	Select the type of alarm required from the list: Indication Warning For details of these, see the section Error! Reference source not found. entitled <i>Alarm Types</i> in this document.
Alarm	<input type="checkbox"/> = <i>Left to Right Power Protection</i> alarm is disabled <input checked="" type="checkbox"/> = <i>Left to Right Power Protection</i> alarm is enabled. in the event of the power rising above the configured <i>Left to Right Power Trip</i> value for longer than the <i>Delay</i> .
Trip	Set the percentage of total power at which the <i>Left To Right Power Protection Alarm</i> is activated
Delay	This is used to delay the <i>Left to Right Power Protection Alarm</i> . Useful to prevent short term peaks of power causing the generator to shut down

Right to Left Power Protection

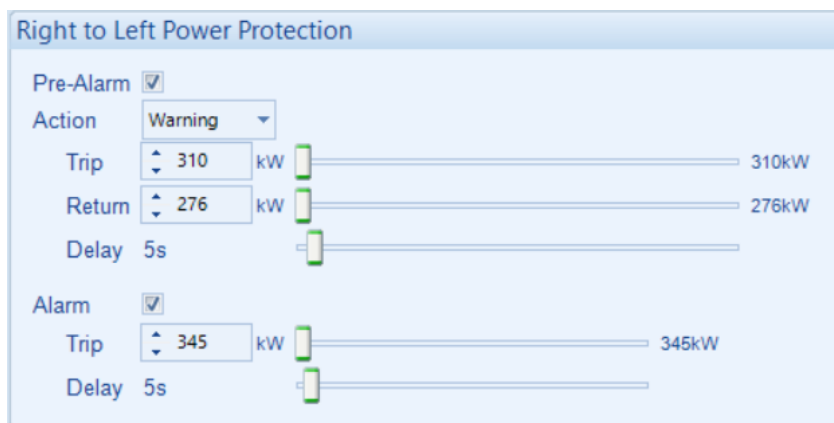

Parameter	Description
Pre-Alarm	<input type="checkbox"/> = <i>Right to Left Power Protection</i> Pre-Alarm is disabled <input checked="" type="checkbox"/> = <i>Right to Left Power Protection</i> Pre- Alarm gives a warning in the event of the power rising above the configured <i>Right to Left Power Protection Pre-Alarm Trip</i> value for longer than the <i>Delay</i> . Once the power falls below the <i>Right to Left Power Return</i> the alarm is reset. The <i>Right to Left Power Protection Pre-Alarm Trip</i> value is adjustable to suit user requirements.
Action	Select the type of alarm required from the list: Indication Warning For details of these, see the section Error! Reference source not found. entitled <i>Alarm Types</i> in this document.
Alarm	<input type="checkbox"/> = <i>Right to Left Power Protection</i> alarm is disabled <input checked="" type="checkbox"/> = <i>Right to Left Power Protection</i> alarm is enabled. in the event of the power rising above the configured <i>Right to Left Power Trip</i> value for longer than the <i>Delay</i> .
Trip	Set the percentage of total power at which the <i>Right To Left Power Protection Alarm</i> is activated
Delay	This is used to delay the <i>Right to Left Power Protection Alarm</i> . Useful to prevent short term peaks of power causing the generator to shut down

3.7.4 BUS VOLTAGE

Bus Voltage

[Left Bus Voltage Thresholds](#)

[Right Bus Voltage Thresholds](#)

3.7.4.1 LEFT BUS VOLTAGE THRESHOLDS

Nominal Voltage

Nominal Voltage V PhPh 398V PhPh

Dead Bus

Voltage V PhPh 689V PhPh

Bus Availability Voltage

Low V PhPh 398V PhPh

High V PhPh 606V PhPh

Parameter	Description
Nominal Voltage	This is used to instruct the module what voltage to adjust the Left Bus to whilst running on load. It is also used when the Left and right bus VTs have different ratios, to synchronise the voltage of both supplies.
Dead Bus Voltage	The voltage below which the bus is assumed to be 'dead.'
Bus Availability Voltage	The high and low voltage limits between which the synchroniser can operate.

3.7.4.2 RIGHT BUS VOLTAGE THRESHOLDS

The screenshot shows a configuration interface with three main sections, each with a title bar and a control area:

- Nominal Voltage:** A title bar with the text "Nominal Voltage". Below it, a control area contains a numerical input field set to "398" followed by "V PhPh" and a slider control. The slider's range is marked from "398V PhPh" on the left to "398V PhPh" on the right.
- Dead Bus:** A title bar with the text "Dead Bus". Below it, a control area contains a numerical input field set to "689" followed by "V PhPh" and a slider control. The slider's range is marked from "689V PhPh" on the left to "689V PhPh" on the right.
- Bus Availability Voltage:** A title bar with the text "Bus Availability Voltage". Below it, there are two control areas:
 - Low:** A numerical input field set to "398" followed by "V PhPh" and a slider control. The slider's range is marked from "398V PhPh" on the left to "398V PhPh" on the right.
 - High:** A numerical input field set to "606" followed by "V PhPh" and a slider control. The slider's range is marked from "606V PhPh" on the left to "606V PhPh" on the right.

Parameter	Description
Nominal Voltage	This is used to instruct the module what voltage to adjust the Left Bus to whilst running on load. It is also used when the Left and right bus VTs have different ratios, to synchronise the voltage of both supplies.
Dead Bus Voltage	The voltage below which the bus is assumed to be 'dead.'
Bus Availability Voltage	The high and low voltage limits between which the synchroniser can operate.

3.7.5 BUS FREQUENCY

Bus Frequency

- [Frequency Thresholds](#)
- [Left Bus Frequency Thresholds](#)
- [Right Bus Frequency Thresholds](#)

3.7.6 FREQUENCY THRESHOLDS

Nominal Frequency

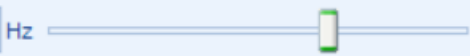
Nominal Frequency Hz  50.0 Hz

Parameter	Description
Nominal Frequency	This is used to instruct the module what frequency to adjust the buses to whilst running on load.

3.7.7 LEFT BUS FREQUENCY THRESHOLDS

Dead Bus

Frequency Hz  10.0 Hz

Bus Availability Frequency

Low Hz  45.0 Hz

High Hz  52.0 Hz

Parameter	Description
Frequency	This is used to instruct the module what frequency to adjust the Left Bus to whilst running on load. It is also used when the left and right bus VTs have different ratios, to synchronise the frequency of both supplies.
Bus Availability Frequency	The bus is available when between the high and low limits

3.7.8 RIGHT BUS FREQUENCY THRESHOLDS



Parameter	Description
Frequency	This is used to instruct the module what frequency to adjust the Left Bus to whilst running on load. It is also used when the left and right bus VTs have different ratios, to synchronise the voltage of both supplies.
Dead Bus Frequency	The frequency below which the bus is assumed to be 'dead.'
Bus Availability Frequency	The bus is available when between the high and low limits

3.8 SYSTEM

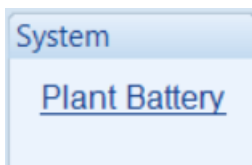

3.8.1 PLANT BATTERY

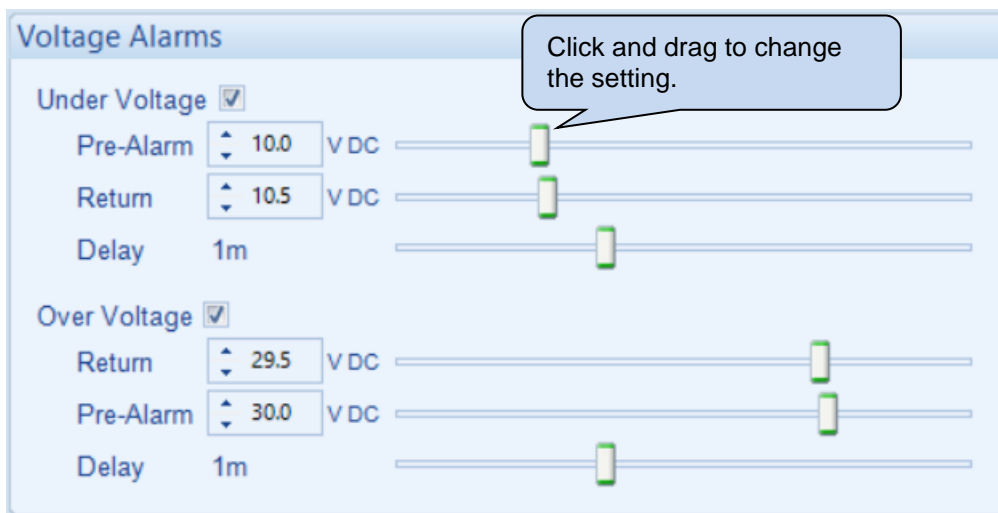

Parameter	Description
Plant Battery Under Voltage IEEE 37.2 -27 DC Undervoltage Relay	<input type="checkbox"/> = The alarm is disabled. <input checked="" type="checkbox"/> = The alarm activates when the battery voltage drops below the configured <i>Pre-Alarm</i> level for the configured <i>Delay</i> time. When the battery voltage rises above the configured <i>Return</i> level, the alarm is de-activated.
Plant Battery Over Voltage IEEE 37.2 -59 DC Overvoltage Relay	<input type="checkbox"/> = The alarm is disabled. <input checked="" type="checkbox"/> = The alarm activates when the battery voltage rises above the configured <i>Pre-Alarm</i> level for the configured <i>Delay</i> time. When the battery voltage drops below the configured <i>Return</i> level, the alarm is de-activated.

3.9 COMMUNICATIONS

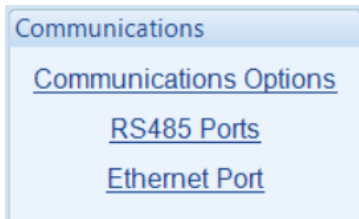

3.9.1 COMMUNICATION OPTIONS

Provides a means of giving the control an identity name. This is used in the SCADA section to allow the operator to see the site name and genset identity that is currently connected to the SCADA. As this could be a remote module connected over modem or Ethernet connection this is an extremely useful feature.

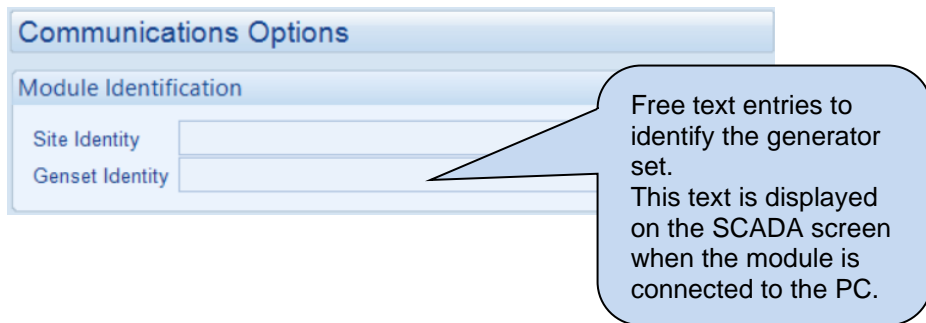

3.9.2 RS485 PORT

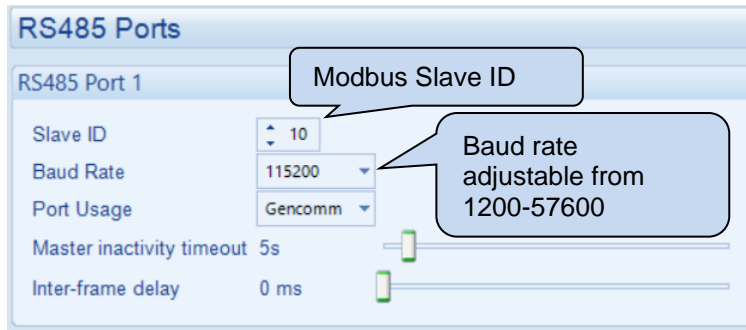

Parameter	Description
Slave ID	Select the Slave ID of the DSE module's RS485 port. Every device on the RS485 link must have an individual Slave ID.
Baud Rate	Select the Baud Rate (speed of communication) of the DSE module's RS485 port. Every device on the RS485 link must have the same Baud Rate. 1200 2400 4800 9600 14400 19200 28800 38400 57600 115200
Port Usage	<p>NOTE: In a system for a <i>PLC Comms</i> application, only one DSE module must be configured to act as the PLC master. For further details and instructions on using <i>the PLC Comms</i>, refer to DSE Publication: <i>057-314 Advanced PLC Software Manual</i> which is found on our website: www.deepseaelectronics.com</p> <p>Select the RS485 Port1 usage. Gencomm: MODBUS RTU RS485 communication PLC Comms: The RS485 Port 1 is used to read the other controllers' registers over the RS485 link which are defined in the <i>PLC Editor</i>.</p>
Master Inactivity Timeout	The module monitors by default the USB port for communications. When activity is detected on the RS485 port, the module monitors the port for further data. If no data activity is detected on the port for the duration of the <i>Master Inactivity Timer</i> , it reverts to looking at the USB port. This needs to be set longer than the time between MODBUS polls from the master.
Inter-frame Delay	Set the time delay between the DSE module receiving a MODBUS RTU request and the DSE module's response.

3.10 ETHERNET PORT

NOTE: Consult the network administrator of the host network before changing these settings. Incorrect settings cause network errors in the existing local area network. Qualified network administrators must only change these settings.

Dynamic Host Configuration Protocol

Dynamic Host Configuration Protocol

Obtain IP Address Automatically

Parameter	Description
Obtain IP Address Automatically	<p><input type="checkbox"/> = The Dynamic Host Configuration Protocol (DHCP) is disabled and the unit has a fixed IP address as configured in the <i>IP Address</i> section.</p> <p><input checked="" type="checkbox"/> = The Dynamic Host Configuration Protocol (DHCP) is enabled, and the unit automatically attains an IP address from the network it is connected to if it has DHCP enabled.</p>

Names

Names

Domain Name: DSE Module

Host Name: Company

Vendor Name: Deep Sea Electronics

Parameter	Description
Domain Name	The hostname of the device which is used for DHCP requests and acknowledgements. Consult the network IT manager for suitable naming
Host Name	Additional description string for DHCP
Vendor Name	Additional description string for DHCP

IP Address

IP Addresses

IP address	192	. 168	. 1	. 100
Subnet Mask	255	. 255	. 255	. 0
Gateway Address	0	. 0	. 0	. 0
DNS Address	0	. 0	. 0	. 0
Preferred Connection Address	0	. 0	. 0	. 0

Parameter	Description
IP Address	The static IP address of the module.
Subnet Mask	The subnet mask is to determine whether the module is on the local subnet or on a remote network.
Gateway Address	IP address of the internet router that module is connected to.
DNS Address	IP address of the Domain Name Service (DNS)
Preferred Connection Address	The module allows up to five MODBUS masters to connect to it. The <i>Preferred Connection Address</i> enables the unit to reserve one of the five connections for a specific IP address, such as for a remote display module to ensure it always connects.

MODBUS

Modbus

Modbus Port Number

Parameter	Description
MODBUS Port Number	The port number which the module serves MODBUS traffic on.

3.11 ALTERNATIVE CONFIGURATIONS

An Alternative Configurations are provided to allow the system designer to cater for different AC requirements using the same system. Typically, this feature is used by Rental Set Manufacturers where the set is capable of being operated at (for instance) 120 V 50 Hz and 240V 50 Hz using a selector switch.

The Alternative Configuration is selected using either:

- Configuration Suite Software (Selection for 'Default Configuration')
- Via external signal to the module input configured to "Alternative Configuration" select.

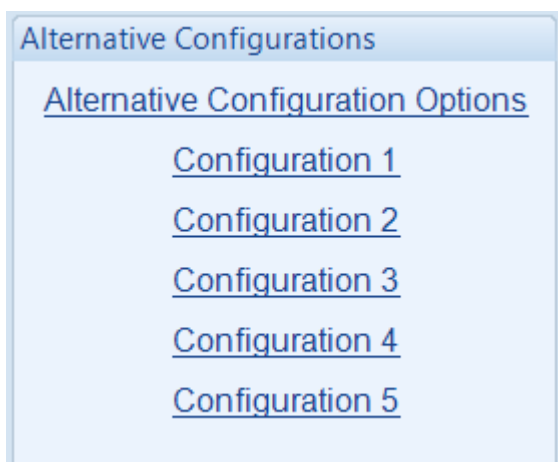

3.11.1 ALTERNATIVE CONFIGURATION OPTIONS

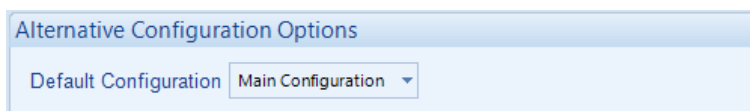

Parameter	Description
Default Configuration	Select the 'default' configuration that is used when there is no instruction to use an 'alternative configuration.'

3.11.2 ALTERNATIVE CONFIGURATION 1 TO 5

The Alternative Configurations Editor allows for editing of the parameters that are to be changed when an Alternative Configuration is selected.



Select the alternative configuration required.

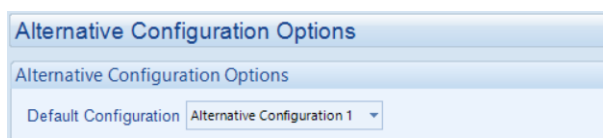

3.11.2.1 CONFIGURATION OPTIONS

Enable Alternative Configuration

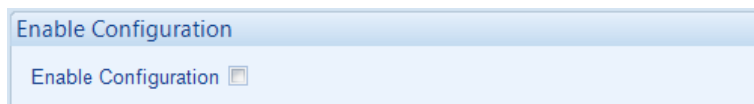
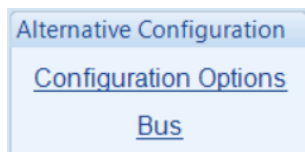

Parameter	Description
Enable Configuration	<input type="checkbox"/> = <i>Alternative Configuration</i> is disabled. <input checked="" type="checkbox"/> = <i>Alternative Configuration</i> is enabled. The configuration is enabled by changing the <i>Default Configuration</i> or activating a digital input.

3.11.2.2 BUS

Alternative configuration options contain a subset of the main configuration. The adjustable parameters are not discussed here as they are identical to the main configuration options:

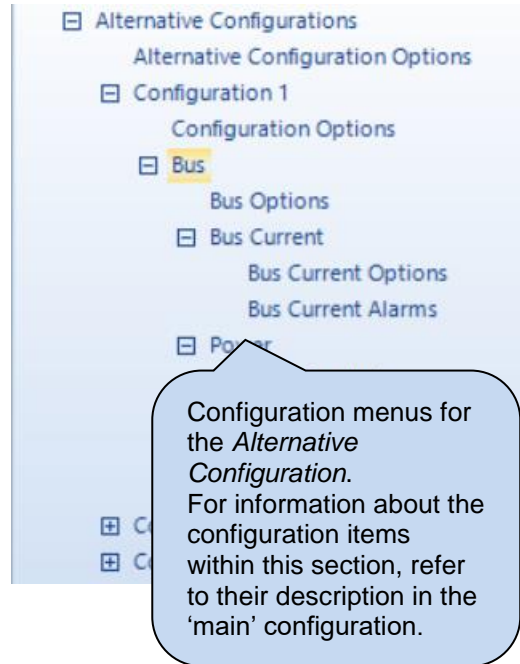
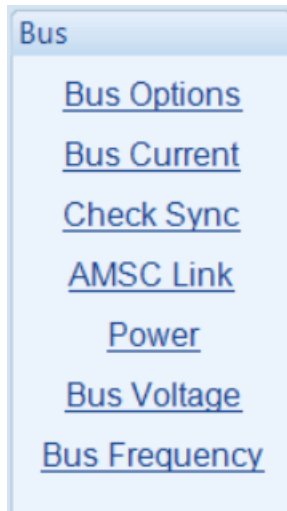

3.12 EXPANSION

▲NOTE: In the event of a comms failure to an expansion module the controller will no longer respond. If a digital input is critical then the alarm on the expansion module should be set to *Electrical Trip*. If the link is lost to an expansion unit, then it behaves as if it is powered down.

The *Expansion* page is subdivided into smaller sections.
Select the required section with the mouse.

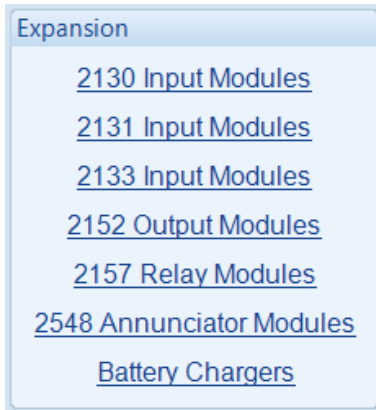

See overleaf for description of the different expansion modules.

3.12.1 DSE2130 INPUT MODULES

Select the DSENet ID of the input expansion to be configured. The ID of the expansion module is set by rotary decimal switch accessible under the removable cover of the device.

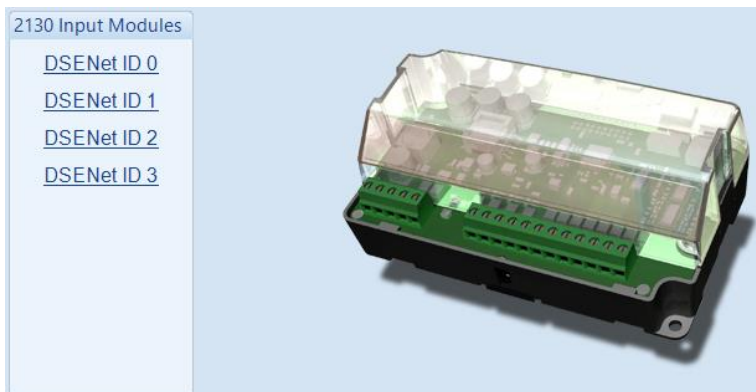

The following options are then shown:

2130 Expansion Enable

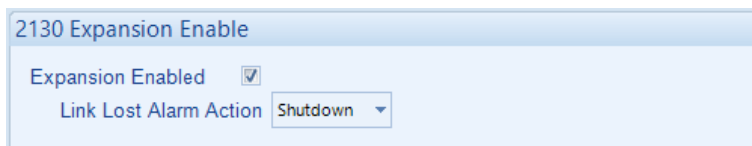

Parameter	Description
Expansion Enabled	<input type="checkbox"/> = The expansion module with the selected ID is not enabled. <input checked="" type="checkbox"/> = The expansion module with the selected ID is enabled. If the expansion module is not connected / detected by the module, the module generates an <i>Exp. Unit Failure</i> alarm with the configured <i>Link Lost Alarm Action</i> severity.

2130 Expansion Inputs

The *Expansion Unit* page is then subdivided into smaller sections. Select the required section with the mouse.

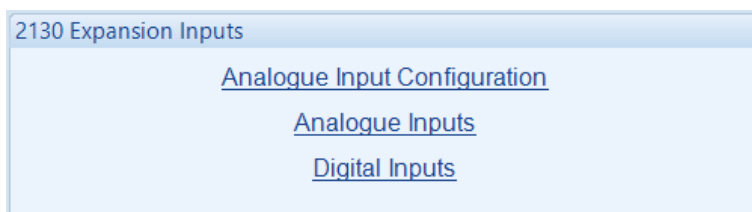

3.12.1.1 ANALOGUE INPUT CONFIGURATION

Input Configuration

Parameter	Description
Analogue Input E to H	Select what the analogue input is to be used for: Not Used: The analogue input is disabled Digital Input: Configured on the 2130/Digital Inputs pages Flexible Analogue: Configured on the 2130/Analogue Inputs pages

3.12.1.2 ANALOGUE INPUTS

NOTE: An analogue input is only configurable as a flexible sensor if it has been configured as Flexible Analogue, refer to section Error! Reference source not found. entitled **Analogue Input Configuration** in this document for further details.

Sensor Description

Parameter	Description
Sensor Name	Enter the <i>Sensor Name</i> , this text is shown on the module display when viewing the instrument.

Input Type

Parameter	Description
Input Type	Select the sensor type and curve from a pre-defined list or create a user-defined curve. Available sensor types: Resistive: for sensors with maximum range of 0 Ω to 480 Ω Available parameters to be measured: Pressure: The input is configured as a pressure sensor Percentage: The input is configured as a percentage sensor Temperature: The input is configured as a temperature sensor

Sensor Alarms

Parameter	Description
Alarm Arming	<p>NOTE: For details of these, see the section 6 entitled <i>Alarm Arming</i> in this document.</p> <p>Select when the alarm generated by the analogue input becomes active: Always From Safety On From Starting</p>
Low Alarm Enable	<p><input type="checkbox"/> = The Alarm is disabled. <input checked="" type="checkbox"/> = The <i>Low Alarm</i> activates when the measured quantity drops below the <i>Low Alarm</i> setting.</p>
Low Alarm Action	<p>NOTE: For details of these, see the section Error! Reference source not found. entitled <i>Alarm Types</i> in this document.</p> <p>Select the type of alarm required from the list: Electrical Trip</p>
Low Pre-Alarm Enable	<p><input type="checkbox"/> = The Pre-Alarm is disabled. <input checked="" type="checkbox"/> = The <i>Low Pre-Alarm</i> is active when the measured quantity drops below the <i>Low Pre-Alarm Trip</i> setting. The <i>Low Pre-Alarm</i> is automatically reset when the measured quantity rises above the configured <i>Low Pre-Alarm Return</i> level.</p>
Low Alarm String	<p>The text that is displayed on the module's LCD when the <i>Low Alarm</i> or <i>Low Pre-Alarm</i> activates.</p>
High Pre-Alarm Enable	<p><input type="checkbox"/> = The Pre-Alarm is disabled. <input checked="" type="checkbox"/> = The <i>High Pre-Alarm</i> is active when the measured quantity rises above the <i>High Pre-Alarm Trip</i> setting. The <i>High Pre-Alarm</i> is automatically reset when the measured quantity falls below the configured <i>High Pre-Alarm Return</i> level.</p>
High Alarm Enable	<p><input type="checkbox"/> = The Alarm is disabled. <input checked="" type="checkbox"/> = The <i>High Alarm</i> is active when the measured quantity rises above the <i>High Alarm</i> setting.</p>

Parameter descriptions are continued overleaf...

Parameter	Description
High Alarm Action	<div data-bbox="450 212 1374 302" style="border: 1px solid black; padding: 2px;">  NOTE: For details of these, see the section Error! Reference source not found. entitled <i>Alarm Types</i> in this document. </div> <p>Select the type of alarm required from the list: <i>Electrical Trip</i></p>
High Alarm String	The text that is displayed on the module's LCD when the <i>High Alarm</i> or <i>High Pre-Alarm</i> activates.

3.12.1.3 DIGITAL INPUTS

The *Digital Inputs* section is subdivided into smaller sections. Select the required section with the mouse.

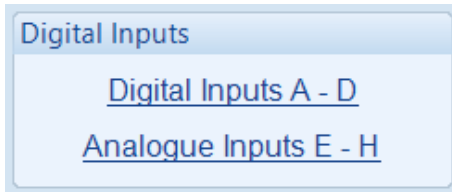

3.12.1.3.1 DIGITAL INPUTS

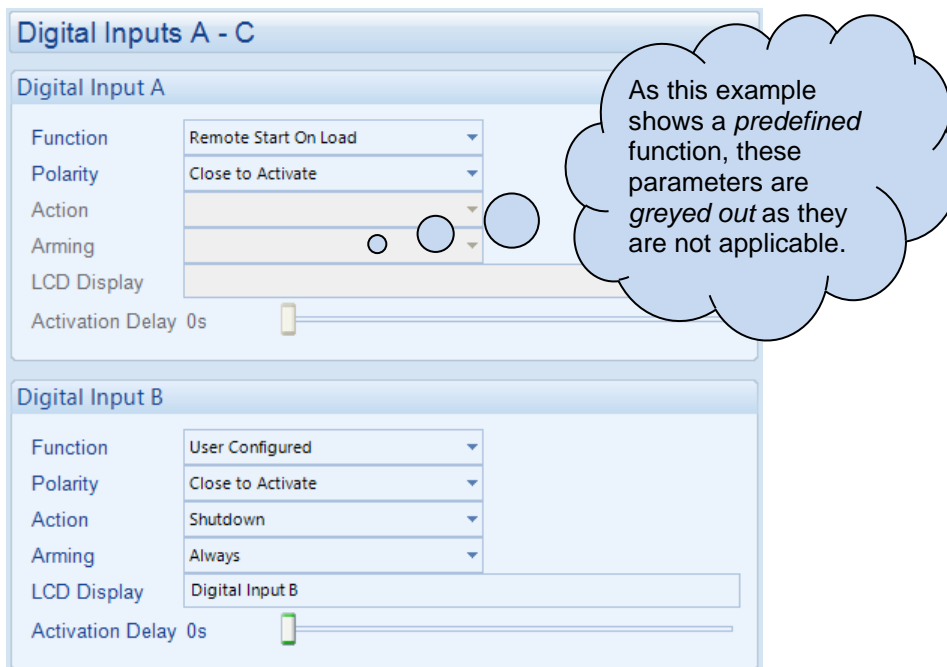

Parameter	Description
Function	Select the input function to activate when the relevant terminal is energised. See section entitled <i>Input Functions</i> for details of all available functions
Polarity	Select the digital input polarity: Close to Activate: the input function is activated when the relevant terminal is connected. Open to Activate: the input function is activated when the relevant terminal is disconnected.
Action	<div style="border: 1px solid black; padding: 5px;"> <p>⚠ NOTE: For details of these, see the section Error! Reference source not found. entitled <i>Alarm Types</i> in this document.</p> </div> <p>Select the type of alarm required from the list: Electrical Trip Indication Warning</p>
Arming	<div style="border: 1px solid black; padding: 5px;"> <p>⚠ NOTE: For details of these, see the section 6 entitled <i>Alarm Arming</i> in this document.</p> </div> <p>Select when the input becomes active: Always Never</p>
LCD Display	The text that is displayed on the module's LCD when the input activates and generates an alarm.
Activation Delay	This is used to give a delay on acceptance of the input. Useful for liquid level switches or to mask short term operations of the external switch device.

3.12.1.3.2 ANALOGUE INPUTS

NOTE: An analogue input is only configurable as a digital input if it has been configured as Digital Input, refer to section Error! Reference source not found. entitled *Analogue Input Configuration* in this document for further details.

Analogue Inputs E - H

Analogue Input E (Digital)

Function	User Configured
Polarity	Close to Activate
Action	Warning
Arming	Always
LCD Display	2130 ID0 Analogue E (Digital)
Activation Delay	0s <input type="text" value="0"/>

Analogue Input F (Digital)

The Analogue Input is not configured as a Digital Input
To reconfigure, use the 'Analogue Input Configuration' page

Parameter	Description
Function	Select the input function to activate when the relevant terminal is energised. See section entitled <i>Input Functions</i> for details of all available functions
Polarity	Select the digital input polarity: Close to Activate: the input function is activated when the relevant terminal is connected. Open to Activate: the input function is activated when the relevant terminal is disconnected.
Action	<div style="border: 1px solid black; padding: 5px; margin-bottom: 5px;"> <p>NOTE: For details of these, see the section Error! Reference source not found. entitled <i>Alarm Types</i> in this document.</p> </div> <p>Select the type of alarm required from the list: Electrical Trip Indication Warning</p>
Arming	<div style="border: 1px solid black; padding: 5px; margin-bottom: 5px;"> <p>NOTE: For details of these, see the section 6 entitled <i>Alarm Arming</i> in this document.</p> </div> <p>Select when the input becomes active: Always Never</p>
LCD Display	The text that is displayed on the module's LCD when the input activates and generates an alarm.
Activation Delay	This is used to give a delay on acceptance of the input. Useful for liquid level switches or to mask short term operations of the external switch device.

3.12.2 DSE2131 INPUT MODULES

Select the DSENet ID of the input expansion to be configured. The ID of the expansion module is set by rotary decimal switch accessible under the removable cover of the device.



The following options are then shown:

2131 Expansion Enable

2131 Expansion Enable

Expansion Enabled

Link Lost Alarm Action Shutdown

Parameter	Description
Expansion Enabled	<input type="checkbox"/> = The expansion module with the selected ID is not enabled. <input checked="" type="checkbox"/> = The expansion module with the selected ID is enabled. If the expansion module is not connected / detected by the module, the module generates an <i>Exp. Unit Failure</i> alarm with the configured <i>Link Lost Alarm Action</i> severity.
Link Lost Alarm Action	Select the type of alarm required from the list: Electrical Trip:: Warning:

2131 Expansion Inputs

The *Expansion Unit* page is then subdivided into smaller sections. Select the required section with the mouse.

2131 Expansion Inputs

[Analogue Input Configuration](#)
[Analogue Inputs](#)
[Digital Inputs](#)

3.12.2.1 ANALOGUE INPUT CONFIGURATION

Input Configuration

Analogue Input A	Flexible Analogue ▾
Analogue Input B	Flexible Analogue ▾
Analogue Input C	Not Used ▾
Analogue Input D	Flexible Analogue ▾
Analogue Input E	Digital Input ▾
Analogue Input F	Digital Input ▾
Analogue Input G	Digital Input ▾
Analogue Input H	Flexible Analogue ▾
Analogue Input I	Digital Input ▾
Analogue Input J	Not Used ▾

Input Configuration

Parameter	Description
Analogue Input A to J	Select what the analogue input is to be used for: Not Used: The analogue input is disabled Digital Input: Configured on the 2131/Digital Inputs pages Flexible Analogue: Configured on the 2131/Analogue Inputs pages

3.12.2.2 ANALOGUE INPUTS

 **NOTE:** An analogue input is only configurable as a flexible sensor if it has been configured as Flexible Analogue input.

Sensor Description

Sensor Description

Sensor Name

Parameter	Description
Sensor Name	Enter the <i>Sensor Name</i> , this text is shown on the module display when viewing the instrument.

Input Type

Input Type

VDO Ohm range (10-180)

Parameter	Description
Input Type	<p>Select the sensor type and curve from a pre-defined list or create a user-defined curve.</p> <p>Available sensor types: Current: for sensors with maximum range of 0 mA to 20 mA Resistive: for sensors with maximum range of 0 Ω to 1920 Ω Voltage: for sensors with maximum range of 0 V to 10 V</p> <p>Available parameters to be measured: Pressure: The input is configured as a pressure sensor Percentage: The input is configured as a percentage sensor Temperature: The input is configured as a temperature sensor</p>

Sensor Alarms

Parameter	Description
Alarm Arming	<p>NOTE: For details of these, see the section 6 entitled <i>Alarm Arming</i> in this document.</p> <p>Select when the alarm generated by the analogue input becomes active: Always From Safety On From Starting</p>
Low Alarm Enable	<p><input type="checkbox"/> = The Alarm is disabled. <input checked="" type="checkbox"/> = The <i>Low Alarm</i> activates when the measured quantity drops below the <i>Low Alarm</i> setting.</p>
Low Alarm Action	<p>NOTE: For details of these, see the section Error! Reference source not found. entitled <i>Alarm Types</i> in this document.</p> <p>Select the type of alarm required from the list: Electrical Trip</p>
Low Pre-Alarm Enable	<p><input type="checkbox"/> = The Pre-Alarm is disabled. <input checked="" type="checkbox"/> = The <i>Low Pre-Alarm</i> is active when the measured quantity drops below the <i>Low Pre-Alarm Trip</i> setting. The <i>Low Pre-Alarm</i> is automatically reset when the measured quantity rises above the configured <i>Low Pre-Alarm Return</i> level.</p>
Low Alarm String	<p>The text that is displayed on the module's LCD when the <i>Low Alarm</i> or <i>Low Pre-Alarm</i> activates.</p>

Parameter descriptions are continued overleaf...

Parameter	Description
High Pre-Alarm Enable	<input type="checkbox"/> = The Pre-Alarm is disabled. <input checked="" type="checkbox"/> = The <i>High Pre-Alarm</i> is active when the measured quantity rises above the <i>High Pre-Alarm Trip</i> setting. The <i>High Pre-Alarm</i> is automatically reset when the measured quantity falls below the configured <i>High Pre-Alarm Return</i> level.
High Alarm Enable	<input type="checkbox"/> = The Alarm is disabled. <input checked="" type="checkbox"/> = The <i>High Alarm</i> is active when the measured quantity rises above the <i>High Alarm</i> setting.
High Alarm Action	<div style="border: 1px solid black; padding: 5px;">  NOTE: For details of these, see the section Error! Reference source not found. entitled <i>Alarm Types</i> in this document. </div> <p>Select the type of alarm required from the list: <i>Electrical Trip</i></p>
High Alarm String	The text that is displayed on the module's LCD when the <i>High Alarm</i> or <i>High Pre-Alarm</i> activates.

3.12.2.3 DIGITAL INPUTS



NOTE: An analogue input is only configurable as a digital input if it has been configured as Digital Input.

The screenshot shows a configuration page titled "Analogue Inputs A - C". It is divided into three sections:

- Analogue Input A (Digital):** This section is for a predefined function. The "Function" dropdown is set to "Alarm Mute". The "Polarity" dropdown is set to "Close to Activate". The "Action" and "Arming" dropdowns are greyed out. The "LCD Display" field contains "2131 ID0 Flexible Sensor A". The "Activation Delay" is set to "0s".
- Analogue Input B (Digital):** This section is for a user-configured function. The "Function" dropdown is set to "User Configured". The "Polarity" dropdown is set to "Close to Activate". The "Action" dropdown is set to "Warning". The "Arming" dropdown is set to "Always". The "LCD Display" field contains "2131 ID0 Flexible Sensor B". The "Activation Delay" is set to "0s".
- Analogue Input C (Digital):** This section contains a message: "The Analogue Input is not configured as a Digital Input. To reconfigure, use the 'Analogue Input Configuration' page".

A blue callout bubble points to the greyed-out parameters in the Analogue Input A section, containing the text: "As this example shows a predefined function, these parameters are greyed out as they are not applicable."

Parameter descriptions are overleaf...

Parameter	Description
Function	Select the input function to activate when the relevant terminal is energised. See section entitled <i>Input Functions</i> for details of all available functions
Polarity	Select the digital input polarity: Close to Activate: The input function is activated when the relevant terminal is connected. Open to Activate: The input function is activated when the relevant terminal is disconnected.
Action	<div style="border: 1px solid black; padding: 5px;">  NOTE: For details of these, see the section Error! Reference source not found. entitled <i>Alarm Types</i> in this document. </div> Select the type of alarm required from the list: Electrical Trip Indication Warning
Arming	<div style="border: 1px solid black; padding: 5px;">  NOTE: For details of these, see the section 6 entitled <i>Alarm Arming</i> in this document. </div> Select when the input becomes active: Always Never
LCD Display	The text that is displayed on the module's LCD when the input activates and generates an alarm.
Activation Delay	This is used to give a delay on acceptance of the input. Useful for liquid level switches or to mask short term operations of the external switch device.

3.12.3 DSE2133 INPUT MODULES

Select the DSENet ID of the input expansion to be configured. The ID of the expansion module is set by rotary decimal switch accessible under the removable cover of the device.

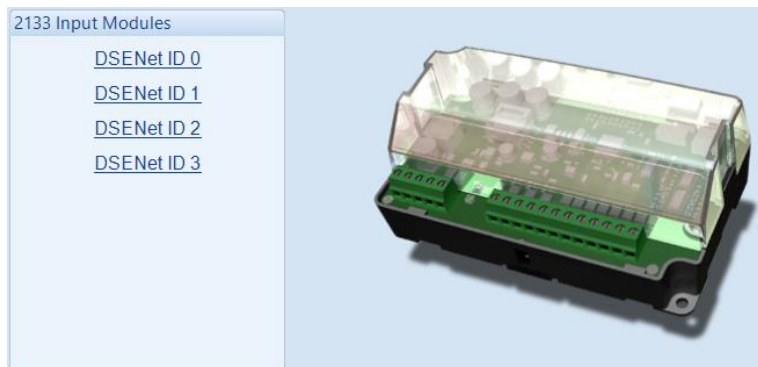

The following options are then shown:

2133 Expansion Enable

2133 Expansion Enable

Expansion Enabled

Link Lost Alarm Action Shutdown ▼

Parameter	Description
Expansion Enabled	<input type="checkbox"/> = The expansion module with the selected ID is not enabled. <input checked="" type="checkbox"/> = The expansion module with the selected ID is enabled. If the expansion module is not connected / detected by the module, the module generates an <i>Exp. Unit Failure</i> alarm with the configured <i>Link Lost Alarm Action</i> severity.
Link Lost Alarm Action	Select the type of alarm required from the list: Electrical Trip: Warning:

2133 Expansion Inputs

The *Expansion Unit* page is then subdivided into smaller sections. Select the required section with the mouse.

2133 Expansion Inputs

[Inputs A - H](#)

3.12.3.1 ANALOGUE INPUTS

NOTE: An analogue input is only configurable as a flexible sensor if it has been configured as Flexible Analogue, refer to section Error! Reference source not found. entitled *Analogue Input Configuration* in this document for further details.

Sensor Description

Sensor Description

Sensor Name

Parameter	Description
Sensor Name	Enter the <i>Sensor Name</i> , this text is shown on the module display when viewing the instrument.

Input Type

Input Type

Parameter	Description
Input Type	Select the sensor type from the pre-defined list: 2 Wire PT100 3 Wire PT100 <i>Type J (Thermocouple)</i> <i>Type K (Thermocouple)</i>

Sensor Alarms

Parameter	Description
Alarm Arming	<p> NOTE: For details of these, see the section 6 entitled <i>Alarm Arming</i> in this document.</p> <p>Select when the alarm generated by the analogue input becomes active: <i>Always</i> <i>From Safety On</i> <i>From Starting</i></p>
Low Alarm Enable	<p><input type="checkbox"/> = The Alarm is disabled. <input checked="" type="checkbox"/> = The <i>Low Alarm</i> activates when the measured quantity drops below the <i>Low Alarm</i> setting.</p>
Low Alarm Action	<p> NOTE: For details of these, see the section Error! Reference source not found. entitled <i>Alarm Types</i> in this document.</p> <p>Select the type of alarm required from the list: <i>Electrical Trip</i></p>
Low Pre-Alarm Enable	<p><input type="checkbox"/> = The Pre-Alarm is disabled. <input checked="" type="checkbox"/> = The <i>Low Pre-Alarm</i> is active when the measured quantity drops below the <i>Low Pre-Alarm Trip</i> setting. The <i>Low Pre-Alarm</i> is automatically reset when the measured quantity rises above the configured <i>Low Pre-Alarm Return</i> level.</p>
Low Alarm String	The text that is displayed on the module's LCD when the <i>Low Alarm</i> or <i>Low Pre-Alarm</i> activates.

Parameter descriptions are continued overleaf...

Editing the Configuration

Parameter	Description
High Pre-Alarm Enable	<input type="checkbox"/> = The Pre-Alarm is disabled. <input checked="" type="checkbox"/> = The <i>High Pre-Alarm</i> is active when the measured quantity rises above the <i>High Pre-Alarm Trip</i> setting. The <i>High Pre-Alarm</i> is automatically reset when the measured quantity falls below the configured <i>High Pre-Alarm Return</i> level.
High Alarm Enable	<input type="checkbox"/> = The Alarm is disabled. <input checked="" type="checkbox"/> = The <i>High Alarm</i> is active when the measured quantity rises above the <i>High Alarm</i> setting.
High Alarm Action	<div style="border: 3px double black; padding: 5px;"> <p> NOTE: For details of these, see the section Error! Reference source not found. entitled <i>Alarm Types</i> in this document.</p> </div> <p>Select the type of alarm required from the list: <i>Electrical Trip</i></p>
High Alarm String	The text that is displayed on the module's LCD when the <i>High Alarm</i> or <i>High Pre-Alarm</i> activates.

3.12.4 DSE2152 OUTPUT MODULES

Select the DSENet ID of the output expansion to be configured. The ID of the expansion input module is set by rotary decimal switch accessible under the removable cover of the device.



The following options are then shown:

2152 Expansion Enable

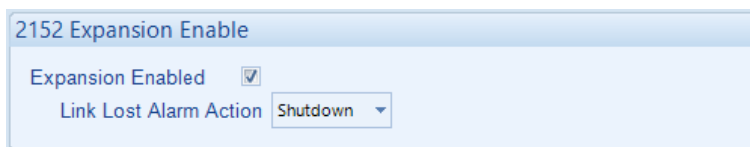

Parameter	Description
Expansion Enabled	<input type="checkbox"/> = The expansion module with the selected ID is not enabled. <input checked="" type="checkbox"/> = The expansion module with the selected ID is enabled. If the expansion module is not connected / detected by the module, the module generates an <i>Exp. Unit Failure</i> alarm with the configured <i>Link Lost Alarm Action</i> severity.
Link Lost Alarm Action	Select the type of alarm required from the list: Electrical Trip: Warning:

2152 Expansion Outputs

The *Expansion Unit* page is then subdivided into smaller sections. Select the required section with the mouse.

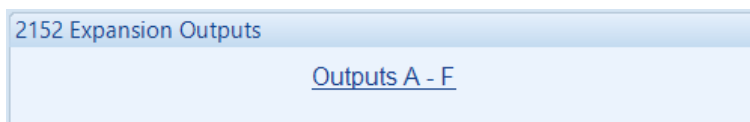

3.12.4.1 ANALOGUE OUTPUTS

Analogue Output A

Output Configuration

Output Name

Output Type

Source

Curve

Output Configuration

Output Configuration

Output Name

Parameter	Description
Output Name	Enter the <i>Output Name</i> , this text is shown on in the SCADA section when viewing the output.

Output Type

Output Type

Source

Curve

Click to edit the 'output curve.' See section entitled *Editing the Output Curve*.

Parameter	Description
Source	Select the parameter that is to be mapped to the analogue output.
Curve	Select the output type and curve from a pre-defined list or create a user-defined curve Current: for sensors with maximum range of 0 mA to 20 mA Voltage: for sensors with maximum range of 0 V to 10 V

3.12.4.2 CREATING / EDITING THE OUTPUT CURVE

While the *DSE Configuration Suite* holds specifications for the most used output ranges, occasionally it is required that the expansion module's output be connected to a nonstandard device. To aid this process, a curve editor is provided.

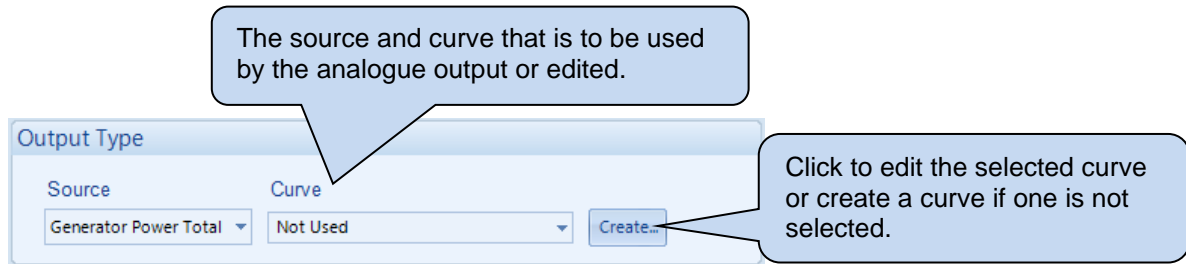

When creating a new sensor curve the measurement quantity and measured parameter are required.

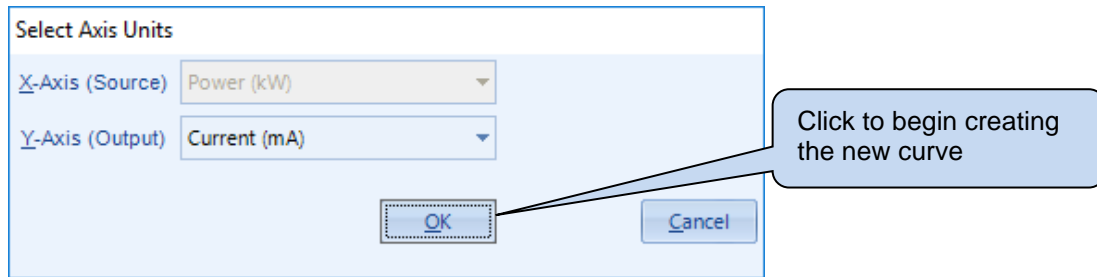

Parameter	Description
Y-Axis (Source)	The parameter measured by the DSE module that is to be mapped to the output.
X-Axis (Output)	Select the electrical quantity that the sensor outputs. Current (mA): For an output current within a range 0 mA to 20 mA Voltage (Volt): For an output voltage within a range of 0 V to 10 V

Curve creation / editor descriptions are continued overleaf...

Editing the Configuration

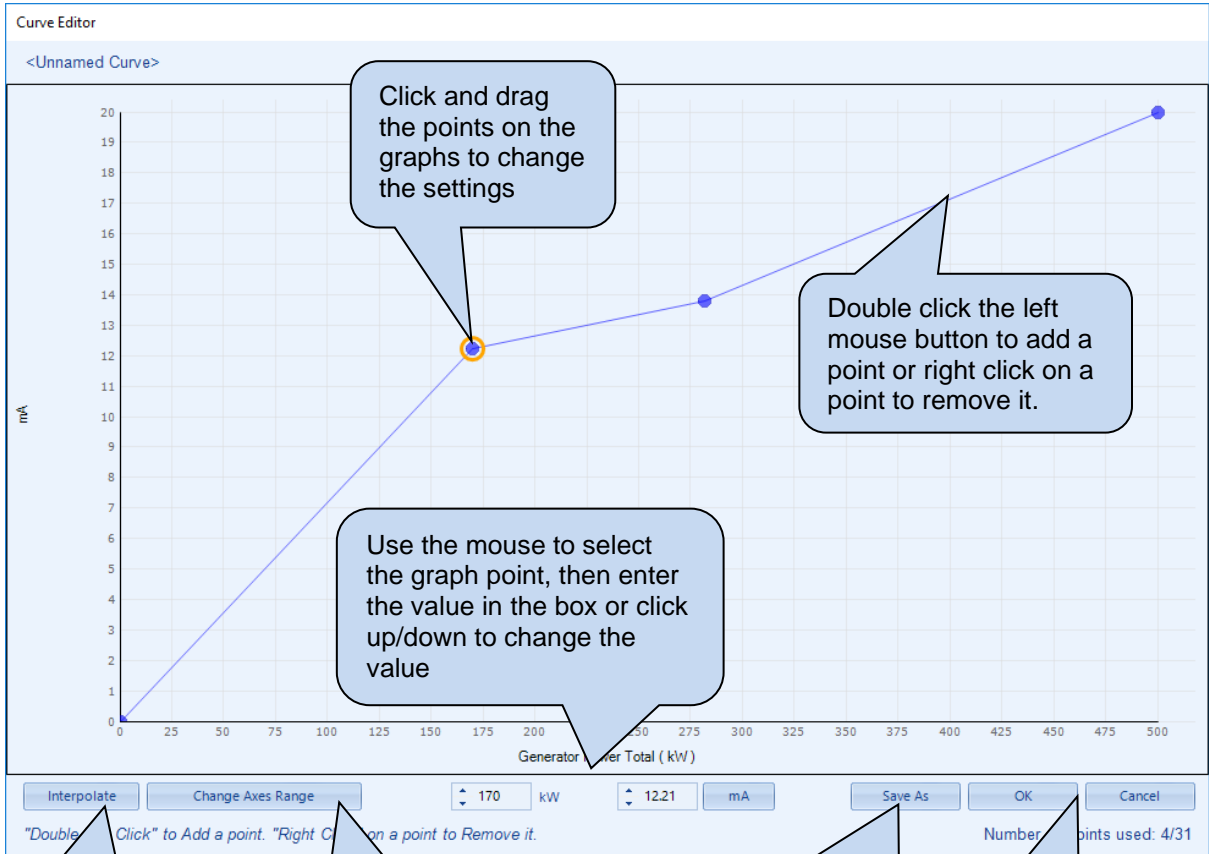

Click *Interpolate* then select two points as prompted to draw a straight line between

Click to change the range of the X and Y Axes of the graph and the level of open circuit

Click SAVE AS, a prompt to name the curve...

New Curve Name

Enter a name for the new curve

Click OK to save the curve.

Any saved curves become selectable in the *Output Type* selection list.

Click OK to accept the changes or CANCEL to ignore and lose the changes.

Hint: Deleting, renaming, or editing custom curves that have been added is performed in the main menu, select *Tools | Curve Manager*.

3.12.5 DSE2157 RELAY MODULES

Select the DSENet ID of the output expansion to be configured. The ID of the expansion module is set by rotary decimal switch accessible under the removable cover of the device.

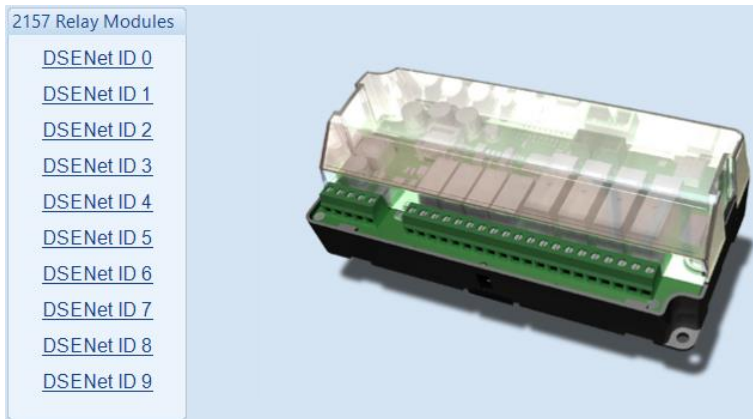

The following options are then shown:

2152 Expansion Enable

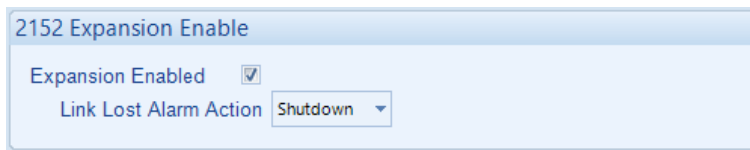

Parameter	Description
Expansion Enabled	<input type="checkbox"/> = The expansion module with the selected ID is not enabled. <input checked="" type="checkbox"/> = The expansion module with the selected ID is enabled. If the expansion module is not connected / detected by the module, the module generates an <i>Exp. Unit Failure</i> alarm with the configured <i>Link Lost Alarm Action</i> severity.
Link Lost Alarm Action	Select the type of alarm required from the list: Electrical Trip: Warning:

Relay Outputs (Normally Open / Changeover)

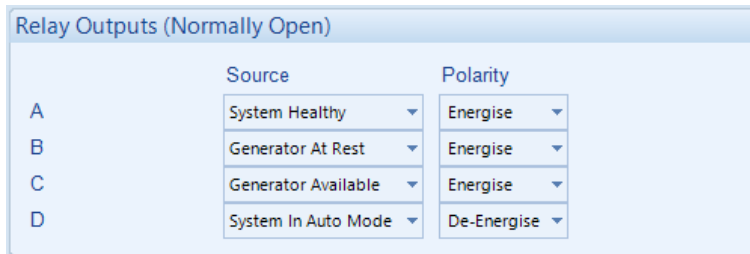

Parameter	Description
Source	Select the output source to control the state of the output See section Error! Reference source not found. entitled <i>Output Sources</i> for details of all available functions
Polarity	Select the digital input polarity: Energise: When the output source is true, the output activates. De-Energise: When the output source is true, the output deactivates.

3.12.6 DSE2548 ANNUNCIATOR MODULES

Select the DSENet ID of the LED expansion to be configured. The ID of the expansion input module is set by rotary decimal switch accessible on the rear of the device.



The following options are then shown:

2548 Expansion Enable

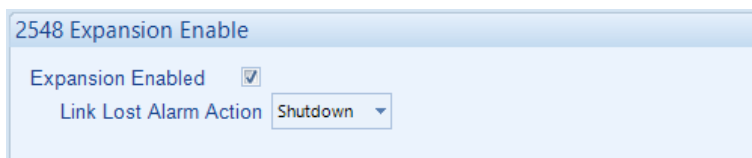

Parameter	Description
Expansion Enabled	<input type="checkbox"/> = The expansion module with the selected ID is not enabled. <input checked="" type="checkbox"/> = The expansion module with the selected ID is enabled. If the expansion module is not connected / detected by the module, the module generates an <i>Exp. Unit Failure</i> alarm with the configured <i>Link Lost Alarm Action</i> severity.
Link Lost Alarm Action	Select the type of alarm required from the list: Electrical Trip: Warning:

Sounder Configuration

Sounder Configuration

Follow main unit

Sounder enabled

Parameter	Description
Follow Main Unit	<input type="checkbox"/> = If the <i>mute / lamp test</i> button is pressed, other DSE2548 modules and the host module does not respond to this. <input checked="" type="checkbox"/> = If the <i>mute / lamp test</i> button is pressed, other DSE2548 modules configured to <i>Follow main unit</i> and the host module also lamp test / mute their alarm and vice-versa.
Sounder Enabled	<input type="checkbox"/> = The DSE2548 internal sounder does not annunciate on a fault condition becoming active. <input checked="" type="checkbox"/> = The DSE2548 internal sounder annunciates on a fault condition becoming active.

LED Indicators

LED	Description	State
A	System In Auto Mode	Unlit
B	Generator Load Inhibited	Lit
C	Combined Remote Start Request	Lit
D	Common Alarm	Lit
E	Not Used	Lit
F	Not Used	Lit
G	Not Used	Lit
H	Not Used	Lit

Annunciator Insert Card

Parameter	Description
Source	Select the output source to control the state of the output See section entitled <i>Output Sources</i> for details of all available functions
Polarity	Select the digital input polarity: Energise: When the output source is true, the output is Lit. De-Energise: When the output source is true, the output is Unlit.
Annunciator Insert Card	Allows the user to create and print the custom text insert cards for the LEDs.

3.12.7 BATTERY CHARGERS

Select the DSENet ID of the battery charger to be configured. The ID of the expansion module is set by configuration of the device.



The following options are then shown:

DSENet ID

DSENet ID 0

Enable

Link Lost Alarm Action Shutdown

Modbus Slave ID 11

Display Instrumentation

Charger Name Charger ID0

Parameter	Description
Enable	<input type="checkbox"/> = The battery charger with the selected ID is not enabled. <input checked="" type="checkbox"/> = The battery charger with the selected ID is enabled. If the expansion module is not connected / detected by the module, the module generates an <i>Exp. Unit Failure</i> alarm with the configured <i>Link Lost Alarm Action</i> severity.
Modbus Slave ID	The Slave ID used to address the battery charger via the host module's RS485 when using the host module as a MODBUS RTU pass through.
Display Instrumentation	<input type="checkbox"/> = The battery chargers' information is not shown on the host module's display. <input checked="" type="checkbox"/> = The battery charger information is shown on the host module's display.
Charger Name	Enter the <i>Charger Name</i> , this text is shown on the module display when viewing the battery charger instrumentation

Charger Warning Alarms

Charger Warning Alarms

Enable

Module Action Warning

Alarm String Charger ID0 Common Warning

Parameter	Description
Enable	<input type="checkbox"/> = The DSE module does not display any warning alarms from the battery charger. <input checked="" type="checkbox"/> = The DSE module displays warnings alarms from the battery charger with the configured action.
Alarm String	The text that is displayed on the module's LCD when the DSE module detects a warning fault from the battery charger.

3.13 ADVANCED

These settings are provided for *advanced* users only. Take care when changing these options and ensure you fully understand the consequences of any change made.

3.13.1 ADVANCED OPTIONS



3.13.1.1 OUT OF SYNC

During parallel operation, the phase of both supplies is monitored. Being in parallel means that this phase angle is zero degrees (0°).

If the angle exceeds the *Out of Sync Angle* for longer than the duration of the *Out of Sync Timer*, an electrical trip alarm is generated.

TROUBLESHOOTING

This section describes the most common causes for an *Out of Sync* alarm:

- The *Bus Sensing* connections have not been made between the bus and the DSE module, or the bus sensing fuses have blown or have been removed.
- The load switching device does not close quickly enough. Ensure the breaker closes within 100mS of receiving the close signal.
- The *Out of Sync* timer is set too low. If you raise this timer away from the factory setting of 200mS (0.2s), ensure you understand why you are raising it!
- Something external has caused the breaker to open or has prevented it from closing.
- The breaker wiring 'logic' may not be correct, causing the breaker to 'fire through,' where it triggers the close mechanism, but the breaker does not actually mechanically close, it re-opens again.

3.13.1.2 OTHER TIMERS

Options	Description
Synchronisation Delay	Delays the synchronising process to allow the buses to stabilise.

3.13.2 PLC

NOTE: For further details and instructions on the PLC Editor, refer to DSE Publication: 057-314 Advanced PLC Software Manual which is found on our website: www.deepseaelectronics.com

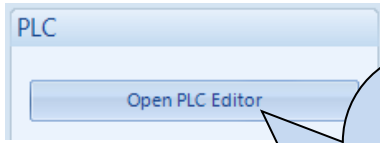

Click to open the *PLC Editor*, then the *PLC Editor* opens as shown below.

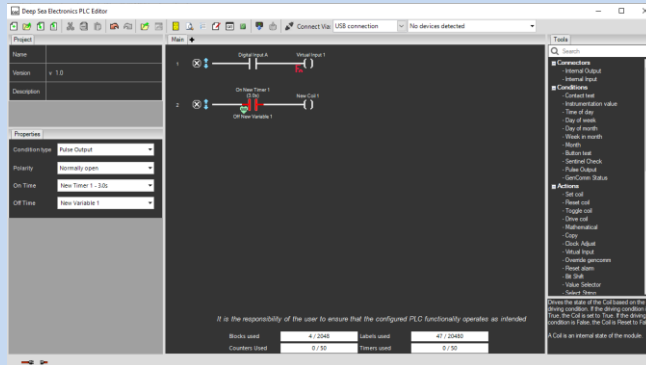

3.13.3 CONFIGURABLE GENCOMM PAGES 166 TO 169

[Configurable Gencomm Pages](#)

[Page 166](#)

[Page 167](#)

[Page 168](#)

[Page 169](#)

For advanced MODBUS users of the controller, configurable Gencomm pages are available. The intention is to allow the user to create personal collections of data in subsequent registers to minimise the number of MODBUS reads required by the master, and hence speed up data collection.

All configurable Gencomm registers are 32-bit unsigned format.

Gencomm Page 166			
Register	Value	Register	Value
0-1	<Not Used>	64-65	<Not Used>
2-3	<Not Used>	66-67	<Not Used>
4-5	<Not Used>	68-69	<Not Used>
6-7	<Not Used>	70-71	<Not Used>
8-9	<Not Used>	72-73	<Not Used>
10-11	<Not Used>	74-75	<Not Used>
12-13	<Not Used>	76-77	<Not Used>
14-15	<Not Used>	78-79	<Not Used>
16-17	<Not Used>	80-81	<Not Used>
18-19	<Not Used>	82-83	<Not Used>
20-21	<Not Used>	84-85	<Not Used>
22-23	<Not Used>	86-87	<Not Used>
24-25	<Not Used>	88-89	<Not Used>
26-27	<Not Used>	90-91	<Not Used>
28-29	<Not Used>	92-93	<Not Used>
30-31	<Not Used>	94-95	<Not Used>
32-33	<Not Used>	96-97	<Not Used>
34-35	<Not Used>	98-99	<Not Used>
36-37	<Not Used>	100-101	<Not Used>
38-39	<Not Used>	102-103	<Not Used>
40-41	<Not Used>	104-105	<Not Used>
42-43	<Not Used>	106-107	<Not Used>
44-45	<Not Used>	108-109	<Not Used>
46-47	<Not Used>	110-111	<Not Used>
		128-129	<Not Used>
		130-131	<Not Used>
		132-133	<Not Used>
		134-135	<Not Used>
		136-137	<Not Used>
		138-139	<Not Used>
		140-141	<Not Used>
		142-143	<Not Used>
		144-145	<Not Used>
		146-147	<Not Used>
		148-149	<Not Used>
		150-151	<Not Used>
		152-153	<Not Used>
		154-155	<Not Used>
		156-157	<Not Used>
		158-159	<Not Used>
		160-161	<Not Used>
		162-163	<Not Used>
		164-165	<Not Used>
		166-167	<Not Used>
		168-169	<Not Used>
		170-171	<Not Used>
		172-173	<Not Used>
		174-175	<Not Used>
		192-193	<Not Used>
		194-195	<Not Used>
		196-197	<Not Used>
		198-199	<Not Used>
		200-201	<Not Used>
		202-203	<Not Used>
		204-205	<Not Used>
		206-207	<Not Used>
		208-209	<Not Used>
		210-211	<Not Used>
		212-213	<Not Used>
		214-215	<Not Used>
		216-217	<Not Used>
		218-219	<Not Used>
		220-221	<Not Used>
		222-223	<Not Used>
		224-225	<Not Used>
		226-227	<Not Used>
		228-229	<Not Used>
		230-231	<Not Used>
		232-233	<Not Used>
		234-235	<Not Used>
		236-237	<Not Used>
		238-239	<Not Used>

The configurable MODBUS pages are:

Page	Hex Address	Decimal Address
166	A600	42496
167	A700	42752
168	A800	43008
169	A900	43264

Example of Gencomm Page Configuration:

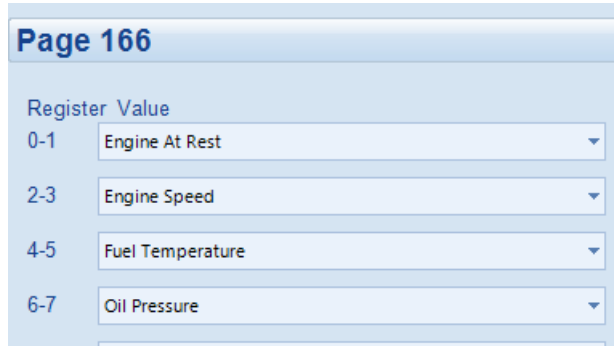

The screenshot shows a configuration window titled "Page 166". It contains a table with two columns: "Register" and "Value". The "Register" column has four entries: "0-1", "2-3", "4-5", and "6-7". The "Value" column has four corresponding entries: "Engine At Rest", "Engine Speed", "Fuel Temperature", and "Oil Pressure". Each entry in the "Value" column is displayed within a dropdown menu.

Register	Value
0-1	Engine At Rest
2-3	Engine Speed
4-5	Fuel Temperature
6-7	Oil Pressure

The register address is obtained from the formula: register address=page_number*256+register_offset.

To read the *Engine Speed* from the above register, the MODBUS master device needs to read the data in two registers and then combine the data from the Most Significant Bit and the Least Significant Bit.

MSB address in Decimal = $(166 * 256) + 2 = 42498$

LSB address in Decimal = $(166 * 256) + 3 = 42499$

4 SCADA

SCADA stands for **S**upervisory **C**ontrol **A**nd **D**ata **A**cquisition and is provided both as a service tool and as a means of monitoring / controlling the Bus Tie.

As a service tool, the SCADA pages is to check the operation of the controller's inputs and outputs as well as checking the Bus Tie operating parameters.

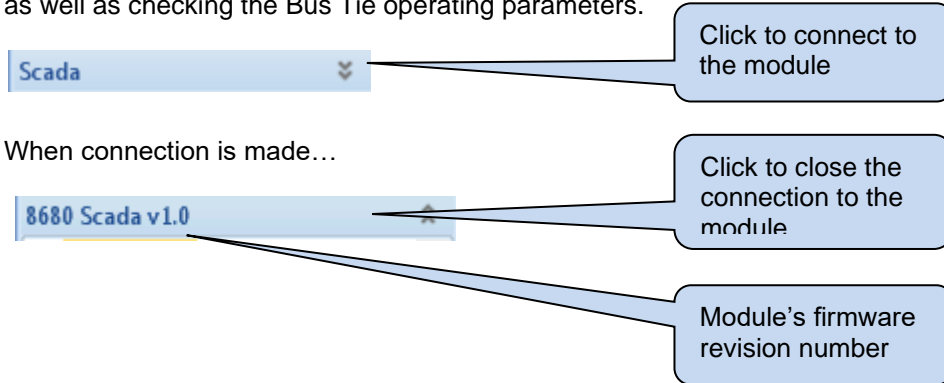

The SCADA page is subdivided into smaller sections. Select the required section with the mouse.

NOTE: The SCADA sections will appear depending on how the module is configured.



4.1 SYSTEM IDENTITY

Shows the module's current settings for *Site ID* and *genset ID*.

This information is particularly helpful when the current connection is made remotely by modem or internet for example or when the connected set is one of several sets on an RS485 data link.

System Identity
Site Identity
System Identity

4.2 MIMIC

This section provides a mimic of the module's fascia and allows the operator to change the control mode of the module.

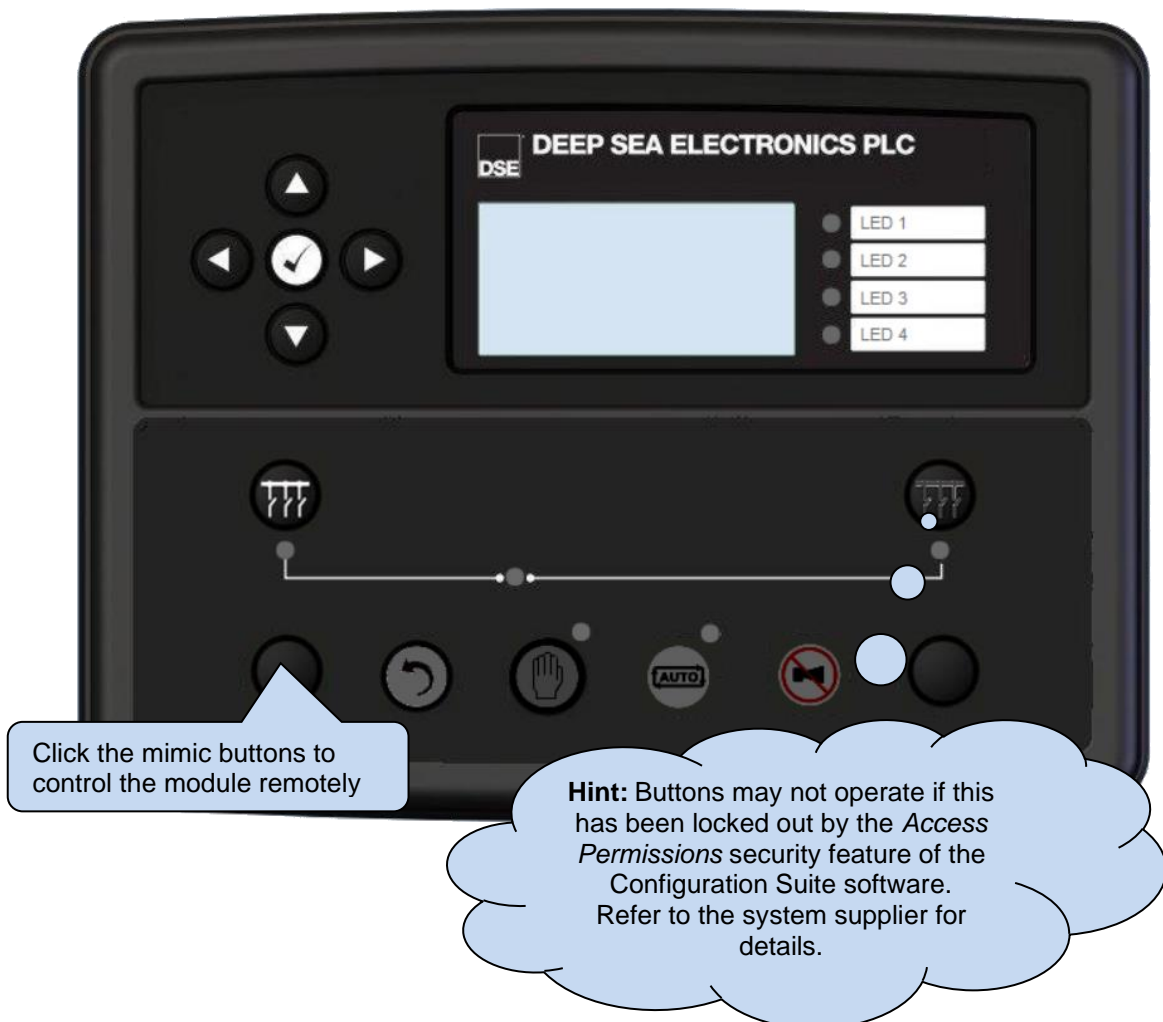

4.3 DIGITAL INPUTS

This section displays the status of the module's digital inputs and their configured functions. For further details on how to configure these items, refer to section 3.4 entitled *Digital Inputs*.

The screenshot shows a 'Digital Inputs' panel with the following data:

Label	Active	Open / Closed
A Bus Closed Auxiliary	Green circle	Switch icon
B Digital Input B	Green circle	Switch icon
C Digital Input C	Green circle	Switch icon
D Digital Input D	Green circle	Switch icon
E Digital Input E	Green circle	Switch icon
F Digital Input F	Green circle	Switch icon
G Digital Input G	Green circle	Switch icon
H Digital Input H	Green circle	Switch icon
I Digital Input I	Green circle	Switch icon
J Digital Input J	Green circle	Switch icon
K Digital Input K	Green circle	Switch icon
L Digital Input L	Green circle	Switch icon
Emergency Stop		Red push-button icon

Callout 1: Shows if the input channel is active or not. (Points to the Active column)

Callout 2: State of the input (open or closed to battery negative) (Points to the Open / Closed column)

4.4 DIGITAL OUTPUTS

This section displays the status of the module's digital outputs and their configured. For further details on how to configure these items, refer to section 3.5.1 entitled Digital Outputs.

Digital Outputs (Volts Free)		Active	Open / Closed
C (N/C)	Digital Output 9 (Mains Parallel)	●	⏏
D	Digital Output 10 (Bus)	●	⏏

Digital Outputs (DC Supply Out)		Active	Open / Closed
E	Digital Output 1	●	⏏
F	Digital Output 2	●	⏏
G	Digital Output 3	●	⏏
H	Digital Output 4	●	⏏
I	Digital Output 5	●	⏏
J	Digital Output 6	●	⏏
K	Digital Output 7	●	⏏
L	Digital Output 8	●	⏏

State of the output (open or closed)

Shows if the output channel is active or not.

4.5 VIRTUAL LEDS

Shows the state of the *virtual LEDs*. These LEDs are not fitted to the module or expansion modules, they are not physical LEDs. They are provided to show status and appear only in the SCADA section of the configuration suite or read by third party PLC or Building Management Systems (for example) using the ModBus RTU protocol.

Virtual LEDs

LED 1-10 Status

Common Alarm		Active
Not Used		●
Not Used		●
Not Used		●
Not Used		●
Not Used		●
Not Used		●
Not Used		●
Not Used		●
Not Used		●
Not Used		●
Not Used		●

Shows what the Virtual LED is configured for (shows *Not Used* if not configured)

Shows if the Virtual LED is active or not

LED 11-20 Status

		Active
LED 11	Not Used	●
LED 12	Not Used	●
LED 13	Not Used	●
LED 14	Not Used	●
LED 15	Not Used	●
LED 16	Not Used	●
LED 17	Not Used	●
LED 18	Not Used	●
LED 19	Not Used	●
LED 20	Not Used	●

4.6 POWER

This section displays the module's measurement of the power the bus tie is transferring.



Parameter	Description
Load Level Minimum Power to Open	Minimum power to open - The threshold (when no CTS are fitted) that the bus tie will ramp to the kW Ramp Off target. For example, if the target power level is 30kW and the minimum power level to open is 3kW and the left side of the bus tie is being controlled during ramping off, then the bus tie will open if the shared power level reported by the AMSC is between 27kW and 33kW.
Load Capacity Required	The size of the load that the bus tie is switching and how much power needs to be available before the load is closed (to avoid overloading the generators).

NOTE: This option is only available when the module is configured as a load switch.

NOTE: The time that the bus tie will wait for this capacity to become available is controlled by the timer "Capacity Available Delay" which is in the configuration on the Timers / Load Timers page in section 3.6.1.

4.7 LEFT BUS

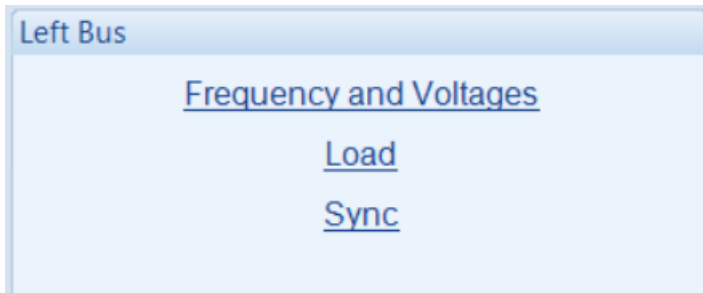

4.7.1 FREQUENCY AND VOLTAGES

This section displays the modules measurement of the Left Bus frequency, Phase Rotation, Phase To Neutral Voltages, Currents and Sets On Load

Frequency			
0.0 Hz			
Phase Rotation			
Indeterminate			
Phase To Neutral Voltages			
L1 - N	L2 - N	L3 - N	
0.0 V	0.0 V	0.0 V	
Phase To Phase Voltages			
L1 - L2	L2 - L3	L3 - L1	
0.0 V	0.0 V	0.0 V	
Current			
L1	L2	L3	
0.0 A	0.0 A	0.0 A	
Earth Current			
0.0 A			
Sets On Load			
0			

4.7.2 LOAD

This section displays the modules Left Bus Derived Instrumentation and Ramp Off Target

Bus Derived Instrumentation

Watts 0.00 kW	VAr 0.0 kVAr
------------------	-----------------

Ramp Off Target

kW	▲ ▼	kW	<input type="text"/>	Reset
kVAr	▲ ▼	kVAr	<input type="text"/>	Reset

Ramp Rates

Ramp Up Rate	3.0 %	<input type="range"/>	3.0 %
Ramp Down Rate	3.0 %	<input type="range"/>	3.0 %

Parameter	Description
Ramp Off Target	The kW and Kvar target settings when no CTs are fitted. The kW and KVAR power levels from either side of the bus are read (left or right depending on which side the tie is controlling the generators to ramp the power) before opening the breaker.
Ramp Rates	The rate at which power is increased (ramped up rate) when the bus tie closes. The rate at which power is decreased (ramped down rate) when the bus tie opens.

4.7.3 SYNC

This section displays the modules Frequency Synchroniser, Load Share and Reactive Load Control.

Frequency Synchroniser

Slip Frequency	0.10 Hz	<input type="range"/>	0.10 Hz
----------------	---------	-----------------------	---------

4.8 RIGHT BUS

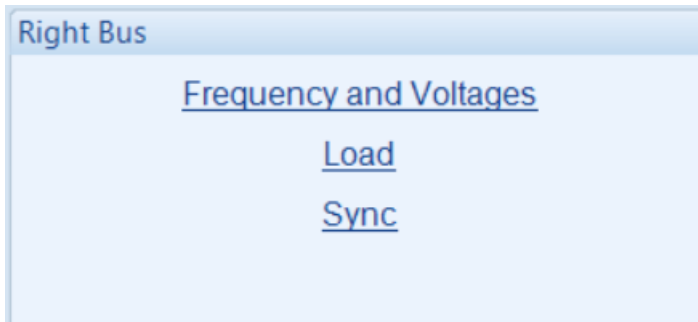

4.8.1 FREQUENCY AND VOLTAGES

This section displays the modules measurement of the Mains frequency, Phase Rotation, Phase To Neutral Voltages and Sets On Load

Frequency			
0.0 Hz			
Phase Rotation			
Indeterminate			
Phase To Neutral Voltages			
L1 - N	L2 - N	L3 - N	
0.0V	0.0V	0.0V	
Phase To Phase Voltages			
L1 - L2	L2 - L3	L3 - L1	
0.0V	0.0V	0.0V	
Current			
L1	L2	L3	
0.0A	0.0A	0.0A	
Earth Current			
0.0A			
Sets On Load			
0			

4.8.2 LOAD

This section displays the modules Bus Derived Instrumentation and Ramp Off Target

Bus Derived Instrumentation

Watts 0.00 kW	VAr 0.0 kVAr
------------------	-----------------

Ramp Off Target

kW	▲ ▼	kW	<input type="text"/>	Reset
kVAr	▲ ▼	kVAr	<input type="text"/>	Reset

Ramp Rates

Ramp Up Rate	3.0 %	<input type="range" value="3.0"/>	3.0 %
Ramp Down Rate	3.0 %	<input type="range" value="3.0"/>	3.0 %

Parameter	Description
Ramp Off Target	The kW and Kvar target settings when no CTs are fitted. The kW and KVAR power levels from either side of the bus are read (left or right depending on which side the tie is controlling the generators to ramp the power) before opening the breaker.
Ramp Rates	The rate at which power is increased (ramped up rate) when the bus tie closes. The rate at which power is decreased (ramped down rate) when the bus tie opens.

4.8.3 SYNC

This section displays the modules Frequency Synchroniser.

Frequency Synchroniser

Slip Frequency	0.10 Hz	<input type="range" value="0.10"/>	0.10 Hz
----------------	---------	------------------------------------	---------

4.9 AMSC LINK

AMSC Link

Left Bus		Right Bus	
Sets On The Bus	0	Sets On The Bus	0
Mains Controllers On The Bus	0	Mains Controllers On The Bus	0
Bus Tie Controllers On The Bus	1	Bus Tie Controllers On The Bus	1
Group Controllers On The Bus	0	Group Controllers On The Bus	0
Segment Number	1	Segment Number	2

Bus Tie

AMSC ID	2	<input type="text" value="2"/>	<input type="button" value="Set"/>	
User Priority (for master arbitration)		<input type="text" value="1"/>	<input type="button" value="Set"/>	

Commissioning Screen

Enable ●

Parameter	Description
AMSC ID	The DSE module uses the <i>AMSC ID</i> number configured in this section up to a maximum of 64.
User Priority	The Master Arbitration Priority, helps determine which master can take control of a bus.
Commissioning Screen	<input type="checkbox"/> = Commissioning screen is disabled. <input checked="" type="checkbox"/> = Commissioning screen is enabled.

▲ NOTE: The module with the lowest *User Priority* number has the highest priority. If more than one module has the same *User Priority*, then the *AMSC ID* is used to decide the priority instead.

4.10 ALARMS

This section displays the alarms that are currently active on the module.

For information regarding alarm severity, refer to section **Error! Reference source not found.** entitled *Alarm Types* within this document.

Alarms

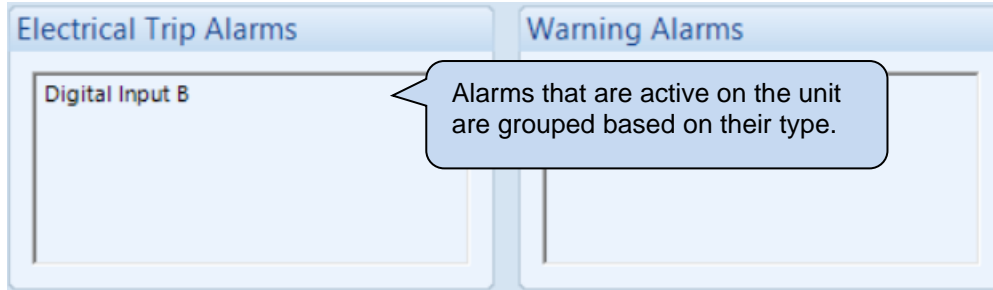

4.11 STATUS

This section displays the status information about the module.

The status panel is titled "Status" and is divided into several sections:

- Plant Battery Voltage:** 26.2 V DC
- Supervisor State:** Open Request
- Load Switching State:** Bus Tie - Electrical Trip
- Heater Fitted:** Heater Fitted
- Application:** (Empty)
- Software Version:**
 - Main version: 1.0.16
 - Bootloader: 3.1.1
 - Co-Processor: 1.3.2
 - Bootstrap: 3.1.3
- Module ID:** 1BAD1DEA
- Mode:** Represented by a hand icon.

4.12 EVENT LOG

This section displays the events which are recorded with the module's event log along with the time, date, and engine hours in which they occurred. For further details on how what events are recorded, refer to section 3.3.3 entitled *Event Log* within this document.

#	Date	Time	Hours Run	Event	Details
1	20/05/2022	13:13:05	0:00	Bus	Bus on load
2	20/05/2022	13:13:05	0:00	Restart	Power Up
3	19/05/2022	13:49:44	0:00	ETrip	Bus Breaker Failed To Open
4	19/05/2022	13:48:25	0:00	ETrip	Bus Breaker Failed To Open
5	19/05/2022	09:56:25	0:00	ETrip	Bus Breaker Failed To Open
6	19/05/2022	09:56:10	0:00	Bus	Bus on load
7	19/05/2022	09:56:10	0:00	Restart	Power Up
8	19/05/2022	09:55:47	0:00	ETrip	Bus Breaker Failed To Open
9	19/05/2022	09:54:39	0:00	Warning	AMSC Data Error Port 1
10	19/05/2022	09:54:32	0:00	Warning	AMSC Data Error Port 1
11	19/05/2022	08:34:24	0:00	Bus	Bus on load
12	19/05/2022	08:34:24	0:00	ETrip	D/I B "Alarm Mute"
13	19/05/2022	08:34:24	0:00	Restart	Power Up
14	18/05/2022	12:02:41	0:00	Bus	Bus on load
15	18/05/2022	12:02:41	0:00	ETrip	D/I B "Alarm Mute"
16	18/05/2022	12:02:41	0:00	Restart	Power Up
17	18/05/2022	10:12:04	0:00	ETrip	D/I B "Alarm Mute"
18	18/05/2022	08:22:54	0:00	ETrip	D/I B "Alarm Mute"
19	18/05/2022	07:54:29	0:00	Bus	Bus on load
20	18/05/2022	07:54:29	0:00	ETrip	D/I B "Alarm Mute"
21	18/05/2022	07:54:29	0:00	Restart	Power Up
22	04/05/2022	07:23:27	0:00	Bus	Bus on load
23	04/05/2022	07:23:27	0:00	ETrip	D/I B "Alarm Mute"
24	04/05/2022	07:23:27	0:00	Restart	Power Up
25	03/05/2022	12:56:44	0:00	ETrip	D/I B "Alarm Mute"
26	02/06/2000	19:00:40	0:00	Bus	Bus on load

Export to Excel
Export to CSV
Export to PDF
Print event log

Click to save the log to an Excel or csv file for use in an external spreadsheet

Click to save the log to a pdf (Adobe Acrobat) file.

Click to print the log

4.13 REMOTE CONTROL

This section displays a series of output sources that are controlled by remote control in the SCADA section of the software. They are used to control external circuits or can be used in the control logic section of the configuration suite.

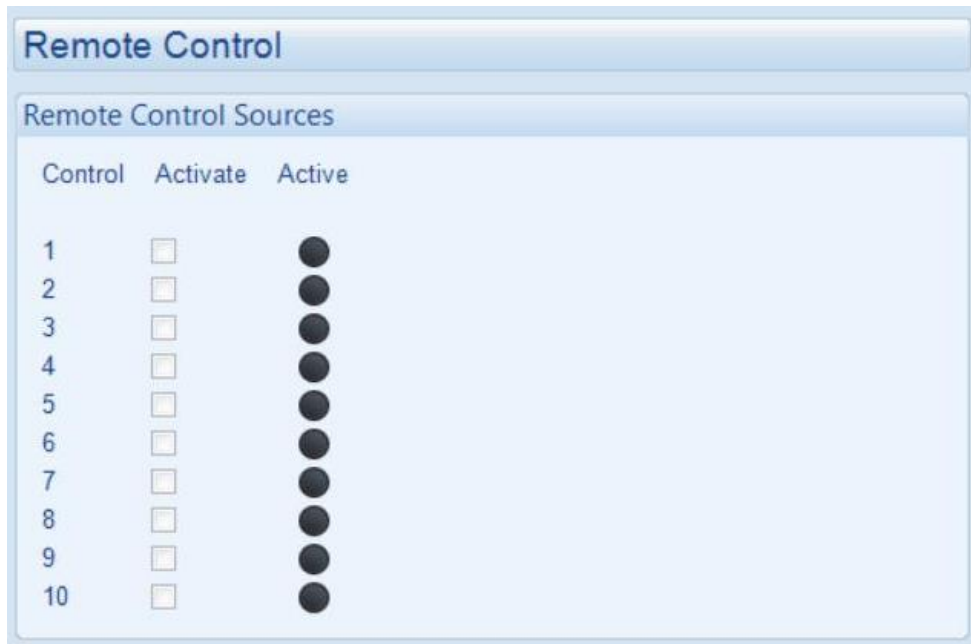

4.14 MAINTENANCE

The *Maintenance* section is subdivided into smaller sections. Select the required section with the mouse.

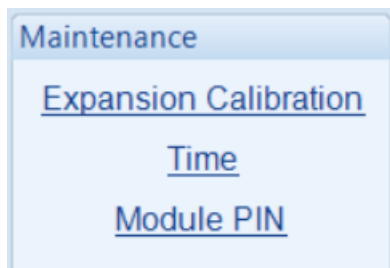

4.14.1 EXPANSION CALIBRATION

This section allows the analogue sensor inputs of the DSE2130 and DSE2131 expansion modules to be calibrated to remove inaccuracies caused by the tolerance of the sensor devices. While the engine is running, the instruments are calibrated, and reference needs to be made to a third-party accurate sensing device to ensure accurate recalibration.



4.14.2 DATE AND TIME

This section allows the date and time to be adjusted on the controller.

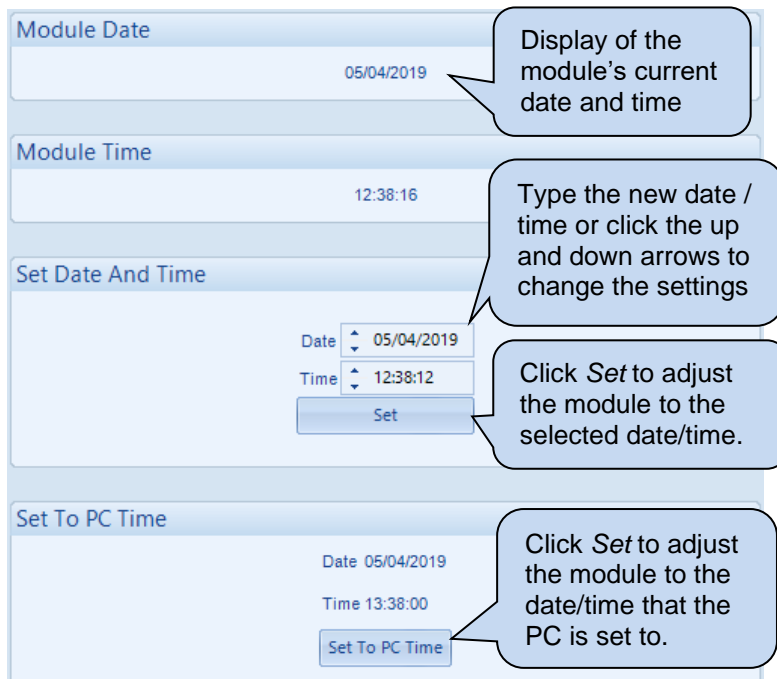

4.14.3 MODULE PIN

! CAUTION!: If the module PIN is lost or forgotten, it is no longer possible to access or make changes to the module!

This section allows the user to configure a PIN (Personal Identification Number) within the module. This PIN must be entered to access the modules *Main Front Panel Configuration Editor* or, when writing a configuration / changing a value in SCADA using the DSE Configuration Suite PC Software.

Module Access Password

Password

Confirmation

Warning - care should be taken when adjusting these controls.
If the password is lost or forgotten, it will not be possible to access the module.

Set PIN

Enter the desired PIN and confirmation

Click to set the PIN within the module.

4.15 COMMUNICATIONS INFORMATION

This section displays the information about the configuration of the module's ethernet port. For further details on how to configure the module's ethernet port, refer to section 3.10 entitled *Ethernet Port* within this document.

IP address 192 . 168 . 1 . 100	MAC Address E8 : A4 : C1 : 2 : 8D : 7
Subnet Mask 255 . 255 . 255 . 0	DNS 8 . 8 . 8 . 8
Host DSE Host	MODBUS Preferred IP Address 192 . 168 . 1 . 99
Domain DSE Module	MODBUS Connection Port 502
Gateway 192 . 168 . 1 . 1	DHCP Off
	TCP Vendor DSE Vender

4.16 DATA LOG

This section displays and temporarily records the instruments configured within the module's *Data Logging* facility to the PC. The data which is temporarily recorded is only for the duration in which the *Data Log* section is viewed. For further details on how to configure these items, refer to section 3.3.4 entitled *Data Logging* within this document.

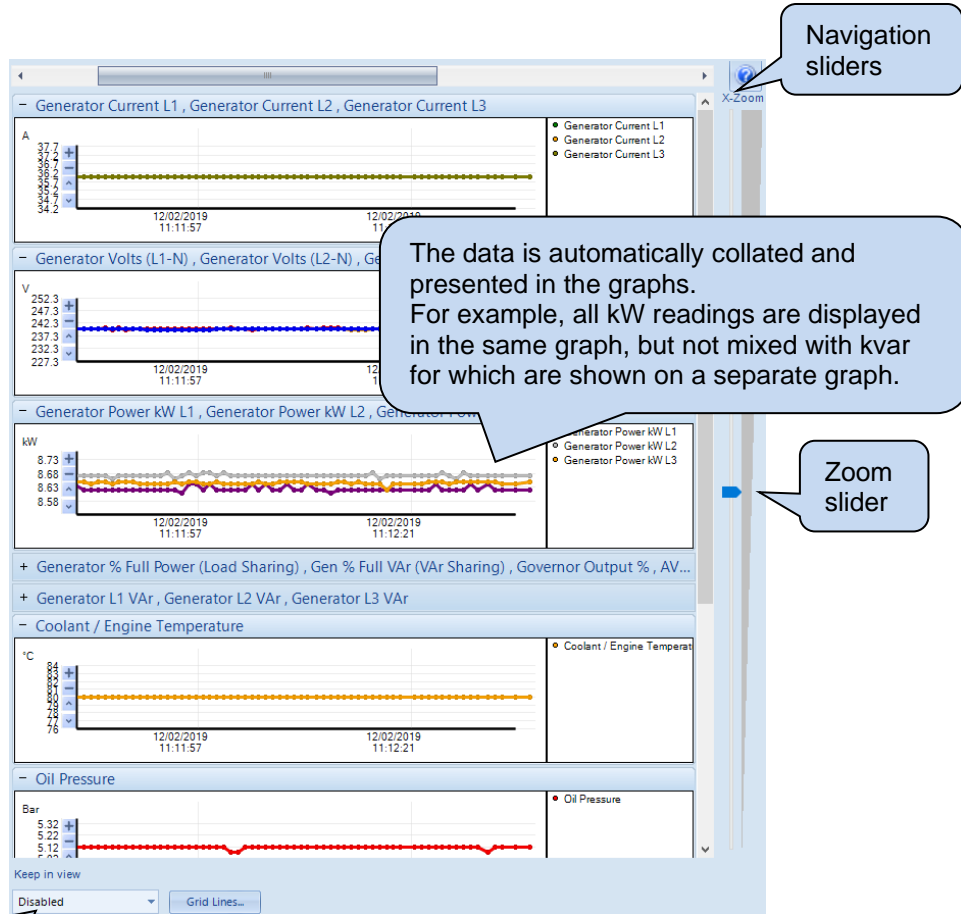

Navigation sliders

The data is automatically collated and presented in the graphs. For example, all kW readings are displayed in the same graph, but not mixed with kVar for which are shown on a separate graph.

Zoom slider

Selects the timescale of the displayed graphs. Scroll bars on the graph's 'x' axis is also used to scroll the graph backwards and forwards in time.

4.16.1 DATA LOG STATUS

This section displays the information module's *Data Logging* function. *For further details on how to configure the module's Data Logging function, refer to section 3.3.4 entitled Data Logging within this document.*

Internal Memory Capacity 2048 kB	Data Logging Status Logging
Remaining Data Log Memory Space remaining in Internal memory: 2032 kB	Data Log Mode Keep New
Remaining Data Log Time 7h 30m	USB Drive Status Not Fitted
Total Log Pages Available 128	Data Log Destination Internal
Current Page Usage 4.473 kB	

4.17 EXPANSION

The *Expansion* page is subdivided into smaller sections. Select the required section with the mouse.

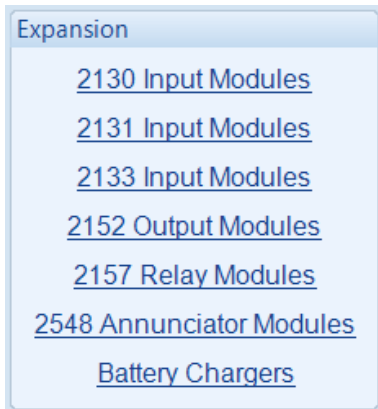

The selected section displays the status of the expansion module's inputs/outputs/LEDs etc and the functions they are configured for. *For further details on how to configure these items, refer to section 3.12 entitled Expansion in the Edit Config section for more information. An example status of a DSE2157 Output Expansion is shown below.*

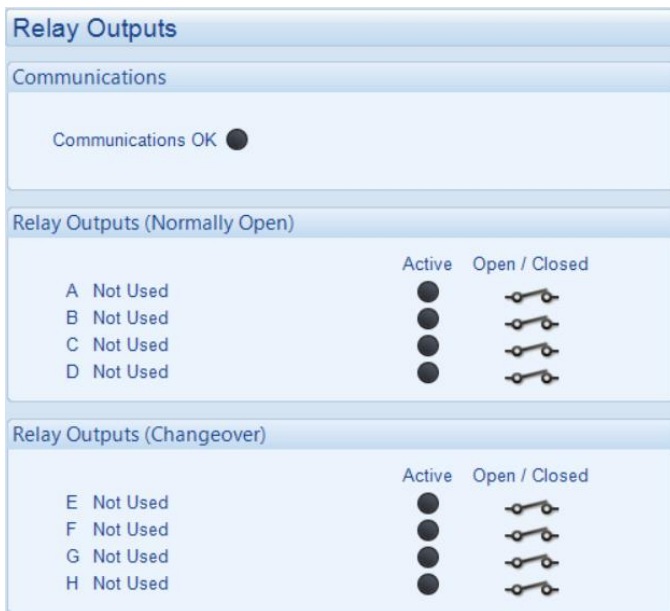

5 ALARM TYPES

The protection included with the DSE control modules provides increasing levels of notification, depending upon the severity of the situation:

Alarm type	Description
Indication	No audible alarm or common warning signal occurs. <i>Indication</i> alarms are only used to illuminate indicators or to activate outputs.
Warning	Audible alarm and common alarm signal are generated. The set continues to run. <i>Warning alarms</i> are used to draw the operator's attention to a minor issue or to a problem that may escalate to an Electrical Trip.
Electrical Trip	Audible alarm and common alarm signal are generated. <i>Electrical Trip alarms</i> are serious issues that require the set to be taken off load. As the name implies, this is often electrical faults that occur 'after' the load breaker.

6 ALARM ARMING

The protections on the DSE module are active during their configured *Alarm Arming* setting. The table below shows the timing segment for the different *Alarm Arming* options with regards to the generator status.

6.1 NEVER

The protection is never active on the controller. This is used to disable the protection.

6.2 ALWAYS

The protection is always active on the controller. This is used to constantly monitor statuses such as a fuel level switch irrespective of the engine running state.

This page is intentionally left blank