



# **DEEP SEA ELECTRONICS**

## **DSEG8600 Configuration Suite**

### **PC Software Manual**

**Document Number: 057-322**

Author: Ian Roberts





**Deep Sea Electronics Ltd.**

Highfield House  
 Hunmanby  
 North Yorkshire  
 YO14 0PH  
 England

**Sales Tel:** +44 (0) 1723 890099

**E-mail:** [sales@deepseaelectronics.com](mailto:sales@deepseaelectronics.com)

**Website:** [www.deepseaelectronics.com](http://www.deepseaelectronics.com)

**DSEG8600 Configuration Suite PC Software Manual**

© Deep Sea Electronics Ltd.

All rights reserved. No part of this publication may be reproduced in any material form (including photocopying or storing in any medium by electronic means or other) without the written permission of the copyright holder except in accordance with the provisions of the Copyright, Designs and Patents Act 1988.

Applications for the copyright holder’s written permission to reproduce any part of this publication must be addressed to Deep Sea Electronics Ltd. at the address above.

The DSE logo and the names DSEGenSet®, DSEATS®, DSEPower® and DSEControl® are UK registered trademarks of Deep Sea Electronics Ltd.

Any reference to trademarked product names used within this publication is owned by their respective companies.

Deep Sea Electronics Ltd. reserves the right to change the contents of this document without prior notice.

Amendments Since Last Publication

Amd. No.	Config Suite Version No	Comments	Date
1	1.0	Initial release	28/10/2022
2	3.30	Added VDE and IEEE Fault Ride Through Specification	15/01/2025

Typeface: The typeface used in this document is *Arial*. Care must be taken not to mistake the upper-case letter I with the numeral 1. The numeral 1 has a top serif to avoid this confusion.

## TABLE OF CONTENTS

Section	Page
<b>1 INTRODUCTION.....</b>	<b>8</b>
<b>1.1 CLARIFICATION OF NOTATION.....</b>	<b>9</b>
<b>1.2 GLOSSARY OF TERMS.....</b>	<b>9</b>
<b>1.3 BIBLIOGRAPHY.....</b>	<b>12</b>
1.3.1 INSTALLATION INSTRUCTIONS.....	12
1.3.2 MANUALS.....	13
1.3.3 TRAINING GUIDES.....	14
1.3.4 THIRD PARTY DOCUMENTS.....	15
<b>1.4 INSTALLATION AND USING THE DSE CONFIGURATION SUITE SOFTWARE.....</b>	<b>15</b>
<b>2 GENERAL CONTROLS.....</b>	<b>16</b>
<b>2.1 USER CONTROLS.....</b>	<b>16</b>
<b>3 EDITING THE CONFIGURATION.....</b>	<b>18</b>
<b>3.1 SCREEN LAYOUT.....</b>	<b>18</b>
<b>3.2 APPLICATION.....</b>	<b>19</b>
<b>3.3 MODULE.....</b>	<b>22</b>
3.3.1 MODULE OPTIONS.....	22
3.3.2 MISCELLANEOUS OPTIONS.....	25
3.3.3 CONFIGURABLE FRONT PANEL EDITOR.....	30
3.3.4 CONFIGURABLE INSTRUMENTATION DISPLAY.....	31
3.3.5 EVENT LOG.....	32
3.3.6 DATA LOGGING.....	35
3.3.6.1 CONFIGURATION.....	36
3.3.6.2 OPTIONS.....	37
<b>3.4 INPUTS.....</b>	<b>38</b>
3.4.1 ANALOGUE INPUT CONFIGURATION.....	38
3.4.2 ANALOGUE INPUTS.....	41
3.4.2.1 CREATING / EDITING THE SENSOR CURVE.....	45
3.4.3 DIGITAL INPUTS.....	48
3.4.3.1 DIGITAL INPUTS.....	48
3.4.3.2 ANALOGUE INPUTS.....	50
3.4.3.3 INPUT FUNCTIONS.....	51
3.4.4 VIRTUAL INPUTS.....	59
3.4.4.1 VIRTUAL INPUTS.....	59
<b>3.5 OUTPUTS.....</b>	<b>61</b>
3.5.1 DIGITAL OUTPUTS.....	61
3.5.2 GOVERNOR ANALOGUE OUTPUT.....	62
3.5.3 AVR ANALOGUE OUTPUT.....	63
3.5.4 VIRTUAL LEDS.....	64
3.5.5 OUTPUT SOURCES.....	65
3.5.5.1 ALARMS.....	65
3.5.5.2 CONTROL.....	73
3.5.5.3 STATUS.....	78
<b>3.6 TIMERS.....</b>	<b>84</b>
3.6.1 START TIMERS.....	84
3.6.2 LOAD / STOPPING TIMERS.....	86
3.6.3 MODULE TIMERS.....	89
<b>3.7 GENERATOR.....</b>	<b>90</b>
3.7.1 GENERATOR OPTIONS.....	91
3.7.2 GENERATOR RATING.....	93
3.7.3 GENERATOR DE-RATE.....	94
3.7.4 GENERATOR VOLTAGE.....	95
3.7.5 GENERATOR SEQUENCE ALARMS.....	98
3.7.6 GENERATOR FREQUENCY.....	101
3.7.7 GENERATOR CURRENT.....	104

3.7.7.1	GENERATOR CURRENT OPTIONS .....	104
3.7.7.2	GENERATOR CURRENT ALARMS .....	105
3.7.7.2.1	DEFAULT CURRENT PROTECTION TRIPPING CHARACTERISTICS .....	116
3.7.8	GENERATOR POWER .....	118
3.7.8.1	OVERLOAD PROTECTION .....	119
3.7.8.2	LOAD CONTROL .....	119
3.7.8.3	REVERSE POWER .....	121
3.7.8.4	LOW LOAD .....	121
3.7.9	SYNCHRONISING .....	122
3.7.9.1	SYNC OPTIONS .....	123
3.7.9.2	CHECK SYNC .....	126
3.7.9.3	AMSC LINK .....	128
3.7.9.4	LOAD CONTROL .....	130
3.7.9.4.1	LOAD CONTROL (MULTI SET) .....	131
3.7.9.4.2	LOAD CONTROL (SINGLE SET) .....	136
3.7.9.4.3	LOAD DEMAND (MULTI SET) .....	138
3.7.9.4.4	CREATING / EDITING THE DROOP CURVES .....	142
3.7.9.5	SET DRIVE PROTECTION .....	144
3.7.9.6	POWER CONTROL .....	147
3.7.9.6.1	CREATING / EDITING THE POWER MODE CURVE .....	150
3.7.9.7	VDE POWER CONTROL .....	151
3.7.9.8	VOLTAGE AND REACTIVE POWER CONTROL .....	153
3.7.9.9	VDE VOLTAGE AND REACTIVE POWER CONTROL .....	158
3.7.9.9.1	CREATING/ EDITING THE VDE VOLTAGE AND REACTIVE POWER CURVE 162	
3.7.9.9.2	VDE VOLTAGE REACTIVE POWER CURVE .....	162
3.7.9.9.3	VDE POWER REACTIVE POWER CURVE .....	166
3.7.9.9.4	VDE REACTIVE POWER LIMITED CURVE .....	167
3.7.10	G99 FAULT RIDE THROUGH .....	168
3.7.11	VDE AND IEEE FAULT RIDE THROUGH .....	171
<b>3.8</b>	<b>BUS (MULTI SET) .....</b>	<b>173</b>
3.8.1	BUS OPTIONS .....	174
3.8.2	BUS SEQUENCE ALARMS .....	175
<b>3.9</b>	<b>MAINS (SINGLE SET ONLY) .....</b>	<b>179</b>
3.9.1	MAINS OPTIONS .....	180
3.9.2	MAINS VOLTAGE ALARMS .....	183
3.9.3	MAINS SEQUENCE ALARMS .....	184
3.9.4	MAINS FREQUENCY ALARMS .....	186
3.9.5	MAINS CURRENT .....	187
<b>3.10</b>	<b>MAINS DECOUPLING .....</b>	<b>188</b>
3.10.1.1	MONITORING .....	189
3.10.1.2	VOLTAGE .....	192
3.10.1.3	FREQUENCY .....	194
3.10.1.4	MISCELLANEOUS OPTIONS .....	196
<b>3.11</b>	<b>ENGINE .....</b>	<b>198</b>
3.11.1	ENGINE PROTECTION .....	199
3.11.2	OIL PRESSURE .....	200
3.11.2.1	EDITING THE OIL SENSOR CURVE .....	201
3.11.3	COOLANT TEMPERATURE .....	204
3.11.3.1	COOLANT TEMPERATURE ALARM .....	204
3.11.3.2	EDITING THE COOLANT SENSOR CURVE .....	205
3.11.3.3	COOLANT TEMPERATURE CONTROL .....	208
3.11.4	FUEL LEVEL .....	209
3.11.4.1	FUEL CONTROL AND MONITORING .....	210
3.11.4.2	CREATING/EDITING FUEL CONTROL & MONITORING SENSOR .....	211
3.11.4.3	FUEL ALARMS .....	217
3.11.5	FUEL USE AND EFFICIENCY .....	220
3.11.6	DEF LEVEL .....	222
3.11.7	ENGINE OPTIONS .....	223
3.11.8	ECU (ECM) OPTIONS .....	225

3.11.9	ECU (ECM) ALARMS.....	228
3.11.9.1	ECU (ECM) DATA FAIL .....	228
3.11.9.2	DM1 SIGNALS .....	229
3.11.9.3	ADVANCED .....	233
3.11.10	GAS ENGINE OPTIONS .....	236
3.11.11	CRANKING .....	237
3.11.12	IDLE SETTING .....	239
3.11.13	SPEED SENSING .....	240
3.11.14	SPEED SETTINGS.....	241
3.11.15	PLANT BATTERY.....	244
3.11.16	INLET TEMPERATURE .....	245
3.11.17	ENGINE ICON DISPLAYS .....	246
3.11.17.1	ICON INSTRUMENTATION .....	247
<b>3.12</b>	<b>COMMUNICATIONS .....</b>	<b>250</b>
3.12.1	COMMUNICATIONS OPTIONS.....	250
3.12.2	RS485 PORTS .....	251
3.12.3	ETHERNET .....	253
3.12.3.1	FIREWALL CONFIGURATION FOR INTERNET ACCESS .....	255
3.12.3.2	INCOMING TRAFFIC (VIRTUAL SERVER).....	255
3.12.4	NOTIFICATIONS.....	256
3.12.4.1	SNMP.....	256
3.12.4.2	NOTIFICATIONS .....	257
<b>3.13</b>	<b>SCHEDULER.....</b>	<b>259</b>
3.13.1	SCHEDULER OPTIONS .....	259
3.13.2	BANK 1 / BANK 2.....	260
<b>3.14</b>	<b>MAINTENANCE ALARM .....</b>	<b>261</b>
<b>3.15</b>	<b>CONFIGURABLE CAN INSTRUMENTATION .....</b>	<b>262</b>
3.15.1	RECEIVED INSTRUMENTATION (1-30).....	263
3.15.1.1	DETAILS .....	264
3.15.2	TRANSMITTED INSTRUMENTATION .....	266
3.15.2.1	DETAILS .....	266
3.15.3	EXPORT / IMPORT CONFIGURABLE CAN .....	268
<b>3.16</b>	<b>ALTERNATIVE CONFIGURATIONS .....</b>	<b>269</b>
3.16.1	ALTERNATIVE CONFIGURATION OPTIONS .....	269
3.16.2	ALTERNATIVE CONFIGURATION 1 TO 5 .....	270
3.16.2.1	CONFIGURATION OPTIONS.....	270
3.16.2.2	GENERATOR / ENGINE /BUS / MAINS / ENGINE.....	270
<b>3.17</b>	<b>EXPANSION .....</b>	<b>271</b>
3.17.1	DSE2130 INPUT MODULES .....	272
3.17.1.1	ANALOGUE INPUT CONFIGURATION .....	273
3.17.1.2	ANALOGUE INPUTS .....	273
3.17.1.3	DIGITAL INPUTS .....	276
3.17.1.3.1	DIGITAL INPUTS .....	277
3.17.1.3.2	ANALOGUE INPUTS .....	278
3.17.2	DSE2131 INPUT MODULES .....	279
3.17.2.1	ANALOGUE INPUT CONFIGURATION .....	280
3.17.2.2	ANALOGUE INPUTS .....	281
3.17.2.3	DIGITAL INPUTS .....	284
3.17.3	DSE2133 INPUT MODULES .....	286
3.17.3.1	ANALOGUE INPUTS .....	287
3.17.4	DSE2152 OUTPUT MODULES .....	290
3.17.4.1	ANALOGUE OUTPUTS.....	291
3.17.4.2	CREATING / EDITING THE OUTPUT CURVE .....	292
3.17.5	DSE2157 RELAY MODULES .....	294
3.17.6	DSE2548 ANNUNCIATOR MODULES.....	295
3.17.7	DSE2160 INPUT MODULE.....	298
3.17.7.1	I/O CONFIGURATION .....	299
3.17.7.2	HIGH FREQUENCY INPUT .....	300
3.17.7.3	DIGITAL INPUTS .....	303
3.17.7.4	ANALOGUE INPUTS .....	305

3.17.7.5	DIGITAL INPUTS/OUTPUTS .....	307
3.17.8	DSE2170 INPUT MODULE .....	308
3.17.8.1	INPUTS A TO D .....	309
3.17.8.2	OUTPUTS A TO D .....	312
3.17.8.3	CREATING / EDITING THE OUTPUT CURVE .....	313
3.17.9	BATTERY CHARGERS .....	315
3.17.10	CREATING / EDITING THE SENSOR CURVES .....	317
<b>3.18</b>	<b>ADVANCED</b> .....	<b>320</b>
3.18.1	ADVANCED OPTIONS .....	321
3.18.2	AVR .....	326
3.18.3	RESET ELECTRICAL TRIP .....	329
3.18.4	PLC .....	330
3.18.5	CONFIGURABLE GENCOMM PAGES 166 TO 169 .....	331
<b>4</b>	<b>SCADA</b> .....	<b>333</b>
<b>4.1</b>	<b>GENERATOR IDENTITY</b> .....	<b>334</b>
<b>4.2</b>	<b>MIMIC</b> .....	<b>334</b>
<b>4.3</b>	<b>DIGITAL INPUTS</b> .....	<b>336</b>
<b>4.4</b>	<b>VIRTUAL INPUTS</b> .....	<b>337</b>
<b>4.5</b>	<b>DIGITAL OUTPUTS</b> .....	<b>338</b>
<b>4.6</b>	<b>VIRTUAL LEDES</b> .....	<b>339</b>
<b>4.7</b>	<b>BUS (MULTI SET)</b> .....	<b>340</b>
<b>4.8</b>	<b>MAINS (SINGLE SET)</b> .....	<b>341</b>
4.8.1	FREQUENCY & VOLTAGES .....	341
4.8.2	POWER .....	342
<b>4.9</b>	<b>GENERATOR</b> .....	<b>343</b>
4.9.1	FREQUENCY, VOLTAGES AND CURRENT .....	344
4.9.2	POWER .....	345
4.9.3	AMSC LINK (MULTI SET) .....	346
4.9.3.1.1	ADJUSTING GAIN (P), STABILITY (I) AND DERIVATIVE (D) .....	347
4.9.4	GOVERNOR / AVR INTERFACE .....	349
4.9.4.1	SW1 .....	349
4.9.4.2	SW2 .....	349
4.9.4.3	VOLTAGE SETTINGS .....	350
4.9.4.4	SUMMARY .....	351
4.9.4.5	CURRENT SETTINGS .....	352
4.9.5	SYNC .....	353
4.9.5.1	ANALOGUE .....	353
4.9.6	LOAD CONTROL (SINGLE SET) .....	356
4.9.7	LOAD LEVELS .....	357
4.9.7.1	MULTI SET MODE .....	358
4.9.7.2	SINGLE SET MODE .....	361
4.9.8	DROOP (MULTI SET) .....	364
4.9.9	DE-RATE .....	365
<b>4.10</b>	<b>ENGINE</b> .....	<b>366</b>
4.10.1	FUEL USE AND EFFICIENCY .....	366
<b>4.11</b>	<b>FLEXIBLE SENSORS</b> .....	<b>367</b>
<b>4.12</b>	<b>CONFIGURABLE CAN INSTRUMENTATION</b> .....	<b>368</b>
<b>4.13</b>	<b>ALARMS</b> .....	<b>369</b>
<b>4.14</b>	<b>ENGINE ALARMS</b> .....	<b>370</b>
4.14.1	CURRENT ENGINE ALARMS .....	370
4.14.2	PREVIOUS ENGINE ALARMS .....	371
<b>4.15</b>	<b>STATUS</b> .....	<b>372</b>
<b>4.16</b>	<b>EVENT LOG</b> .....	<b>373</b>
<b>4.17</b>	<b>ENHANCED CANBUS</b> .....	<b>374</b>
<b>4.18</b>	<b>MAINTENANCE</b> .....	<b>374</b>
4.18.1	RECALIBRATE TRANSDUCERS (A TO G) .....	375
4.18.2	EXPANSION CALIBRATION .....	376
4.18.3	HOURS RUN AND NUMBER OF STARTS .....	376
4.18.4	TIME .....	377

4.18.5	ACCUMULATED INSTRUMENTATION .....	378
4.18.6	FULE USE AND EFFICIENCY .....	379
4.18.7	MAINTENANCE ALARM RESET .....	380
4.18.8	ELECTRONIC ENGINE CONTROLS .....	381
4.18.9	MODULE PIN .....	382
<b>4.19</b>	<b>COMMUNICATIONS INFORMATION.....</b>	<b>383</b>
<b>4.20</b>	<b>DATA LOG .....</b>	<b>384</b>
4.20.1	DATA LOG STATUS .....	385
<b>4.21</b>	<b>AVR.....</b>	<b>386</b>
4.21.1	FREQUENCY, VOLTAGES AND CURRENT .....	386
4.21.2	DIAGNOSTICS .....	387
4.21.3	STATUS .....	387
4.21.4	CONTROL .....	388
4.21.5	AVR ALARMS .....	388
<b>4.22</b>	<b>EXPANSION .....</b>	<b>389</b>
<b>5</b>	<b>ALARM TYPES.....</b>	<b>390</b>
<b>6</b>	<b>ALARM ARMING.....</b>	<b>391</b>
6.1	NEVER .....	392
6.2	ALWAYS .....	392
6.3	WHEN STATIONARY .....	392
6.4	FROM STARTING .....	392
6.5	OVERSHOOT .....	392
6.6	FROM SAFETY ON.....	393
6.7	FROM BREAKER CLOSED .....	393
6.8	FROM MAINS PARALLEL .....	393

## 1 INTRODUCTION

This document details the use of the *DSE Configuration Suite PC Software* with the DSEG8600 module, which is part of the DSE **GenSet**® range of products.

The manual forms part of the product and must be kept for the entire life of the product. If the product is passed or supplied to another party, ensure that this document is passed to them for reference purposes.

This is not a *controlled document*. DSE do not automatically inform on updates. Any future updates of this document are included on the DSE website at [www.deepseaelectronics.com](http://www.deepseaelectronics.com)



The *DSE Configuration Suite PC Software* allows the DSEG8600 module to be connected to a PC via USB A to USB B cable (USB printer cable). Once connected, the software allows easy, controlled access to various operating parameters within the module, which are then viewed and edited as required.

The *DSE Configuration Suite PC Software* must only be used by competent, qualified personnel, as changes to the operation of the module may have safety implications on the panel / generating set to which it is fitted. Access to critical operational sequences and settings for use by qualified engineers, may be barred by a security code set by the generator provider.

The information contained in this manual must be read in conjunction with the information contained in the appropriate module documentation. This manual only details which settings are available and how they may be used. Separate manuals deal with the operation of the individual module and its ancillaries, refer to the section entitled *Bibliography* elsewhere in this document.

## 1.1 CLARIFICATION OF NOTATION

Clarification of notation used within this publication.

	<b>NOTE:</b>	Highlights an essential element of a procedure to ensure correctness.
	<b>CAUTION!</b>	Indicates a procedure or practice, which, if not strictly observed, results in damage or destruction of equipment.
	<b>WARNING!</b>	Indicates a procedure or practice, which results in injury to personnel or loss of life if not followed correctly.

## 1.2 GLOSSARY OF TERMS

Term	Description
AC	Alternating Current
AMSC	Advanced Multi-Set Communication
AVR	Automatic Voltage Regulator
BMS	Building Management System A computer-based control system for a building's infrastructure.
BUS	BUS is a communication system that transfers data between components inside a computer, or between computers.
CAN	Controller Area Network Vehicle standard to allow digital devices to communicate to one another.
CDMA	Code Division Multiple Access. Cell phone access used in small number of areas including parts of the USA and Australia.
CT	Current Transformer An electrical device that takes a large AC current and scales it down by a fixed ratio to a smaller current.
DC	Direct Current
DEF	Diesel Exhaust Fluid (AdBlue) A liquid used as a consumable in the SCR process to lower nitric oxide and nitrogen dioxide concentration in engine exhaust emissions.
DHCP	DHCP (Dynamic Host Configuration Protocol) is a protocol that provides quick, automatic, and central management for the distribution of IP addresses within a network.
DM1	Diagnostic Message 1 A diagnostic message that contains one or more DTCs that are currently active on the engine ECU.
DM2	Diagnostic Message 2 A DTC that was previously active on the engine ECU and has been stored in the ECU's internal memory.
DNS	Domain Name Server
DPF	Diesel Particulate Filter A filter fitted to the exhaust of an engine to remove diesel particulate matter or soot from the exhaust gas.
DPTC	Diesel Particulate Temperature Controlled Filter A filter fitted to the exhaust of an engine to remove diesel particulate matter or soot from the exhaust gas which is temperature controlled.
DTC	Diagnostic Trouble Code The name for the entire fault code sent by an engine ECU.
ECU/ECM	Engine Control Unit/Management An electronic device that monitors engine parameters and regulates the fuelling.

Continued over page...

Introduction

Term	Description
EMC	Electromagnetic compatibility is the ability of electrical equipment and systems to function in their electromagnetic environment
FMI	Failure Mode Indicator. A part of DTC that indicates the type of failure, e.g., high, low, open circuit etc.
FPE	Front Panel Editor
FRT	Fault Ride Through
Fuel Tank Bund	An external tank used to collect fuel that may leak or overflow from the fuel tank. This tank may also be integral to the main fuel tank. A level switch is usually located within the Bund to indicate the presence of the leak or overflow condition.
GB	Gigabyte
GPRS	General Packet Radio Service
GSM	Global System for Mobile communications. Cell phone technology used in most of the World.
HEST	High Exhaust System Temperature Initiates when DPF filter is full in conjunction with an extra fuel injector in the exhaust system to burn off accumulated diesel particulate matter or soot.
IDMT	Inverse Definite Minimum Time
IEEE	Institute of Electrical and Electronics Engineers
ISBN	International Standard Book Number
LAN	Local Area Network
LCD	Liquid Crystal Display
LED	Light Emitting Diode
LSB	Least Significant Bit
MPU	Magnetic Pickup
MSB	Most Significant Bit
NAPT	Network Address and Port Translation
NVD	Neutral Voltage Displacement
OEM	Original Equipment Manufacturer
P	Active power, measured in watts (W).
P/Pbinst	This represents the normalized active power. It is the ratio of the actual active power P to the base power installation P/Pbinst.
PCI	Peripheral Component Interface
PCMCIA	Personal Computer Memory Card International Association
PDU	Protocol Data Unit.
PGN	Parameter Group Number. A CANbus address for a set of parameters that relate to the same topic and share the same transmission rate.
PID	<i>Gain (P)</i> , <i>Stability (I)</i> and <i>Derivative (D)</i> settings of the engine's governor
PIN	Personal Identification Number
PLC	Programmable Logic Controller. A programmable digital device used to create logic for a specific purpose.
Q	Reactive power measured in volt-amperes reactive (VAR).
Q/Pbinst	The ratio of reactive power to the generated power, e.g. 0.33 equals a power factor of 0.95.
QMax	QMax refers to the maximum overexcited reactive power that a generator can supply. It typically corresponds to the upper limit of reactive power output at a specific voltage point (e.g., P1) on the Reactive Power Limited Curve. This value is critical for ensuring grid stability and compliance with reactive power requirements.
QP/Pb	QP/Pb represents the maximum under-excited reactive power on a Reactive Power Limited Curve. It defines the lowest reactive power output the generator can supply at a specific voltage point (typically P4), ensuring compliance with grid requirements for reactive power absorption.
QU	QU represents the reactive power between curve points on a Reactive Power Limited Curve. It defines the generator's reactive power output under normal grid voltage conditions and is influenced by the Displ parameter, which is remotely set by the grid operator to adjust the operating power factor.

Continued over page...

*Introduction*

<b>Term</b>	<b>Description</b>
R.O.C.O.F.	Rate Of Change Of Frequency
RMS	Root Mean Square
RPM	Revolutions Per Minute
RTD	Resistance Thermometer Detectors
SCADA	Supervisory Control And Data Acquisition A system that operates with coded signals over communication channels to provide control and monitoring of remote equipment
SCR	A process that uses DEF with the aid of a catalyst to convert nitric oxide and nitrogen dioxide into nitrogen and water to reduce engine exhaust emission.
SNMP	Simple Network Management Protocol. An international standard protocol for managing devices on IP networks.
SPN	Suspect Parameter Number. A part of DTC that indicates what the failure is, e.g., oil pressure, coolant temperature, turbo pressure etc.
TCP	TCP (Transmission Control Protocol) is a standard that defines how to establish and maintain a network conversation via which application programs can exchange data.
U	U denotes voltage in European and German electrical engineering standards, including VDE. It typically represents the electrical potential difference between two points in a circuit and is measured in volts (V).
UC	UC represents voltage in the context of a Reactive Power Limited Curve. It is used to define the voltage level at specific curve points (e.g., P1, P2, P3, P4) and is functionally equivalent to UP in this setting. The notation may vary depending on the system or software interface but serves the same purpose: identifying the voltage at which reactive power behaviour is evaluated.
UL	Underwriters Laboratory
UP	UP refers to the voltage value assigned to specific points (P1, P2, P3, P4) on a Reactive Power Limited Curve. These values define the voltage levels at which the generator's reactive power response is evaluated and controlled.
USB	Universal Serial Bus
VDE	Verband der Elektrotechnik VDE is the German Association for Electrical, Electronic & Information Technologies. It sets technical standards, certifies electrical products, and promotes safety and innovation in electrical engineering.
WAN	Wide Area Network

## 1.3 BIBLIOGRAPHY

This document refers to and is referred by the following DSE publications which are obtained from the DSE website: [www.deepseaelectronics.com](http://www.deepseaelectronics.com) or by contacting DSE technical support: [support@deepseaelectronics.com](mailto:support@deepseaelectronics.com).

### 1.3.1 INSTALLATION INSTRUCTIONS

Installation instructions are obtained from the DSE website: [www.deepseaelectronics.com](http://www.deepseaelectronics.com) or by contacting DSE technical support: [support@deepseaelectronic.com](mailto:support@deepseaelectronic.com) and are intended as a 'quick start' guide only.

DSE Part	Description
053-032	DSE2548 LED Expansion Annunciator Installation Instructions
053-033	DSE2130 Input Expansion Installation Instructions
053-034	DSE2157 Output Expansion Installation Instructions
053-049	DSE9xxx Battery Charger Installation Instructions
053-125	DSE2131 Ratio-metric Input Expansion Installation Instructions
053-126	DSE2133 RTD/Thermocouple Input Expansion Installation Instructions
053-134	DSE2152 Ratio-metric Output Expansion Installation Instructions
053-147	DSE9460 & DSE9461 Battery Charger Installation Instructions
053-152	DSE123 Cummins PCC Variant Installation Instructions
053-185	DSE9473 & DSE9483 Battery Charger Installation Instructions
053-233	DSEA108 Installation Instructions
053-245	DSEA109 Installation Instructions
053-253	DSEG8660 Installation Instructions
053-254	DSEG8680 Installation Instructions
053-256	DSEG8600 Installation Instructions
053-263	DSEG0123 Installation Instructions Installation Instructions
053-268	DSE2160 Input/Output Expansion Module Installation Instructions
053-269	DSE2170 RTD/Thermocouple Input/Output Expansion Module Installation Instructions

### 1.3.2 MANUALS

Product manuals are obtained from the DSE website: [www.deepseaelectronics.com](http://www.deepseaelectronics.com) or by contacting DSE technical support: [support@deepseaelectronics.com](mailto:support@deepseaelectronics.com).

DSE Part	Description
057-004	Electronic Engines and DSE Wiring Guide
057-045	Guide to Synchronising and Load Sharing Part 1 (Usage of DSE Load Share Controllers in synchronisation / load sharing systems.)
057-046	Guide to Synchronising and Load Sharing Part 2 (Governor & AVR Interfacing)
057-047	Load Share System Design and Commissioning Guide
057-082	DSE2130 Input Expansion Operator Manual
057-083	DSE2157 Output Expansion Operator Manual
057-084	DSE2548 Annunciator Expansion Operator Manual
057-085	DSE9xxx Battery Charger Operator Manual
057-139	DSE2131 Ratio-metric Input Expansion Manual
057-140	DSE2133 RTD/Thermocouple Expansion Manual
057-141	DSE2152 Ratio-metric Output Expansion Manual
057-151	DSE Configuration Suite PC Software Installation & Operation Manual
057-176	DSE9460 & DSE9461 Battery Charger Operator Manual
057-312	DSEAssistant PC Software Manual
057-314	Advanced PLC Software Manual
057-323	DSEG8600 Operator Manual
057-350	DSEG0123 Operator Manual
057-361	DSE2160 Input & Output Expansion Module Operator Manual
057-362	DSE2170 RTD/Thermocouple Input & Analogue Output Expansion Module Operator Manual
N/A	DSEGenComm (Modbus protocol for DSE controllers)

### 1.3.3 TRAINING GUIDES

Training guides are provided as 'hand-out' sheets on specific subjects during training sessions and contain specific information regarding to that subject.

<b>DSE Part</b>	<b>Description</b>
056-001	Four Steps To Synchronising
056-005	Using CTs With DSE Products
056-006	Introduction to Comms
056-010	Over Current Protection
056-013	Load Demand Scheme
056-018	Negative Phase Sequence
056-019	Earth Fault Protection
056-020	Loss Of Excitation
056-021	Mains Decoupling
056-022	Switchgear Control
056-023	Adding New CAN Files
056-024	GSM Modem
056-026	kVA, kW, kvar and Power Factor
056-028	Smoke Limiting
056-030	Module PIN Codes
056-033	Synchronising Requirements
056-036	DSE Module Expansion
056-043	Sync Process
056-045	PLC as Load Demand Controller
056-047	Out of Sync and Failed To Close
056-051	Modbus Control
056-053	Recommended Modems
056-055	Alternate Configurations
056-057	SW1 & SW2
056-069	Firmware Update
056-072	Dead Bus Synchronising
056-075	Adding Language Files
056-076	GenComm Alarms
056-079	GenComm Status
056-080	Modbus
056-081	Screen Heaters
056-082	Override GenComm PLC Example
056-084	Synchronising & Load sharing
056-086	G59
056-091	Equipotential Earth Bonding
056-092	Best Practices for Wiring Restive Sensors
056-095	Multi Set Controller Input Functions
056-097	USB Earth Loops and Isolation
056-099	Digital Output to Digital Input Connection
056-118	Configurable CAN
056-123	Simulation Injection Testing

### 1.3.4 THIRD PARTY DOCUMENTS

The following third-party documents are also referred to:

Reference	Description
ISBN 1-55937-879-4	IEEE Std C37.2-1996 IEEE Standard Electrical Power System Device Function Numbers and Contact Designations. Institute of Electrical and Electronics Engineers Inc
ISBN 0-7506-1147-2	Diesel generator handbook. L.L.J. Mahon
ISBN 0-9625949-3-8	On-Site Power Generation. EGSA Education Committee.

## 1.4 INSTALLATION AND USING THE DSE CONFIGURATION SUITE SOFTWARE

For information regarding installing and using the *DSE Configuration Suite PC Software*, refer to DSE publication: **057-151 DSE Configuration Suite PC Software Installation & Operation Manual** which is found on the DSE website: [www.deepseaelectronics.com](http://www.deepseaelectronics.com)

## 2 GENERAL CONTROLS

**NOTE:** For information on Menu & Toolbars please refer to DSE Publication: 057-151 *DSE Configuration Suite PC Software Installation & Operation Manual*

### Overview

The *DSE Configuration Suite PC Software* dialog boxes provide the user with a way to type text, choose options, and initiate actions. Controls in other windows provide a variety of services, such as letting the user choose commands and view and edit text. This section describes the controls provided by the *DSE Configuration Suite* and how to manipulate them. The diagram below shows the general controls of the main configuration screen.

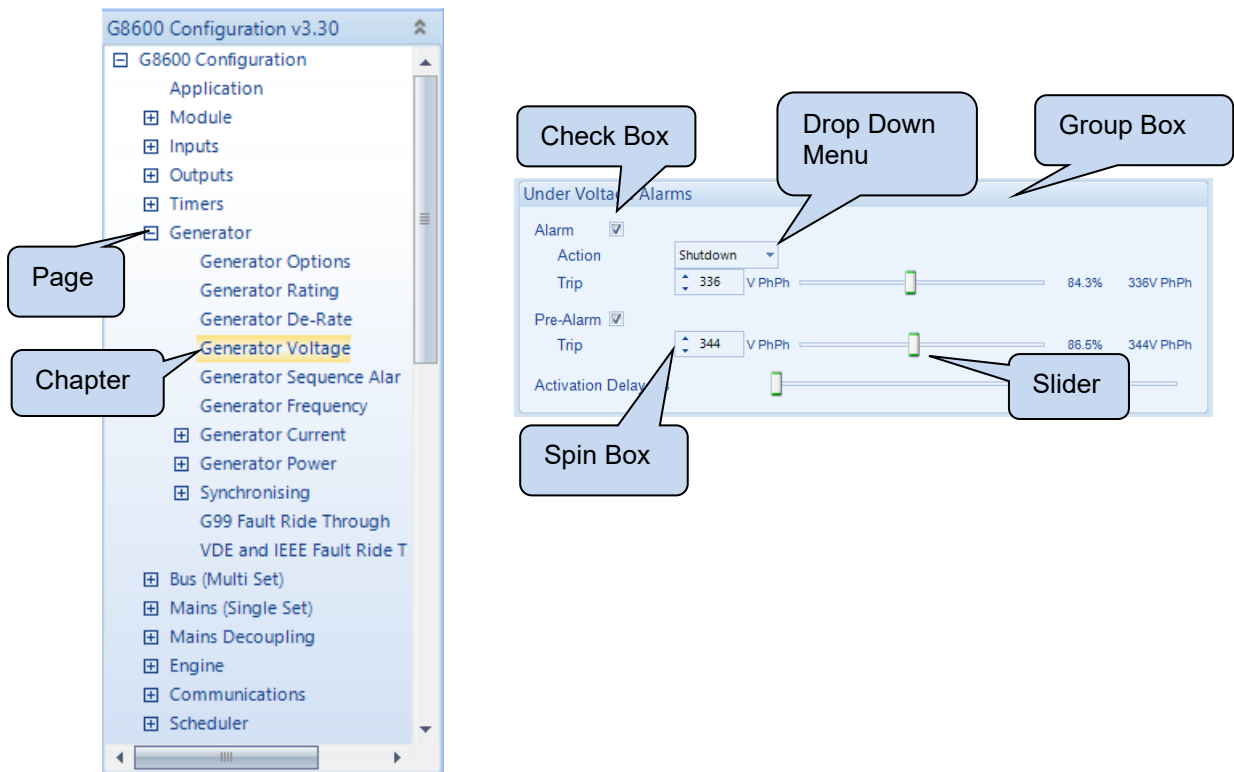

### 2.1 USER CONTROLS

#### Slider

The Slider Control allows the user to change a value using a mouse or arrows found on a standard keyboard.

The slider is highlighted in green in its inactive state and changes to orange (active state) once selected by a mouse pointer.

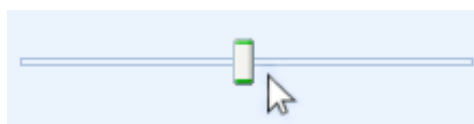

Inactive state

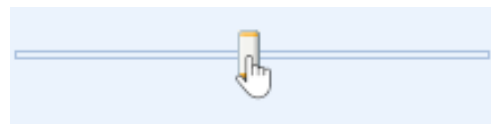

Active state

During the active state, the slider is moved with the mouse pointer and the left and right keyboard arrows.

### **Spin Box**

The Spin box displays the current value of the setting in the group box.

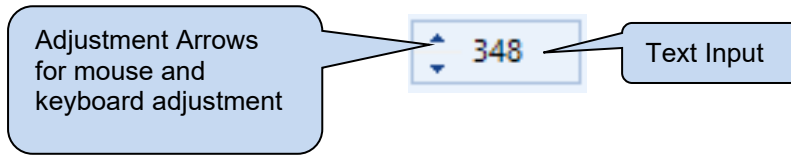

Clicking the mouse over the Spin box changes its colour to orange, putting it in an active state.



During the active state text is entered using the keyboard, changed using the mouse pointer or the up and down arrows on the keyboard.

### **Check box**



Used to select a parameter

### **Drop down menu**

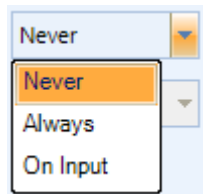

Used to select an action

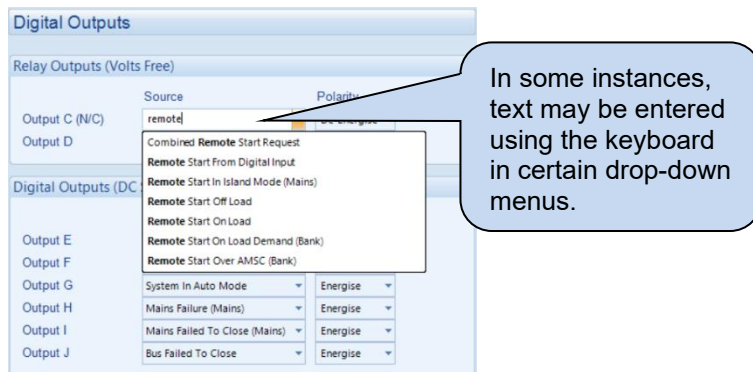

Used to select a source

### 3 EDITING THE CONFIGURATION

The software is broken down into separate sections to provide simple navigation whilst editing the module's configuration to suit a particular application.

#### 3.1 SCREEN LAYOUT

The type of module configuration file being edited

Click to move to the *Previous* or *Next* section

Click to close the opened configuration file

The coloured shading shows the currently selected page or section within a page

Click + or – to expand or collapse the section

The screenshot shows a software interface for 'G8600 Configuration v3.32'. At the top, there are 'Previous' and 'Next' buttons. Below them is a tree view of configuration sections: Application (highlighted in yellow), Module, Inputs, Outputs, Timers, Generator, Bus (Multi Set), Mains (Single Set), Mains Decoupling, Engine, Communications, Scheduler, Maintenance Alarm, Configurable CAN Instrumentation, Alternative Configurations, Expansion, and Advanced. Each section has a small square icon to its left, which can be expanded or collapsed.

Click to step *Forward* or *Back* through previously viewed configuration sections

Click to return to the *Home* section shown below

Click to view and edit the section

The screenshot shows the 'G8600 Configuration' software interface. At the top, there are 'Back' and 'Forward' buttons. Below them is a list of configuration sections: Application, Module, Inputs, Outputs, Timers, Generator, Bus, Mains, Mains Decoupling, Engine, Communications, Scheduler, Maintenance Alarm, Configurable CAN Instrumentation, Alternative Configurations, and Expansion. Each section is a blue hyperlink. To the right of the list is a photograph of the physical G8600 device, which is a black rectangular unit with a green screen displaying 'DSE' and several buttons and a dial.

### 3.2 APPLICATION

#### Application Switching

The *Application Switching* page allows the user to configure the module as a *Multiset Controller*, *Single Set Controller* or set dynamically to switch between each application.

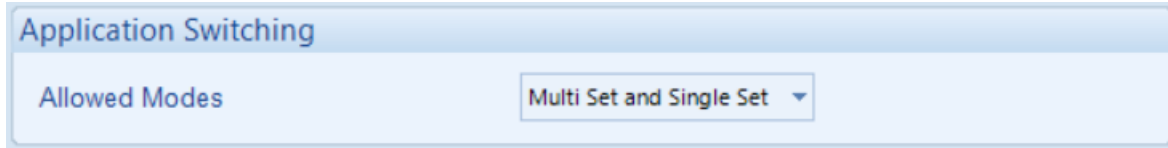

Parameter	Description
Allowed Modes	<p>Select the operating application of module:</p> <p><b>Single Set Only:</b> Enables only the Single Set Controller application. This enables the module to start and stop the generator, and if required, synchronise and load-share the generator with the mains to provide Single Set Control with mains fail detection and peak lopping/shaving functionality.</p> <p><b>Multi Set and Single Set:</b> Enables both the Multi Set Controller and Single Set Controller application. The application is dynamically selected by activation of a <i>Digital Input</i>, <i>GenComm page 16 command</i> or the <i>Front Panel Editor</i>.</p> <p><b>Multi Set Only:</b> Enables only the Multi Set Controller application. This enables the module to start and stop the generator, and if required, synchronise and load-share the generator with other generators in the system.</p>

**⚠ CAUTION!:** In Single Set Mode, the controller operates independently and does not interact with other sets over AMSC.

**ECU (ECM Options)**

**NOTE:** For further details and instructions on ECU (ECM) options and connections, refer to DSE Publication: *057-004 Electronic Engines and DSE Controllers* which are found on our website: [www.deepseaelectronics.com](http://www.deepseaelectronics.com)

Parameter	Description
Engine Type	<p>Select the appropriate engine type...</p> <p><b>Conventional Diesel:</b> Select this for a traditional (non-electronic) engine, either Energise to Run or Energise to Stop.</p> <p><b>Conventional Gas Engine:</b> Select this for a traditional (non-electronic) engine and require Gas engine functionality. This enables control of configurable outputs for <i>Gas Choke and Gas Ignition</i> and instructs the module to follow the gas engine timers.</p> <p><b>ECU/ECM Engines:</b> The list of supported engine ECUs is constantly updated. To ensure the DSE Configuration Suite is up to date to attain the latest releases, navigate to <i>Help</i> menu and <i>Check For Updates</i>.</p>
Enhanced J1939	<p><input type="checkbox"/> = The module reads 'Basic' instrumentation from the engine ECU (ECM) and display (where supported by the engine):</p> <p><input checked="" type="checkbox"/> = The module reads and display an 'Enhanced' instrumentation list (where supported by the engine):</p> <p>Where an instrument is not supported by the engine ECU (ECM), the instrument is not displayed. DSE Reserve the right to change these lists in keeping with our policy of continual development.</p>
Alternative Engine Speed	<p><input type="checkbox"/> = The engine is instructed to run at its <i>Nominal Speed</i> as configured by the Engine Manufacturer.</p> <p><input checked="" type="checkbox"/> = The engine is instructed to run at its <i>Alternative Speed</i> as configured by the Engine Manufacturer.</p>
Modbus Engine Comms Port	<p><b>RS485 Port 1:</b> The modules RS485 port is used to communicate to the engine (when a Modbus engine type is selected).</p> <p><b>DSENet Port:</b> The modules DSENet port is used to communicate to the engine (when a Modbus engine type is selected. This 'frees' the RS485 port in case connection to BMS or other RS485 compatible equipment is required.</p>

Parameter descriptions are continued overleaf...

**Auto Voltage Sensing (Multi Set)**

**Auto Voltage Sensing (Multi Set)**

Enable Auto Voltage Sensing

Over Voltage During Auto Sensing Trip  V PhN 

Option	Description
Enable Auto Voltage Sensing	<p><input type="checkbox"/> = The module uses the selected <i>Main Configuration</i> or <i>Alternative Configuration</i>.</p> <p><input checked="" type="checkbox"/> = <i>Auto Voltage Sensing</i> is enabled. When the generator is started, the module monitors the generator voltage. Depending on the voltage level and <i>AC System</i> detected, the module automatically selects between the <i>Mains Configuration</i> and <i>Alternative Configuration</i>. This is useful for hire generators where the <i>AC System</i> is selectable as no digital input signals are required to be given to the DSE module.</p>

**NOTE: Auto Voltage Sensing is not available in Single Set Mode.**

### 3.3 MODULE

The *Module* section allows the user to edit options related to the module itself and is subdivided into smaller sections.

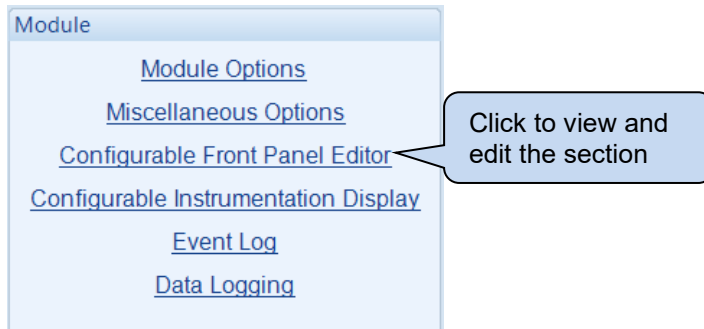

#### 3.3.1 MODULE OPTIONS

##### Description

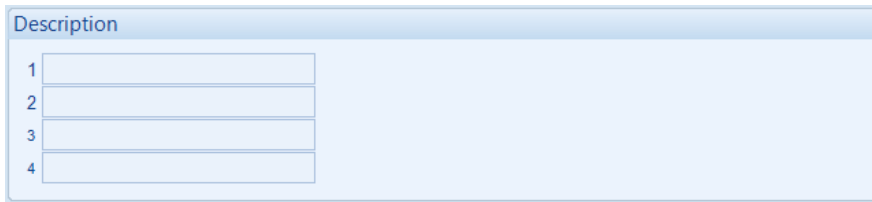

Parameter	Description
Description	<p>Four free entry boxes to allow the user to give the configuration file a description. Typically used to enter the job number, customer name, engine information etc.</p> <p>This text is not shown on the module's display and is only seen in the configuration file.</p>

**Start Up Image**

The module is configured to display a *Start UP* image as soon as it is powered up.

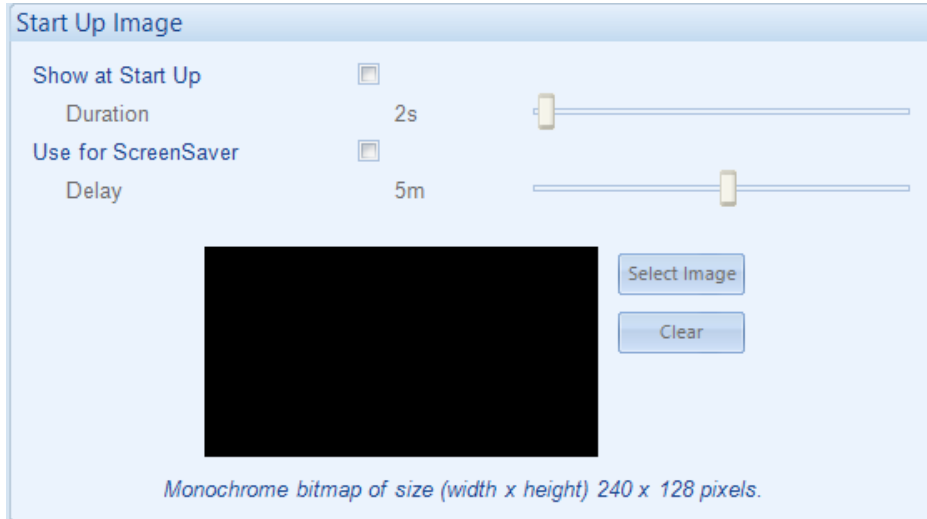

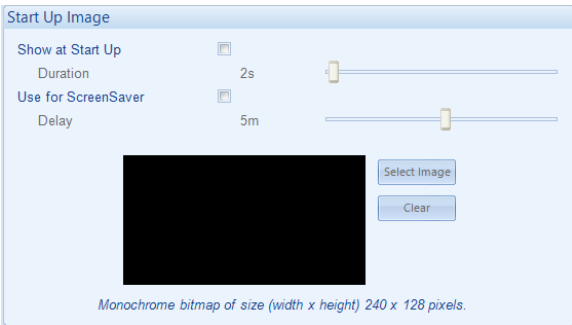
Parameter	Description
Show at Start Up	<input type="checkbox"/> = Start Up screen is disabled <input checked="" type="checkbox"/> = Enable a <i>Start Up Text</i> or <i>Image</i> to be displayed on the module's LCD at power up.  
Use for ScreenSaver	<input type="checkbox"/> = ScreenSaver is disabled <input checked="" type="checkbox"/> = Module activates the ScreenSaver to show the selected image after inactivity in any mode for the configured <i>Delay</i> time. Press any button to 'end' the ScreenSaver.
Select Image	Browse and select the image file to display at power up. The file required must be a monochrome bitmap image of size 240 pixels in width by 128 pixels in height.
Clear	Clears the image file selection.
Duration	Set the duration for which the <i>Start Up Image</i> is displayed at power up.

**Power Saving Options**

The modules backlight is switched off after the timer setting in *Backlight Power Save Mode Delay* in *Module Timers* has expired.

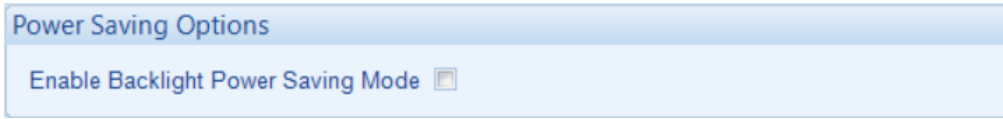

Parameter	Description
Enable Backlight Power Saving Mode	<input type="checkbox"/> = The <i>Backlight Power Saving Mode</i> is disabled. <input checked="" type="checkbox"/> = The <i>Backlight Power Saving Mode</i> is enabled.

**Breaker Control**

This setting allows control over a Manual Breaker.

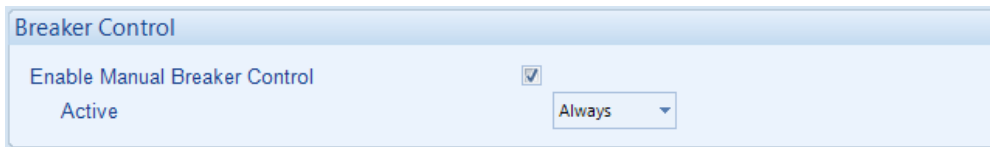



Parameter	Description
Enable Manual Breaker Control	<input type="checkbox"/> = The <i>Manual Breaker Control</i> is disabled. <input checked="" type="checkbox"/> = The <i>Manual Breaker Control</i> is enabled.  The <i>Manual Breaker Control</i> is activated: <b>Always:</b> <i>Manual Breaker Control</i> is always active. The module breaker buttons override load input requests, so the breaker is opened. <b>On Input:</b> <i>Manual Breaker Control</i> is only active when a digital input configured for <i>Manual Breaker Mode</i> is active.





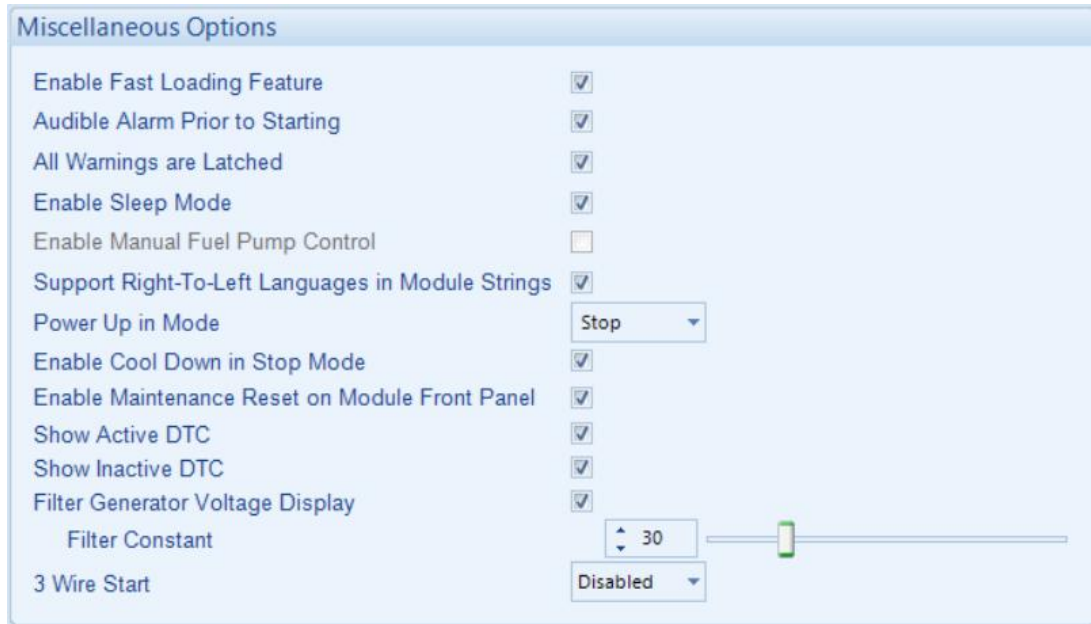





### 3.3.2 MISCELLANEOUS OPTIONS

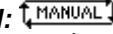

#### Miscellaneous Options

Various Module options are configurable on this page.



Parameter	Description
Enable Fast Loading	<p><b>NOTE:</b> Enabling Fast Loading is only recommended where steps have been taken to ensure rapid start-up of the engine is possible. (For example, when fitted with engine heaters, electronic governors etc.)</p> <p><input type="checkbox"/> = The <i>Fast Loading</i> is disabled. The module observes the <i>Safety on Delay</i> timer in full to allow the generator time to reach operating <i>Oil Pressure, Coolant Temperature, Engine Speed, Loading Voltage and Loading Frequency</i>.</p> <p><input checked="" type="checkbox"/> = The <i>Fast Loading</i> is enabled. The module terminates the <i>Safety on Delay</i> timer once the generator has attained the <i>Loading Voltage and Loading Frequency</i>. This feature is useful if the generator is to be used in critical application as it allows it to start and go on load in the shortest possible time.</p>
Audible Alarm Prior to Starting	<p><input type="checkbox"/> = The <i>Audible Alarm Prior to Starting</i> is disabled.</p> <p><input checked="" type="checkbox"/> = The <i>Audible Alarm Prior to Starting</i> is enabled. The module gives an audible warning during the <i>Pre-Heat Timer</i> to indicate the generator is about to start.</p>
All Warnings Are Latched	<p><input type="checkbox"/> = The <i>All Warnings Are Latched</i> is disabled. The module automatically resets the warning and <i>Pre-Alarms</i> once the triggering condition has been cleared.</p> <p><input checked="" type="checkbox"/> = The <i>All Warnings Are Latched</i> is enabled. The module does not automatically reset the warning and <i>Pre-Alarms</i>. Resetting the alarm is performed by either activating a digital input configured for <i>Alarm Reset, individual alarms using PLC</i>, or pressing the <b>Stop/Reset Mode</b>  button once the triggering condition has been cleared. This option is forced by the load demand scheme (Multi Set) if the <i>Load/start next set on warning</i> option is enabled.</p>

Parameter	Description
Enable Sleep Mode	<p><input type="checkbox"/> = The <i>Sleep Mode</i> is disabled.</p> <p><input checked="" type="checkbox"/> = The <i>Sleep Mode</i> is enabled. The module goes into a low current mode when it is left in the <b>Stop/Reset Mode</b>  for the duration of the <i>Sleep Timer</i> if the communication ports or data logging facility are not active. During the <i>Sleep Mode</i> the module effectively powers down and its display turns off. Press <b>Stop/Reset Mode</b>  button on the module's facia to take it out of <i>Sleep Mode</i>.</p>
Enable Manual Fuel Pump Control	<div style="border: 1px solid black; padding: 5px; margin-bottom: 5px;"> <p><b>! CAUTION! It is possible to overfill the fuel tank when using the Manual Fuel Pump Control feature. Care must be taken to ensure the correct volume of fuel is transferred.</b></p> </div> <div style="border: 1px solid black; padding: 5px; margin-bottom: 5px;"> <p><b>▲ NOTE: Manual Fuel Pump Control is only available when a fuel level sensor is configured.</b></p> </div> <p><input type="checkbox"/> = The <i>Manual Fuel Pump Control</i> is disabled.</p> <p><input checked="" type="checkbox"/> = The <i>Manual Fuel Pump Control</i> is enabled. To manually control the fuel pump, press the <b>Tick</b>  button when viewing the <i>Fuel Level</i> instrument on the module's display.</p>
Support Right-To-Left Languages in Module Strings	<p><input type="checkbox"/> = The <i>Support Right-To-Left Languages in Module Strings</i> is disabled. The module displays user configured strings in the order left to right.</p> <p><input checked="" type="checkbox"/> = The <i>Support Right-To-Left Languages in Module Strings</i> is enabled. The module displays user configured strings in the order right to left.</p>
Power Up in Mode	<p>Select the mode which the module enters once DC power is applied.</p> <p><b>Auto:</b>  The module powers up in the <b>Auto Mode</b>.</p> <p><b>Manual:</b>  The module powers up in the <b>Manual Mode</b>.</p> <p><b>Stop:</b>  The module powers up in the <b>Stop/Reset Mode</b></p> <p><b>Test (Single Set):</b>  The module powers up in <b>Test (Single Set) Mode</b></p>
Enable Cool Down in Stop Mode	<p><input type="checkbox"/> = The <i>Cool Down in Stop Mode</i> is disabled. Pressing the <b>Stop/Reset Mode</b>  button instructs the module to immediately open the generator's switchgear and stop the generator.</p> <p><input checked="" type="checkbox"/> = The <i>Cool Down in Stop Mode</i> is enabled. Pressing the <b>Stop/Reset Mode</b>  button instructs the module to immediately open the generator's switchgear and instructs the generator to run for the duration of the <i>Cooling cycle</i> i.e., cooling down or cooling down and cooling at idle. Pressing the <b>Stop/Reset Mode</b>  button again results in the generator stopping immediately.</p>
Enable Maintenance Reset on Module Front Panel	<p><input type="checkbox"/> = The <i>Maintenance Reset on Module Front Panel</i> is disabled. The maintenance alarms are only reset using a digital input configured for <i>Maintenance Alarm Reset</i> or the SCADA section of the <i>DSE Configuration Suite</i>.</p> <p><input checked="" type="checkbox"/> = The <i>Maintenance Reset on Module Front Panel</i> is enabled. The maintenance alarms are resettable by pressing and holding the <b>Stop/Reset Mode</b>  button when viewing the specific <i>Maintenance</i> instrument on the module's display.</p>

Parameter	Description
Show Active DTC	<p> <b>NOTE:</b> Show Active DTC is only available when the module is configured to communicate to an engine's ECU/ECM over CANbus.</p> <p><input type="checkbox"/> = The <i>Show Active DTC</i> is disabled. The module does not display DM1 fault codes that are active on the engine ECU/ECM.</p> <p><input checked="" type="checkbox"/> = The <i>Show Active DTC</i> is enabled. The module displays DM1 fault codes that are active on the engine ECU/ECM.</p>
Show Inactive DTC	<p> <b>NOTE:</b> Show Inactive DTC is only available when the module is configured to communicate to an engine's ECU/ECM over CANbus.</p> <p><input type="checkbox"/> = The <i>Show Inactive DTC</i> is disabled. The module does not display the historical log of DM2 fault codes from the engine ECU/ECM.</p> <p><input checked="" type="checkbox"/> = The <i>Show Inactive DTC</i> is enabled. The module displays the historical log of DM2 fault codes from the engine ECU/ECM.</p>
Filter Generator Voltage Display	<p> <b>NOTE:</b> The generator voltage is only filtered on the module's display and not on the SCADA or any other remote monitoring device.</p> <p><input type="checkbox"/> = The <i>Filter Generator Voltage Display</i> is disabled. The rate at which the generator voltage instruments are refreshed to display all voltage fluctuations.</p> <p><input checked="" type="checkbox"/> = The <i>Filter Generator Voltage Display</i> is enabled. The rate at which the generator voltage instruments are refreshed is configurable based on the <i>Filter Constant</i>. A larger <i>Filter Constant</i> leads to a slower refresh rate, filtering out the fluctuations on the generator voltage instruments.</p>
3 Wire Start	<p>This is a failsafe function so that if the associated input fails, the set still starts and a warning alarm is raised to indicate a failure on one of the inputs.</p> <p>Select the type of option required from the list:</p> <p><b><i>Disabled</i></b>  <b><i>Remote Start Island Mode</i></b>  <b><i>Remote Start On Load</i></b></p>

**Miscellaneous Options (Multi Set)**

Various Module options for the *Multi Set* application are configurable on this page.

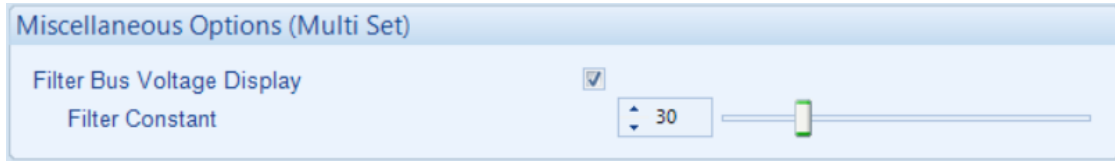

Parameter	Description
Filter Bus Voltage Display	<p><b>NOTE:</b> The Mains voltage is only filtered on the module's display and not on the SCADA or any other remote monitoring device.</p> <p><input type="checkbox"/> = The <i>Filter Bus Voltage Display</i> is disabled. The rate at which the bus voltage instruments are refreshed to display all voltage fluctuations.</p> <p><input checked="" type="checkbox"/> = The <i>Filter Bus Voltage Display</i> is enabled. The rate at which the bus voltage instruments are refreshed is configurable based on the <i>Filter Constant</i>. A larger <i>Filter Constant</i> leads to a slower refresh rate, filtering out the fluctuations on the bus voltage instruments.</p>

**Miscellaneous Options (Single Set)**

Various Module options for the *Single Set* application are configurable on this page.

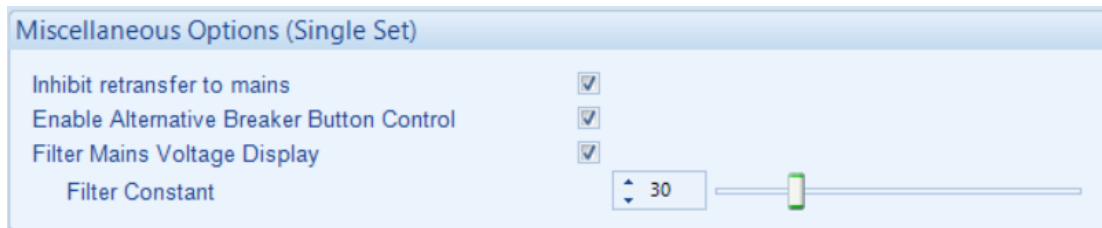

Parameter	Description
Inhibit retransfer to mains <i>IEEE C37.2 - 3 Checking or Interlocking Relay</i>	<p><input type="checkbox"/> = When the mains supply is reinstated after a failure, the re-transfer back to mains takes place.</p> <p><input checked="" type="checkbox"/> = This prevents the load being transferred back to the mains supply, ONLY in the event of the generator failure. This is used in peak lopping systems where the cost of using the mains to supply the load is so prohibitive that the customer does not want to transfer back to the mains supply.</p>
Enable Alternative Breaker Button Control	<p>Controls the operation of the fascia mounted load switch control button (manual mode only)</p> <p><input type="checkbox"/> = The <i>Alternative Breaker Control Button</i> is disabled.</p> <p><input checked="" type="checkbox"/> = The <i>Alternative Breaker Control Button</i> is enabled.</p>

Parameter descriptions are continued overleaf...

Parameter	Description
Filter Mains Voltage Display	<p> <b>NOTE: The mains voltage is only filtered on the module's display and not on the SCADA or any other remote monitoring device.</b></p> <p><input type="checkbox"/> = The <i>Filter Mains Voltage Display</i> is disabled. The rate at which the mains voltage instruments are refreshed to display all voltage fluctuations.</p> <p><input checked="" type="checkbox"/> = The <i>Filter Mains Voltage Display</i> is enabled. The rate at which the mains voltage instruments are refreshed is configurable based on the <i>Filter Constant</i>. A larger <i>Filter Constant</i> leads to a slower refresh rate, filtering out the fluctuations on the mains voltage instruments.</p>

### 3.3.3 CONFIGURABLE FRONT PANEL EDITOR

The Configurable Front Panel Editor allows generator OEMs to create a PIN protected, customised Front Panel Editor with up to two security access levels. Items may be added or removed as required by the generator supplier.

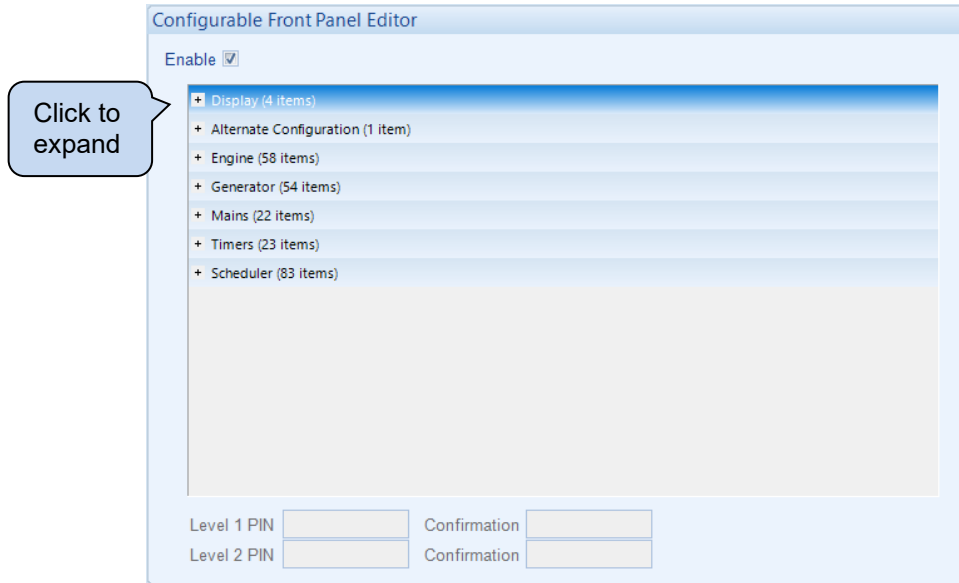

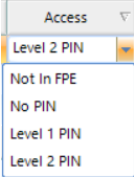
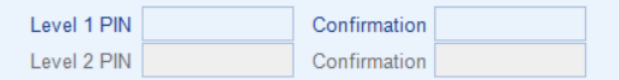
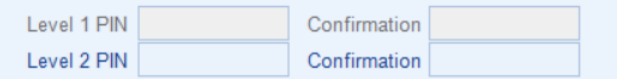
Items	Description
Enable	<input type="checkbox"/> = Configuration parameters are all accessible from Front Panel Editor. <input checked="" type="checkbox"/> = The Configuration parameters depend on their Access level.
Access	Permits the relevant item to be edited through the Front Panel Editor of the module.  <p><b>Not in FPE:</b> The item cannot be edited through the Front Panel Editor  <b>No PIN:</b> Allowing access to edit the item with no PIN  <b>Level 1 PIN:</b> The Front Panel Editor asks for the configured <i>Level 1 PIN</i> to allow access to the relevant item.  <b>Level 2 PIN:</b> The Front Panel Editor asks for the configured <i>Level 2 PIN</i> to allow access to the relevant item.</p>
Level 1 PIN	Set four-digit PIN number, then repeat the PIN in the <i>Confirmation</i> to configure <i>Level 1 PIN</i> for this access level. 
Level 2 PIN	<div style="border: 2px solid black; padding: 5px;"> <p><b>NOTE: Setting a <i>Level 2 Pin</i> also allows access to <i>Level 1</i> items.</b></p> </div> Set four-digit PIN number, then repeat the PIN in the <i>Confirmation</i> to configure <i>Level 2 PIN</i> for this access level. 

### 3.3.4 CONFIGURABLE INSTRUMENTATION DISPLAY

#### Displayed Instrumentation

Allows configuration of the modules display.

**Displayed Instrumentation**

<table style="width: 100%; border-collapse: collapse;"> <tr><td style="padding: 2px;">Instrument 1</td><td style="padding: 2px;">Not Used ▾</td></tr> <tr><td style="padding: 2px;">Instrument 2</td><td style="padding: 2px;">Not Used ▾</td></tr> <tr><td style="padding: 2px;">Instrument 3</td><td style="padding: 2px;">Not Used ▾</td></tr> <tr><td style="padding: 2px;">Instrument 4</td><td style="padding: 2px;">Not Used ▾</td></tr> <tr><td style="padding: 2px;">Instrument 5</td><td style="padding: 2px;">Not Used ▾</td></tr> <tr><td style="padding: 2px;">Instrument 6</td><td style="padding: 2px;">Not Used ▾</td></tr> <tr><td style="padding: 2px;">Instrument 7</td><td style="padding: 2px;">Not Used ▾</td></tr> <tr><td style="padding: 2px;">Instrument 8</td><td style="padding: 2px;">Not Used ▾</td></tr> <tr><td style="padding: 2px;">Instrument 9</td><td style="padding: 2px;">Not Used ▾</td></tr> <tr><td style="padding: 2px;">Instrument 10</td><td style="padding: 2px;">Not Used ▾</td></tr> <tr><td style="padding: 2px;">Instrument 11</td><td style="padding: 2px;">Not Used ▾</td></tr> <tr><td style="padding: 2px;">Instrument 12</td><td style="padding: 2px;">Not Used ▾</td></tr> <tr><td style="padding: 2px;">Instrument 13</td><td style="padding: 2px;">Not Used ▾</td></tr> <tr><td style="padding: 2px;">Instrument 14</td><td style="padding: 2px;">Not Used ▾</td></tr> <tr><td style="padding: 2px;">Instrument 15</td><td style="padding: 2px;">Not Used ▾</td></tr> <tr><td style="padding: 2px;">Instrument 16</td><td style="padding: 2px;">Not Used ▾</td></tr> </table>	Instrument 1	Not Used ▾	Instrument 2	Not Used ▾	Instrument 3	Not Used ▾	Instrument 4	Not Used ▾	Instrument 5	Not Used ▾	Instrument 6	Not Used ▾	Instrument 7	Not Used ▾	Instrument 8	Not Used ▾	Instrument 9	Not Used ▾	Instrument 10	Not Used ▾	Instrument 11	Not Used ▾	Instrument 12	Not Used ▾	Instrument 13	Not Used ▾	Instrument 14	Not Used ▾	Instrument 15	Not Used ▾	Instrument 16	Not Used ▾	<table style="width: 100%; border-collapse: collapse;"> <tr><td style="padding: 2px;">Instrument 17</td><td style="padding: 2px;">Not Used ▾</td></tr> <tr><td style="padding: 2px;">Instrument 18</td><td style="padding: 2px;">Not Used ▾</td></tr> <tr><td style="padding: 2px;">Instrument 19</td><td style="padding: 2px;">Not Used ▾</td></tr> <tr><td style="padding: 2px;">Instrument 20</td><td style="padding: 2px;">Not Used ▾</td></tr> <tr><td style="padding: 2px;">Instrument 21</td><td style="padding: 2px;">Not Used ▾</td></tr> <tr><td style="padding: 2px;">Instrument 22</td><td style="padding: 2px;">Not Used ▾</td></tr> <tr><td style="padding: 2px;">Instrument 23</td><td style="padding: 2px;">Not Used ▾</td></tr> <tr><td style="padding: 2px;">Instrument 24</td><td style="padding: 2px;">Not Used ▾</td></tr> <tr><td style="padding: 2px;">Instrument 25</td><td style="padding: 2px;">Not Used ▾</td></tr> <tr><td style="padding: 2px;">Instrument 26</td><td style="padding: 2px;">Not Used ▾</td></tr> <tr><td style="padding: 2px;">Instrument 27</td><td style="padding: 2px;">Not Used ▾</td></tr> <tr><td style="padding: 2px;">Instrument 28</td><td style="padding: 2px;">Not Used ▾</td></tr> <tr><td style="padding: 2px;">Instrument 29</td><td style="padding: 2px;">Not Used ▾</td></tr> <tr><td style="padding: 2px;">Instrument 30</td><td style="padding: 2px;">Not Used ▾</td></tr> <tr><td style="padding: 2px;">Instrument 31</td><td style="padding: 2px;">Not Used ▾</td></tr> <tr><td style="padding: 2px;">Instrument 32</td><td style="padding: 2px;">Not Used ▾</td></tr> </table>	Instrument 17	Not Used ▾	Instrument 18	Not Used ▾	Instrument 19	Not Used ▾	Instrument 20	Not Used ▾	Instrument 21	Not Used ▾	Instrument 22	Not Used ▾	Instrument 23	Not Used ▾	Instrument 24	Not Used ▾	Instrument 25	Not Used ▾	Instrument 26	Not Used ▾	Instrument 27	Not Used ▾	Instrument 28	Not Used ▾	Instrument 29	Not Used ▾	Instrument 30	Not Used ▾	Instrument 31	Not Used ▾	Instrument 32	Not Used ▾
Instrument 1	Not Used ▾																																																																
Instrument 2	Not Used ▾																																																																
Instrument 3	Not Used ▾																																																																
Instrument 4	Not Used ▾																																																																
Instrument 5	Not Used ▾																																																																
Instrument 6	Not Used ▾																																																																
Instrument 7	Not Used ▾																																																																
Instrument 8	Not Used ▾																																																																
Instrument 9	Not Used ▾																																																																
Instrument 10	Not Used ▾																																																																
Instrument 11	Not Used ▾																																																																
Instrument 12	Not Used ▾																																																																
Instrument 13	Not Used ▾																																																																
Instrument 14	Not Used ▾																																																																
Instrument 15	Not Used ▾																																																																
Instrument 16	Not Used ▾																																																																
Instrument 17	Not Used ▾																																																																
Instrument 18	Not Used ▾																																																																
Instrument 19	Not Used ▾																																																																
Instrument 20	Not Used ▾																																																																
Instrument 21	Not Used ▾																																																																
Instrument 22	Not Used ▾																																																																
Instrument 23	Not Used ▾																																																																
Instrument 24	Not Used ▾																																																																
Instrument 25	Not Used ▾																																																																
Instrument 26	Not Used ▾																																																																
Instrument 27	Not Used ▾																																																																
Instrument 28	Not Used ▾																																																																
Instrument 29	Not Used ▾																																																																
Instrument 30	Not Used ▾																																																																
Instrument 31	Not Used ▾																																																																
Instrument 32	Not Used ▾																																																																

Parameter	Description
Instrument 1 to 32	Select the instrumentation parameter that is to be displayed for the specific <i>Configurable Status Screen</i> .

### 3.3.5 EVENT LOG

#### Display Options

All events are configured and viewed in the *Event Log*.

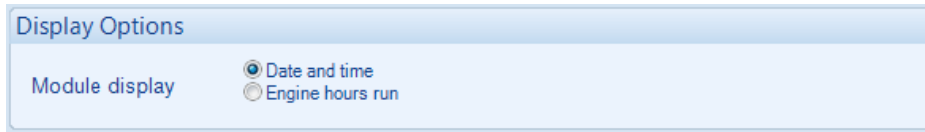

Parameter	Description
Module Display	<p><input checked="" type="radio"/> <b>Date and Time</b> = The module displays what the <i>Date and Time</i> was when the <i>Event</i> was logged.</p> <p><input type="radio"/> <b>Engine Hours Run</b> = The module displays what the <i>Engine Hours</i> was when the <i>Event</i> was logged.</p>

#### Logged Events

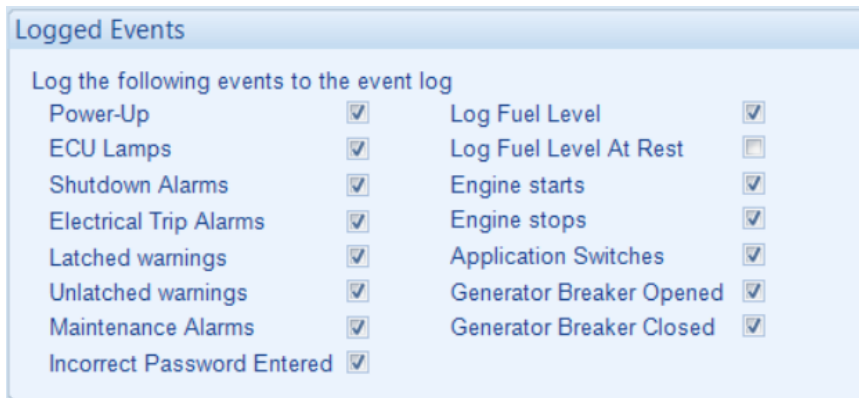

Parameter	Description
Power-Up	<p><input type="checkbox"/> = <i>Power-Up</i> events are not logged.</p> <p><input checked="" type="checkbox"/> = <i>Power-Up</i> events are logged when the DC Supply is applied to the module.</p>
ECU Lamps	<p><b>NOTE: ECU Alarms are only available when the module is configured to communicate to an engine's ECU/ECM over CANbus.</b></p> <p><input type="checkbox"/> = The ECU (ECM) alarm lamps signals are not logged.</p> <p><input checked="" type="checkbox"/> = The ECU (ECM) alarm lamps signals are logged when generated by the ECU (ECM)</p>
Shutdown Alarms	<p><input type="checkbox"/> = <i>Shutdown Alarms</i> are not logged.</p> <p><input checked="" type="checkbox"/> = <i>Shutdown Alarms</i> are logged when the moment they activate.</p>
Electrical Trip Alarms	<p><input type="checkbox"/> = <i>Electrical Trip Alarms</i> are not logged.</p> <p><input checked="" type="checkbox"/> = <i>Electrical Trip Alarms</i> are logged when the moment they activate.</p>
Latched Warnings	<p><input type="checkbox"/> = <i>Latched Warnings Alarms</i> are not logged.</p> <p><input checked="" type="checkbox"/> = <i>Latched Warnings Alarms</i> are logged when the moment they activate.</p>
Unlatched Warnings	<p><input type="checkbox"/> = <i>Unlatched Warnings Alarms</i> are not logged.</p> <p><input checked="" type="checkbox"/> = <i>Unlatched Warnings Alarms</i> are logged when the moment they activate.</p>
Maintenance Alarms	<p><input type="checkbox"/> = <i>Maintenance Alarms</i> are not logged.</p> <p><input checked="" type="checkbox"/> = <i>Maintenance Alarms</i> are logged when the moment they activate.</p>

Parameter descriptions are continued overleaf...

Parameter	Description
Log Fuel Level	<input type="checkbox"/> = <i>Fuel Monitoring</i> events are not logged when the generator running. Fuel level alarms are still logged if the appropriate alarm category is logged. <input checked="" type="checkbox"/> = <i>Fuel Monitoring</i> events are logged when the generator is running.
Log Fuel Level at Rest	<input type="checkbox"/> = <i>Fuel Monitoring</i> events are not logged when the generator is at rest. Fuel level alarms are still logged if the appropriate alarm category is logged. <input checked="" type="checkbox"/> = <i>Fuel Monitoring</i> events are logged when the generator is at rest.
Engine Starts	<input type="checkbox"/> = <i>Engine Start</i> events are not logged. <input checked="" type="checkbox"/> = <i>Engine Start</i> events are logged when the generator successfully crank disconnects.
Engine Stops	<input type="checkbox"/> = <i>Engine Stop</i> events are not logged. <input checked="" type="checkbox"/> = <i>Engine Stop</i> events are when the <i>Stopping Timer</i> ceases.
Application Switches	<input type="checkbox"/> = Application Switch events are not logged. <input checked="" type="checkbox"/> = Application Switch events are logged when the application is switched between <i>Single Set</i> and <i>Multi Set</i> modes.
Generator Breaker Opened	<input type="checkbox"/> = Generator Breaker Open events are not logged. <input checked="" type="checkbox"/> = Generator Breaker Open events are logged when the generator breaker is successfully opened.
Generator Breaker Closed	<input type="checkbox"/> = Generator Breaker Closed events are not logged. <input checked="" type="checkbox"/> = Generator Breaker Closed events are logged when the generator breaker is successfully closed.
Incorrect Password Entered	<input type="checkbox"/> = Incorrect Password Entered events are not logged. <input checked="" type="checkbox"/> = Incorrect Password Entered events are logged when a password is entered incorrectly.

**Logged Events (Single Set)**

All *Single Set* events are configured and viewed in the *Event Log*.

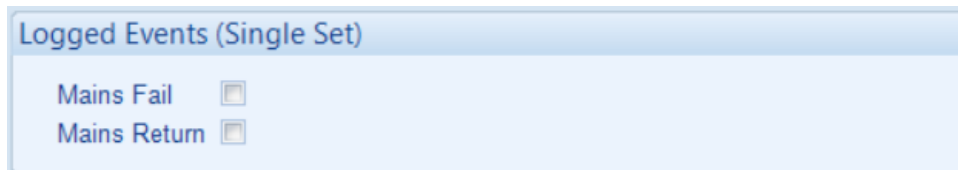

Parameter	Description
Mains Fail	<input type="checkbox"/> = <i>Mains Fail</i> events are not logged. <input checked="" type="checkbox"/> = <i>Mains Fail</i> events are logged when the mains voltage or frequency rises above or falls below the configured trip levels for the duration of the <i>Mains Transient Delay</i> timer.
Mains Return	<input type="checkbox"/> = <i>Mains Return</i> events are not logged. <input checked="" type="checkbox"/> = <i>Mains Return</i> events are logged when the mains returns within the configured Mains Voltage/Frequency range for both <i>Transient Delay Timer</i> and the <i>Return Delay Timer</i> .

**Logging Options**

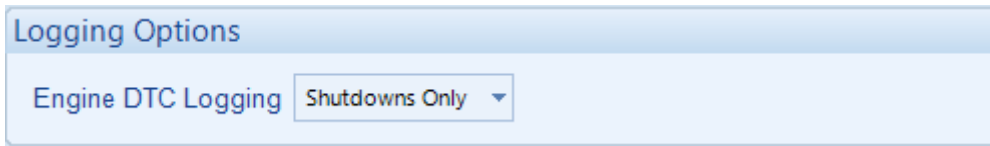

Logging Options

Engine DTC Logging Shutdowns Only

Parameter	Description
Always	When selected, DTCs are immediately logged upon occurrence
Never	Select to disable Engine DTC logging
Shutdowns and Warnings	When selected, Engine DTCs are logged when an ECU Shutdown or ECU Warning occurs, the timestamp for the DTC in the event log is that of the Shutdown or Warning
Shutdowns Only	When selected, Engine DTCs are logged when an ECU Shutdown occurs, the timestamp for the DTC in the event log is that of the Shutdown

### 3.3.6 DATA LOGGING

The *Data Logging* section is subdivided into smaller sections.

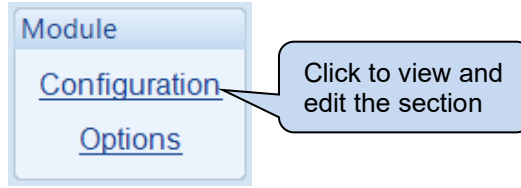

The module is able to record up to twenty parameters and is saved as a *Data Log File* to the module's internal memory or an external USB storage device. If 20 parameters were configured to be logged, each with a *Log Interval* of 1 second, the length of each *Data Log File* would be 6 hours and 21 minutes. This time is extendable as the length of each *Data Log File* varies upon the number of selected parameters and their configured *Log Interval*.

The module is able to store 128 *Data Log Files* to its internal memory. The number of *Data Log Files* increases when an external USB storage device is connected to the module's USB Host port. The increased number of *Data Log Files* is dependent upon the size of the USB storage device connected. When using the maximum size USB storage device of 16 GB, the number of *Data Log Files* is increased to 8200. This results in a total *Data Log* length of 46 weeks, 2 days, 6 hours, and 24 minutes (assuming 20 parameters were configured to be logged, each with a *Log Interval* of 1 second).

The *Data Logging* is viewed using the *Data Log Viewer* application, which is accessed from the DSE Configuration Suite PC Software under the *Tools* menu.

3.3.6.1 CONFIGURATION

**Data Logging**

	Logged data	Log Interval
1	DC Power On	1 minute
	Generator Total Power	1 second
	Generator Current L1	1 second
4	Generator Volts (L1-N)	1 second
5	<Not Used>	1 second
6	<Not Used>	1 minute
7	<Not Used>	1 minute
8	<Not Used>	1 second
9	<Not Used>	1 second
10	<Not Used>	1 second
11	<Not Used>	1 second
12	<Not Used>	1 second
13	<Not Used>	1 second
14	<Not Used>	1 second
15	<Not Used>	1 second
16	<Not Used>	1 second
17	<Not Used>	1 second
18	<Not Used>	1 second
19	<Not Used>	1 second
20	<Not Used>	1 second

**Click to select data to be logged**

**Click to select time interval**

Parameter	Description
Logged Data	Select the item required to be logged. Data is logged from a Specific Register, Alarms, Control, Instrumentation, or a Status item.
Log Interval	Select the logging interval of the data: 1 second to 24 hrs

3.3.6.2 OPTIONS



Parameter	Description
Only Log When Engine is Running	<input type="checkbox"/> = The module logs data regardless of engine running state. <input checked="" type="checkbox"/> = The module only logs data when the engine is running.
Log to USB Drive	<input type="checkbox"/> = The module logs data to the module's internal memory. <input checked="" type="checkbox"/> = The module logs data to an external USB memory device connect to the USB host socket on the module.
Keep Oldest Data	<input type="checkbox"/> = When the logging memory is full, the module overwrites the oldest data first with the new data. <input checked="" type="checkbox"/> = When the logging memory is full, the module stops recording new data.

### 3.4 INPUTS

The *Inputs* section is subdivided into smaller sections.  
Select the required section with the mouse.

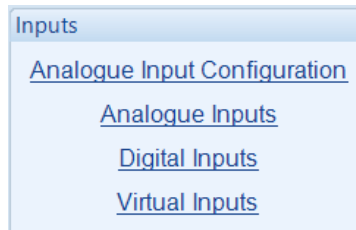

#### 3.4.1 ANALOGUE INPUT CONFIGURATION

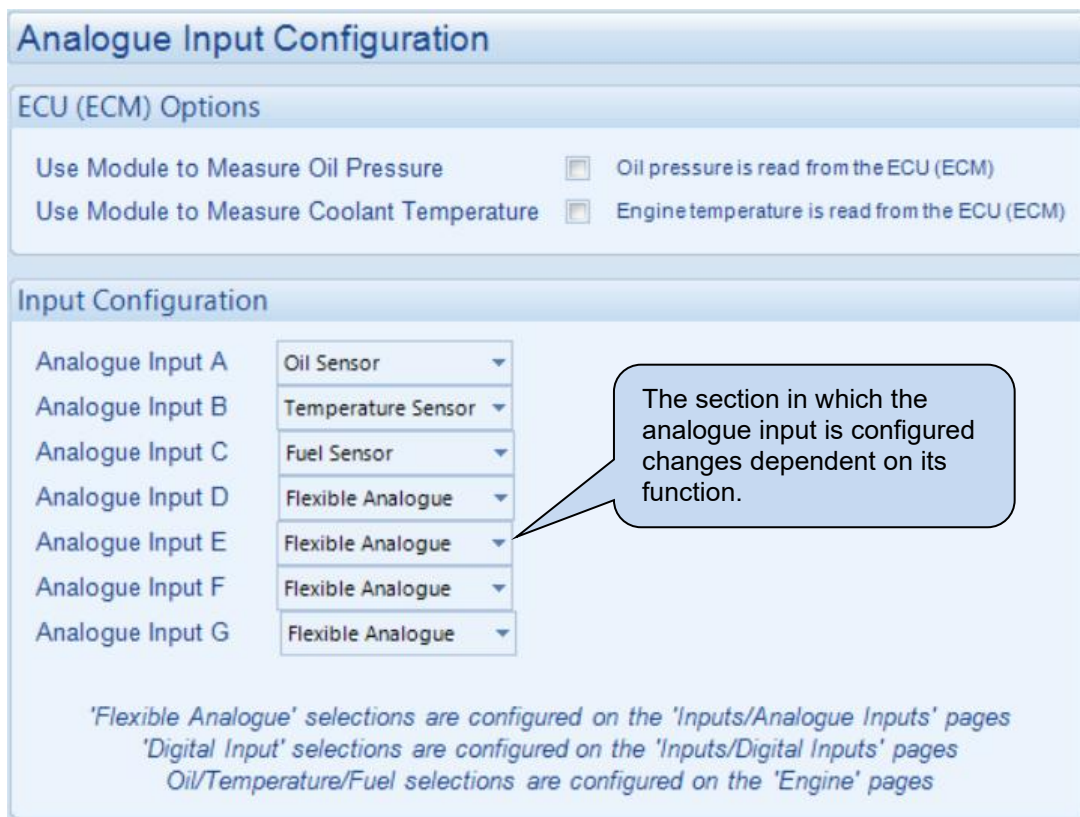

#### ECU (ECM) Options

Parameter	Description
Use Module to Measure Oil Pressure	(Available only when the module is configured for connection to a CAN engine.) <input type="checkbox"/> = The measurements are taken from the ECU (ECM). <input checked="" type="checkbox"/> = The module ignores the CAN measurement and uses the analogue sensor input.
Use Module to Measure Coolant Temperature	(Available only when the module is configured for connection to a CAN engine.) <input type="checkbox"/> = The measurements are taken from the ECU. <input checked="" type="checkbox"/> = The module ignores the CAN measurement and uses the analogue sensor input.

Parameter descriptions are continued overleaf...

**Input Configuration**

<b>Parameter</b>	<b>Description</b>
Analogue Input A	Select what the analogue input is to be used for: <b>Not Used:</b> The analogue input is disabled <b>Digital Input:</b> Configured on the <i>Inputs/Digital Inputs</i> pages <b>Flexible Analogue:</b> Configured on the <i>Inputs/Analogue Inputs</i> pages <b>Oil Sensor:</b> Configured on the Engine pages
Analogue Input B	Select what the analogue input is to be used for: <b>Not Used:</b> The analogue input is disabled <b>Digital Input:</b> Configured on the <i>Inputs/Digital Inputs</i> pages <b>Flexible Analogue:</b> Configured on the <i>Inputs/Analogue Inputs</i> pages <b>Temperature Sensor:</b> Configured on the Engine pages
Analogue Input C	Select what the analogue input is to be used for: <b>Not Used:</b> The analogue input is disabled <b>Digital Input:</b> Configured on the <i>Inputs/Digital Inputs</i> pages <b>Flexible Analogue:</b> Configured on the <i>Inputs/Analogue Inputs</i> pages <b>Fuel Sensor:</b> Configured on the Engine pages
Analogue Input D	Select what the analogue input is to be used for: <b>Not Used:</b> The analogue input is disabled <b>Digital Input:</b> Configured on the <i>Inputs/Digital Inputs</i> pages <b>Flexible Analogue:</b> Configured on the <i>Inputs/Analogue Inputs</i> pages
Analogue Input E	Select what the analogue input is to be used for: <b>Not Used:</b> The analogue input is disabled <b>Digital Input:</b> Configured on the <i>Inputs/Digital Inputs</i> pages <b>Flexible Analogue:</b> Configured on the <i>Inputs/Analogue Inputs</i> pages
Analogue Input F	Select what the analogue input is to be used for: <b>Not Used:</b> The analogue input is disabled <b>Digital Input:</b> Configured on the <i>Inputs/Digital Inputs</i> pages <b>Flexible Analogue:</b> Configured on the <i>Inputs/Analogue Inputs</i> pages
Analogue Input G	Select what the analogue input is to be used for: <b>Not Used:</b> The analogue input is disabled <b>Digital Input:</b> Configured on the <i>Inputs/Digital Inputs</i> pages <b>Flexible Analogue:</b> Configured on the <i>Inputs/Analogue Inputs</i> pages

### Configuring an Analogue Input as a Digital Input

Analogue inputs are configured as a Digital Input.

**Analogue Input A (Digital)**

The Analogue Input is not configured as a Digital Input  
To reconfigure, use the 'Analogue Input Configuration' page

Select the required Analogue Input from A to G

**Input Configuration**

Analogue Input A	Digital Input
Analogue Input B	Temperature Sensor
Analogue Input C	Fuel Sensor
Analogue Input D	Flexible Analogue
Analogue Input E	Flexible Analogue
Analogue Input F	Flexible Analogue
Analogue Input G	Flexible Analogue

*'Flexible Analogue' selections are configured on the 'Inputs/Analogue Inputs' pages  
'Digital Input' selections are configured on the 'Inputs/Digital Inputs' pages  
Oil/Temperature/Fuel selections are configured on the 'Engine' pages*

*In this example Analogue Input A is selected as a Digital Input*

☐ Digital Inputs

- Digital Inputs A - C
- Digital Inputs D - F
- Digital Inputs G - I
- Analogue Inputs A - C**
- Analogue Inputs D - F
- Analogue Input G

Select the corresponding Analogue Input on the Digital Input page.

**Analogue Input A (Digital)**

Function: User Configured  
Polarity: Close to Activate  
Action: Warning  
Arming: Always

LCD Display: Analogue Input A (Digital)  
Activation Delay: 0s

**Analogue Input B (Digital)**

The Analogue Input is not configured as a Digital Input  
To reconfigure, use the 'Analogue Input Configuration' page

**Analogue Input C (Digital)**

The Analogue Input is not configured as a Digital Input  
To reconfigure, use the 'Analogue Input Configuration' page

*Analogue Input A is now a Digital Input*

### 3.4.2 ANALOGUE INPUTS

**NOTE:** An analogue input is only configurable as a flexible sensor if it has been configured as *Flexible Analogue*. For further details refer to the section entitled *Analogue Input Configuration* elsewhere in this document.

#### Analogue Inputs

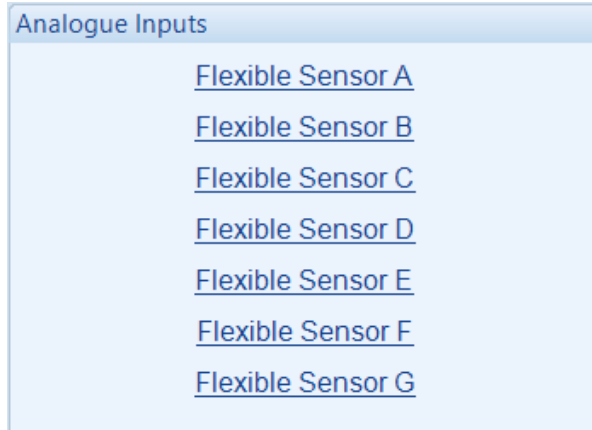

A screenshot of a software window titled "Analogue Inputs". The window has a light blue header and contains a list of seven items, each with a blue underlined text: "Flexible Sensor A", "Flexible Sensor B", "Flexible Sensor C", "Flexible Sensor D", "Flexible Sensor E", "Flexible Sensor F", and "Flexible Sensor G".

#### Sensor Description

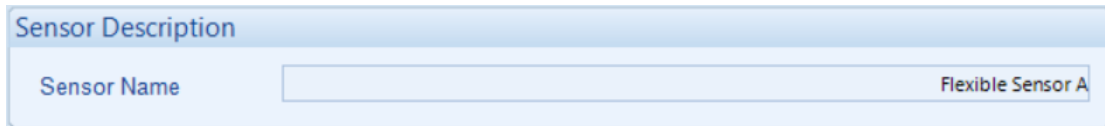

A screenshot of a software window titled "Sensor Description". It features a light blue header and a text input field. The label "Sensor Name" is positioned to the left of the input field, and the text "Flexible Sensor A" is visible inside the field.

Parameter	Description
Sensor Name	Enter the <i>Sensor Name</i> , this text is shown on the module display when viewing the instrument.

**Input Type**

Parameter	Description
1st Stage Curve	<p>Select the sensor type and curve from a pre-defined list or create a user-defined curve. Available sensor types:</p> <p><b>Not Used:</b> The input is not used  <b>Current:</b> for sensors with maximum range of 0 mA to 20 mA  <b>Resistive:</b> for sensors with maximum range of 0 Ω to 3 k Ω  <b>Voltage:</b> for sensors A-D with maximum range of 0 V to 10 V  <b>Voltage:</b> for sensors E-G with maximum range of 0 V to 32 V                      Available parameters to be measured:  <b>Pressure:</b> The input is configured as a pressure sensor  <b>Percentage:</b> The input is configured as a percentage sensor  <b>Temperature:</b> The input is configured as a temperature sensor  <b>User Defined:</b> Using the curve editor</p>
2nd Stage curve	<p>Select the optional curve used to plot a secondary unit against percentage. Available units:</p> <p><b>Not Used:</b> The input is not used.  <b>Percentage:</b> The secondary stage curves Y-Axis is configured as percentage.  <b>Pressure:</b> The secondary stage curves Y-Axis is configured as pressure.  <b>Temperature:</b> The secondary stage curves Y-Axis is configured as temperature.  <b>User Defined:</b> Pounds per Square Inch (PSI)</p>

**Sensor Fault Alarm**

Parameter	Description
Enable Alarm	<input type="checkbox"/> = The Alarm is disabled. <input checked="" type="checkbox"/> = The <i>Sensor Fault Alarm</i> is enabled once a <i>Sensor Alarm</i> is enabled.
Alarm String	The text that is displayed on the module's LCD when the <i>Sensor Fault Alarm</i> activates.

**Sensor Alarms**

Parameter	Description
Alarm Arming	<b>▲ NOTE: For details of these, see the section entitled <i>Alarm Arming</i> elsewhere in this document.</b>  Select when the alarm generated by the analogue input becomes active: <b><i>Always</i></b> <b><i>From Safety On</i></b> <b><i>From Starting</i></b>
Low Alarm Enable	<input type="checkbox"/> = The Alarm is disabled. <input checked="" type="checkbox"/> = The <i>Low Alarm</i> activates when the measured quantity drops below the <i>Low Alarm</i> setting.
Low Alarm Action	<b>▲ NOTE: For details of these, see the section entitled <i>Alarm Types</i> elsewhere in this document.</b>  Select the type of alarm required from the list: <b><i>Electrical Trip</i></b> <b><i>Shutdown</i></b>

Parameter descriptions are continued overleaf...

*Editing the Configuration*

Parameter	Description
Low Pre-Alarm Enable	<input type="checkbox"/> = The Pre-Alarm is disabled. <input checked="" type="checkbox"/> = The <i>Low Pre-Alarm</i> is active when the measured quantity drops below the <i>Low Pre-Alarm Trip</i> setting. The <i>Low Pre-Alarm</i> is automatically reset when the measured quantity rises above the configured <i>Low Pre-Alarm Return</i> level.
Low Alarm String	The text that is displayed on the module's LCD when the <i>Low Alarm</i> or <i>Low Pre-Alarm</i> activates.
High Pre-Alarm Enable	<input type="checkbox"/> = The Pre-Alarm is disabled. <input checked="" type="checkbox"/> = The <i>High Pre-Alarm</i> is active when the measured quantity rises above the <i>High Pre-Alarm Trip</i> setting. The <i>High Pre-Alarm</i> is automatically reset when the measured quantity falls below the configured <i>High Pre-Alarm Return</i> level.
High Alarm Enable	<input type="checkbox"/> = The Alarm is disabled. <input checked="" type="checkbox"/> = The <i>High Alarm</i> is active when the measured quantity rises above the <i>High Alarm</i> setting.
High Alarm Action	<div style="border: 1px solid black; padding: 5px;"> <p> <b>NOTE: For details of these, see the section entitled <i>Alarm Types</i> elsewhere in this document.</b></p> </div> <p>Select the type of alarm required from the list:  <b><i>Electrical Trip</i></b>  <b><i>Shutdown</i></b></p>
High Alarm String	The text that is displayed on the module's LCD when the <i>High Alarm</i> or <i>High Pre-Alarm</i> activates.

### 3.4.2.1 CREATING / EDITING THE SENSOR CURVE

While the *DSE Configuration Suite* holds sensor specifications for the most used resistive sensors, occasionally it is required that the module be connected to a sensor not listed by the *DSE Configuration Suite*. To aid this process, a sensor curve editor is provided.

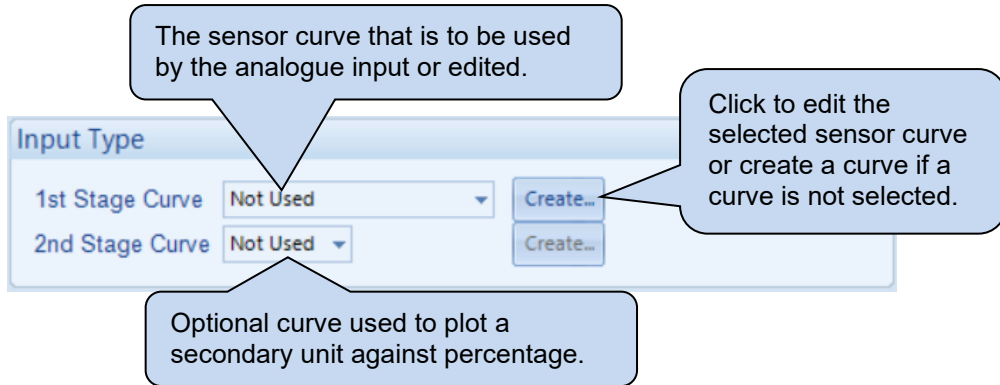

When creating a new sensor curve the measurement quantity and measured parameter are required.

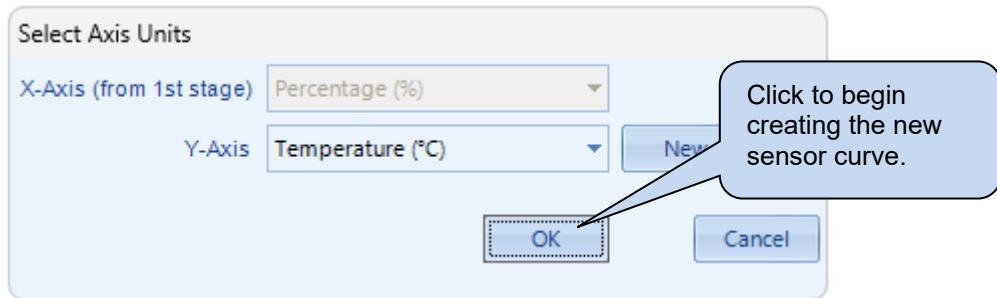

Parameter	Description
X-Axis (Measured Quantity)	Select the electrical quantity that the sensor outputs. <b>Current (mA)</b> : For sensors that output current within a range 0 mA to 20 mA <b>Voltage (0-10 Volts)</b> : For sensors that output voltage within a range of 0 V to 10 V <b>Voltage (0-32 Volts)</b> : For sensors that output voltage within a range of 0 V to 32 V <b>Resistive (Ohms)</b> : For sensors that output a resistance within a range 0 Ω to 3K Ω on Analogue Input A and 0 to 5K Ω on Analogue Inputs B to G
Y-Axis	Select the parameter that is being monitored by the sensor. <b>Temperature (°C)</b> : For sensors that measure temperature. <b>Pressure (Bar)</b> : For sensors that measure pressure. <b>Percentage (%)</b> : For sensors that measure percentage.

Sensor curve creation and editor descriptions are continued overleaf...

## Editing the Configuration

Curve Editor

<Unnamed Curve>

Display Temperature in: °C

Click and drag the points on the graphs to change the settings

Click to change the Y axis value between imperial and metric units.

Double click the left mouse button to add a point or right click on a point to remove it.

The red highlighted area indicates under measurable range.

Use the mouse to select the graph point, then enter the value in the box or click up/down to change the value

The red highlighted area indicates over measurable range.

Click *Interpolate* then select two points as prompted to draw a straight line between them.

Click to change the range of the X and Y Axes of the graph and the level of open circuit

Click Save As prompt to name the curve...

Click OK to accept the changes or CANCEL to ignore and lose the

Click OK to save the curve.

**Any saved curves become selectable in the *Input Type* selection list.**

**Hint:** Deleting, renaming, or editing custom sensor curves that have been added is performed in the main menu, select *Tools | Curve Manager*.

Number of points used: 5/31

**Change Axis Range**

**NOTE:** The difference between the Minimum and Maximum values on the X and Y axis must exceed the noted limits.

The screenshot shows a 'Select Range' dialog box with a graph and configuration fields. The graph plots percentage (%) on the Y-axis (0 to 250) against Ohms on the X-axis (0 to 450). A blue line with four data points shows a linear relationship. Below the graph are three rows of configuration fields: 'X-Axis(Ohms)', 'Y-Axis(%)', and 'X Axis - Fault Threshold'. Each row has 'Minimum' and 'Maximum' columns with spinners and text boxes. The 'X-Axis(Ohms)' row has a minimum of 0 and a maximum of 480, with a note 'X-Axis range must exceed 200 Ohms'. The 'Y-Axis(%)' row has a minimum of 0 and a maximum of 260, with a note 'Y-Axis range must exceed 200 %'. The 'X Axis - Fault Threshold' row has a minimum of 0 and a maximum of 5000. Callouts provide additional context: 'The X Axis is either Volts, mA or Ohms depending on what type of sensor is edited.' points to the 'X-Axis(Ohms)' label; 'The Y Axis is either %, Bar or ° C depending on what type of sensor is edited.' points to the 'Y-Axis(%)' label; and 'The maximum X Axis Fault Threshold limit.' points to the '5000' value in the 'X Axis - Fault Threshold' maximum field. 'OK' and 'Cancel' buttons are at the bottom.

Parameter	Minimum	Maximum	Notes
X-Axis(Ohms)	0	480	X-Axis range must exceed 200 Ohms
Y-Axis(%)	0	260	Y-Axis range must exceed 200 %
X Axis - Fault Threshold	0	5000	The maximum X Axis Fault Threshold limit.

### 3.4.3 DIGITAL INPUTS

The *Digital Inputs* section is subdivided into smaller sections. Select the required section with the mouse.

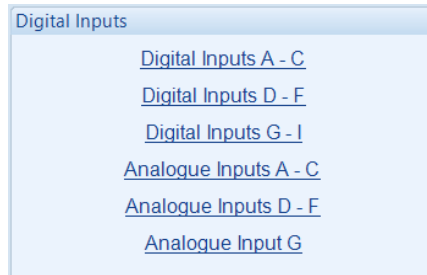

#### 3.4.3.1 DIGITAL INPUTS

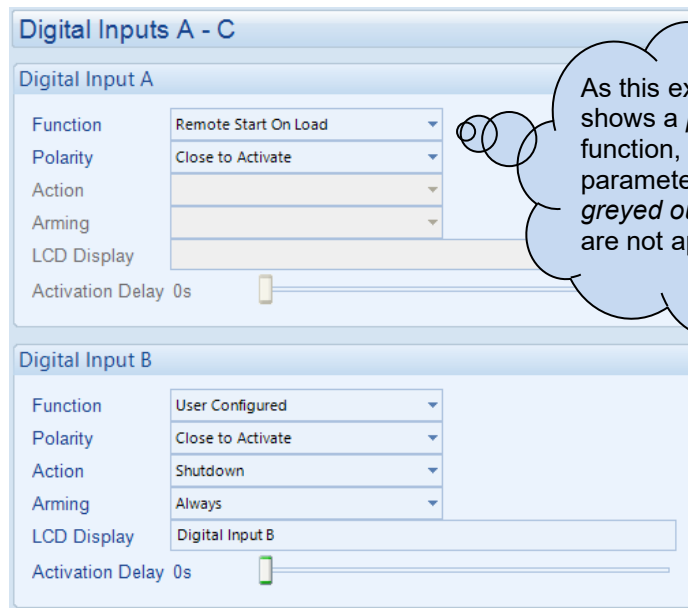

As this example shows a *predefined* function, these parameters are *greyed out* as they are not applicable.

Parameter	Description
Function	Select the input function to activate when the relevant terminal is energised. See the section entitled <i>Input Functions</i> for details of all available functions elsewhere in this document.
Polarity	Select the digital input polarity: <b>Close to Activate:</b> the input function is activated when the relevant terminal is connected. <b>Open to Activate:</b> the input function is activated when the relevant terminal is disconnected.
Action	<div style="border: 2px solid black; padding: 5px; margin-bottom: 5px;"> <p><b>⚠ NOTE: For details of these, see the section entitled <i>Alarm Types</i> elsewhere in this document.</b></p> </div> <p>Select the type of alarm required from the list:  <b>Electrical Trip</b>  <b>Indication</b>  <b>Shutdown</b>  <b>Warning</b></p>

Parameter descriptions are continued overleaf...

Parameter	Description
Arming	<div style="border: 1px solid black; padding: 2px; margin-bottom: 5px;">  <b>NOTE: For details of these, see the section entitled <i>Alarm Arming</i> elsewhere in this document.</b> </div> <p>Select when the alarm generated by the input becomes active:  <b><i>Active from Mains Parallel</i></b>  <b><i>Always</i></b>  <b><i>From Safety On</i></b>  <b><i>From Starting</i></b>  <b><i>Never</i></b></p>
LCD Display	The text that is displayed on the module's LCD when the input activates and generates an alarm.
Activation Delay	This is used to give a delay on acceptance of the input. Useful for liquid level switches or to mask short term operations of the external switch device.

### 3.4.3.2 ANALOGUE INPUTS

**NOTE:** An analogue input is only configurable as a digital input if it has been configured as *Digital Input*, for further details refer to the section entitled *Analogue Input Configuration* elsewhere in this document.

#### Analogue Inputs

##### Analogue Input A (Digital)

Function	User Configured
Polarity	Close to Activate
Action	Warning
Arming	Always
LCD Display	Analogue Input A (Digital)
Activation Delay 0s	<input type="range"/>

##### Analogue Input B (Digital)



The Analogue Input is not configured as a Digital Input  
To reconfigure, use the 'Analogue Input Configuration' page

Parameter	Description
Function	Select the input function to activate when the relevant terminal is energised. See the section entitled <i>Input Functions</i> for details of all available functions elsewhere in this document.
Polarity	Select the digital input polarity: <b>Close to Activate:</b> the input function is activated when the relevant terminal is connected. <b>Open to Activate:</b> the input function is activated when the relevant terminal is disconnected.
Action	<div style="border: 2px solid black; padding: 5px; margin-bottom: 5px;"> <p><b>NOTE:</b> For details of these, see the section entitled <i>Alarm Types</i> elsewhere in this document.</p> </div> <p>Select the type of alarm required from the list: <b>Electrical Trip</b> <b>Indication</b> <b>Shutdown</b> <b>Warning</b></p>
Arming	<div style="border: 2px solid black; padding: 5px; margin-bottom: 5px;"> <p><b>NOTE:</b> For details of these, see the section entitled <i>Alarm Arming</i> elsewhere in this document.</p> </div> <p>Select when the alarm generated by the input becomes active: <b>Active from Mains Parallel</b> <b>Always</b> <b>From Safety On</b> <b>From Starting</b> <b>Never</b></p>
LCD Display	The text that is displayed on the module's LCD when the input activates and generates an alarm.
Activation Delay	This is used to give a delay on acceptance of the input. Useful for liquid level switches or to mask short term operations of the external switch device.



### 3.4.3.3 INPUT FUNCTIONS

Where a digital input is NOT configured as “user configured,” a selection is made from a list of predefined functions. The selections are as follows:

Under the scope of IEEE C37.2, function numbers are also used to represent functions in microprocessor devices and software programs. Where the DSE input functions are represented by IEEE C37.2, the function number is listed below.

Function	Description
User Configured	This input is used to generate a custom alarm using the configured <i>Action</i> , <i>Arming</i> and <i>LCD Display</i> items.
3 Wire start Integrity	This input is the complementary input to the ‘remote start on load’ digital input. It must be used when 3 wire start is enabled and must be the opposite state to the ‘remote start on load’ input.
Air Flap Closed Auxiliary IEEE C37.2 - 3 Checking or Interlocking Relay	This input is used to connect to the air flap switch contacts. This gives an immediate shutdown in the event of the air flap being closed. It also prevents the generator from being restarted if the air flap has not been reset following an over-speed shutdown.
Alarm Mute	This input is used to silence the audible alarm from an external source, such as a remote mute switch.
Alarm Reset	This input is used to reset any latched alarms from a remote location. It is also used to clear any latched warnings which may have occurred (if configured) without having to stop the generator.
Alt Config 1 – 5 Select	These inputs are used to instruct the module to follow the relevant <i>alternative</i> configuration settings instead of the <i>main</i> configuration settings.
AMSC Alarms Inhibit (Multi Set)	<div style="border: 1px solid black; padding: 5px;">  <b>NOTE: The AMSC Old Version alarm is not inhibited when this input is active.</b> </div> <p>If this input is active, all AMSC failure related alarms are inhibited from activating even if the fault is active.</p>
Auto Restore Inhibit (Single Set)	In the event of a Single Set Controller detecting a mains failure, the generator is instructed to start and take load. When the Single Set controller detects the mains has returned the module continues to run the generator on load until the <i>Auto Restore Inhibit</i> input is removed. This input allows the controller to be fitted as part of a system where the restoration to mains is controlled remotely, by an automated or by onsite personnel.
Auto Run Inhibit IEEE C37.2 - 3 Checking or Interlocking Relay	<div style="border: 1px solid black; padding: 5px;">  <b>NOTE: This input does not prevent the generators starting and running in Manual mode.</b> </div> <p>This input is used to provide an over-ride function to prevent the controller from starting and/or running the generator in the event of any active start signal. If this input is active the module does not give a start command to the generator. If the generator is running when this signal is activated the controller begins the controlled shutdown sequence. If this generator is part of a load demand scheme the load would be ramped off first, which may cause another generator to start if one is available. If this input signal is then removed, the controller operates normally and responds to a start signal. This input does not prevent starting of the generator in manual mode.</p>

Parameter descriptions are continued overleaf...

Function	Description
Auto Start Inhibit IEEE C37.2 - 3 Checking or Interlocking Relay	<p> <b>NOTE: This input does not prevent the generators starting in Manual mode.</b></p> <p>This input is used to provide an over-ride function to prevent the controller from starting the generator in the event of a Multi Set Controller/Mains out of limits condition occurring. If this input is active and a Multi Set Controller signal/Mains failure occurs the module does not give a start command to the generator. If this input signal is then removed, the controller operates as if a Multi Set Controller/Mains failure has occurred, starting, and loading the generator. If the 'Auto start Inhibit' signal becomes active when the generators are running, this input is ignored and does not stop because of it. This input does not prevent starting of the Generator Bus in MANUAL mode.</p>
Auxiliary Mains Fail (Single Set)	The module monitors the incoming single or three phase supply for Over voltage, Under Voltage, Over Frequency or Under frequency. It may be required to monitor a different mains supply, or some aspect of the incoming mains not monitored by the controller. If the devices providing this additional monitoring are connected to operate this input, the controller operates as if the incoming mains supply has fallen outside of limits, the generator is instructed to start and take the load. Removal of the input signal causes the module to act if the mains has returned to within limits providing that the mains sensing also indicates that the mains is within limits.
Clear Mains Decoupling Alarms	This input is used to reset the module following a Mains Decoupling Alarm (ROCOF, vector shift, Mains Voltage Alarm, Mains Frequency Alarm). The input must switch from inactive to active to reset the trip, it is not to be left permanently active.
Coolant Temperature Switch IEEE C37.2 – 26 Apparatus Thermal Device	This input is used to give a <i>Coolant Temperature High</i> shutdown from a digital normally open or closed switch. It allows coolant temperature protection.
Disable Fault Ride Through	<p> <b>NOTE: Disabling this feature can lead to increased electrical trips, loss of stability, frequency collapse, higher maintenance costs,</b></p> <p>This input is used to disable the <i>Fault Ride Through</i> setting.</p>
Disable Mains Decoupling QU Alarm	This input allows external control over the activation of the Mains Decoupling QU Alarm. When asserted, it disables the alarm notification associated with the QU protection function.
Disable Protections	The system designer provides this switch (not DSE), so its location varies depending upon manufacturer, however it normally takes the form of a key operated switch to prevent inadvertent activation. Depending upon configuration, a warning alarm is generated when the switch is operated. When active, and the module is suitably configured (see the section entitled <i>Advanced Options</i> elsewhere in this document) this prevents the engine being stopped upon critical alarm (Sometimes called Battle-Short Mode, War Mode or Run to Destruction).
DPF Auto Regen Inhibit	This input is used to override the ECU (ECM) function and prevent the automatic regeneration of the diesel particulate filter.
DPF Force Regeneration	This input is used to override the ECU (ECM) function and activate the regeneration of the diesel particulate filter.
DPF Regeneration Interlock	This input is used to stop a manual regeneration from occurring.

Parameter descriptions are continued overleaf...

*Editing the Configuration*

<b>Function</b>	<b>Description</b>
Droop ECU Enable	This input is used to enable the droop function on a supported ECU/ECM that is fitted to the engine. It is not to be confused with Governor or AVR droop.
Duty Select (Multi Set) IEEE C37.2 - 10 Unit Sequence Switch	This input is used to force the appropriate set to become the duty set when using a load demand scheme. Irrespective of the priority number configured in the module, it is forced to become the priority set. This allows for manual duty selection, overriding the automatic system normally used by the modules.
EJP1	For the French EJP (Effacement Jours de Pointe) tariff system.  This input is functionally identical to <i>Multi Set Controller Off Load</i> . When this input is active, operation is like the 'Multi Set Controller on load' function except that the generator is not instructed to take the load. This function is also used where an engine only run is required e.g., for exercise.
EJP2	For the French EJP (Effacement Jours de Pointe) tariff system.  This input is functionally identical to <i>Multi Set Controller On Load</i> . In <i>Auto Mode</i> , the module performs the start sequence and transfers load to the generator. In <i>Manual mode</i> , the load is transferred to the generator if the engine is already running, however in manual mode, this input does not generate start/stop requests of the engine.
Enable AVR Digital Droop (Multi Set)	This input is used to enable the AVR digital droop control using the G8600 controller (while running in kvar share+droop) in Reactive Load Control Mode.
Enable Governor Digital Droop (Multi Set)	This input uses system frequency to manage load share instead of AMSC on a supported ECU/ECM that is fitted to the engine.
Enable Power Mode 1 Constant Power (Default)	This input is used to instruct the module to switch to <i>Power Mode 1 Constant Power (Default)</i>
Enable Power Mode 2 Frequency-Power	This input is used to instruct the module to switch to <i>Power Mode 2 Frequency-Power</i>
Enable Power Mode 3 Voltage-Power	This input is used to instruct the module to switch to <i>Power Mode 3 Voltage-Power</i>
Enable Power Mode 4 VDE Frequency Power	This input is used to instruct the module to switch to <i>Power Mode 4 VDE Frequency-Power</i> .
Enable Reactive Mode 1 Constant Power Factor	This input is used to instruct the module to switch to <i>Reactive Mode 1 Constant Power Factor</i>
Enable Reactive Mode 2 Voltage-Reactive Power	This input is used to instruct the module to switch to <i>Reactive Mode 2 Voltage-Reactive Power</i>
Enable Reactive Mode 3 Power-Power Factor	This input is used to instruct the module to switch to <i>Reactive Mode 3 Power-Power Factor</i>
Enable Reactive Mode 4 Constant Reactive Power (Default)	This input is used to instruct the module to switch to <i>Reactive Mode 4 Constant Reactive Power (Default)</i>
Enable Reactive Mode 5 Power Reactive Power	This input is used to instruct the module to switch to <i>Reactive Mode 5 Power Reactive Power</i>
Enable Reactive Mode 6 VDE Voltage Reactive Power	This input is used to instruct the module to switch to <i>Reactive Mode 6 VDE Voltage Reactive Power</i>

Parameter descriptions are continued overleaf...

Function	Description
Enable Reactive Mode 7 VDE Power Reactive Power	This input is used to instruct the module to switch to <i>Reactive Mode 7 VDE Power Reactive Power</i>
Enable Reactive Mode 8 VDE Reactive Power Limited	This input is used to instruct the module to switch to <i>Reactive Mode 8 VDE Reactive Power Limited</i>
Enable Reactive Mode 9 VDE Displacement Factor $\cos \phi$	This input is used to instruct the module to switch to <i>Reactive Mode 8 VDE Displacement Factor <math>\cos \phi</math></i>
External Panel Lock	<p><b>NOTE: External control sources (i.e., Simulate Start Button) are not affected by the external panel lock input and continue to operate normally.</b></p> <p>This input is used to provide security to the installation. When the External Panel lock input is active, the module does not respond to operation of the Mode select or Start buttons. This allows the module to be placed into a specific mode (such as Auto) and then secured. The operation of the module is not affected, and the operator is still able to view the various instrumentation pages etc. (<i>Front panel configuration access is not possible while the system lock is active</i>).</p>
Fuel Tank Bund Level High	This input is used to provide protection against fuel leakage, where a level switch is fitted to the fuel tank bund. The action for this alarm is configurable under the <i>Engine Protections</i> page in the module configuration.
Generator Closed Auxiliary IEEE C37.2 - 3 Checking or Interlocking Relay	This input is used to provide feedback to allow the module to give true indication of the contactor or circuit breaker switching status. It must be connected to the generator load switching device auxiliary contact required in all parallel capable systems.
Generator Load Inhibit IEEE C37.2 - 52 AC Circuit Breaker	<p><b>NOTE: This is a required input.</b></p> <p><b>NOTE: This input only operates to control the generator-switching device if the module load switching logic is attempting to load the generator. It does not control the generator switching device when the Mains supply is on load.</b></p> <p>This input is used to prevent the module from loading the generator. If the generator is already on load, activating this input causes the module to unload the generator. Removing the input allows the generator to be loaded again.</p>
Generator Load Inhibit With Ramping	This input is used to prevent the module from loading the generator. If the generator is already on load, activating this input causes the generator to be unloaded, the power is ramped off if there is another supply available. Removing the input allows the generator to be loaded again.
Idle Running IEEE C37.2 – 18 Accelerating or Decelerating Device	This input instructs the module to give a <i>Run at Idle speed</i> command to the engine either via an output configured to <i>Idle Running</i> or by data commands when used with supported electronic engines.
Inhibit Retransfer To Mains (Single Set) IEEE 37.2 - 3 Checking or Interlocking Relay	This input prevents the load from being transferred back to the Mains supply, only in the event of the Generator Bus failure.
Inhibit Scheduled Run IEEE C37.2 – 3 Checking or Interlocking Relay	This input is used to provide a mean of disabling a scheduled run.

Parameter descriptions are continued overleaf...

Function	Description
Lamp Test	This input is used to provide a test facility for the front panel indicators fitted to the module. When the input is activated, all LEDs illuminate.
Leave AMSC Link	This input causes the module to disconnect from the AMSC link without triggering alarms in other modules. This input only works when the module is in Stop Mode with the engine stationary. If the engine is running when it is activated, it has no effect.
Load Share Inhibit	This input disables the kW & k var share control when in parallel
Low Fuel Level Switch IEEE C37.2 - 71 Liquid Level Switch	This input is used to allow feedback for low fuel level.
Main Config Select	This input is used to select the <i>Main</i> configuration when <i>Alternative Configurations</i> are enabled.
Mains Closed Auxiliary (Single Set)	This input is used to provide feedback to allow the module to give true indication of the contactor or circuit breaker switching status. It is connected to the mains load switching device auxiliary contact. Incorrect application of this signal triggers an alarm and is required for synchronising.
	<b>NOTE: This is a required input.</b>
Mains Decoupling Test Mode	<b>NOTE: This is a single-shot input. Therefore, if it is activated and a mains decoupling alarm is received, please be aware that clearing the alarm and continuing with the mains decoupling test does not rearm the system.</b>
	This input is used to enable <i>Mains Decoupling Test Mode</i> which is designed to facilitate the testing of mains decoupling functions without transitioning into parallel operation.
Mains Load Inhibit (Single Set) IEEE C37.2 - 3 Checking or Interlocking Relay	<b>NOTE: This input only operates to control the mains switching device if the module load switching logic is attempting to load the mains. It does not control the mains switching device when the generator is on load.</b>
	This input is used to prevent the module from loading the mains supply. If the mains supply is already on load activating this input causes the module to unload the mains supply. Removing the input allows the mains to be loaded again.
Mains Load Inhibit With Ramping (Single Set)	This input is used to prevent the module from loading the mains supply if a generator is currently ramping off load. If the mains supply is already on load activating this input causes the module to unload the mains supply. Removing the input allows the mains to be loaded again.
Mains Parallel Mode (Multi Set)	This input is used to configure the load-sharing module as to how it operates when in parallel. If the input is not active, the module communicates with other controllers to maintain equal share of the load between systems. If the <i>Mains Parallel Mode</i> input is active, the controller does not communicate with others but instead ramps up to the pre-configured level for Base Load or Fixed Export mode with the Mains supply.
Manual Breaker Mode	When breaker control is set to <i>Active On Input</i> , this input is used to activate the <i>Manual Breaker Control</i> .
Manual Restore Contact (Single Set)	This is only applicable when the <i>Auto Restore Inhibit</i> function is active. It is used to 'hold off' transfer back to the mains after a mains failure and keep the generator on load. Transfer back to the mains supply is held off in <i>Auto Mode</i> while the <i>Auto Restore Inhibit</i> input is present. Typically, a key switch provides this input with <i>spring return to closed</i> functionality.
Oil Pressure Switch IEEE C37.2 - 63 Pressure Switch	A digital normally open or closed oil pressure switch gives this input. It allows low oil pressure protection.

Parameter descriptions are continued overleaf...

Function	Description
Paralleling Inhibit (Single Set)	This input is used to prevent the generator from running in parallel with the Mains supply. If the input becomes active while in parallel, then the transfer is completed and paralleling ends.
Remote Start Dead Bus Synchronising (Multi Set)	<p><b>▲NOTE: For further details, refer to the section entitled <i>Advanced Options</i> elsewhere in this document.</b></p> <p>This input is used to enable a Dead Bus Synchronising start and must be used in conjunction with another starting signal such as <i>Multi Set Controller on Load</i>.</p>
Remote Start in Island Mode (Single Set)	<p>When in <i>Auto Mode</i>, the module performs the start sequence and transfer of the load to the generator. The mains breaker is left open, and the generator is to run in island mode.</p> <p>In <i>Manual Mode</i>, the load is transferred to the generator if the engine is already running, however in <i>Manual Mode</i>; this input does not generate start/stop requests of the engine.</p>
Remote Start Off Load	If this input is active, operation is like the 'Multi Set Controller on load' function except that the generator is not instructed to take the load. This function is used where an engine only run is required e.g., for exercise.
Remote Start On Load	<p>When in <i>Auto Mode</i>, the module performs the start sequence and transfer of the load to the generator.</p> <p>In Manual mode, the load is transferred to the generator if the engine is already running, however in manual mode, this input does not generate start/stop requests of the engine.</p> <p><b>▲NOTE: In Manual Mode if push buttons are enabled this input does not close the breaker.</b></p>
Remote Start On Load Demand (Multi Set)	If this input is active, the load demand start up and shut down scheme is active when two or more generators are running in parallel. Upon activation, all sets start a race for the bus. The first available set closes onto the dead bus and the others synchronise to it. Once the sets are on load, they compare load levels and redundant sets commence a shutdown sequence and return to standby until the load level is such that they are required.
Reset Electrical Trip	<p><b>▲NOTE: For further details, refer to the section entitled <i>Reset Electrical Trip</i> elsewhere in this document.</b></p> <p>This input is used to enable the <i>Reset Electrical Trip</i> function when the module is configured to do so.</p>
Reset Maintenance Alarm 1	Provides an external digital input to reset the maintenance alarm 1
Reset Maintenance Alarm 2	Provides an external digital input to reset the maintenance alarm 2
Reset Maintenance Alarm 3	Provides an external digital input to reset the maintenance alarm 3
Simulate Auto Button	<p><b>▲NOTE: If a call to start is present when AUTO MODE is entered, the starting sequence begins. Call to Start comes from several sources depending upon module type and configuration and includes (but is not limited to): Multi Set Controller input present, Mains failure, Scheduled run, Auxiliary Mains failure input present, Telemetry start signal from remote locations.</b></p> <p>This input mimic's the operation of the 'Auto' button and is used to provide a remotely located <i>Auto Mode</i> push button.</p>

Parameter descriptions are continued overleaf...

Function	Description
Simulate Lamp Test / Alarm Mute Button	This input is used to provide a test facility for the front panel indicators fitted to the module. When the input is activated all LED's illuminate. The input also serves a second function, in that it also provides a mute signal to silence the audible alarm. The input is recognised by the module as though it was the Push button on the module itself being operated.
Simulate Left Switchgear Button	Simulates the modules mains close button. See Operation Manual (057-323_G8600_ops) for further details.
Simulate Mains Available (Single Set)	This function is provided to override the module's internal monitoring function. If this input is active, the module does not respond to the state of the incoming AC mains supply.
Simulate Manual Button	This input mimics the operation of the 'Manual' button and is used to provide a remotely located Manual mode push button.
Simulate Mode Button	This input mimics the operation of the 'Mode' button and is used to toggle <i>Auto Mode</i> (Multi Set) and both Auto and Test Mode (Single Set)
Simulate Right Switchgear Button	Simulates the modules generator button. See Operation Manual (057-323_G8600_ops) for further details.
Simulate Start Button	This input mimics the operation of the 'Start' button and is used to provide a remotely located start push button.
Simulate Stop Button	This input mimics the operation of the 'Stop' button and is used to provide a remotely located stop/reset push button.
Simulate Test On Load Button (Single Set)	This input mimics the operation of the 'Test' button and is used to provide a remotely located Test on load mode push button.
Speed Lower	This is operational in Manual Mode only when the breaker is open. On systems where internal relays are used to control the governor, this input (SW1) is used to decrease the speed. SW1 is set once the breaker is closed.
Speed Raise	This is operational in Manual Mode only when the breaker is open. On systems where internal relays are used to control the governor, this input (SW1) is used to increase the speed. SW1 is set once the breaker is closed.
Start Pause IEEE C37.2 - 3 Checking or Interlocking Relay	This input is intended to be used to allow the generator start sequence to commence, but not to complete. This feature is used with air start engines for example to give a controlled start sequence. The function operates such that if the 'Start pause' input is active and an engine start is commanded, the module performs its start sequence thus: The pre-heat output (if used) is activated for the duration of the pre-heat timer. The Fuel output then is energised, and the module then enters a pause state - 'Awaiting clear to start.' If the 'start pause' signal becomes inactive currently, then the module continues its normal start sequence. The 'start pause' mode uses the 'manual crank limit' timer and if this expires during the 'Awaiting clear to start' state then a 'Fail to start' alarm is generated and the set shutdown.
Stop and Panel Lock	Combined function input that instructs the module to enter <i>STOP</i> mode and perform the <i>Panel Lock</i> function. Once the input is active, the module does not respond to operation of the mode select or start buttons. The operator is still able to view the various instrumentation pages etc. ( <i>Access to the Front Panel Editor is not possible while the Stop and Panel Lock is active</i> ).
Switch to Multi Set	Once the input is active, the module enables the DSEG8600 application for Multi Set functionality.
Switch to Single Set	Once the input is active, the module enables the DSEG8600 application for Single Set functionality.

Parameter descriptions are continued overleaf...

Editing the Configuration

Function	Description
Sync Locking Override	Once the input is active it enables sync lock without a command to close the breaker.
Telemetry Panel Lock	Once the input is active, the module does not respond to mode changes or breaker control by telemetry including Scada and Scada Suite Software (DSEG801x). The operator is still able to control and view the various instrumentation pages through the front panel buttons.
Volts Lower	This is operational in Manual Mode only when the breaker is open. On systems where internal relays are used to control the AVR, this input is used to decrease the volts.
Volts Raise	<div style="border: 1px solid black; padding: 5px; margin-bottom: 5px;">  <b>NOTE: This input has no effect when using the internal analogue system to control the AVR.</b> </div> <p>This is operational in Manual Mode only when the breaker is open. On systems where internal relays are used to control the AVR, this input is used to increase the volts.</p>
Water in Fuel	Some engines are fitted with water separators, which have a switch indicator for water detection. This input is used to provide protection against high water content in the fuel, where a switch is fitted to the fuel filter. The action for this alarm is configurable under the <i>Engine Protections</i> page in the module configuration.

### 3.4.4 VIRTUAL INPUTS

The *Virtual Inputs* section is subdivided into smaller sections. Select the required section with the mouse.

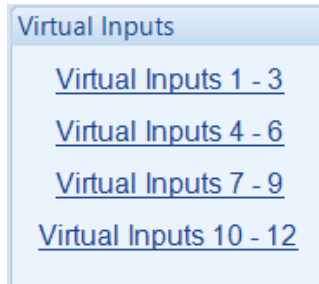

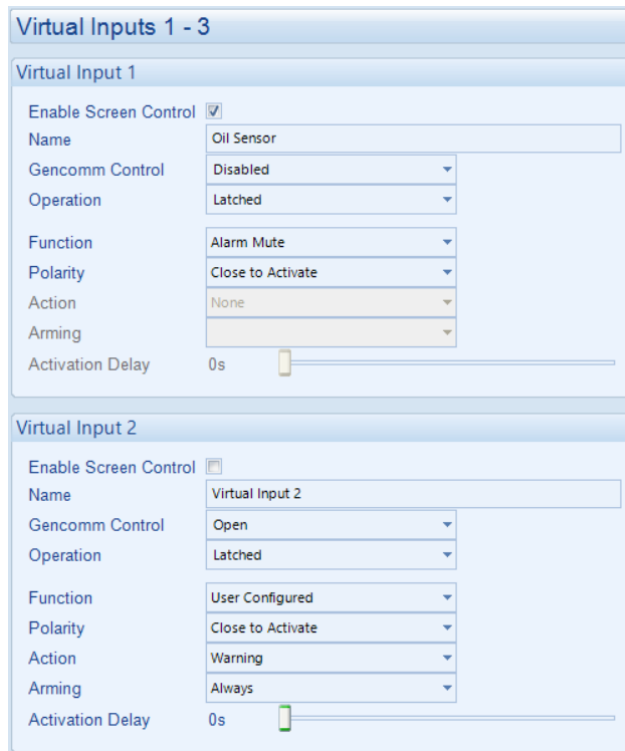

#### 3.4.4.1 VIRTUAL INPUTS



Parameter	Description
Enable Screen Control	<input type="checkbox"/> = Screen Control is disabled. <input checked="" type="checkbox"/> = Screen Control is enabled.
GenComm Control	Select the GenComm control type: <b>Disabled:</b> Not controlled by GenComm <b>Open:</b> Available for GenComm control regardless of GenComm password status <b>Protected:</b> GenComm config password must have been entered to control
Operation	Select the mode of Operation: <b>Latched</b> <b>Momentary</b>
Function	Select the input function to activate when the relevant terminal is energised. For further information see the section entitled <i>Input Functions</i> elsewhere in this document.

Parameter descriptions are continued overleaf...

Parameter	Description
Polarity	Select the Virtual Input polarity: <b>Close to Activate</b> <b>Open to Activate</b>
Action	<div style="border: 1px solid black; padding: 2px;">  <b>NOTE: For details of these, see the section entitled <i>Alarm Types</i> elsewhere in this document.</b> </div> Select the type of alarm required from the list: <b>Electrical Trip</b> <b>Indication</b> <b>Shutdown</b> <b>Warning</b>
Arming	<div style="border: 1px solid black; padding: 2px;">  <b>NOTE: For details of these, see section entitled <i>Alarm Arming</i> elsewhere in this document.</b> </div> Select when the alarm generated by the input becomes active: <b>Active from Mains Parallel</b> <b>Always</b> <b>From Safety On</b> <b>From Starting</b> <b>Never</b>
Activation Delay	This is used to give a delay on acceptance of the input. Useful for liquid level switches or to mask short term operations of the external switch device.

 **NOTE: If the virtual input is configured as momentary, any activation from the front panel is stretched by 1 second after the button is pressed. It appears to be continuously active if the button is pressed and held and is used to switch between Single Set and Multi Set. For a GenComm activation in Scada, the input is triggered when the Scada button is released, the input then remains active for 1 second. If the input is continuously triggered within 1 second of the previous trigger, the input appears to be continuously active.**

### 3.5 OUTPUTS

The *Outputs* section is subdivided into smaller sections. Select the required section with the mouse.

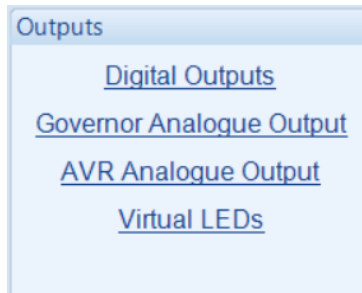

#### 3.5.1 DIGITAL OUTPUTS

These labels match the typical wiring diagram

As this example shows outputs A and B are greyed out as the engine type is selected as *Conventional Diesel*.

Relay Outputs (Supplied From Emergency Stop Input)	
Output	Source / Polarity
Output A	Fuel Relay / Energise
Output B	Start Relay / Energise
Relay Outputs (Volts Free)	
Output	Source / Polarity
Output C (N/C)	Not Used / De-Energise
Output D	Close Gen Output / Energise
Relay Outputs (DC Supply Out)	
Output	Source / Polarity
Output E	Preheat During Preheat Timer / Energise
Output F	Common Alarm / Energise
Output G	Audible Alarm / Energise
Output H	System In Auto Mode / Energise
Output I	Fuel Pump Control / Energise
Output J	Fuel Level Low Alarm / Energise
Output K	Not Used / Energise
Output L	Not Used / Energise

Parameter	Description
Source	Select the output source to control the state of the output For details of all available functions see the section entitled <i>Output Sources</i> elsewhere in this document.
Polarity	Select the digital output polarity: <b>De-Energise:</b> When the output source is true, the output deactivates. <b>Energise:</b> When the output source is true, the output activates.

### 3.5.2 GOVERNOR ANALOGUE OUTPUT

**NOTE:** To enable the Governor Analogue Output settings the *Governor Interface* setting on the *Sync Options* page must be set to *None*.

#### Output Configuration

Parameter	Description
Output Name	A free entry box to allow the user to give the Governor Analogue Output a name.

#### Output Type

Parameter	Description
Source	Select the output source to control the state of the output
Curve	Select a curve to edit or create a new curve if none is currently selected.

### 3.5.3 AVR ANALOGUE OUTPUT

**NOTE:** To enable the AVR Analogue Output settings the *AVR Output* setting on the *Sync Options* page must be set to *None*.

#### Output Configuration

Parameter	Description
Output Name	A free entry box to allow the user to give the AVR Analogue Output a name.

#### Output Type

Parameter	Description
Source	Select the output source to control the state of the output
Curve	Select a curve to edit or create a new curve if none is currently selected.

### 3.5.4 VIRTUAL LEDES

The virtual LEDs provide a configuration of 'status' items. These items are available for viewing on the module and seen in the SCADA section of the PC software, or read by third party systems (i.e., BMS or PLCs) using the Modbus protocol.

**Virtual LEDs**

LED Configuration

Show On Module	Source	Polarity	Output Description
<input type="checkbox"/> LED 1	Not Used	Lit	LED 1
<input type="checkbox"/> LED 2	Not Used	Lit	LED 2
<input type="checkbox"/> LED 3	Not Used	Lit	LED 3
<input type="checkbox"/> LED 4	Not Used	Lit	LED 4
<input type="checkbox"/> LED 5	Not Used	Lit	LED 5
<input type="checkbox"/> LED 6	Not Used	Lit	LED 6
<input type="checkbox"/> LED 7	Not Used	Lit	LED 7
<input type="checkbox"/> LED 8	Not Used	Lit	LED 8
<input type="checkbox"/> LED 9	Not Used	Lit	LED 9
<input type="checkbox"/> LED 10	Not Used	Lit	LED 10
LED 11	Not Used	Lit	
LED 12	Not Used	Lit	
LED 13	Not Used	Lit	
LED 14	Not Used	Lit	
LED 15	Not Used	Lit	
LED 16	Not Used	Lit	
LED 17	Not Used	Lit	
LED 18	Not Used	Lit	
LED 19	Not Used	Lit	
LED 20	Not Used	Lit	

Parameter	Description
Show On Module	<div style="border: 2px solid black; padding: 5px; margin-bottom: 5px;"> <b>NOTE: 10 virtual outputs are available on the module display.</b> </div> <input type="checkbox"/> = The LED is disabled on the module <input checked="" type="checkbox"/> = <b>The</b> LED is activated on Module
Source	Select the output source to control the state of the output For details of all available functions see the section entitled <i>Output Sources</i> elsewhere in this document.
Polarity	Select the digital input polarity: <b>Lit:</b> When the output source is true, the virtual LED activates <b>Unlit:</b> When the output source is true, the virtual LED deactivates.
Output Description	Enter the description of the output to appear on the module screen.

### 3.5.5 OUTPUT SOURCES

The list of output sources available for configuration of the module digital outputs.

Under the scope of IEEE 37.2, function numbers are also used to represent functions in microprocessor devices and software programs. Where the DSE output functions is represented by IEEE 37.2, the function number is listed below.

Output Source	Activates...	Is Not Active...
Not Used	The output does not change state (Unused).	

#### 3.5.5.1 ALARMS

Alarms	Output Source	Activates...	Is Not Active...
	Display Heater Fitted and ON	Active when the display heater is on.	
AMSC	AMSC Alarms Inhibited	Active when the <i>AMSC Alarms Inhibit</i> digital input function is active.	
AMSC	AMSC Data Error (Multi Set)	Indicates data error on Primary CAN bus	
AMSC	AMSC Data Error Redundant (Multi Set)	Indicates data error on Redundant Link CAN bus.	
AMSC	AMSC Failure	Indicates when the <i>AMSC Failure</i> alarm is active on both MultiSet Comms (AMSC) Links.	
AMSC	AMSC Too Few Sets	Indicates that the number of modules connected on the MultiSet Comms (AMSC) bus is less than expected and lower than the Minimum Sets Required setting.	
AMSC	Bus Sensing Failure	This alarm is active if another module in a connected segment is making the bus live and the local bus measurement is below the dead bus thresholds.	
AMSC	Invalid Modules On AMSC (Multi Set)	Active when any AMSC versions are incompatible on either MultiSet Comms (AMSC) Links.	
AMSC	Spinning Capacity Not Reached	This output is activated when the load demand system does not have the capacity running as configured.	
AMSC	Spinning Reserve Not Reached	This output is activated when the load demand system cannot achieve the configured spinning reserve.	
Bus	Bus Asymmetry High (Multi Set)	Active when the Bus Asymmetry Alarm is active.	
Bus	Bus Negative Sequence Voltage High (Multi Set)	Active when the Bus Negative Sequence Voltage Alarm is active.	
Bus	Bus Not Live (Multi Set)	This output indicates that the generator bus remains 'dead' after closing the generator load breaker.	
Bus	Bus Phase Rotation Alarm (Multi Set)	This output indicates that the module has detected a phase sequence error on the bus.	
Bus	Bus Positive Sequence Voltage Low (Multi Set)	Active when the Bus Positive Sequence Alarm is active.	

Parameter descriptions are continued overleaf...

Editing the Configuration

Alarms	Output Source	Activates...	Is Not Active....
Bus	Bus Zero Sequence Voltage High (Multi Set)	Active when the Bus Zero Sequence Alarm is active.	
Common	Common Alarm	Active when one or more alarms (of any type) are active.	The output is inactive when no alarms are present.
Common	Common Electrical Trip	Active when one or more <i>Electrical Trip</i> alarms are active.	The output is inactive when no <i>Electrical Trip</i> alarms are active.
Common	Common Shutdown	Active when one or more <i>Shutdown</i> alarms are active.	
Common	Common Warning	Active when one or more <i>Warning</i> alarms are active.	
ECU	ECU (ECM) Data Fail	Becomes active when no CANbus data is received from the ECU after the safety delay timer has expired.	Inactive when: <ul style="list-style-type: none"> <li>CANbus data is being received</li> <li>The set is at rest during the starting sequence before the safety delay timer has expired</li> </ul>
ECU	ECU (ECM) Shutdown	The engine ECU (ECM) has indicated that a Shutdown alarm is present.	Inactive when no Shutdown alarm from the ECU (ECM) is present.
ECU	ECU (ECM) Warning	The engine ECU (ECM) has indicated that a Warning alarm is present.	Inactive when no Warning alarm from the ECU (ECM) is present.
Engine	Air Flap Alarm	This output indicates that the air-flap is closed; to operate it requires an input configured as 'Air-flap closed' connected to the external air-flap switch.	
Engine	Battery High Voltage IEEE C37.2 – 59 DC Overvoltage Relay	This output indicates that a Battery Over voltage alarm has occurred.	Inactive when battery voltage is not High.
Engine	Battery Low Voltage IEEE C37.2 – 27 DC Undervoltage Relay	This output indicates that a Battery Under Voltage alarm has occurred.	Inactive when battery voltage is not Low.
Engine	Charge Alternator Failure Shutdown	Active when the charge alternator shutdown alarm is active.	
Engine	Charge Alternator Failure Warning	Active when the charge alternator warning alarm is active.	
Engine	Fail To Start IEEE C37.2 - 48 Incomplete Sequence Relay	Becomes active if the set is not seen to be running after the configurable number of start attempts.	
Engine	Fail To Stop IEEE C37.2 - 48 Incomplete Sequence Relay	If the set is still running a configurable amount of time after it has been given the stop command, the output becomes active. This configurable amount of time is the <i>Fail to Stop Timer</i> .	

Parameter descriptions are continued overleaf...

Editing the Configuration

Alarms	Output Source	Activates...	Is Not Active....
Engine	Fuel Level High Alarm	Active when the fuel level high alarm is active.	
Engine	Fuel Level High Pre-Alarm	Active when the fuel level high pre-alarm (warning) is active.	
Engine	Fuel Level Low Alarm	Active when the fuel level low alarm is active.	
Engine	Fuel Level Low Pre-Alarm	Active when the fuel level low pre-alarm (warning) is active.	
Engine	Fuel Sensor Fault	Active when the <i>Fuel Level Sensor</i> is detected as being open circuit.	
Engine	Fuel Tank Bund Level High	Active when the digital input configured for <i>Fuel Tank Bund Level High</i> is active.	
Engine	Fuel Usage Alarm IEEE C37.2 – 80 Flow Switch	Active when the <i>Fuel Usage</i> alarm becomes active.	
Engine	High Coolant Temperature Electrical Trip IEEE C37.2 – 26 Apparatus Thermal Device	Active when the <i>Coolant Temperature</i> exceeds the configured <i>High Coolant Temperature Electrical Trip</i> level.	
Engine	High Coolant Temperature Shutdown IEEE C37.2 – 26 Apparatus Thermal Device	Active when the <i>Coolant Temperature</i> exceeds the configured <i>High Coolant Temperature Shutdown</i> level.	
Engine	High Coolant Temperature Warning IEEE C37.2 – 26 Apparatus Thermal Device	Active when the <i>Coolant Temperature</i> exceeds the configured <i>High Coolant Temperature Warning</i> level.	
Engine	High Inlet Temperature Shutdown	Active when the Inlet Temperature exceeds the High Inlet Temperature Alarm setting.	
Engine	High Inlet Temperature Warning	Active when the Inlet Temperature exceeds the High Inlet Temperature Pre-Alarm setting.	
Engine	Loss of Mag Pickup Signal	Active when the controller senses the loss of signal from the magnetic pickup probe, but it has not gone open circuit.	
Engine	Low Coolant Temperature IEEE C37.2 – 26 Apparatus Thermal Device	Active when the <i>Coolant Temperature</i> falls below the <i>Low Coolant Temperature alarm</i> setting.	
Engine	Low Oil Pressure Shutdown IEEE C37.2 - 63 Pressure Switch	Active when the <i>Oil Pressure</i> falls below the <i>Low Oil Pressure Shutdown</i> setting.	Inactive when <ul style="list-style-type: none"> <li>The set is stopped</li> <li>During starting sequence before the safety delay time has expired.</li> </ul>
Engine	Low Oil Pressure Warning IEEE C37.2 - 63 Pressure Switch	Active when the <i>Oil Pressure</i> falls below the <i>Low Oil Pressure Warning</i> setting.	Inactive when <ul style="list-style-type: none"> <li>The set is stopped</li> <li>During starting sequence before the safety delay time has expired.</li> </ul>
Engine	MPU Open Circuit	This output indicates that the module has detected an open circuit failure in the Magnetic Pickup transducer circuit.	
Engine	Oil Pressure Sensor Open Circuit	Active when the <i>Oil Pressure Sensor</i> is detected as being open circuit.	

Parameter descriptions are continued overleaf...

Editing the Configuration

Alarms	Output Source	Activates...	Is Not Active....
Engine	Over Speed Shutdown IEEE C37.2 – 12 Over Speed Device	Active when the <i>Over Speed Shutdown</i> alarm is active.	
Engine	Over Speed Warning IEEE C37.2 – 12 Over Speed Device	Active when the <i>Over Speed Warning</i> alarm is active.	
Engine	Overspeed Overshoot Alarm IEEE C37.2 – 12 Over Speed Device	Active when the <i>Over Speed Overshoot</i> alarm is active.	
Engine	Overspeed Overshoot Warning IEEE C37.2 – 12 Over Speed Device	Active when the <i>Over Speed Overshoot Warning</i> alarm is active	
Engine	Under Speed Alarm	Active when any of the Underspeed Shutdown alarm is active.	
Engine	Under Speed Warning	Active when the Underspeed Warning alarm is active.	
Generator Current and Power	Arc Reduction Over Current Alarm	Active when the <i>Arc Reduction Over Current Alarm</i> is active.	
Generator Current and Power	AVR Maximum Trim Limit Reached	Indicates that the analogue AVR output has reached 100%. This indicates a fault with the control of the AVR (including connection error), incorrect setting of SW2, or that the alternator has reached its maximum capacity.	
Generator Combined	Combined Under and Over Frequency Alarm	Active when an <i>Under-Frequency</i> or <i>Over-Frequency Shutdown</i> alarm is active.	
Generator Combined	Combined Under and Over Frequency Warning	Active when an <i>Under-Frequency</i> or <i>Over-Frequency Warning</i> alarm is active.	
Generator Combined	Combined Under and Over Voltage Alarm	Active when an <i>Under-Voltage</i> or <i>Over-Voltage Shutdown</i> alarm is active.	
Generator Combined	Combined Under and Over Voltage Warning	Active when an <i>Under-Voltage</i> or <i>Over-Voltage Warning</i> alarm is active.	
Generator Current and Power	Earth Fault Trip Alarm IEEE C37.2 – 51G or 51N Generator IDMT Earth Fault Relay	Active when the <i>Earth Fault Protection Alarm</i> is active.	
Generator	Fail to Synchronise IEEE C37.2 - 48 Incomplete Sequence Relay	Becomes active if the module fails to synchronise after the <i>Fail to Sync</i> timer.	
Generator	Generator Asymmetry High IEEE C37.2 – 59	Active when the Generator Asymmetry Alarm is active.	
Generator Load Switching	Generator Failed To Close IEEE C37.2 – 52B AC Circuit Breaker Position (Contact Open When Breaker Closed)	Active when the <i>Generator Closed Auxiliary</i> input fails to become active after the <i>Close Generator Output</i> or <i>Close Generator Output Pulse</i> becomes active. The module counts the “Fail To Close Delay” timer before activating the alarm.	
Generator Load Switching	Generator Failed to Open IEEE C37.2 - 48 Incomplete Sequence Relay	This output source is intended to be used to indicate a failure of the generator contactor or breaker.	
Generator Voltage	Generator High Voltage Alarm IEEE C37.2 – 59 AC Overvoltage Relay	Active when the <i>High Voltage Shutdown</i> alarm is active.	

Parameter descriptions are continued overleaf...

Editing the Configuration

Alarms	Output Source	Activates...	Is Not Active....
Generator Voltage	Generator High Voltage Warning IEEE C37.2 – 59 AC Overvoltage Relay	Active when the <i>High Voltage Warning</i> alarm is active	
Generator Voltage	Generator Low Voltage Alarm IEEE C37.2 – 27 AC Undervoltage Relay	Active when the generator voltage falls below the <i>Low Voltage Alarm Trip</i> level.	Inactive when <ul style="list-style-type: none"> <li>• The set is stopped</li> <li>• During starting sequence before the safety delay time has expired.</li> </ul>
Generator Voltage	Generator Low Voltage Warning IEEE C37.2 – 27 AC Undervoltage Relay	Active when the generator voltage falls below the <i>Low Voltage Pre-Alarm Trip</i> level.	Inactive when <ul style="list-style-type: none"> <li>• The set is stopped</li> <li>• During starting sequence before the safety delay time has expired.</li> </ul>
Generator	Generator Negative Sequence Voltage High IEEE C37.2 – 47 Phase-Sequence Or Phase Balance Voltage Relay	Active when the Generator Negative Sequence Voltage Alarm is active.	
Generator Frequency	Generator Over Frequency Alarm IEEE C37.2 – 81 Frequency Relay	Active when the generator frequency exceeds the <i>Over Frequency Shutdown Trip</i> level.	
Generator Frequency	Generator Over Frequency Overshoot Alarm IEEE C37.2 – 81 Frequency Relay	Activates when the generator frequency exceeds the overshoot setting during the overshoot time.	
Generator Frequency	Generator Over Frequency Overshoot Warning IEEE C37.2 – 81 Frequency Relay	Activates when the generator frequency exceeds the overshoot setting warning trip level during the overshoot time.	
Generator Frequency	Generator Over Frequency Warning IEEE C37.2 – 81 Frequency Relay	Active when the generator frequency exceeds the <i>Over Frequency Warning Trip</i> level.	
Generator	Generator Phase Rotation Alarm IEEE C37.2 – 47 Phase Sequence Relay	Active when the detected generator phase sequence is different than the configured <i>Generator Phase Rotation</i> .	
Generator	Generator Positive Sequence Voltage Low IEEE C37.2 – 27 AC Undervoltage Relay	Active when the <i>Generator Positive Sequence Shutdown</i> alarm is active.	
Generator Current and Power	Generator Reverse Power IEEE C37.2 – 32 Directional Power Relay	Active when the <i>Generator Reverse Power</i> alarm is active.	
Generator Current and Power	Generator Unbalanced Current	This output is active and when the module has detected a phase generator sequence which is different from the configured generator phase rotation.	

Parameter descriptions are continued overleaf...

Editing the Configuration

Alarms	Output Source	Activates...	Is Not Active....
Generator Frequency	Generator Under Frequency Alarm	Active when any of the <i>Generator Under Frequency Shutdown</i> or <i>Electrical Trip</i> alarm are active.	
Generator Frequency	Generator Under Frequency Warning	Active when the <i>Generator Under Frequency Warning</i> alarm is active.	
Generator	Generator Zero Sequence Voltage High IEEE C37.2 – 47 Phase-Sequence or Phase Balance Voltage Relay	Active when the <i>Generator Zero Sequence Alarm</i> is active.	
Generator Current and Power	Instantaneous Overcurrent	Active when the <i>Instantaneous Overcurrent</i> alarm is active.	
Generator	Insufficient Capacity Available	Indicates that during parallel operation, it has been determined that the set(s) is (are) not capable of providing the power that they have been configured to deliver or reached the maximum generation capacity and more is required.	
Generator Current and Power	kW Overload Alarm	Active when the measured kW is above the setting of the <i>kW overload alarm</i> values. Used to give alarms on overload, control a dummy load breaker or for load shedding functionality.	
Generator Current and Power	kW Overload Warning	Active when the kW level exceeds the <i>Overload Warning Trip</i> setting for longer than the configured <i>Delay</i> time.	
Generator Frequency	Loading Frequency Not Reached	Active when the generator frequency has not reached the configured <i>Loading Frequency</i> during the starting process.	
Generator Voltage	Loading Voltage Not Reached	Active when the generator voltage has not reached the configured <i>Loading Voltage</i> during the starting process.	
Generator Current and Power	Low kW Load	Active when the kW level falls below configured <i>Low Load</i> alarm.	
Generator Load Switching	No Loading Command	This output indicates that the module is not calling for the generator load switch to be closed. When the module closes the generator load switch, this output becomes inactive.	
Generator	Out of Sync	Indicates that the <i>out of sync</i> alarm has been triggered.	
Generator	Out Of Sync Generator (Single Set)	Indicates that the Generator is not in sync with the bus after the generator switchgear has closed in parallel.	
Generator	Over Current IDMT Alarm	Active when the <i>Over Current IDMT</i> alarm is active.	
Generator	Over Current Immediate Warning	Active when the <i>Over Current Immediate Warning</i> alarm is active.	
Generator	Short Circuit Generator	This output indicates that the module has detected a short circuit on the generator output.	
Generator	Starting Alarm	This output is used to supply an external sounder with a signal that the engine is about to start. The output is active after the start delay time, during the pre-heat delay (if used) and continues until the set starts.	

Parameter descriptions are continued overleaf...

*Editing the Configuration*

<b>Alarms</b>	<b>Output Source</b>	<b>Activates...</b>	<b>Is Not Active....</b>
Mains	Combined Mains Failure (Single Set)	Active when the mains supply is out of limits OR the input for Auxiliary Mains Failure is active.	
Mains	Disable Fault Ride Through	Active when <i>Fault Ride Through</i> has been disabled and the alarm is active.	
Mains	Fault Ride Through Event	Becomes active during a <i>Fault Ride Through</i> event, the module generates a Warning alarm.	Becomes inactive when there is no <i>Fault Ride Through</i> event.
Mains	Mains Asymmetry High (Single Set) IEEE C37.2 – 59 Overvoltage Relay	Active when the Mains Asymmetry Alarm is active.	
Mains	Mains Decoupling Combined Alarm	Active when any of the <i>Mains Decoupling</i> alarms are active.	
Mains	Mains Decoupling High Frequency Stage 1,2	This output indicates that the relevant Mains decoupling high frequency alarm has been triggered.	
Mains	Mains Decoupling High Voltage Stage 1,2	This output indicates that the relevant Mains decoupling high voltage alarm has been triggered.	
Mains	Mains Decoupling Low Frequency Stage 1,2	This output indicates that the relevant Mains decoupling low frequency alarm has been triggered.	
Mains	Mains Decoupling Low Voltage Stage 1,2	This output indicates that the relevant Mains decoupling low voltage alarm has been triggered.	
Mains	Mains Decoupling QU VAR Voltage	Active when the control of voltage and reactive power (VAR) in mains decoupling protection systems is monitored.	
Mains Load Switching	Mains Failed To Close (Single Set)	This output indicates the mains breaker failed to close.	
Mains Load Switching	Mains Failed to Open (Single Set)	This output indicates the mains breaker failed to open.	
Mains	Mains Failure (Single Set) IEEE C37.2 - 81 Frequency Relay IEEE C37.2 – 27 AC Undervoltage Relay IEEE C37.2 – 59 AC Overvoltage Relay	The output indicates that one or more of the module's sources of determining mains failure is active.	
Mains	Mains High Frequency (Single Set) IEEE C37.2 -81 Frequency Relay	Active when the mains frequency exceeds the <i>High Frequency</i> setting.	
Mains	Mains High Voltage (Single Set) IEEE C37.2 – 59 AC Overvoltage Relay	Active when the mains voltage exceeds the <i>High Voltage</i> setting.	
Mains	Mains Low Frequency (Single Set) IEEE C37.2 -81 Frequency Relay	Active when the mains frequency falls below the <i>Low Frequency</i> setting.	
Mains	Mains Low Voltage (Single Set) IEEE C37.2 – 27 AC Undervoltage Relay	Active when the mains voltage falls below the <i>Low Voltage</i> setting.	

Parameter descriptions are continued overleaf...

Editing the Configuration

Alarms	Output Source	Activates...	Is Not Active....
Mains	Mains Negative Sequence Voltage High (Single Set) IEEE C37.2 – 47 Phase-Sequence or Phase Balance Voltage Relay	Active when the Mains Negative Sequence Voltage Alarm is active.	
Mains	Mains Phase Rotation Alarm (Single Set) IEEE C37.2 – 47 Phase-Sequence or Phase Balance Voltage Relay	Active when the detected mains phase sequence is different than the configured <i>Mains Phase Rotation</i> .	
Mains	Mains Positive Sequence Voltage Low (Single Set) IEEE C37.2 – 47 Phase-Sequence or Phase Balance Voltage Relay	Active when the Mains Positive Sequence Alarm is active.	
Mains	Mains ROCOF	Indicates that the ROCOF protection (mains decoupling) has triggered.	
Mains	Mains Vector Shift	Indicates that the Vector Shift protection (mains decoupling) has triggered.	
Mains	Mains Zero Sequence Voltage High (Single Set) IEEE C37.2 – 47 Phase-Sequence or Phase Balance Voltage Relay	Active when the Mains Zero Sequence Alarm is active.	
Mains	Out Of Sync Mains (Single Set)	Indicates that the Mains is not in sync with the Generator after the Mains switchgear has closed in parallel with the generator.	
Mains	Telecontrol Link Failure	Active when there is a fault with the Telecontrol Link system used to control the generator.	
Maintenance	Combined Maintenance Alarm	Active when any of the maintenance alarms are active.	
Maintenance	Maintenance Alarm 1, 2 or 3 Due	Active when the relevant maintenance alarm is due.	
Misc	3 Wire Start System Fault	Active when there is a fault with the 3 Wire Start System used to control the generator.	
Misc	Emergency Stop IEEE C37.2 – 5 Stopping Device	Active when the <i>Emergency Stop</i> input has been activated.	
Module Inputs	Analogue Input A-G (Digital)	Active when the relevant analogue input, configured as digital input, is active.	
Module Inputs	Flexible Sensor A to G Fault	Active when the relevant flexible sensor fault alarm is active. This function only works when the sensor is configured as resistive.	
Module Inputs	Flexible Sensor A to G High Alarm	Active when the relevant flexible sensor high alarm is active.	
Module Inputs	Flexible Sensor A to G High Pre-Alarm	Active when the relevant flexible sensor high pre-alarm is active.	
Module Inputs	Flexible Sensor A to G Low Alarm	Active when the relevant flexible sensor low alarm is active.	
Module Inputs	Flexible Sensor A to G Low Pre-Alarm	Active when the relevant flexible sensor low pre-alarm is active.	

3.5.5.2 CONTROL

Control	Output Source	Activates...	Is Not Active...
ECU	ECU (ECM) Power	Used to switch an external relay to power the CANbus ECU (ECM). Exact timing of this output is dependent upon the type of the engine ECU (ECM).	
ECU	ECU (ECM) Stop	Active when the DSE controller is requesting that the CANbus ECU (ECM) stops the engine.	
Generator	Air Flap Relay	Normally used to control an air flap, this output becomes active upon an Emergency Stop or Over-speed situation.	Inactive when the set has come to rest.
Generator	Check Sync IEEE C37.2 – 25 Synchronising or Synchronising Check Relay	Indicates that the internal check synchroscope has determined that the supplies are in sync.	
Generator	Coolant Cooler Control	Active by the <i>Coolant Cooler Control</i> in conjunction with the Coolant Temperature Sensor.	
Generator	Coolant Heater Control	Active by the <i>Coolant Heater Control</i> in conjunction with the Coolant Temperature Sensor.	
Generator	De-Excite Alternator (Multi Set)	Active during Dead Bus Synchronising start until the <i>Excitation Delay</i> timer expires.	
Generator	Droop Enable	Active when an input configured to <i>Droop Enable</i> is active or if <i>Droop Enable</i> has been activated in the module configuration (CANbus engine only).	
Generator	Energise To Stop	Normally used to control an <i>Energise to Stop</i> solenoid, this output becomes active when the controller wants the set to stop running.	Becomes inactive a configurable amount of time after the set has stopped. This is the <i>ETS hold time</i> .
Generator	Fan Control	Energises when the engine becomes available (up to speed and volts). This output is designed to control an external cooling fan. When the engine stops, the cooling fan remains running for the duration of the <i>Fan Overrun Delay</i> .	
Generator	Fuel Pump Control IEEE C37.2 – 71 Level Switch	Becomes active when the <i>Fuel level</i> falls below the <i>Fuel Pump Control ON</i> setting and is normally used to transfer fuel from the bulk tank to the day tank.	If the output is already active it becomes inactive when the <i>Fuel level</i> is above the <i>Fuel Pump Control OFF</i> settings.

Parameter descriptions are continued overleaf...

Editing the Configuration

Control	Output Source	Activates...	Is Not Active....
Generator	Fuel Relay	Becomes active when the controller requires the governor/fuel system to be active.	Becomes inactive whenever the set is to be stopped, including between crank attempts, upon controlled stops and upon fault shutdowns.
Generator	Generator Excite IEEE C37.2 – 31 Separate Excitation Device	Used to control the excitation of the main alternator (AC).	Becomes inactive when the set is stopped.
Generator	Idle Running	Becomes active when the controller requests that the engine runs at idle speed. As an output, this is used to give a signal to the <i>Idle Speed Input</i> on the engine speed governor (if available).	Becomes inactive when the controller requests that the engine runs at rated speed.
Generator	Load Share Inhibit	This output indicates that a digital input that has been configured as ' <i>Load Share Inhibit</i> ' is active. It indicates that Governor synchronising is disabled but has no effect on its output. Load Share and AVR (set to zero) are disabled but ECU Droop continues to function as normal.	
Generator	Louvre Control	Active when the fuel relay becomes active. Normally used to drive ventilation louvres for the generator set.	
Generator	Preheat During Preheat Timer	Becomes active when the preheat timer begins. Normally used to control the engine preheat glow-plugs.	Inactive when: <ul style="list-style-type: none"> <li>The set is stopped</li> <li>The preheat timer has expired</li> </ul>
Generator	Preheat Until End Of Cranking	Becomes active when the preheat timer begins. Normally used to control the engine preheat glow-plugs.	Inactive when: <ul style="list-style-type: none"> <li>The set is stopped</li> <li>The set has reached <i>crank disconnect</i> conditions.</li> </ul>
Generator	Preheat Until End Of Safety Timer	Becomes active when the preheat timer begins. Normally used to control the engine preheat glow-plugs.	Inactive when: <ul style="list-style-type: none"> <li>The set is stopped</li> <li>The set has reached the end of the <i>safety delay</i> timer</li> </ul>
Generator	Preheat Until End of Warming Timer	Becomes active when the preheat timer begins. Normally used to control the engine preheat glow-plugs.	Inactive when: <ul style="list-style-type: none"> <li>The set is stopped</li> <li>The set has reached the end of the <i>warming</i> timer</li> </ul>

Parameter descriptions are continued overleaf...

Editing the Configuration

Control	Output Source	Activates...	Is Not Active....
Generator	Remote Start From Digital Input	Active when any configured <i>Remote Start</i> digital input is active.	
Generator	Reset AVR to Datum	This output is intended to be used in conjunction with an electronic or motorised potentiometer, which has a 'centre pot' type input. This output is activated whenever the module needs to reset the potentiometer to its centre position.	
Generator	Reset Governor to Datum	This output is intended to be used in conjunction with an electronic or motorised potentiometer, which has a 'centre pot' type input. This output is activated whenever the module needs to reset the potentiometer to its centre position.	
Generator	Start Relay IEEE C37.2 – 54 Turning Gear Engaging Device	Active when the controller requires the cranking of the engine.	
Generator	Sync Lock Control Active	Active when Sync Lock Control on Input is active.	
Load Switching	Close Gen Output IEEE C37.2 – 52 AC Circuit Breaker	Used to control the load switching device. Whenever the module selects the generator to be on load this control source is activated.	Inactive whenever the generator is not required to be on load.
Load Switching	Close Gen Output Pulse IEEE C37.2 – 52 AC Circuit Breaker	Used to control the load switching device. Whenever the module selects the generator to be on load this control source is activated for the duration of the <i>Breaker Close Pulse</i> timer, after which it becomes inactive again.	
Load Switching	Close Mains Output (Single Set)	Used to control the load switching device. Whenever the module selects the mains to be on load this control source is activated.	The output is inactive whenever the mains is not required to be on load.
Load Switching	Close Mains Output Pulse (Single Set)	Used to control the load switching device. Whenever the module selects the mains to be on load this control source is activated for the duration of the <i>Breaker Close Pulse</i> timer, after which it becomes inactive again.	
Load Switching	Dummy Load Control (1 to 5)	Becomes active when the engine kW falls below the Dummy Load Control Trip Setting.	Inactive when the engine kW returns to above the Dummy Load Control Return setting.
Load Switching	Generator Load Inhibited	Active when the <i>Generator Load Inhibit</i> input is active	

Parameter descriptions are continued overleaf...

Editing the Configuration

Control	Output Source	Activates...	Is Not Active....
Load Switching	Interlock Override (Single Set)	Comes on just before and just after the gen-set goes into parallel enabling an output for a mechanical or electrical interlock. <i>The Interlock Override</i> deactivates after the <i>Interlock Override Off Timer</i> has expired.	
Load Switching	Load Shedding Control (1 to 5)	Becomes active when the engine kW exceeds Load Shedding Control Trip Setting.	Inactive when the engine kW returns to below the Load Shedding Control Return setting.
Load Switching	Open Gen Output IEEE C37.2 – 52 AC Circuit Breaker	Used to control the load switching device. Whenever the module selects the generator to be off load this control source is activated.	Inactive whenever the generator is required to be on load.
Load Switching	Open Gen Output Pulse IEEE C37.2 – 52 AC Circuit Breaker	Used to control the load switching device. Whenever the module selects the generator to be off load this control source is activated for the duration of the Breaker Open Pulse timer, after which it becomes inactive again.	
Load Switching	Open Mains Output (Single Set) IEEE C37.2 – 52 AC Circuit Breaker	Used to control the load switching device. Whenever the module selects the mains to be off load this control source is activated.	The output is inactive whenever the mains is required to be on load.
Load Switching	Open Mains Output Pulse (Single Set) IEEE C37.2 – 52 AC Circuit Breaker	Used to control the load switching device. Whenever the module selects the mains to be off load this control source is activated for the duration of the <i>Breaker Open Pulse</i> timer, after which it becomes inactive again.	
Misc	Audible Alarm IEEE C37.2 – 74 Alarm Relay	Use this output to activate an internal sounder, external sounder or external alarm indicator including starting alarms. Operation of the Mute pushbutton resets this output once activated.	Inactive if no alarm condition is active or if the Mute pushbutton was pressed.
Misc	Inhibit Retransfer To Mains (Single Set)	Indicates <i>Inhibit Retransfer To Mains</i> has been selected either by digital input or a tick box in <i>Config Suite</i> .	
Misc	Lamp Test	Active when the lamp test is activated by a digital input or by pressing the <i>Mute/Lamp Test</i> control button.	
Power Control	1 Constant Power Mode (Default)	Active when the <i>Power Mode 1 Constant Power (Default)</i> is selected.	
Power Control	2 Frequency-Power Mode	Active when the <i>Power Mode 2 Frequency Power</i> is selected.	
Power Control	3 Voltage-Power Mode	Active when the <i>Power Mode 3 Voltage Power</i> is selected.	

Parameter descriptions are continued overleaf...

*Editing the Configuration*

<b>Control</b>	<b>Output Source</b>	<b>Activates...</b>	<b>Is Not Active....</b>
Power Control	4 VDE Frequency Power Mode	Active when the <i>Power Mode 4 VDE Frequency Power</i> is selected.	
Voltage and Reactive Power Control	1 Constant Power Factor Mode	Active when the <i>Reactive Mode 1 Constant Power Factor</i> is selected.	
Voltage and Reactive Power Control	2 Voltage-Reactive Power Mode	Active when the <i>Reactive Mode 2 Voltage Reactive Power</i> is selected.	
Voltage and Reactive Power Control	3 Power-Power Factor Mode	Active when the <i>Reactive Mode 3 Power Factor</i> is selected.	
Voltage and Reactive Power Control	4 Constant Reactive Power Mode (Default)	Active when the <i>Reactive Mode 4 Constant Reactive Power (Default)</i> is selected.	
Voltage and Reactive Power Control	5 Power Reactive Power Mode	Active when the <i>Reactive Mode 5 Power Reactive Power</i> is selected.	
Voltage and Reactive Power Control	6 VDE Voltage Reactive Power Mode	Active when the <i>Reactive Mode 6 VDE Voltage Reactive Power</i> is selected.	
Voltage and Reactive Power Control	7 VDE Power Reactive Power Mode	Active when the <i>Reactive Mode 7 VDE Power Reactive Power</i> is selected.	
Voltage and Reactive Power Control	8 VDE Reactive Power Limited Mode	Active when the <i>Reactive Mode 8 VDE Reactive Power Limited</i> is selected.	
Voltage and Reactive Power Control	9 VDE Displacement Factor $\cos \phi$ Mode	Active when the <i>Reactive Mode 9 VDE Displacement Factor <math>\cos \phi</math></i> is selected.	

3.5.5.3 STATUS

Status	Output Source	Activates...	Is Not Active...
Aftertreatment	DEF Level Low	Active when <i>DEF Level Low</i> CANbus alarm is active.	
Aftertreatment	SCR Inducement	Active when <i>SCR Inducement CAN Alarm</i> is active.	
AMSC	AMSC Link Disabled	Active when linked to a Digital Input.	
Bus	Bus Live (Multi Set)	This output indicates that a voltage has been detected on the bus. Once the voltage on the bus is detected above the "Dead bus relay setting," it is no longer considered a 'dead-bus,' and the generator needs to synchronise to close onto the bus.	
Status Communications	Remote Start Over AMSC (Multi Set)	Indicates that the controller has received a <i>Remote Start On Load</i> signal via the AMSC link.	
Electrical Trip	Electrical Trip Reset	Active when the electrical trip has been reset.	Inactive on the next electrical trip alarm or when the generator is at rest.
Electrical Trip	Electrical Trip Reset Count Exhausted	Active when the maximum number of resets within specified period has been reached.	Inactive when the generator is at rest.
Electrical Trip	Electrical Trip Stop Inhibited	Becomes active when the generator has been on load, there is an active electrical trip alarm and inhibit engine stop has been enabled.	
Electrical Trip	Waiting for Electrical Trip Reset	Active when an electrical trip alarm is active and waiting for it to be reset.	Inactive when the electrical trip alarm has been reset or when the generator is at rest.
Engine	AVR Data Fail	Active when the AVR Data Fail alarm is active, indicating communication failure with the CAN AVR.	
Engine	AVR Fault	Active when the AVR Fault alarm is active, indicating an alarm detection on the CAN AVR.	
Engine	Water In Fuel	Active when the digital input function <i>Water In Fuel</i> is active.	
Generator	All Available Sets Are On The Bus (Multi Set)	This output indicates that all the available sets in the Multiset load sharing system are closed onto the generator bus. This output is used to close an external breaker to allow the generator bus to power the load. 'Available sets' are sets in <i>Auto Mode</i> with no alarms present. So, sets not in <i>Auto Mode</i> or sets that have alarms present are not considered to be 'available sets.'	
Generator	Generator at Rest	This output indicates that the generator is not running, and no alarms are active.	

Parameter descriptions are continued overleaf...

Editing the Configuration

Status	Output Source	Activates...	Is Not Active....
Generator	Generator Available	Active when the generator is available to take load.	Inactive when <ul style="list-style-type: none"> <li>• <i>Loading voltage and loading frequency</i> have not been reached</li> <li>• After <i>electrical trip</i> alarm</li> </ul> During the starting sequence before the end of the warming timer.
Generator	Generator Stopping	This output source indicates that the engine has been instructed to stop but has not yet come to rest. Once the engine comes to a standstill this output becomes inactive.	
Generator	Low Load	Indicates that the stopping sequence is beginning due to low load levels. ( <i>Load Demand Scheme</i> ).	
Generator	Panel locked	Active when any panel locked sources are active.	
Generator	Starting Alarms Armed	This output indicates that the starting alarms are now enabled. It is used to control external logic circuitry. Starting alarms are armed as soon as the module commences starting of the engine and remain armed until the engine is at rest.	
Generator	Working Adjusted Nominal Volts (Multi Set)	Active when the nominal voltage is different than the configured nominal voltage. Indicates that the nominal voltage was changed through the module FPE and set to a different voltage than the configured nominal voltage.	
Load Switching	Gen And Mains In Parallel (Single Set)	This output is active whenever the generator and mains are in parallel.	This output is not active whenever the generator and mains are not in parallel.
Load Switching	Generator Closed Aux	Active when the <i>Generator Closed Auxiliary</i> input is active	
Load Switching	Genset Closed to Power Bus	Active when the generator breaker is closed onto the Power Bus.	
Load Switching	Mains Closed Aux (Single Set)	Active when the <i>Mains Closed Auxiliary</i> input is active.	
Mains	Clear Mains Decoupling	Active when the <i>Clear Mains Decoupling Alarms</i> digital input is active.	
Mains	Critical Frequency Rate Limit Active	Active when the critical frequency is limiting the power ramp rate.	
Mains	Grid monitoring time active	Active during the time in which the grid monitoring system is monitoring and analysing the performance of the electrical grid.	
Mains	Mains Decoupling QU Alarm Disable Input	Active when the Mains Decoupling QU Alarm Disable Input is activated..	
Mains	Mains Decoupling Test Mode Active	Active when the <i>Mains Decoupling Test Mode</i> is active.	
Mains	Mains Decoupling Test Mode input	Active when the <i>Mains Decoupling Test Mode input</i> is active.	
Module Inputs	Alarm Mute	Active when the alarm mute digital input is active.	
Module Inputs	Alarm Reset	Active when the alarm reset digital input is active.	

Parameter descriptions are continued overleaf...

*Editing the Configuration*

Status	Output Source	Activates...	Is Not Active....
Module Inputs	Auto Restore Inhibit (Single Set) IEEE C37.2 - 3 Checking or Interlocking Relay	Active when the Auto Restore Inhibit function is active.	
Module Inputs	Auto Run Inhibited	Active when the <i>Auto Run Inhibit</i> function is active.	
Module Inputs	Auto Start Inhibit	Active when the <i>Auto-Start Inhibit</i> function is active.	
Module Inputs	Auxiliary Mains Failure (Single Set)	Active when the Auxiliary Mains Fail input function is active.	
Module Inputs	DC Power On	Active when DC power is supplied to the module.	
Module Inputs	Digital Input A, B, C, D, E, F, G H & I	Active when the relevant digital input is active.	
Module Inputs	Duty Select (Multi Set)	Indicates that a digital input configured to <i>Duty Select</i> is active.	
Module Inputs	EJP1 / EJP2	Active when an input configured for <i>EJP1</i> or <i>EJP2</i> is active.	
Module Inputs	Force Low Master Priority	Active when the priority of a specific generator in a multi-generator setup has been lowered.	
Module Inputs	Frequency Droop Input (Multi Set)	Active when the <i>Frequency Droop Enable</i> input has been activated.	
Module Inputs	Inhibit Scheduled Run	Active when the Inhibit Scheduled run input is active.	
Module Inputs	Mains Load Inhibited (Single Set)	Active when the <i>Mains Load Inhibit</i> digital input is active.	
Module Inputs	Mains Parallel Mode Input (Multi Set)	Active when the Mains Parallel Mode digital input becomes active.	
Module Inputs	Manual Restore Contact (Single Set)	Active when the manual restore contact input is active.	
Module Inputs	Mute / Lamp Test Button Pressed	This output indicates that the alarm mute / Lamp test push button is being operated. Once the button is released, the output becomes inactive.	
Module Inputs	Panel Locked By Digital Input	Active when the panel is locked by Digital Input.	
Module Inputs	Parallel Inhibit (Single Set)	Active when the <i>Parallel Inhibit</i> digital input is active.	
Module Inputs	Remote Start In Island Mode (Single Set)	This output indicates that a digital input that has been configured as ' <i>Remote Start In Island mode</i> ' is active. This output could be used to pass the start signal on to elsewhere in the control system.	
Module Inputs	Remote Start Off Load	Active when the <i>Remote Start Off Load</i> input is active.	
Module Inputs	Remote Start On Load	Active when the <i>Remote Start On Load</i> input is active.	
Module Inputs	Remote Start On Load Demand (Multi Set)	Indicates that the module's input is active for <i>Remote Start On Load Demand</i> (Multi-Set). Also indicates that the controller has received a <i>Remote Start On Load</i> signal via the AMSC link.	
Module Inputs	Reset Maintenance 1, 2 or 3	Active when the relevant <i>Maintenance Alarm Reset</i> is active.	
Module Inputs	Simulate Auto Button	Active when the Simulate Auto Button digital input is active.	
Module Inputs	Simulate Left Switchgear Button	Active when the Simulate Left Switchgear Button digital input is active	

Parameter descriptions are continued overleaf...

Editing the Configuration

Status	Output Source	Activates...	Is Not Active....
Module Inputs	Simulate Mains Available	Active when the <i>Simulate Mains Available</i> digital input is active.	
Module Inputs	Simulate Manual Button	Active when the Simulate Manual Button digital input is active.	
Module Inputs	Simulate Mode Button	Active when the Simulate Mode Button digital input is active.	
Module Inputs	Simulate Right Switchgear Button	Active when the Simulate Right Switchgear Button digital input is active.	
Module Inputs	Simulate Start Button	Active when a digital input configured to Simulate Start Button is active.	
Module Inputs	Simulate Stop Button	Active when the Simulate Stop Button digital input is active.	
Module Inputs	Simulate Test On Load Button (Single Set)	Active when the <i>Simulate Test On Load Button</i> digital input is active.	
Module Inputs	Stop And Panel Lock	Active when the Stop And Panel Lock digital input is active.	
Module Inputs	Stop Button Pressed	This output indicates that the stop pushbutton is being operated. Once the button is released, the output becomes inactive.	
Module Inputs	Sync Lock Input	Active when Sync Lock On Input is enabled.	
Module Inputs	Telemetry Panel Lock	Active when the Telemetry Panel Lock digital input is active.	
Module Inputs	Voltage Droop Input (Multi Set)	Active when the Voltage Droop Enable input has been activated.	
Operation	3 Wire Start Integrity	Active when the 3 Wire Start Integrity system is active and monitoring the reliability of the start signal circuit for generators.	
Operation	Alternative Config 1-5 Selected	Active when the alternative configuration is selected.	
Operation	Arc Reduction Over current Protection Active	Active when an overcurrent fault is detected.	Inactive when an overcurrent fault has been cleared.
Operation	Arm Safety On Alarms	Becomes active at the end of the <i>safety delay</i> timer whereupon all alarms configured to 'From Safety On' become active.	Inactive when: When the set is at rest In the starting sequence before the Safety Delay timer has expired.
Operation	Calling for Scheduled Run	Active during a Scheduled Run request from the inbuilt Scheduler.	
Operation	Closed To Generator State (Multi Set)	Active when the status of the generator breaker is closed.	
Operation	Closed To Mains State (Single Set)	Active when the status of the mains breaker is closed.	
Operation	Cooling Down	Active when the Cooling timer is in progress.	
Operation	Data Logging Active	Active when data is being logged.	Inactive when: Data logging is disabled The engine is at rest and the option <i>Only Log When Engine Is Running</i> is enabled The internal memory of the module becomes full, and the option <i>Keep Oldest Data</i> is enabled.

Parameter descriptions are continued overleaf...

Editing the Configuration

Status	Output Source	Activates...	Is Not Active....
Operation	Dead Bus Synchronise Enabled (Multi Set)	Active when Dead Bus Synchronising is enabled.	
Operation	Dead Bus Synchronise In Progress (Multi Set)	Active when the set is running dead bus synchronising.	
Operation	Frequency Droop Enabled (Multi Set)	Active when the <i>Frequency Droop</i> has been activated.	
Operation	Line Power	Active when the generator is connected to and receiving power from the utility grid.	
Operation	Load Demand Delay Active (Multi Set)	Indicates that the set has closed onto the bus and that the <i>Load Demand Delay</i> is in progress. When this has expired, the <i>Load Demand Scheme</i> is activated.	
Operation	Main Config Selected	Active when the main configuration is active.	
Operation	Multi Set Application Selected	Active when the module is running the <i>Multi Set</i> application.	
Operation	Protections Disabled	Active when protections are disabled (ticked) in the configuration. If it is set as <i>On Input</i> it needs the input active as well.	
Operation	Return Delay In Progress	This output source is active to indicate that the return timer is running.	
Operation	Scheduled Auto Start Inhibit	Active during a <i>Scheduled Auto Start Inhibit</i> request from the inbuilt <i>Scheduler</i> .	
Operation	Shutdown Blocked	Becomes active when protections are disabled and one of the active trip or shutdown alarms are active.	
Operation	Single Set Application Selected	Active when the Single Set Application is selected.	
Operation	Start Delay in Progress	This output source is active to indicate that the module's internal start delay timer is running. Once this timer expires the module initiates its start sequence.	
Operation	Start Paused	Active when the Start Pause digital input is active.	
Operation	Synching Enabled	This output indicates that the synchronisation feature has been enabled.	
Operation	System Healthy	This output indicates that the module is in <i>Auto Mode</i> and there are no alarms present.	
Operation	System in Auto Mode	Active when <i>Auto Mode</i> is selected.	
Operation	System in Manual Mode	Active when Manual mode is selected.	
Operation	System in Stop Mode	Active when Stop mode is selected.	
Operation	System In Test Mode (Single Set)	Active when Test On Load mode is selected.	
Operation	Voltage Droop Enabled (Multi Set)	Active when the Voltage Droop has been activated.	
Operation	Waiting For Generator	This output indicates that the engine has been instructed to start but has not yet become available. Once the generator becomes available this output becomes in-active. (Available = Generator Frequency and Voltage levels are above the ' <i>Loading</i> ' levels set in the configuration).	

Parameter descriptions are continued overleaf...

Editing the Configuration

Status	Output Source	Activates...	Is Not Active....
Operation	Waiting For Manual Restore (Single Set)	Becomes active when the generator is on load and the mains supply is healthy, but an input configured to <i>Auto Restore Inhibit</i> is active. This is used to signal to an operator that action is required before the set transfers back to the mains supply.	
Regeneration	DPF Auto Regen Inhibit Request	Active when the <i>DPF Auto Regen Inhibit Request</i> is active.	
Regeneration	DPF Forced Regeneration Requested	Active when the <i>DPF Force Regeneration</i> is active.	
Regeneration	DPF Non-Mission State	Active when the <i>DPF Non-Mission State</i> is active.	
Regeneration	DPF Regeneration In Progress	Active when the <i>DPF Regeneration</i> is in progress.	
Regeneration	DPF Regeneration Interlock Active	Active when the <i>DPF Regeneration Interlock</i> is active.	
Regeneration	DPTC Filter	Active when the diesel particulate filter CANbus alarm is active.	
Regeneration	HEST Active	Active when the High Exhaust System Temperature CANbus alarm is active..	
Telemetry	Combined Remote Start Request	Indicates that a Remote Start request is active.	
Telemetry	Panel Locked By Telemetry	Active when the panel is locked by Telemetry.	
Telemetry	Telemetry Active	Active when the communication port is live and for a short time after transmission stops. Used as a relay or LED source.	
Telemetry	Telemetry Active RS485 1 & 2	Active when the RS485 communication ports are live and for a short time after transmission stops. Used as a relay or LED source.	
Telemetry	Telemetry Data Active RS485 1 & 2	Active when data is being transmitted on RS485 ports 1 & 2. This output changes state continuously (flash) upon data transfer. Normally used as an LED source rather than a relay source as the signal flashes repeatedly. For a similar source more suited to drive a relay, see Telemetry Active.	
Telemetry	Telemetry Data Active	Active when data is being transmitted. This output changes state continuously (flash) upon data transfer. Normally used as an LED source rather than a relay source as the signal flashes repeatedly.	
Telemetry	Telemetry Start in <i>Auto Mode</i>	Active when a Multi Set Controller Request is sent over by communication.	
Virtual Input	Virtual Input 1-12	Active when the Virtual Input 1 to 12 has been activated	

### 3.6 TIMERS

Many timers are associated with alarms. Where this occurs, the timer for the alarm is located on the same page as the alarm setting. Timers not associated with an alarm are located on the *Timers* page. The *Timers* page is subdivided into smaller sections. Select the required section with the mouse.

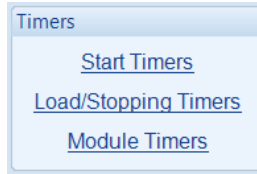

#### 3.6.1 START TIMERS

##### Start Delay

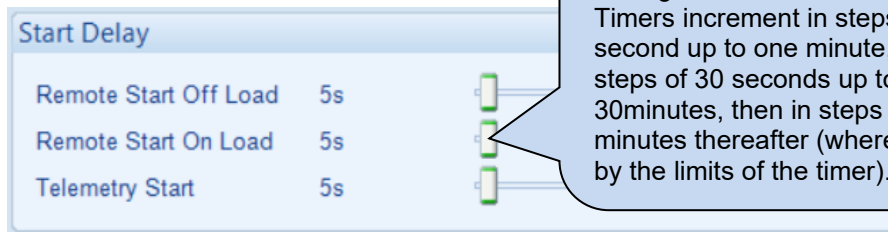

Click and drag to change the setting.  
Timers increment in steps of 1 second up to one minute, then in steps of 30 seconds up to 30minutes, then in steps of 30 minutes thereafter (where allowed by the limits of the timer).

Timer	Description
Remote Start Off Load	The amount of time delay before starting in <i>Auto Mode</i> . This timer is activated upon the <i>Multi Set or Single Set Controller Off Load</i> command being issued. Typically, this timer is applied to prevent starting upon fleeting start signals.
Remote Start On Load	The amount of time delay before starting in <i>Auto Mode</i> . This timer is activated upon the <i>Multi Set or Single Set Controller On Load</i> command being issued. Typically, this timer is applied to prevent starting upon fleeting start signals.
Telemetry Start	The amount of time delay before starting in <i>Auto Mode</i> . This timer is activated upon a command being received from a Modbus client. Typically, this timer is applied to prevent starting upon fleeting start signals.

##### Start Delay (Single Set)

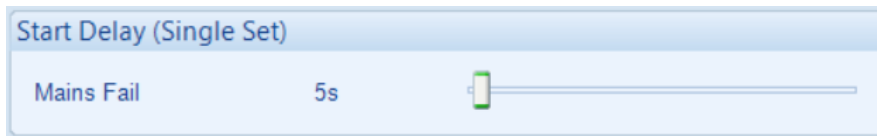

Timer	Description
Mains Fail	The amount of time delay before starting in <i>Auto Mode</i> . This timer is activated upon a mains failure detection.

**Start Delay (Group Controller)**

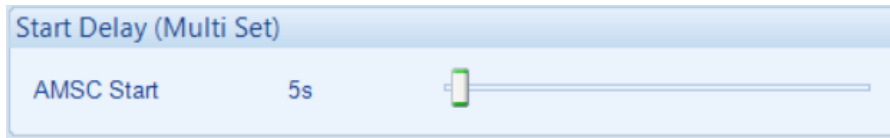

Timer	Description
AMSC Start	The amount of time delay before starting in <i>Auto Mode</i> . This timer is activated upon to delay the AMSC client request on the Group controller.

**Start Timers**

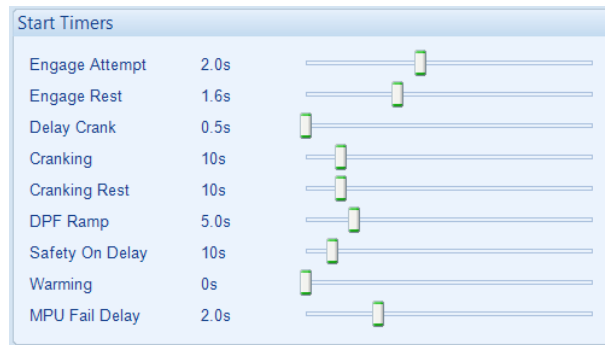

Timer	Description
Engage Attempt	<p><b>NOTE: Only available if using magnetic pick-up and multiple engage attempts.</b></p> <p>The amount of time the module attempts to engage the starter motor during each engage attempt. If the Magnetic Pick-up is not detecting movement of the flywheel when this timer expires, the engage attempt terminates. When the engage fails consecutively for the configured number of <i>Engage Attempts</i>, the <i>Fail to Engage</i> alarm is activated.</p>
Engage Rest	<p><b>NOTE: Only available if using magnetic pick-up and multiple engage attempts.</b></p> <p>The amount of time the module waits between attempts to engage the starter.</p>
Delay Crank	The amount of time delay between the fuel relay and the crank relay energising. This is typically used to allow fuel systems to prime.
Cranking	The amount of time for each crank attempt.
Crank Rest	The amount of time between multiple crank attempts.
DPF Ramp	The amount of time that the engine takes to run up to rated speed after running at its DPF speed.
Safety On Delay	The amount of time at start-up that the controller ignores oil pressure and engine under speed and other delayed alarms. This is used to allow the engine to run up to speed before protections are activated.
Warming	The amount of time the engine runs before being allowed to take load. This is used to warm the engine to prevent excessive wear.
MPU Fail Delay	<p><b>NOTE: Only available if using Magnetic pick-up.</b></p> <p>The amount of time during which the module must receive a speed signal once cranking has commenced. If no signal is present, the engine is stopped, and a <i>Loss of Speed Sensing</i> alarm given.</p>

**Start Timers (Single Set)**

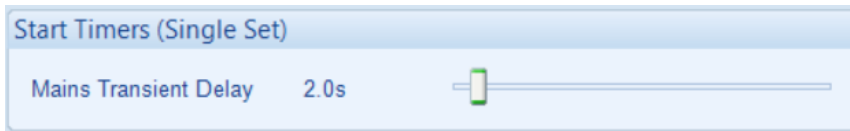

Timer	Description
Mains Transient Delay	Used to give a delay between sensing mains failure and acting upon it. This is used to prevent dropouts of the mains load switch and operation of the system due to mains supply transient conditions.

**3.6.2 LOAD / STOPPING TIMERS**

**Load Timers**

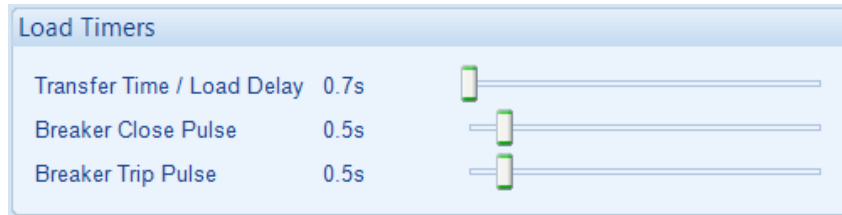

Timer	Description
Transfer Time	The time between one load switch opening and the other closing when a break transfer is required.
Breaker Close Pulse	The amount of time that <i>Breaker Close Pulse</i> signal is present when the request to close the load switch is given.
Breaker Trip Pulse	The amount of time that <i>Breaker Open Pulse</i> signal is present when the request to open the load switch is given.

**Load Timers (Single Set)**



Timer	Description
Parallel Run Time	This timer dictates how long the generator runs in parallel with the mains supply before ramping down.

**Return Delay Timers**

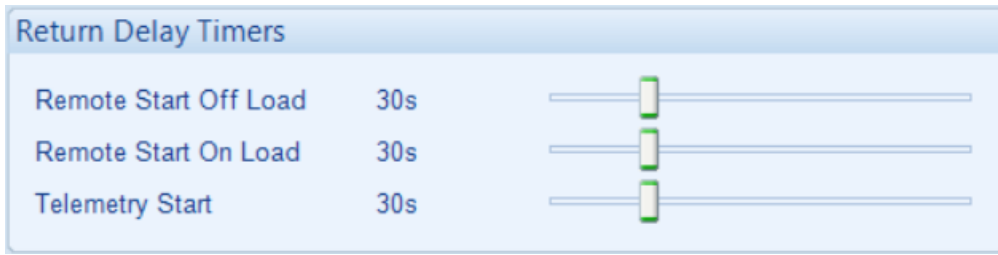

Timer	Description
Remote Start Off Load	A delay, used in <i>Auto Mode</i> only, that allows for short term removal of the Remote Start off Load request to stop the set before action is taken. This is usually used to ensure the set remains on load before accepting that the start request has been removed.
Remote Start On Load	A delay, used in <i>Auto Mode</i> only, that allows for short term removal of the Remote Start on Load request to stop the set before action is taken. This is usually used to ensure the set remains on load before accepting that the start request has been removed.
Telemetry Start	A delay, used in <i>Auto Mode</i> only, that allows for short term removal of the GenComm request to stop the set before action is taken. This is usually used to ensure the set remains on load before accepting that the start request has been removed.

**Return Delay Timers (Multi Set)**

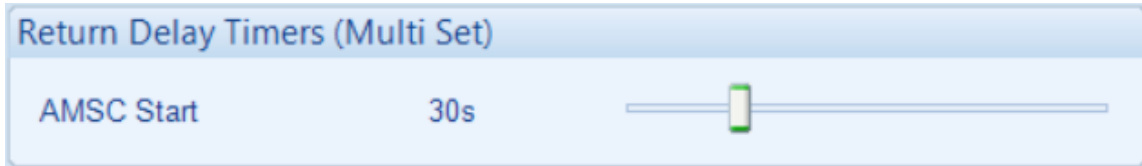

Timer	Description
AMSC Start	A delay, used in <i>Auto Mode</i> only, that allows for short term removal of the AMSC client request to stop the generator before any action is taken. This is usually used to ensure the generators in the load demand scheme are on load before others accept that their start request has been removed.

**Return Delay Timers (Single Set)**

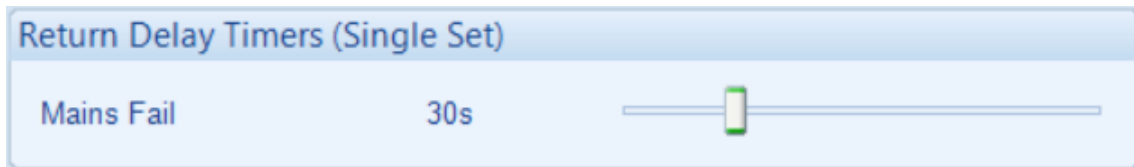

Timer	Description
Mains Fail	A delay, used in <i>Auto Mode</i> only, that allows for short term removal of the request to stop (Mains Return) the set before action is taken. This is usually used to ensure the set remains on load before accepting that the start request has been removed.

**Stopping Timers**



Timer	Description
Cooling	The amount of time that the set is made to run OFF LOAD before being stopped. This is to allow the set to cool down and is particularly important for engines with turbo chargers.
Cooling at Idle	The amount of time that the set is made to run OFF LOAD and at Idle Speed before being stopped.
ETS Solenoid Hold	The amount of time the <i>Energise to stop</i> solenoid is kept energised after the engine has come to rest. This is used to ensure the set has fully stopped before removal of the stop solenoid control signal.
Fail to stop Delay	If the set is called to stop and is still running after the <i>fail to stop</i> delay, a <i>Fail to Stop</i> alarm is generated.

### 3.6.3 MODULE TIMERS

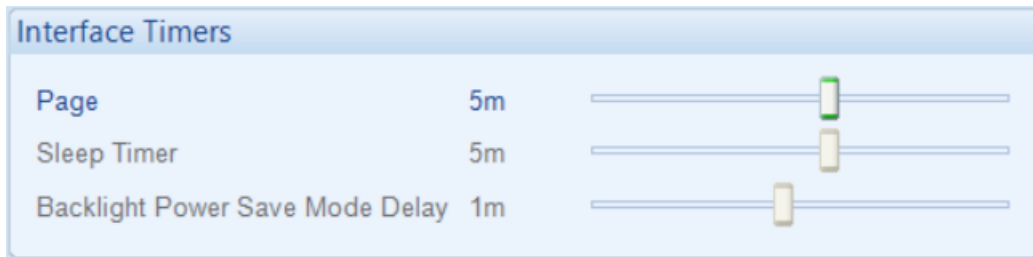

Timer	Description
Page	If the module buttons are not pressed for the duration of the <i>LCD Page Timer</i> it reverts to show the <i>Status</i> page.
Sleep Timer	If the module is left in Stop Mode and is at rest with no communication for the duration of the <i>Sleep Timer</i> , it goes into sleep mode to save power.
Backlight Power Save Mode Delay	If the module is left unattended for the duration, the Backlight goes into Power Save Mode.

### 3.7 GENERATOR

The *Generator* section is subdivided into smaller sections.  
Select the required section with the mouse



### 3.7.1 GENERATOR OPTIONS

#### Generator Options

Select your AC system. A schematic is shown below with connection details from the alternator to the module.

Click to enable or disable the feature. The relevant values below appear *greyed out* when the alarm is disabled.

Parameter	Description
Alternator Fitted	<input type="checkbox"/> = There is no alternator in the system, it is an <i>engine only</i> application <input checked="" type="checkbox"/> = An alternator is fitted to the engine; it is a generator application.
Poles	The number of poles on the alternator.
AC System	Select the AC topology of the generator from the following list: <b>2 Phase, 3 Wire L1 - L2</b> <b>2 Phase, 3 Wire L1 - L3</b> <b>3 Phase, 3 Wire</b> <b>3 Phase, 3 Wire NVD</b> <b>3 Phase, 4 Wire</b> <b>3 Phase, 4 Wire Delta L1 - N - L2</b> <b>3 Phase, 4 Wire Delta L1 - N - L3</b> <b>3 Phase, 4 Wire Delta L2 - N - L3</b> <b>Single Phase, 2 Wire</b> <b>Single Phase, 3 Wire L1 - L2</b> <b>Single Phase, 3 Wire L1 - L3</b>
VT Fitted	<input type="checkbox"/> = The voltage sensing to the controller is direct from the alternator <input checked="" type="checkbox"/> = The voltage sensing to the controller is via Voltage Transformers (VTs or PTs)  This is used to step down the generated voltage to be within the controller voltage specifications. By entering the <i>Primary</i> and <i>Secondary</i> voltages of the transformer, the controller displays the <i>Primary</i> voltage rather than the actual measured voltage.  This is typically used to interface the DSE module to high voltage systems (i.e., 11kV).

**Generator Phase Rotation**

Parameter	Description
Generator Phase Rotation IEEE C37.2 – 47 Phase Sequence Relay	<input type="checkbox"/> = Generator phase rotation is not checked. <input checked="" type="checkbox"/> = An electrical trip alarm is generated when the measured phase rotation is not as configured.

**Breaker Control**

Parameter	Description
Enable Breaker Alarms	<input type="checkbox"/> = Alarm is disabled <input checked="" type="checkbox"/> = The <i>Generator Breaker Alarms</i> are enabled.
Fail To Open Delay	When the <i>Open Generator</i> output is activated, if the configured <i>Generator Closed Auxiliary</i> digital input does not become active within the <i>Generator Fail To Open Delay</i> timer, the alarm is activated.
Fail To Close Delay	When the <i>Close Generator</i> output is activated, if the configured <i>Generator Closed Auxiliary</i> digital input does not become active within the <i>Generator Fail To Close Delay</i> timer, the alarm is activated.

### 3.7.2 GENERATOR RATING

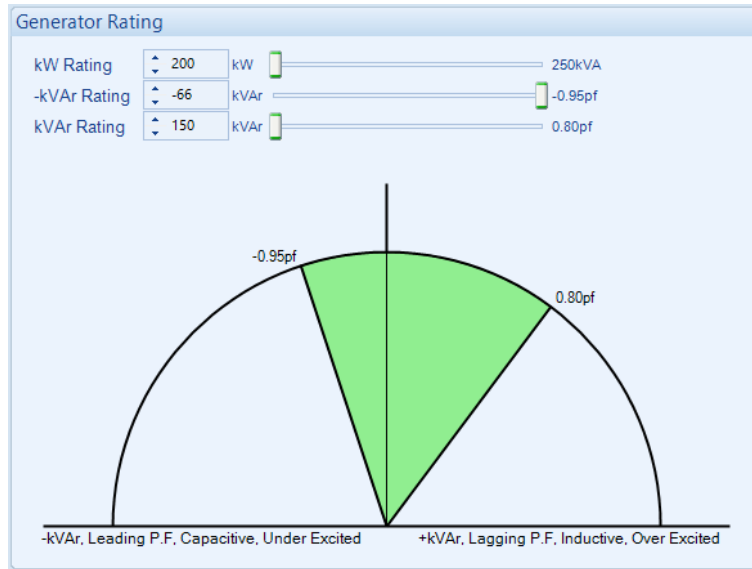

Parameter	Description
kW Rating	The kW rating of the generator is the maximum power available to load share functions. This is used for all <i>Generator Power</i> functions in addition to the rating in which the kW load sharing calculations are based on.
kvar Rating	<p>The positive kvar rating of the generator. This is used for all <i>AVR</i> functions in addition to the rating in which the kvar load sharing calculations are based on. To calculate the kvar rating of a genset:</p> <ul style="list-style-type: none"> <li>Most generators are rated for a lagging power factor (kW / kVA) of 0.8</li> <li>From Pythagoras:                     <math display="block">\cos \Phi = \frac{\text{kW}}{\text{kVA}}</math> <math display="block">\cos \Phi = 0.8</math> <math display="block">\Phi = \cos^{-1} 0.8 = 36.87^\circ</math> </li> <li>From this, the kvar rating of the typical 0.8 pf rated generator is:                     <math display="block">\tan \Phi = \frac{\text{kvar}}{\text{kW}}</math> <math display="block">\text{kvar} = \tan 36.87^\circ \times \text{kW}</math> <math display="block">\text{kvar} = 0.75 \times \text{kW}</math> </li> <li>Or to simplify this, the kvar rating of a 0.8 pf rated generator is <math>\frac{3}{4}</math> of the kW rating (kvar rating = 75% of kW rating).</li> </ul>
-kvar Rating	<p>The negative kvar rating of the generator. This is only used to limit the magnitude of negative kvar which the generator produces when in parallel with the mains.in addition to the rating in which the kvar load sharing calculations are based on. To calculate the kvar rating of a genset:</p> <ul style="list-style-type: none"> <li>Most generators are rated for a leading power factor of 0.95</li> <li>From Pythagoras:                     <math display="block">\cos \Phi = \frac{\text{kW}}{\text{kVA}}</math> <math display="block">\cos \Phi = 0.95</math> <math display="block">\Phi = \cos^{-1} 0.95 = 18.20^\circ</math> </li> <li>From this, the kvar rating of the typical 0.95 pf rated generator is:                     <math display="block">\tan \Phi = \frac{\text{kvar}}{\text{kW}}</math> <math display="block">\text{kvar} = \tan 18.20^\circ \times \text{kW}</math> <math display="block">\text{kvar} = 0.33 \times \text{kW}</math> </li> <li>Or to simplify this, the kvar rating of a 0.95 pf rated generator is <math>\frac{1}{3}</math> of the kW rating (-kvar rating = 33% of kW rating).</li> </ul>

### 3.7.3 GENERATOR DE-RATE

**NOTE:** When the *Power De-Rate* or the *Reactive Power De-Rate* are enabled, the DSE module shows the kW De-Rate and kvar De-Rate pages on its LCD display.

**NOTE:** The *Power De-Rate* and the *Reactive Power De-Rate* are adjusted from the *PLC Editor*, through the *GenComm Override* functionality, or from the Scada configuration section, or through Modbus.  
For more information, refer to the sections *PLC* and *De-Rate* elsewhere in this document.

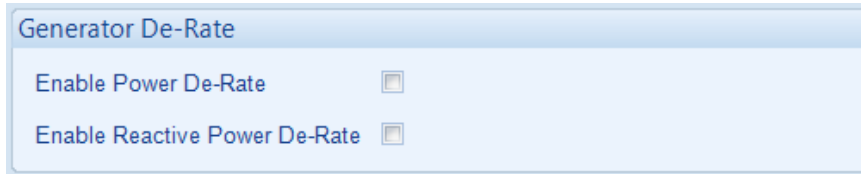

Parameter	Description
Enable Power De-Rate	<input type="checkbox"/> = Power De-Rate is disabled <input checked="" type="checkbox"/> = Power De-Rate is enabled. The Generator kW Rating is De-Rated based on the PLC driven condition.
Enable Reactive Power De-Rate	<p><b>NOTE:</b> When a kvar De-Rate % is applied, the same percentage is used to de-rate both the +kvar &amp; -kvar ratings of the generator.</p> <input type="checkbox"/> = Reactive Power De-Rate is disabled <input checked="" type="checkbox"/> = Reactive Power De-Rate is enabled. The Generator kvar Rating is De-Rated based on the PLC driven condition.

### 3.7.4 GENERATOR VOLTAGE

#### Under Voltage Alarms

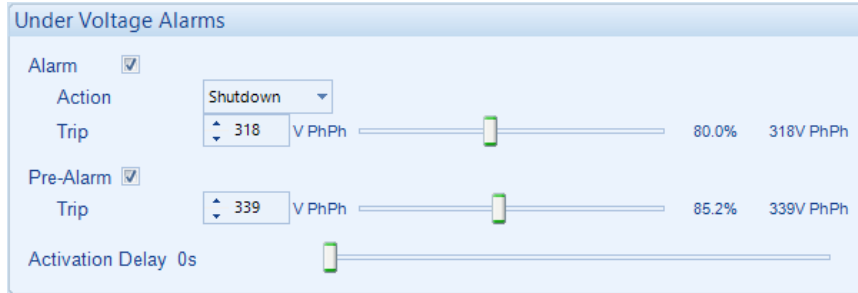

Parameter	Description
Generator Under Voltage Alarm IEEE C37.2 - 27AC Undervoltage Relay	<input type="checkbox"/> = Generator Under Volts does NOT give an alarm <input checked="" type="checkbox"/> = Generator Under Volts gives an alarm in the event of the generator output falling below the configured <i>Under Volts Alarm Trip</i> value for longer than the <i>Activation Delay</i> . The <i>Under-volts Alarm Trip</i> value is adjustable to suit user requirements.
Action	Select the type of alarm required from the list: <b>Electrical Trip</b> <b>Shutdown</b> For details of these, see the section entitled <i>Alarm Types</i> elsewhere in this document.
Generator Under Voltage Pre-Alarm IEEE C37.2 - 27AC Undervoltage Relay	<input type="checkbox"/> = Generator Under Volts does NOT give a Pre-Alarm alarm <input checked="" type="checkbox"/> = Generator Under Volts gives an instantaneous Pre-Alarm in the event of the generator output falling below the configured Under Volts Pre-Alarm Trip value.
Activation Delay	This is used to give a delay on acceptance of the Under Voltage.

**Loading Voltage**

Parameter	Description
Loading Voltage	This is the minimum voltage the generator must be operating at before the module considers it available to take the load. It is also the voltage above the under-voltage trip that the generator output must return to before the module considers that the supply is back within limits. (i.e., With an under-voltage trip of 184 V and a loading voltage of 207 V, the output voltage must return to 207 V following an under-voltage event to be considered within limits.)
Enable Alarm	<input type="checkbox"/> = Alarm is disabled. <input checked="" type="checkbox"/> = Upon starting and after the <i>Safety On Delay Timer</i> expires, if the generator output voltage fails to reach the <i>Loading Voltage</i> set point, the <i>Loading Voltage Not Reached</i> alarm is activated.
Action	Select the type of alarm required from the list: <b>Electrical Trip</b> <b>Indication</b> <b>Shutdown</b> <b>Warning</b> For details of these, see the section entitled <i>Alarm Types</i> elsewhere in this document.

**Nominal Voltage**

Parameter	Description
Nominal Voltage	This is used for synchronising and used to calculate the percentages of the alarm set points and instruct the module what system voltage to adjust the generator to whilst running on load.

**Over Voltage Alarms**

Parameter	Description
Generator Over Voltage Pre-Alarm IEEE C37.2 – 59 AC Overvoltage Relay	<input type="checkbox"/> = Alarm is disabled <input checked="" type="checkbox"/> = Generator Over Volts gives a warning alarm in the event of the generator output voltage rising above the configured <i>Over Volts Pre-Alarm Trip</i> value for longer than the <i>Activation Delay</i> . The <i>Warning</i> is automatically reset when the generator output voltage falls below the configured <i>Return</i> level. The <i>Over Volts Pre-Alarm Trip</i> value is adjustable to suit user requirements.
Generator Over Voltage Alarm IEEE C37.2 – 59 AC Overvoltage Relay	Generator Over Volts gives a <i>Shutdown</i> alarm in the event of the generator output rising above the configured <i>Over Volts Alarm Trip</i> value for longer than the <i>Activation Delay</i> . The <i>Over-volts Alarm Trip</i> value is adjustable to suit user requirements.
Activation Delay	This is used to give a delay on acceptance of the Over Voltage.

### 3.7.5 GENERATOR SEQUENCE ALARMS

#### Zero Sequence Alarm

**Zero Sequence Alarm**

Enable  *Zero Sequence should be set to a third of the required NVD value.*

Action

Arming

Trip  V PhPh  39.8V PhPh

Delay

Parameter	Description
Zero Sequence Alarm IEEE C37.2 – 47H Phase-Sequence or Phase Balance Voltage Relay	<p><b>NOTE:</b> The Zero Sequence Alarm must be set to a third of the required Neutral Voltage Displacement (NVD) value. This is because the summation of the three Zero Sequence vector components is equal to the NVD value.</p> <p>This is also known as Neutral Voltage Displacement.  <input type="checkbox"/> = Alarm is disabled  <input checked="" type="checkbox"/> = The alarm activates when the difference in potential between the Earth and the calculated Neutral position of a 3-wire delta exceeds the configured <i>Zero Sequence Alarm Trip</i> level for the configured <i>Delay</i> time.</p>
Action	<p>Select the type of alarm required from the list:  <b>Electrical Trip</b>  <b>Warning</b>                      For details of these, see the section entitled <i>Alarm Types</i> elsewhere in this document.</p>
Arming IEEE C37.2 -81 Frequency Relay	<p>Select when the alarm becomes active:  <b>Active from Mains Parallel:</b> The <i>Zero Sequence Alarm</i> is monitored when generator and mains are in parallel.  <b>From Safety On:</b> The <i>Zero Sequence Alarm</i> is monitored from the end of the <i>Safety On Delay</i> timer.</p>

**Positive Sequence Alarm**



Parameter	Description
Positive Sequence Alarm IEEE C37.2 – 47L Phase-Sequence or Phase Balance Voltage Relay	<input type="checkbox"/> = Alarm is disabled <input checked="" type="checkbox"/> = The alarm activates when the <i>Positive Sequence</i> voltage falls below the configured <i>Positive Sequence Alarm Trip</i> level for the configured <i>Delay</i> time.
Action	Select the type of alarm required from the list: <b>Electrical Trip</b> <b>Warning</b> For details of these, see the section entitled <i>Alarm Types</i> elsewhere in this document.
Arming	Select when the alarm becomes active: <b>Active From Mains Parallel:</b> The <i>Positive Sequence Alarm</i> is monitored when generator and mains are in parallel <b>From Safety On:</b> The <i>Positive Sequence Alarm</i> is monitored from the end of the <i>Safety On Delay</i> timer.

**Negative Sequence Alarm**

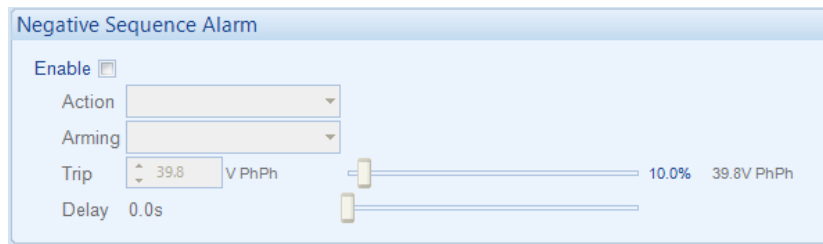

Parameter	Description
Negative Sequence Alarm IEEE C37.2 – 47H Phase-Sequence or Phase Balance Voltage Relay	<input type="checkbox"/> = Alarm is disabled <input checked="" type="checkbox"/> = The alarm activates when the <i>Negative Sequence</i> voltage exceeds the configured <i>Negative Sequence Alarm</i> level for the configured <i>Delay</i> time.
Action	Select the type of alarm required from the list: <b>Electrical Trip</b> <b>Warning</b> For details of these, see the section entitled <i>Alarm Types</i> elsewhere in this document.
Arming	Select when the alarm becomes active: <b>Active From Mains Parallel:</b> The <i>Negative Sequence Alarm</i> is monitored when generator and mains are in parallel <b>From Safety On:</b> The <i>Negative Sequence Alarm</i> is monitored from the end of the <i>Safety On Delay</i> timer.

**Asymmetry Alarm**

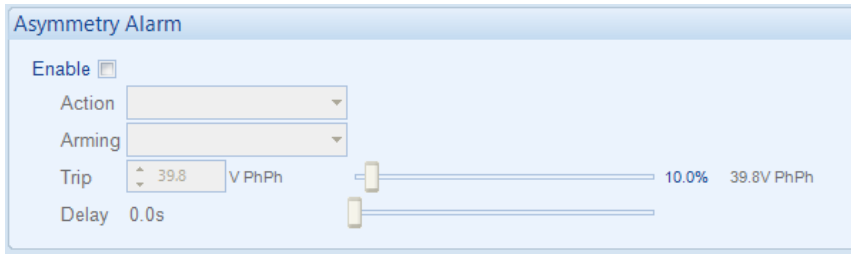

Parameter	Description
Asymmetry Alarm IEEE C37.2 – 59 Overvoltage Relay	<input type="checkbox"/> = Alarm is disabled <input checked="" type="checkbox"/> = The alarm activates when the voltage between any two phases exceeds the configured <i>Asymmetry Alarm Trip</i> level for the configured <i>Delay time</i> . <b>For example:</b> L1=230 V, L2=235 V, L3=226 V Asymmetry is <i>largest value – smallest value</i> = 235 V – 226 V = 9 V
Action	Select the type of alarm required from the list: <b>Electrical Trip</b> <b>Warning</b> For details of these, see the section entitled <i>Alarm Types</i> elsewhere in this document.
Arming	Select when the alarm becomes active: <b>Active From Mains Parallel:</b> The <i>Asymmetry Alarm</i> is monitored when generator and mains are in parallel <b>From Safety On:</b> The <i>Asymmetry Alarm</i> is monitored from the end of the <i>Safety On Delay</i> timer.

### 3.7.6 GENERATOR FREQUENCY

#### Under Frequency Alarms

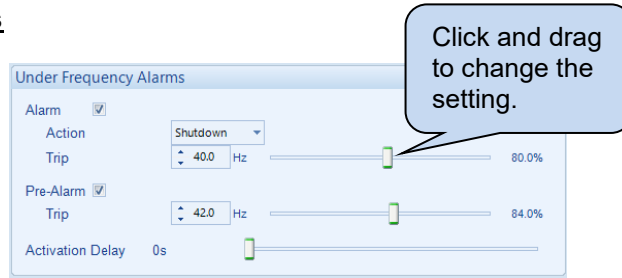

Parameter	Description
Generator Under Frequency Alarm <i>IEEE C37.2 -81 Frequency Relay</i>	<input type="checkbox"/> = Generator Under Frequency does NOT give an alarm <input checked="" type="checkbox"/> = Generator Under Frequency gives an alarm in the event of the generator output frequency falling below the configured <i>Under Frequency Alarm Trip</i> value for longer than the <i>Activation Delay</i> . The <i>Under-frequency Alarm Trip</i> value is adjustable to suit user requirements.
Action	Select the type of alarm required from the list: <b>Electrical Trip</b> <b>Shutdown</b> For details of these, see the section entitled <i>Alarm Types</i> elsewhere in this document.
Generator Under Frequency Pre-Alarm <i>IEEE C37.2 -81 Frequency Relay</i>	<input type="checkbox"/> = Generator Under Frequency does NOT give a Pre-Alarm <input checked="" type="checkbox"/> = Generator Under Frequency gives a Pre-Alarm in the event of the generator output frequency falling below the configured <i>Under Frequency Pre-Alarm Trip</i> value for longer than the <i>Activation Delay</i> . The <i>Under Frequency Pre-Alarm Trip</i> value is adjustable to suit user requirements.
Activation Delay	This is used to give a delay on acceptance of the Under Frequency Alarm.

#### Loading Frequency

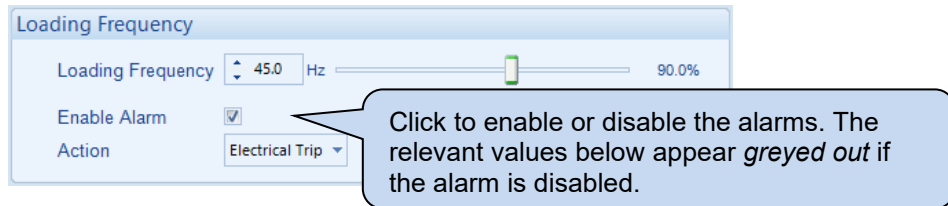

Parameter	Description
Loading Frequency	This is the minimum frequency the generator must be operating at before the module considers it available to take the load. It is also the frequency above the under-frequency trip that the generator output must return to before the module considers that the supply is back within limits. (i.e., With an under-frequency trip of 42.0 Hz and a loading frequency of 45.0 Hz, the output frequency must return to 45.0 Hz following an under-frequency event to be considered within limits.)
Enable Alarm	<input type="checkbox"/> = Alarm is disabled. <input checked="" type="checkbox"/> = Upon starting and after the <i>Safety On Delay Timer</i> expires, if the generator output frequency fails to reach the <i>Loading Frequency</i> set point, the <i>Loading frequency Not Reached</i> alarm is activated.
Action	Select the type of alarm required from the list: <b>Electrical Trip</b> <b>Indication</b> <b>Shutdown</b> <b>Warning</b> For details of these, see the section entitled <i>Alarm Types</i> elsewhere in this document.

**Nominal Frequency**

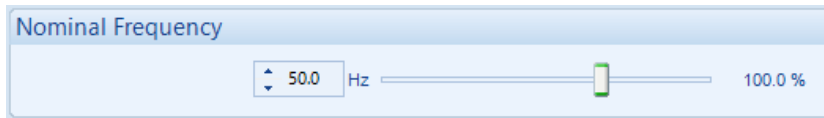

Parameter	Description
Nominal Frequency	This is used to calculate the percentages of the alarm setpoints and instruct the module what frequency to adjust the generator to whilst running on load.

**Over Frequency Alarms**

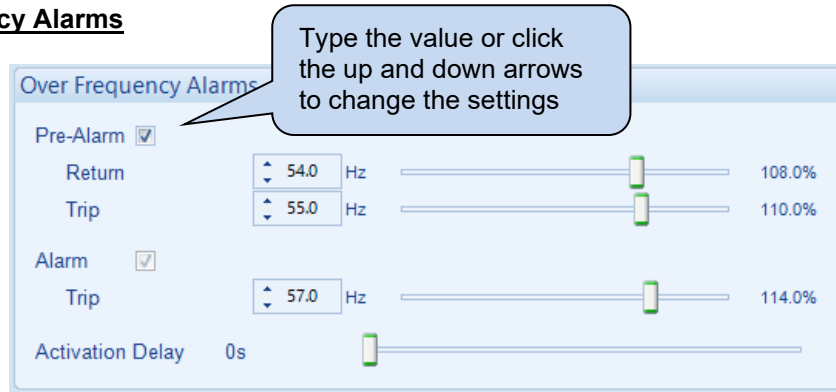

Parameter	Description
Generator Over Frequency Pre-Alarm IEEE C37.2 -81 Frequency Relay	<input type="checkbox"/> = Alarm is disabled <input checked="" type="checkbox"/> = Generator Over Frequency gives a warning alarm in the event of the generator output frequency rising above the configured <i>Over frequency Pre-Alarm Trip</i> value for longer than the <i>Activation Delay</i> . The <i>Warning</i> is automatically reset when the generator output frequency falls below the configured <i>Return</i> level. The <i>Over Frequency Pre-Alarm Trip</i> value is adjustable to suit user requirements.
Generator Over Frequency Alarm IEEE C37.2 -81 Frequency Relay	<input type="checkbox"/> = Alarm is disabled <input checked="" type="checkbox"/> = Generator Over Frequency gives a <i>Shutdown</i> alarm in the event of the generator output rising above the configured <i>Over Frequency Alarm Trip</i> value for longer than the <i>Activation Delay</i> . The <i>Over Frequency Alarm Trip</i> value is adjustable to suit user requirements.
Activation Delay	This is used to give a delay on acceptance of the Over Frequency Alarm.

**Run Away**

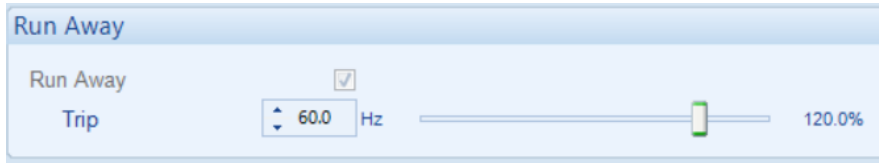

Parameter	Description
Run Away IEEE C37.2 -81 Frequency Relay	<p><b>NOTE:</b> Only available if an electronic engine is connected.</p> <p><input type="checkbox"/> = Alarm is disabled  <input checked="" type="checkbox"/> = In the event of the generator output frequency rising above the configured Trip value, the Run Away Shutdown alarm is immediately triggered.                      This is used to protect against engine damage due to uncontrolled speed increase, where the engine speed runs away.</p>
Trip	Set the frequency level for the Run Away alarm.

**Over Frequency Options**

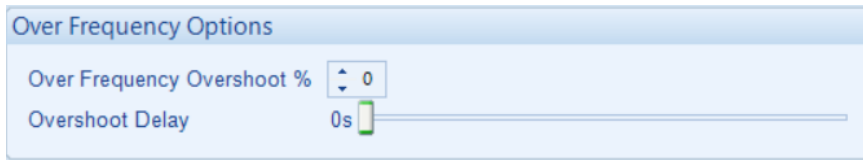

Parameter	Description
Over Frequency Overshoot % IEEE C37.2 -81 Frequency Relay	To prevent spurious over-frequency alarms at start up, the module includes configurable Over Frequency Overshoot protection. This allows the frequency to 'overshoot' the Over-Frequency Shutdown level during the starting process for a short time.
Overshoot Delay	Rather than 'inhibiting' the Over Frequency alarms, the levels are temporarily raised by the Over Frequency Overshoot % for the duration of the Overshoot Delay from starting.

### 3.7.7 GENERATOR CURRENT

The *generator* section is subdivided into smaller sections. Select the required section with the mouse.

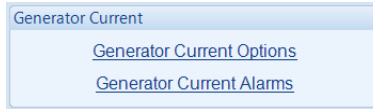

#### 3.7.7.1 GENERATOR CURRENT OPTIONS

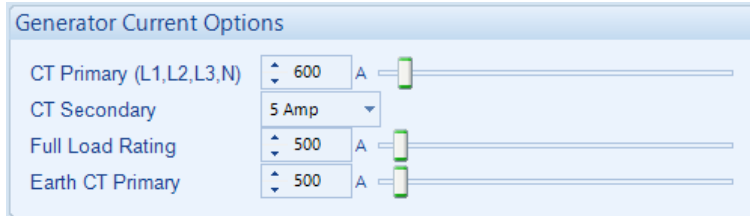

Parameter	Description
CT Primary (L1, L2, L3, N)	Primary rating of the three phase current transformers.
CT Secondary	Secondary rating of all the current transformers, options are: <b>1 Amp</b> <b>5 Amp</b>
Full Load Rating	This is the full load current rating of the alternator.
Earth CT Primary	Primary rating of the earth fault current transformer.

### 3.7.7.2 GENERATOR CURRENT ALARMS

#### Overcurrent Alarm

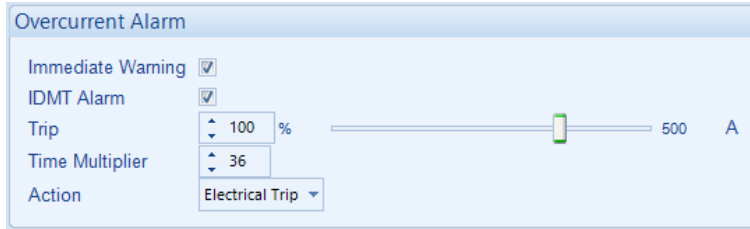

The overcurrent alarm combines a simple warning trip level combined with a fully functioning IDMT curve for thermal protection.

Parameter	Description
Immediate Warning IEEE C37.2 -50 Instantaneous Overcurrent Relay	If the <i>Immediate Warning</i> is enabled, the controller generates a <i>warning alarm</i> as soon as the <i>Trip</i> level is reached. The alarm automatically resets once the generator loading current falls below the <i>Trip</i> level (unless <i>All Warnings are latched</i> is enabled). For further advice, consult the generator supplier.
IDMT Alarm IEEE C37.2 -51 AC Time Overcurrent Relay (shutdown / electrical trip)	If the <i>Over Current IDMT Alarm</i> is enabled, the controller begins following the IDMT 'curve' when the current on any phase passes the <i>Trip</i> setting.  If the <i>Trip</i> is surpassed for an excess amount of time, the <i>IDMT Alarm</i> triggers ( <i>Shutdown</i> or <i>Electrical Trip</i> as selected in <i>Action</i> ).  The larger the over current fault, the faster the trip. The speed of the trip is dependent upon the fixed formula:  $T = \frac{t}{\left(\frac{I_A}{I_T} - 1\right)^2}$  <b>Where:</b> <i>T</i> is the tripping time in seconds <i>I<sub>A</sub></i> is the actual measured current of the most highly loaded line (L1, L2 or L3) <i>I<sub>T</sub></i> is the <i>Trip</i> setting in amps <i>t</i> is the <i>Time Multiplier</i> setting and represents the tripping time in seconds at twice full load (when $I_A/I_T = 2$ ).
Trip	The percentage of alternator full load current at which the IDMT Alarm curve starts to operate from.
Time Multiplier	The time multiplier constant throughout the IDMT curve. It also represents the tripping time in seconds at 200% alternator full load current.
Action	Select the type of alarm required from the list: <b>Electrical Trip</b> <b>Indication</b> <b>Shutdown</b> <b>Warning</b> For details of these, see the section entitled <i>Alarm Types</i> elsewhere in this document.

### Overcurrent Protection Explanation

The settings shown in the example below are a screen capture of the DSE factory settings, taken from the DSE Configuration Suite PC Software for a brushless alternator.

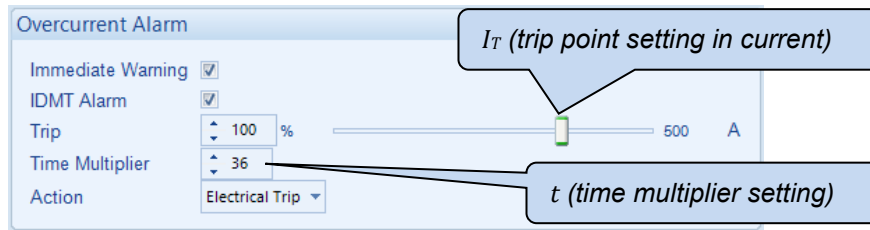

These settings provide for normal running of the generator up to 100% full load. If full load is surpassed, the *Immediate Warning* alarm is triggered, and the set continues to run.

The effect of an overload on the generator is that the alternator windings begin to overheat; the aim of the *IDMT Alarm* is to prevent the windings being overload (heated) too much. The amount of time that the alternator is safely overloaded is governed by how high the overload condition is.

The default settings as shown above allow for an overload of the alternator to the limits of the *Typical Brushless Alternator* whereby 110% overload is permitted for 1 hour or 200% overload is permitted for 36 seconds.

If the alternator load reduces, the controller then *follows* a cooling curve. This means that a second overload condition may trip soon after the first as the controller *knows* if the windings have not cooled sufficiently.

For further details on the *Thermal Damage Curve* of an alternator, refer to the alternator manufacturer and generator supplier.

### Creating A Spreadsheet For the Over Current IDMT Curve

The formula used:

$$T = \frac{t}{\left(\frac{I_A}{I_T} - 1\right)^2}$$

#### Where:

- $T$  is the tripping time in seconds
- $I_A$  is the actual measured current of the most highly loaded line (L1, L2 or L3)
- $I_T$  is the *Trip* setting in amps
- $t$  is the *Time Multiplier* setting and represents the tripping time in seconds at twice full load (when  $I_A/I_T = 2$ ).

The equation is simplified for addition into a spreadsheet. This is useful for 'trying out' different values of  $t$  (*Time Multiplier* setting) and viewing the results, without testing this on the generator.

	A	B	C	D	E	F
1		1.01	1.02	1.03	1.05	1.06
2	36	360000	90000	40000	14400	10000

$t$  (*time multiplier setting*)

$T$  (*tripping time in seconds*)

$I_A/I_T$  (*multiple of the Trip setting from 1.01 to 3.0 in steps of 0.01*)

The formula for the *Tripping Time* cells is:

$=\$A2/POWER((B\$1-1),2)$

### Over Current Alarm IDMT Curves

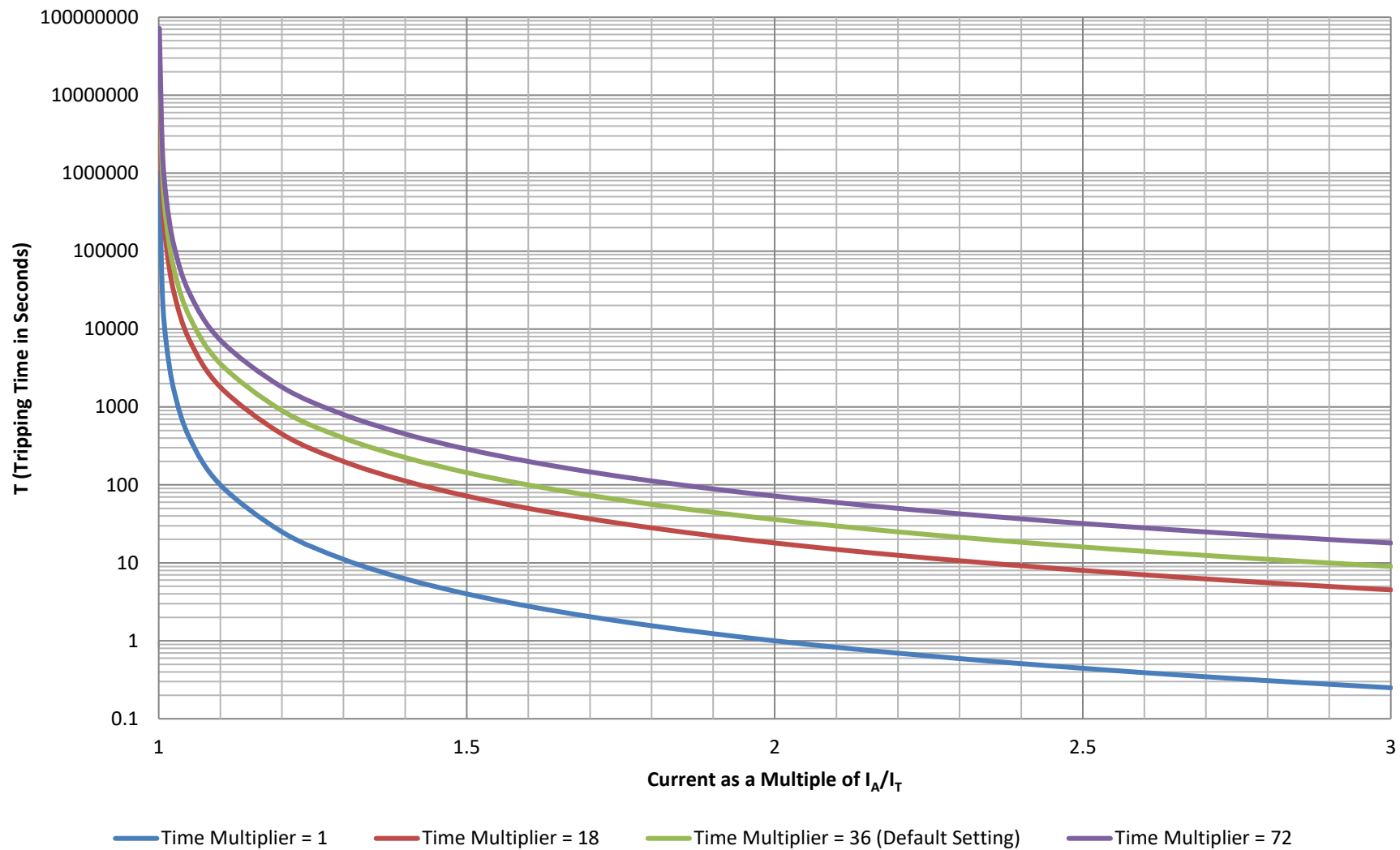

**Unbalanced Current Alarm**

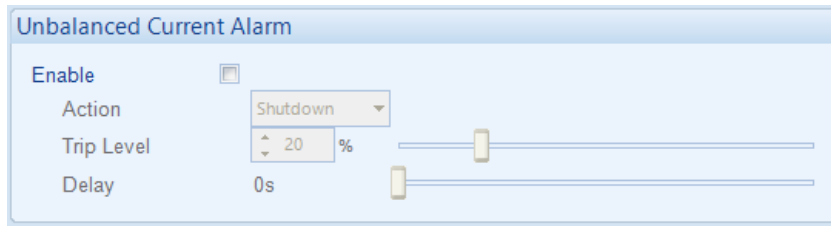

Unbalanced loads cause negative sequence current in the alternator stator. These currents cause harmonics which eventually lead to overheating and melting of the rotor. An unbalanced load is, however, permissible within limits.

For recommended settings contact the alternator manufacturer.

Parameter	
Enable IEEE C37.2 - 46 Phase-Balance Current Relay	<input type="checkbox"/> = The Unbalanced current alarm is disabled <input checked="" type="checkbox"/> = The Unbalanced current alarm is enabled
Action	Select the type of alarm required from the list: <b>Electrical Trip</b> <b>Shutdown</b> <b>Warning</b> For details of these, see the section entitled <i>Alarm Types</i> elsewhere in this document.
Trip Level	The trip as a percentage of alternator full load current
Delay	Set the amount of time before the <i>Negative Phase Sequence</i> activates.

**Short Circuit Alarm**

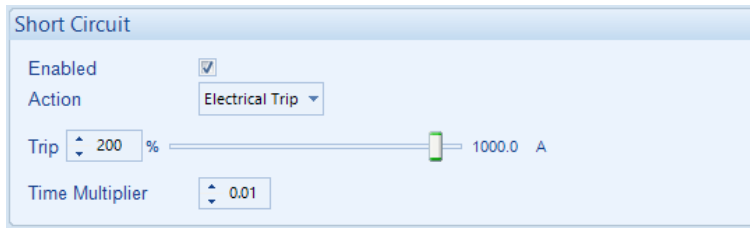

Parameter	Description
Short Circuit Enable IEEE C37.2 – 51 IDMT Short Circuit Relay	<p>If the <i>Short Circuit Alarm</i> is enabled, the controller begins following the IDMT 'curve' when the current on any phase passes the <i>Trip</i> setting.</p> <p>If the <i>Trip</i> is surpassed for an excess amount of time, the <i>IDMT Alarm</i> triggers (<i>Shutdown</i> or <i>Electrical trip</i> as selected in <i>Action</i>).</p> <p>The larger the short circuit fault, the faster the trip. The speed of the trip is dependent upon the fixed formula:</p> $T = \frac{t \times 0.14}{\left(\left(\frac{I_A}{I_T}\right)^{0.02} - 1\right)}$ <p>Where:</p> <ul style="list-style-type: none"> <li><math>T</math> is the tripping time in seconds (accurate to <math>\pm 5\%</math> or <math>\pm 50</math> ms (whichever is greater))</li> <li><math>I_A</math> is the actual measured current</li> <li><math>I_T</math> is the <i>Trip</i> setting in current</li> <li><math>t</math> is the <i>Time Multiplier</i> setting</li> </ul>
Action	<p>Select the type of alarm required from the list:</p> <ul style="list-style-type: none"> <li><b>Electrical Trip</b></li> <li><b>Indication</b></li> <li><b>Shutdown</b></li> <li><b>Warning</b></li> </ul> <p>For details of these, see the section entitled <i>Alarm Types</i> elsewhere in this document.</p>
Trip	The percentage of alternator full load current at which the IDMT Alarm curve starts to operate from.
Time Multiplier	The time multiplier constant throughout the IDMT curve.

### Short Circuit Protection Explanation

The settings shown in the example below are a screen capture of the DSE factory settings, taken from the DSE Configuration Suite software.

**NOTE:** Due to large inrush currents from certain loads, such as motors or transformers, the default settings for the Short Circuit alarm may need adjusting to compensate for normal operating conditions.

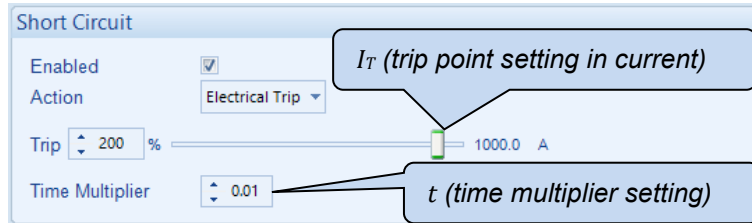

The effect of a short circuit on the generator is that the alternator stator and rotor begin to overheat; the aim of the *IDMT alarm* is to prevent the stator and rotor being overload (heated) too much. The amount of time that the alternator is safely overloaded is governed by how high the short circuit condition is.

For further details on the *Thermal & Magnetic Damage Curve* of your alternator, refer to the alternator manufacturer and generator supplier.

### Creating a Spreadsheet For the Short Circuit IDMT Curve

The formula used:

$$T = \frac{t \times 0.14}{\left(\left(\frac{I_A}{I_T}\right)^{0.02} - 1\right)}$$

Where:

- $T$  is the tripping time in seconds (accurate to  $\pm 5\%$  or  $\pm 50$  ms (whichever is greater))
- $I_A$  is the actual measured current
- $I_T$  is the *Trip* setting in current
- $t$  is the *Time Multiplier* setting

The equation is simplified for addition into a spreadsheet. This is useful for 'trying out' different values of  $t$  (*time multiplier setting*) and viewing the results, without testing this on the generator.

	A	B	C	D	E	F
1		1.01	1.02	1.03	1.05	1.06
2	0.01	7.034242	25	11.11111	4	2.777778

$t$  (*time multiplier setting*)

$T$  (*tripping time in seconds*)

$I_A/I_T$  (*multiple of the Trip setting from 1.01 to 3.0 in steps of 0.01*)

The formula for the *Tripping Time* cells is:

$f_x$  `=(A2*0.14)/(POWER((B$1),0.02)-1)`

### Short Circuit Alarm IDMT Curves

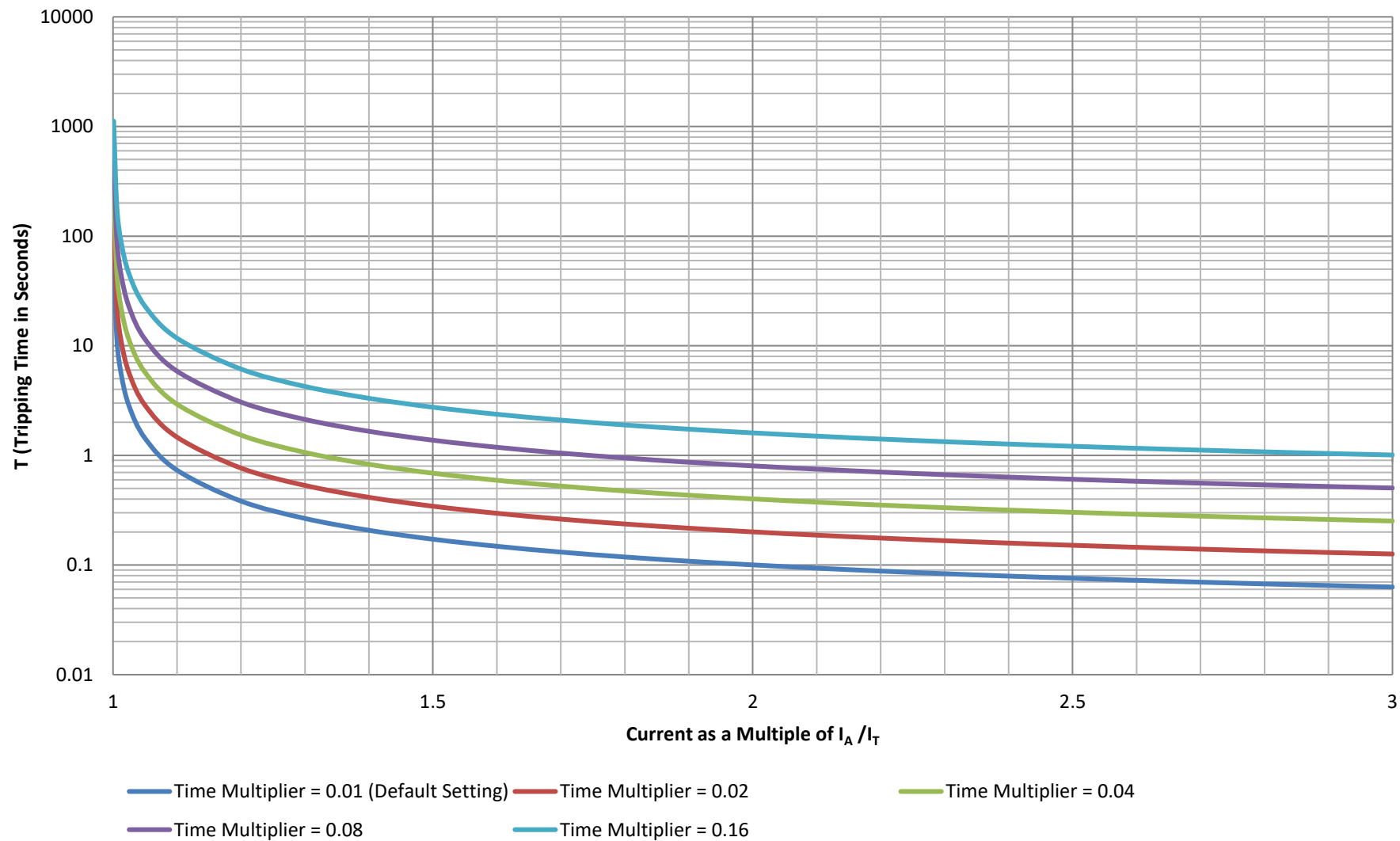

**Earth Fault Alarm**

**NOTE:** The earth current trip triggers on the percentage of the full load current rating. For example, if the CT rating is 750A and the full load current is 500A, then the Earth current at 10% trips at 50A.

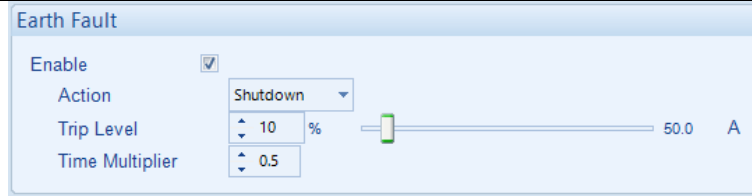

When the module is suitably connected using the 'Earth Fault CT.' The module measures Earth Fault and optionally configured to generate an alarm condition (shutdown or electrical trip) when a specified level is surpassed.

Parameter	Description
Earth Fault Enable IEEE C37.2 – 51 IDMT Earth Fault Relay	<p>If the <i>Earth Alarm</i> is enabled, the controller begins following the IDMT 'curve' when the current on any phase passes the <i>Trip</i> setting.</p> <p>If the <i>Trip</i> is surpassed for an excess amount of time, the <i>IDMT Alarm</i> triggers (<i>Shutdown</i> or <i>Electrical trip</i> as selected in <i>Action</i>).</p> <p>The larger the earth fault, the faster the trip. The speed of the trip is dependent upon the fixed formula:</p> $T = \frac{t \times 0.14}{\left(\left(\frac{I_A}{I_T}\right)^{0.02} - 1\right)}$ <p>Where:</p> <ul style="list-style-type: none"> <li><i>T</i> is the tripping time in seconds (accurate to ±5 % or ±50 ms (whichever is greater))</li> <li><i>I<sub>A</sub></i> is the actual measured current</li> <li><i>I<sub>T</sub></i> is the <i>Trip Level</i> setting in current</li> <li><i>t</i> is the <i>Time Multiplier</i> setting</li> </ul>
Action	<p>Select the type of alarm required from the list:</p> <p><b>Electrical Trip</b> <b>Indication</b> <b>Shutdown</b> <b>Warning</b></p> <p>For details of these, see the section entitled <i>Alarm Types</i> elsewhere in this document.</p>
Trip	The percentage of alternator full load current at which the IDMT Alarm curve starts to operate from.
Time Multiplier	The time multiplier constant throughout the IDMT curve.

**Earth Fault Protection Explanation**

**NOTE:** Due to unbalanced loads or certain types of load, such as an overloaded L1 or variable frequency drives, the default settings for the Earth Fault alarm may need adjusting to compensate for normal operating conditions.

The settings shown in the example below are a screen capture of the DSE factory settings, taken from the DSE Configuration Suite software.

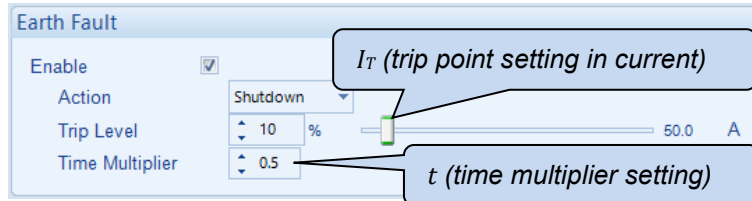

**Creating a Spreadsheet For the Earth Fault IDMT Curve**

The formula used:

$$T = \frac{t \times 0.14}{\left(\left(\frac{I_A}{I_T}\right)^{0.02} - 1\right)}$$

Where:

- $T$  is the tripping time in seconds (accurate to  $\pm 5\%$  or  $\pm 50$  ms (whichever is greater))
- $I_A$  is the actual measured current
- $I_T$  is the trip point setting in current
- $t$  is the time multiplier setting

The equation is simplified for addition into a spreadsheet. This is useful for 'trying out' different values of  $t$  (*time multiplier setting*) and viewing the results, without testing this on the generator.

	A	B	C	D	E	F
1		1.01	1.02	1.03	1.05	1.06
2	0.01	7.034242	25	11.11111	4	2.777778

$t$  (*time multiplier setting*)

$T$  (*tripping time in seconds*)

$I_A / I_T$  (*multiple of the Trip setting from 1.01 to 3.0 in steps of 0.1*)

The formula for the *Tripping Time* cells is:

```
=($A2*0.14)/(POWER((B$1),0.02)-1)
```

### Earth Fault Alarm IDMT Curves

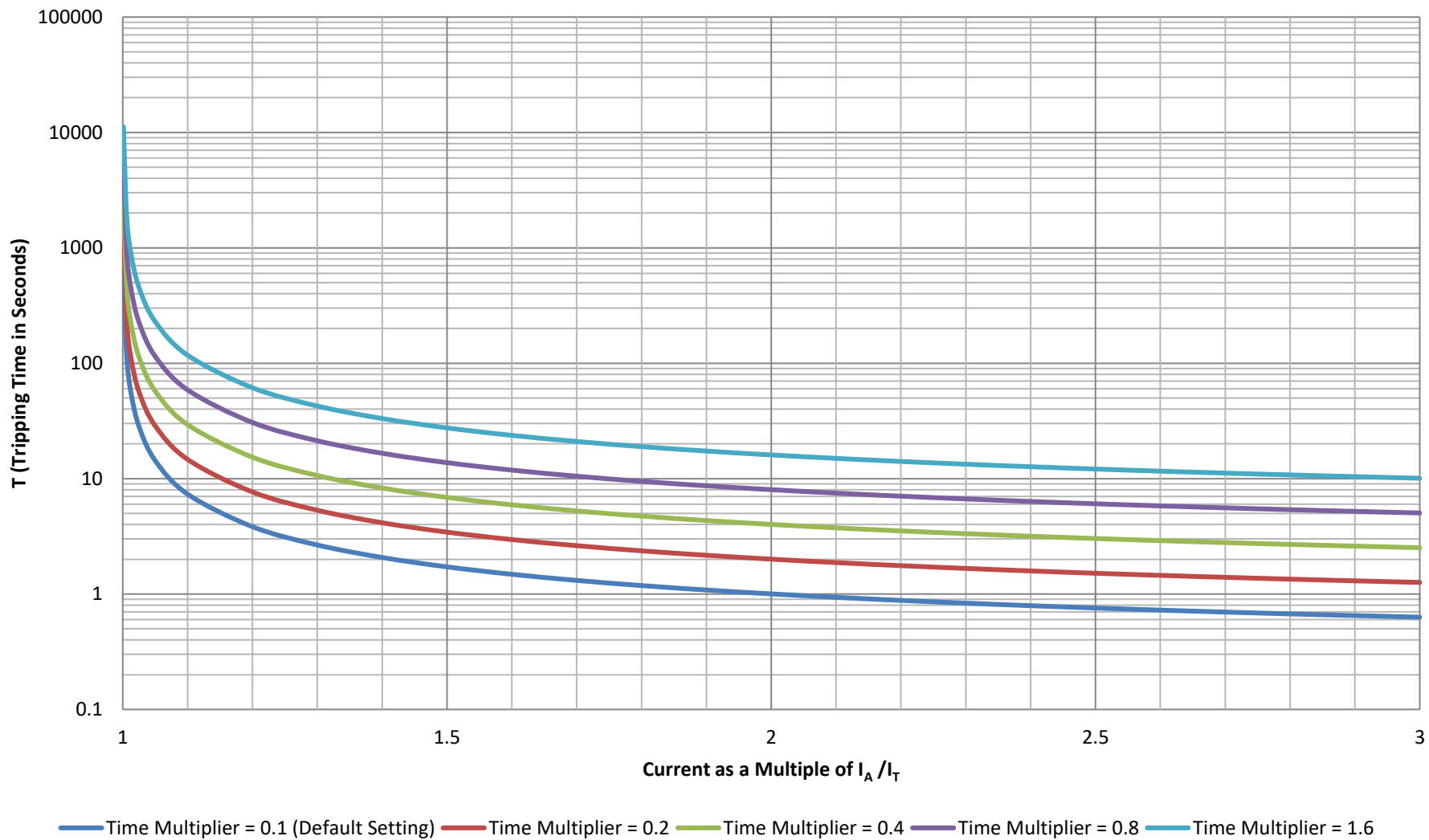

**Instantaneous Overcurrent Alarm**

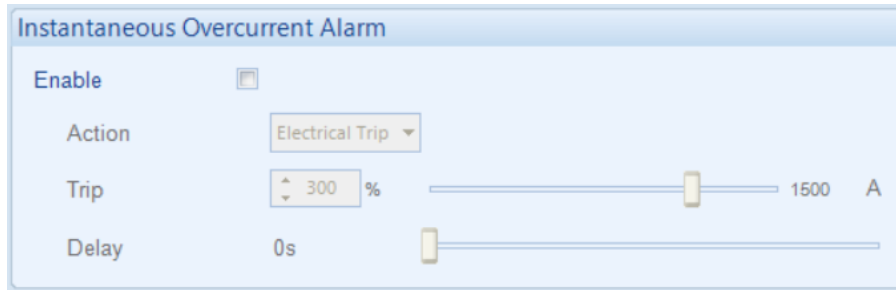

Parameter	Description
Enable <i>IEEE C37.2 - 46 Phase-Balance Current Relay</i>	<input type="checkbox"/> = The Instantaneous Overcurrent alarm is disabled <input checked="" type="checkbox"/> = The Instantaneous Overcurrent alarm is enabled
Action	Select the type of alarm required from the list: <b>Electrical Trip</b> <b>Shutdown</b> For details of these, see the section entitled <i>Alarm Types</i> elsewhere in this document.
Trip	The trip as a percentage of alternator full load current
Delay	The delay before the level of short-circuit current at which the circuit breaker trips

**Arc Reduction Over Current Alarm**

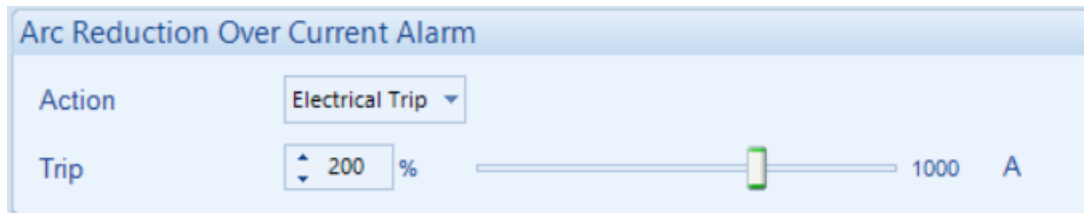

Parameter	Description
Action	Select the type of alarm required from the list: <b>Electrical Trip</b> <b>Shutdown</b> For details of these, see the section entitled <i>Alarm Types</i> elsewhere in this document.
Trip	The trip as a percentage of alternator full load current.

### 3.7.7.2.1 DEFAULT CURRENT PROTECTION TRIPPING CHARACTERISTICS

The graph on the following page shows the default settings for the IDMT tripping curves for the *Over Current*, *Short Circuit* and *Earth Fault* protections.

The default setting for the *Over Current* alarm allows for an overload of an alternator to the limits of the *Typical Brushless Alternator* whereby 110% overload is permitted for 1 hour or 200% overload is permitted for 36 seconds. In an over current situation, the alternator begins to overheat. The aim of the *Over Current IDMT Alarm* is to prevent the windings being overloaded (heated) too much. The amount of time that the alternator is safely overloaded is governed by how high the overload condition is.

The default setting for the *Short Circuit* alarm allows for an alternator to supply a high current caused by a genuine short circuit or an inrush current of a motor or transformer. Whereby 300% overload is permitted for 0.17 seconds or 600% overload is permitted for 0.06 seconds. In a short circuit situation, the alternator begins to overheat to the point the insulation breaks down, potentially causing a fire. The aim of the *Short Circuit IDMT Alarm* is to prevent the insulation from melting due to excessive heat. The amount of time that the alternator is safely in a short circuit condition is governed by the alternator's construction.

The default setting for the *Earth Fault* alarm allows for an alternator to supply a fault current caused by an imbalanced load, a high impedance short to earth or motor drives. Whereby anything less than 10% is considered normal (caused by imbalanced loads) and permitted, 12% fault current is permitted for 3.83 second or 20% fault current is permitted for 1 second.

## DSE Default Configuratuion of Over Current, Short Circuit & Earth Fault IDMT Alarm Curves

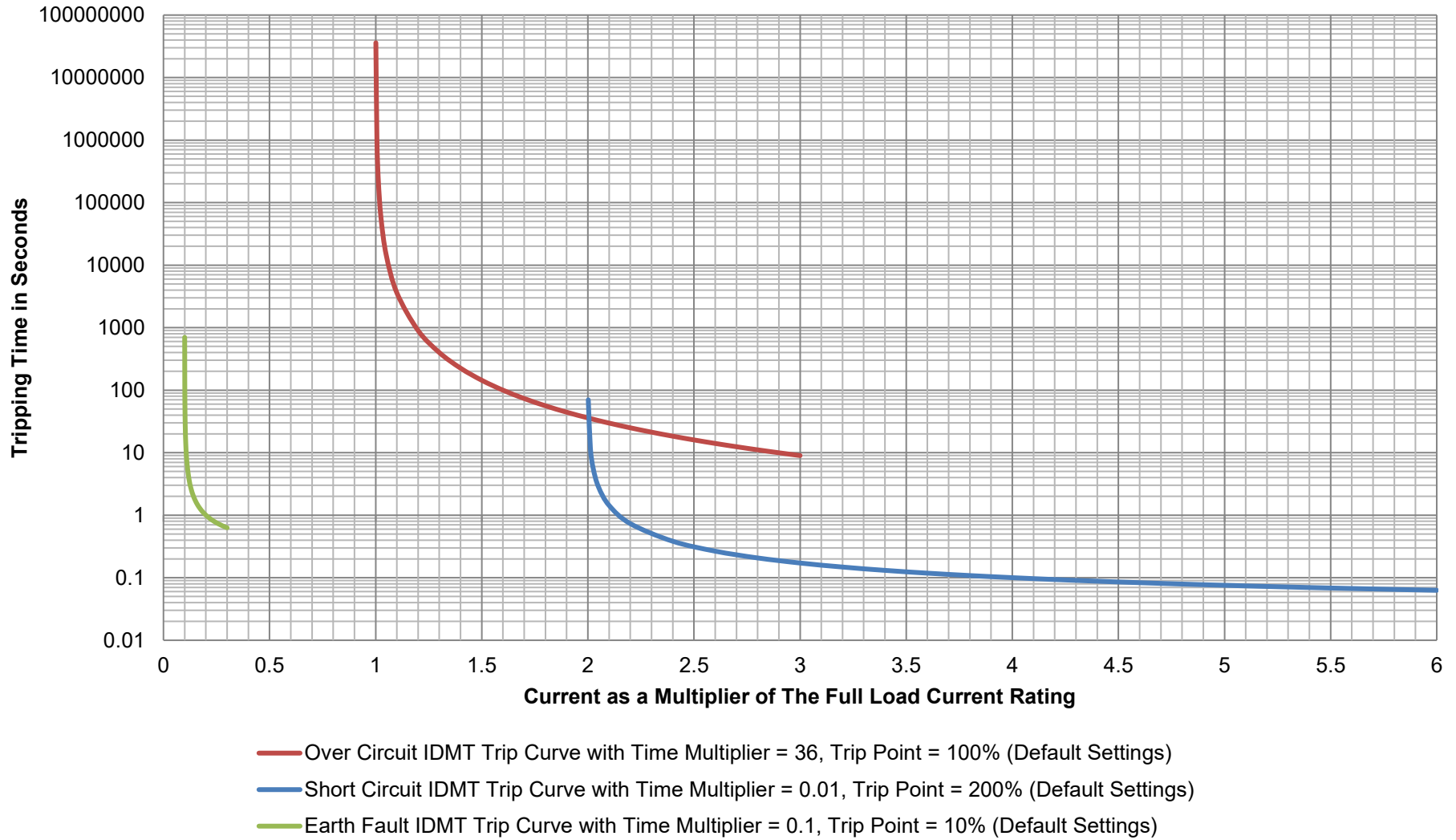

### **3.7.8 GENERATOR POWER**

The *Generator Power* section is subdivided into smaller sections. Select the required section with the mouse.

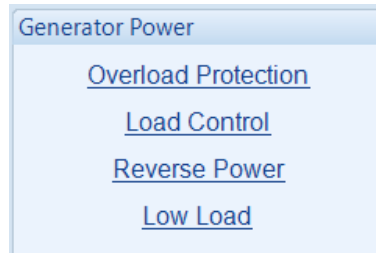

### 3.7.8.1 OVERLOAD PROTECTION

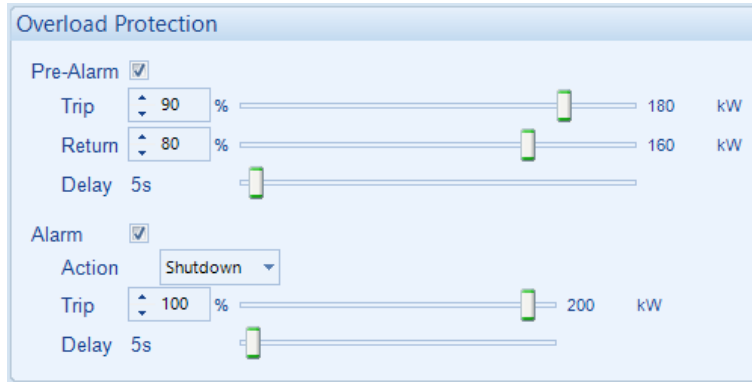

Parameter	Description
Overload Protection Pre-Alarm	<input type="checkbox"/> = Overload Protection Pre-Alarm is disabled. <input checked="" type="checkbox"/> = The <i>kW Overload Pre-Alarm</i> activates when the kW level exceeds the <i>Trip</i> setting for longer than the configured <i>Delay</i> time. The <i>kW Overload Pre-Alarm</i> de-activates when the kW level falls below the <i>Return</i> setting.
Overload Protection Alarm	<input type="checkbox"/> = Overload Protection Alarm is disabled. <input checked="" type="checkbox"/> = The <i>kW Overload Alarm</i> activates when the kW level exceeds the <i>Trip</i> setting for longer than the configured <i>Delay</i> time.
Action	Select the action for the <i>kW Overload Alarm</i> : <b>Electrical Trip</b> <b>Shutdown</b>

### 3.7.8.2 LOAD CONTROL

#### Dummy Load Control

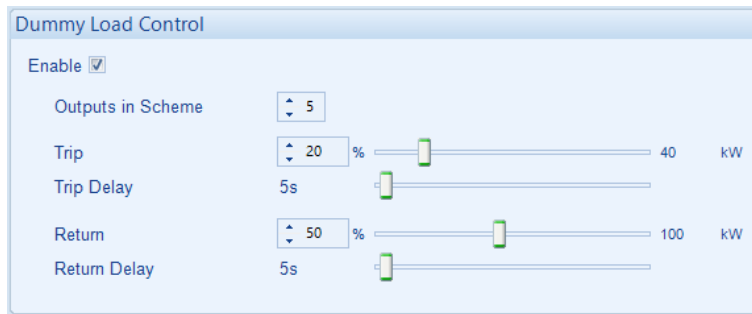

Parameter	Description
Dummy Load Control Enable	Provides control of configurable outputs set to <i>Dummy Load Control</i> . <input type="checkbox"/> = Dummy Load Control is disabled. <input checked="" type="checkbox"/> = The module monitors the load and controls outputs configured to <i>Dummy Load Control (1 to 5)</i> .
Outputs in Scheme	The amount of Dummy Load Control outputs that are included in the function.
Trip / Trip Delay	When the load level is below the <i>Trip</i> setting for the duration of the <i>Trip Delay</i> , then the 'next' output configured to <i>Dummy Load Control</i> is activated (max 5)
Return / Return Delay	When the load level rises above the <i>Return</i> level for the duration of the <i>Return Delay</i> , then the 'highest numbered' output configured to <i>Dummy Load Control</i> is de-activated, and the timer is reset.

**Load Shedding Control**

Parameter	Description
Load Shedding Control Enable	Provides control of configurable outputs set to <i>Load Shedding Control</i> . <input type="checkbox"/> = Load Shedding Control is disabled. <input checked="" type="checkbox"/> = The module monitors the load and controls any outputs configured to <i>Load Shedding Control (1 to 5)</i> .
Outputs in Scheme	The number of outputs (max 5) that are included in the function.
Outputs at Start	The number of outputs configured to Load Shedding Control (1 to 5) that are energised before set is required to take load.
Trip / Trip Delay	When the load level is above the <i>Trip</i> setting for the duration of the <i>Trip Delay</i> , then the 'next' output configured to <i>Load Shedding Control</i> is activated (max 5)
Return / Return Delay	When the load level is below the <i>Return</i> setting for the duration of the <i>Return Delay</i> , then the 'highest numbered' output configured to <i>Load Shedding Control</i> is de-activated, and the timer is reset.

### 3.7.8.3 REVERSE POWER

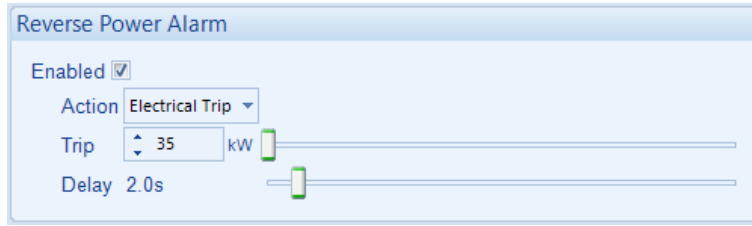

Parameter	Description
Reverse Power Alarm Enable IEEE C37.2 – 32 Directional Power Relay	<input type="checkbox"/> = <i>Generator Reverse Power Alarm</i> is disabled. <input checked="" type="checkbox"/> = The <i>Generator Reverse Power Alarm</i> activates when the reverse power exceeds the <i>Reverse Power Trip</i> setting longer than the configured <i>Delay</i> time. This is used to protect against back feed from electric motors when mechanically overpowered.
Action	Select the action for the <i>Reverse Power Alarm</i> : <b>Electrical Trip</b> <b>Indication</b> <b>Shutdown</b> <b>Warning</b>

### 3.7.8.4 LOW LOAD

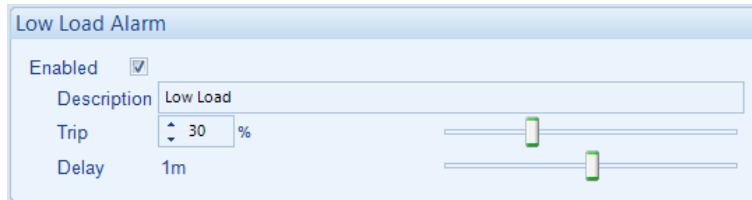

Parameter	Description
Low Load Alarm Enable	<input type="checkbox"/> = <i>Low Load Alarm</i> is disabled. <input checked="" type="checkbox"/> = The <i>Low Load Alarm</i> activates when the generator power drops below the configured <i>Trip</i> setting longer than the configured <i>Delay</i> time. This is used to prevent the engine from running at very low load levels.
Description	Enter the LCD text that shows up on the display when this alarm activates.
Trip	Set the percentage of total power at which the <i>Low Load Alarm</i> is activated.
Delay	Set the amount of time before the <i>Low Load Alarm</i> activates.

### 3.7.9 SYNCHRONISING

The *Synchronising* section is subdivided into smaller sections. Select the required section with the mouse.



### 3.7.9.1 SYNC OPTIONS

#### Options

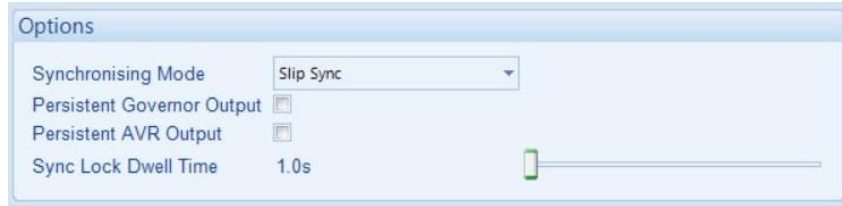

Parameter	Description
Synchronising Mode	<p>The following options are available.</p> <p><b>Sync Lock:</b> This is used to hold a generator in sync with another ac source without closing the breaker.</p> <p><b>Disabled:</b> Synchronising control disabled.</p> <p><b>Slip Sync:</b> The ac source under control will be driven past the second source and the breaker will close when the settings criteria are met.</p>
Persistent Governor Output	<p>Configures the action to take when transitioning from <i>Synchronising</i> to <i>Load Sharing</i> (at the point of closing the load switch device into parallel with another supply).</p> <p><input type="checkbox"/> = Analogue GOV output resets to <i>Centre</i> (SW1 setting) when the load switch device is closed.</p> <p><input checked="" type="checkbox"/> = Analogue GOV output retains the value achieved during the synchronising process.</p>
Persistent AVR Output	<p>Configures the action to take when transitioning from <i>Synchronising</i> to <i>Load Sharing</i> (at the point of closing the load switch device into parallel with another supply).</p> <p><input type="checkbox"/> = Analogue AVR output resets to <i>Centre</i> (SW1 setting) when the load switch device is closed.</p> <p><input checked="" type="checkbox"/> = Analogue AVR output retains the value achieved during the synchronising process.</p>
Sync Lock Dwell Time	<p>The time the ac sources must remain within the sync window before the breaker is closed.</p>

**Governor**

Example:  
If the voltage is set at 2.5v, the range is from -2.5v to 7.5v.

Parameter	Description
Governor Interface	Select the desired interface setting: <b>0-20mA</b> <b>4-20 mA</b> <b>Voltage (10v range within -10v to +10v limits).</b>
Governor Output Reversed	<input type="checkbox"/> = Lower analogue output voltage equates to lower engine speed. <input checked="" type="checkbox"/> = Lower analogue output voltage equates to higher engine speed.
Action	<p><b>▲ NOTE: This determines the modules frequency control when the generator is running on load and not in parallel.</b></p> <p><b>Adjust to Centre Point:</b> When the generator's switchgear has closed, the generator's frequency is pre-determined by <i>SW1</i> setting for the governor. For further information about the <i>SW1</i> setting refer to the section entitled <i>Governor / AVR Interface</i> elsewhere in this document.</p> <p><b>Adjust to Nominal:</b> When the generator's switchgear has closed, the generator's frequency is continually adjusted to the <i>Nominal Frequency</i> setting for the generator. For further information about the <i>Nominal Frequency</i> setting refer to the section entitled <i>Generator Frequency</i> elsewhere in this document.</p> <p><b>None:</b> When the generator's switchgear has closed, the generator's frequency is not controlled by the module. The frequency control is achieved using external 3<sup>rd</sup> party equipment.</p>

**AVR**

AVR	
Output	Voltage
Output Reversed	<input type="checkbox"/>
Action	Adjust To Nominal Voltage

Parameter	Description
AVR Output	<p>Select the desired interface setting:  <b>0-20mA</b>  <b>4-20 mA</b>  <b>Voltage</b>  <b>None:</b> The module does not interface with the generator's AVR, voltage and kvar control is achieved using external 3<sup>rd</sup> party equipment.</p>
AVR Output Reversed	<p><b>⚠ NOTE: Only available when internal analogue is selected. This allows the module to interface with a greater diversity of AVRs.</b></p> <p><input type="checkbox"/> = Lower analogue output voltage equates to lower alternator voltage.  <input checked="" type="checkbox"/> = Lower analogue output voltage equates to higher alternator voltage.</p>
Action	<p><b>⚠ NOTE: This setting determines the voltage control when the generator is running on load and not in parallel only.</b></p> <p><b>Adjust to Centre Point:</b> When the generator's switchgear has closed, the generator's voltage is pre-determined by <i>SW1</i> setting for the AVR. For further information about the <i>SW1</i> setting refer to the section entitled <i>Governor / AVR Interface</i> elsewhere in this document.</p> <p><b>Adjust to Nominal Voltage:</b> When the generator's switchgear has closed, the generator's voltage is pre-determined by <i>Nominal Voltage</i> setting for the generator. For further information about the <i>Nominal Voltage</i> setting refer to the section 3.7.4 entitled <i>Generator Voltage</i> in this document elsewhere in this document.</p> <p><b>None:</b> When the generator's switchgear has closed, the generator's voltage is not controlled by the module. The voltage control is achieved using external 3<sup>rd</sup> party equipment.</p>

### 3.7.9.2 CHECK SYNC

#### Dead Bus

**NOTE:** If a module on the AMSC indicates that the segment is live, and the module measures a dead bus an alarm is raised.

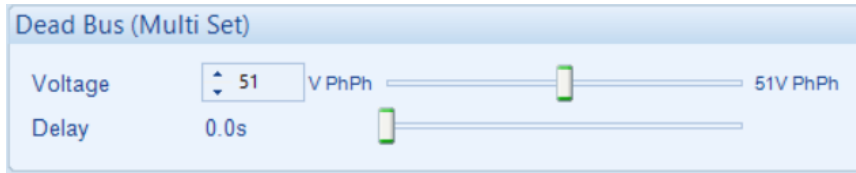

Dead Bus detection is used in two scenarios:

- If the bus is dead, controller(s) communicate over the AMSC link to determine which one closes to the dead bus. If the bus is live, synchronisation takes place before the load switch is closed.
- Upon closing the load switch, the bus must be seen to be 'not dead' a short time later.

Parameter	Description
Voltage	The voltage below which the bus is assumed to be 'dead.'
Delay	When the load switch is closed, the bus voltage is measured a short time later, determined by <i>Delay</i> . If the bus voltage is below the level of the <i>Dead Bus Voltage</i> setting, the <i>Bus Not Live</i> electrical trip alarm is raised.

#### Check Sync

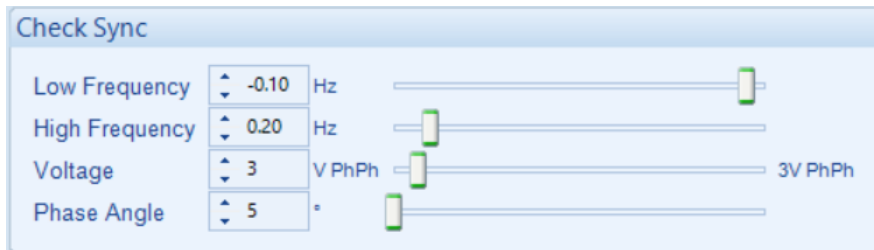

During the synchronising process, the controller adjusts the frequency and voltage of the generator to closely match the existing bus. Typically, the oncoming set is adjusted to be 0.1 Hz faster than the existing supply, this causes the phase of the two supplies to change continuously.

Before the breaker is closed, the following configurable conditions must be met.

Parameter	Description
Low Frequency High Frequency	The difference between the two supplies frequencies must be between the <i>Check Sync Low Frequency</i> and <i>Check Sync High Frequency</i> .
Voltage	The difference between the two supply voltages must be equal to or below the <i>Check Sync Voltage</i> . Where different nominal voltages are used (e.g., when a transformer is present) the proportional difference is calculated.
Phase Angle	The phase of the two supplies must be equal to or below the <i>Check Sync Phase Angle</i> .

**Fail to Sync Alarm**

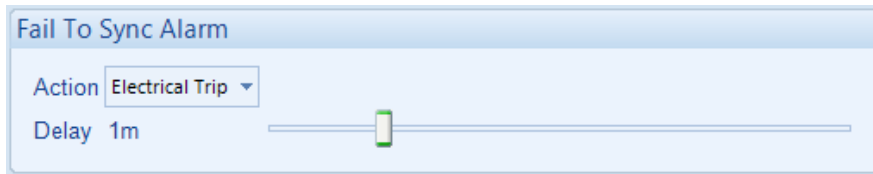

Used to detect that the synchronising process is taking a long time. This occurs when changes in the load are making the set control difficult due to changes in voltage and frequency.

Parameter	Description
Action	<p>Determines the action to take upon a <i>Fail to Sync</i>.</p> <p><b>Electrical Trip:</b> The set is stopped. In a <i>Load Demand</i> scheme, other generators start if available.</p> <p><b>Indication:</b> The set continues to synchronise, and no alarm is raised. This is used for internal use, such as in the <i>PLC Logic</i> or <i>Virtual LEDs</i>.</p> <p><b>Warning:</b> The set continues to attempt to synchronise.</p>
Delay	<p>The time to allow for successful synchronisation to take place. If the process continues longer than <i>Delay</i>, the <i>Action</i> above is taken.</p>



### 3.7.9.3 AMSC LINK

**NOTE:** The AMSC Link Alarms are disabled by a digital input configured to *AMSC Alarms Inhibit* if required.

**NOTE:** When the Redundant AMSC link (AMSC 2) is enabled but AMSC1 is not wired then a warning alarm will be triggered.

Parameter	Description
AMSC Failure Action	Action upon AMSC Link Failure:  <b>Electrical Trip:</b> The breaker is opened immediately, and the cooling timer begins, after which the set is stopped. <b>Indication:</b> The set continues to run, and no alarm is raised. This is used for internal use, such as in the <i>PLC Logic</i> or <i>Virtual LEDs</i> . <b>Warning:</b> The set continues to run, and a warning alarm is activated.
AMSC Alarms Disabled Action	Action to take when the AMSC alarms are disabled by a digital input:  <b>Indication:</b> The set continues to run, and no alarm is raised. This is used for internal use, such as in the <i>PLC Logic</i> or <i>Virtual LEDs</i> . <b>None:</b> Alarm is disabled. <b>Warning:</b> The set continues to run, and a warning alarm is activated.
Too Few Modules Action	Action to take when the number of modules active on the AMSC link is lower than the <i>Minimum Modules on AMSC link</i> setting.  <b>Electrical Trip:</b> The breaker is opened immediately, and the cooling timer begins, after which the set is stopped. <b>Indication:</b> The set continues to run, and no alarm is raised. This is used for internal use, such as in the <i>PLC Logic</i> or <i>Virtual LEDs</i> . <b>None:</b> Alarm is disabled and the output source. <b>Warning:</b> The set continues to run, and a warning alarm is activated.

Parameters continued overleaf...

Parameter	Description
Minimum Modules On AMSC Link	Set the minimum number of modules on the AMSC before the <i>Too Few Modules</i> alarm is activated. The maximum number of Minimum Modules is 32.
Enable Redundant AMSC Link	<input type="checkbox"/> = Only one Multi-Set Comms (AMSC) Link is active. <input checked="" type="checkbox"/> = This activates the second (redundant) Multi-Set Comms (AMSC) Link, allowing for communications redundancy between the controllers.
Disable Auto ID Allocation	<input type="checkbox"/> = The AMSC system assigns the AMSC ID automatically when the DSE module powered over the AMSC network. <input checked="" type="checkbox"/> = The AMSC system does not assign the AMSC ID automatically when the DSE module is powered up, instead the DSE module uses the <i>AMSC ID</i> number configured in this section up to a maximum of 64.
Bus Segment Number	<div style="border: 2px solid black; padding: 5px; margin-bottom: 10px;">  <b>WARNING!: This is critical for safe control!</b> </div> <p>Each section of the ac bus requires a unique identifier number. All modules connected to the same section or segment must have the same number. A maximum of 64 Bus Segment Numbers are used.</p>
Bus Sensing Failure Action	<p><b>Electrical Trip:</b> The breaker is opened immediately, and the cooling timer begins, after which the set is stopped.</p> <p><b>Shutdown:</b> The breaker is opened immediately, and the set is immediately stopped.</p> <p><b>Warning:</b> The set continues to run, and a warning alarm is activated.</p> <div style="border: 2px solid black; padding: 5px; margin-top: 10px;">  <b>NOTE: The Dead Bus voltage is used as the threshold for Bus Sensing Failure.</b> </div>

### 3.7.9.4 LOAD CONTROL



**NOTE:** The *Minimum Load Level* and *Maximum Load Level* are configured within the SCADA section. For further details, refer to the section entitled *Load Levels* contained within the SCADA section elsewhere in this document.

When any of the following *Load Control* modes are selected, the controller performs a 'soft' load transfer when taking or removing a load.

Upon generator's switchgear closing, the module controls the generator's power production starting from the *Minimum Load Level* setting. Load is then applied to the generator at the configured *Ramp Up Rate*. The ramping continues until the generator is producing an equal percentage of full load power as the other generators on the bus, or to the *Maximum Load Level* when running in *Mains Parallel Mode*.

When a paralleled generator leaves the bus, the load is ramped down to the *Minimum Load Level* at the configured *Ramp Down Rate*. The generator's switchgear is opened once the *Minimum Load Level* or *Ramp Minimum time to Ramp Down* has been attained, removing the generator from the bus.

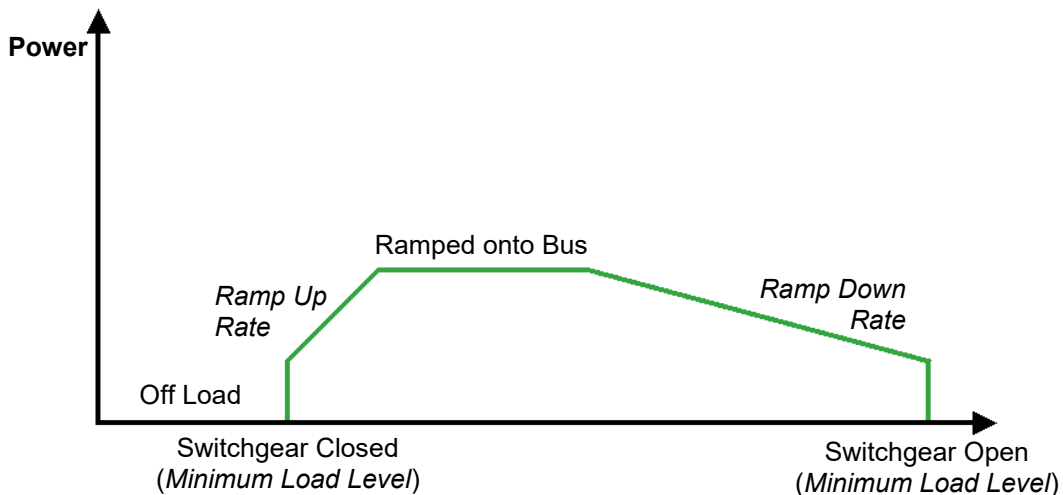

'Soft' load transfers of this type have many benefits, the most obvious are:

- When the generator is removed from the bus, other sets in the system are not suddenly loaded with the load that was being supplied by the generator being removed. Instead, the load is slowly ramped, allowing time for the remaining sets to take up their share of the load.
- Opening of the load switch occurs at a much lower load level, helping to reduce arcing of the contacts.

3.7.9.4.1 LOAD CONTROL (MULTI SET)

**Load Options**

Load Control Mode kW Share ▾

Enable Droop on AMSC Failure

AMSC Return Timer 0s

Control Curve 3.33% Droop: 2.5% Nominal Offset ▾ Edit...

Ramp Rate 0.1 %  %/s

---

Reactive Load Control Mode kVAr Share ▾

Enable Droop on AMSC Failure



AMSC Return Timer 0s

Control Curve 4.73% Droop: -33%,3.6% Offset ▾ Edit...

Ramp Rate 0.1 %  %/s

Parameter	Description
Load Control Mode IEEE C37.2 -90 Regulating device	<div style="border: 1px solid black; padding: 5px;"> <p><b>NOTE:</b> The module automatically switches from <i>kW Load Control</i> mode to <i>kW Power Control</i> mode when an input configured for <i>Mains Parallel Mode</i> is active. For further details refer to the section entitled <i>Power Control elsewhere in this document</i>.</p> </div> <p><b>Droop:</b> The module synchronises the generator to the generator bus and controls the kW load sharing using droop. Droop based kW load sharing ensures that the generators produce an equal percentage of kW by varying frequency. Droop based kW load sharing is possible between generators that are not fitted with DSE modules and have frequency droop enabled.</p> <p><b>kW Share:</b> The module synchronises the generator to the generator bus and controls the kW load sharing isochronously between DSE modules. Isochronous kW load sharing ensures that the generators produce an equal percentage of kW whilst maintaining nominal frequency. Isochronous kW load sharing is only possible when using the AMSC link between DSE modules.</p> <p><b>kW Share + Droop:</b> The module synchronises the generator to the generator bus and controls the kW load sharing isochronously between DSE modules. The kW load control is switched from isochronous to droop either by activating a digital input, AMSC Failure or GenComm request based upon user configuration.</p> <p><b>None:</b> The module synchronises the generator to the generator bus but once in parallel, does not actively control the kW load sharing. This is left to external 3<sup>rd</sup> party devices such as external load share controller or droop configured on the engine governor.</p>

Parameter descriptions are continued overleaf...

Parameter	Description
Enable Droop on AMSC Failure	<p> <b>NOTE: Only available when <i>Load Control Mode</i> is configured as <i>kW Share + Droop</i>.</b></p> <hr/> <p> <b>NOTE: Do not use this option when bank controllers are included as part of the system, as an AMSC failure is only visible on the primary bus and sets on the Group bus continue to run in load share mode (or vice versa).</b></p> <p><input type="checkbox"/> = It is not possible to switch kW isochronous to droop load sharing by when the AMSC link fails.  <input checked="" type="checkbox"/> = The module switches from kW isochronous to droop load sharing when the AMSC link fails. The module reverts to kW isochronous load sharing once the AMSC link returns for longer than the <i>AMSC Return Timer</i>.</p>
AMSC Return Timer	<p>The timer waits for a set value in seconds for the AMSC alarms to clear to allow the module to switch back to kW isochronous load sharing.</p>
Control Curve	<p> <b>NOTE: It is advised that all generators in the system have the same droop curve configured to ensure equal percentage of kW load sharing between them.</b></p> <p>Select the required droop curve from a pre-defined list or create a user-defined curve.  <i>Droop</i> is the percentage of nominal frequency that the generator's frequency decreases by as the load varies from 0 % to 100 % of the kW rating of the generator.  <i>Nominal Offset</i> is the percentage above/below the nominal frequency in which the droop starts from.  A <i>Droop</i> of 5% with a <i>Nominal Offset</i> of 3% on a 50 Hz system would result in the generator running at 51.5 Hz (103% of nominal) at 0 % kW and 49 Hz (98% of nominal) at 100 % kW with a linear change between them.</p>
Ramp Rate	<p>The rate at which the generator kW is ramped onto and off the load when using Droop.</p>

Parameter descriptions are continued overleaf...

Parameter	Description
Reactive Load Control Mode IEEE C37.2 -90 Regulating device	<p><b>▲ NOTE: Reactive Load Control Mode is forced to None when Load Control Mode set to None.</b></p> <p><b>▲ NOTE: The module automatically switches from <i>kvar Load Control</i> mode to <i>kvar Power Control</i> mode when an input configured for <i>Mains Parallel Mode</i> is active. For further details refer to section entitled <i>Power Control</i> elsewhere in this document.</b></p> <p><b>Droop:</b> The module synchronises the generator to the generator bus and controls the kvar load sharing using droop. Droop based kvar load sharing ensures that the generators produce an equal percentage of kvar by varying voltage. Droop based kvar load sharing is possible between generators that are not fitted with DSE modules also have voltage droop enabled.</p> <p><b>kvar Control:</b> The module synchronises the generator to the generator bus and controls the kvar by forcing it to a pre-determined value.</p> <p><b>kvar Share:</b> The module synchronises the generator to the generator bus and controls the kvar load sharing between DSE modules. Isochronous kvar load sharing ensures that the generators produce an equal percentage of kvar whilst maintaining nominal voltage. kvar load sharing is only possible when using the AMSC link between DSE modules.</p> <p><b>kvar Share + Droop:</b> The module synchronises the generator to the generator bus and controls the kvar load sharing between DSE modules. The kvar load control is switched from isochronous to droop either by activating a digital input, AMSC Failure or GenComm request based upon user configuration.</p> <p><b>None:</b> The module synchronises the generator to the generator bus but once in parallel, does not actively control the kvar load sharing. This is left to external 3<sup>rd</sup> party devices such as external load share controller or droop configured on the alternator AVR.</p>
Enable Droop on AMSC Failure	<p><b>▲ NOTE: Only available when Load Control Mode is configured as <i>kvar Share + Droop</i>.</b></p> <p><input type="checkbox"/> = It is not possible to switch kvar to droop load sharing by when the AMSC link fails.</p> <p><input checked="" type="checkbox"/> = The module switches from kvar to droop load sharing when the AMSC link fails. The module reverts to kvar isochronous load sharing once the AMSC link returns for longer than the <i>AMSC Return Timer</i>.</p>
AMSC Return Timer	The timer waits for a set value in seconds for the AMSC link to return to allow the module to switch back to kvar load sharing.

Parameter descriptions are continued overleaf...

Parameter	Description
Control Curve	<p><b>⚠ NOTE: It is advised that all generators in the system have the same droop curve configured to ensure equal percentage of kvar load sharing between them.</b></p> <p>Select the required droop curve from a pre-defined list or create a user-defined curve.</p> <p><i>Droop</i> is the percentage of nominal voltage that the generator's voltage decreases by as the load varies from 0 % to 100 % of the kvar rating of the generator.</p> <p><i>Nominal Offset</i> is the percentage above/below the nominal voltage in which the droop starts from.</p> <p>A <i>Droop</i> of 5% with a <i>Nominal Offset</i> of 3% on a 400 V system would result in the generator running at 412 V (103% of nominal) at 0 % kvar and 392 V (98% of nominal) at 100 % kvar with a linear change between them.</p>
Ramp Rate	The rate at which the generator kvar is ramped onto and off the load when using Droop.

**Load Share Ramp**

Load Share Ramp

Ramp Up Rate: 3.0 %

Ramp Down Rate: 3.0 %

Maximum Time to Ramp Down: 20s

Parameter	Description
Ramp Up Rate	<p><b>⚠ NOTE: The set initially takes load at the level set by the <i>Minimum Load Level</i> and then increases its load at this rate until the generated power is equal to the setting for <i>Load Parallel Power</i>.</b></p> <p>The percentage rate at which the generator is ramped onto the load.</p>
Ramp Down Rate	<p><b>⚠ NOTE: When the set is unloaded, it ramps down at this rate from the current load level to the level set by the <i>Minimum Load Level</i> before being removed from the bus.</b></p> <p>The percentage rate at which the generator is ramped off the load.</p>
Maximum Time to Ramp Down	<p>This is to set a time limit to the ramp down process, and it is useful when the engine response is slow or is not capable to ramp off the load.</p> <p>The <i>Ramp Off Load</i> timer starts when the generator begins to ramp down. When this timer is expired the breaker opens regardless of the actual power.</p> <p>It is possible to set the ramp rate slower than this time, so the breaker opens prior to the ramp finishes.</p>

**Example**

There is a requirement for a ramp down rate from 100 to 0% during a period of 20 secs. This is calculated as follows.

$$\frac{\text{Ramp Down Rate}}{\text{Time Period (secs)}} = \text{Ramp Down Rate \%} \quad \frac{100}{20} = 5\%$$

**G0123**

**NOTE:** It is the user's responsibility to ensure the generator on the analogue load share lines is on load and not in fixed power mode, otherwise ramping will cause the frequency to ramp until an alarm trips.

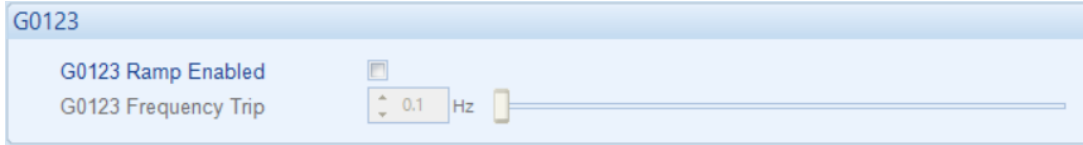

Parameter	Description
G0123 Ramp Enabled	<input type="checkbox"/> = When disabled, the G8600 will never attempt to ramp loads when there is a G0123 in use. <input checked="" type="checkbox"/> = When enabled, the G8600 will attempt to ramp loads when there is a G0123 in use.
G0123 Frequency Trip	(Only available if the G0123 Ramp option is enabled) If the frequency changes by this amount when ramping down, the module will open the generator breaker to avoid the frequency ramping to the point where an alarm trips.

3.7.9.4.2 LOAD CONTROL (SINGLE SET)

**Load Options**

Load Control Mode kW Control ▼

Reactive Load Control Mode kVAr Control ▼

Parameter	Description
Load Control Mode IEEE C37.2 -90 Regulating device	<p><b>kW Control:</b> The module synchronises the generator to the mains and controls the kW by forcing it to a pre-determined value.</p> <p><b>None:</b> The module synchronises the generator to the mains but once in parallel, does not actively control the amount of kW's This is left to external 3<sup>rd</sup> party devices such as an external kW controller or droop configured on the engine controller.</p>
Reactive Load Control Mode	<div style="border: 3px double black; padding: 5px; margin-bottom: 10px;"> <p><b>⚠ NOTE: Reactive Load Control Mode is forced to None when Load Control Mode set to None.</b></p> </div> <p><b>kvar Control:</b> The module synchronises the generator to the mains and controls the kvar by forcing it to a pre-determined value.</p> <p><b>None:</b> The module synchronises the generator to the mains but once in parallel, does not actively control the amount of kvar's. This is left to external 3<sup>rd</sup> party devices such as an external kvar controller or droop configured on the alternator AVR.</p>

**Load Share Ramp**

**Load Share Ramp**

Ramp Up Rate  % %/s

Ramp Down Rate  % %/s

Maximum Time to Ramp Down

Parameter	Description
Ramp Up Rate	<p><b>▲ NOTE:</b> The set initially takes load at the level set by the <i>Minimum Load Level</i> and then increases its load at this rate until the generated power is equal to the setting for <i>Load Parallel Power</i>.</p>
Ramp Down Rate	<p><b>▲ NOTE:</b> When the set is unloaded, it ramps down at this rate from the current load level to the level set by the <i>Minimum Load Level</i> before being removed from the bus.</p>
Maximum Time to Ramp Down	<p>This is to set a time limit to the ramp down process, and it is useful when the engine response is slow or is not capable to ramp off the load.</p> <p>The <i>Ramp Off Load</i> timer starts when the generator begins to ramp down. When this timer is expired the breaker opens regardless of the actual power.</p> <p>It is possible to set the ramp rate slower than this time, so the breaker opens prior to the ramp finishes.</p>

### 3.7.9.4.3 LOAD DEMAND (MULTI SET)

#### New Load Demand Scheme

**NOTE:** The G8600 software AMSC is not compatible with MSC. For more information contact DSE Technical Support [support@deepseaelectronics.com](mailto:support@deepseaelectronics.com)

The module is included in the *Load Demand Scheme* by activating a digital input configured as *Remote Start On Load Demand (Multi-Set)*. Every *Multi Set* module connected on the AMSC link which is required to run in the *Load Demand Scheme* must have a digital input configured for *Remote Start On Load Demand (Multi-Set)* and be active. Having this input on each *Multi Set* module enables a specific generator to be taken out of the *Load Demand Scheme* for service for maintenance (by de-activating the input) whilst allowing the remainder of the system to operate.

Upon activation of the *Remote Start On Load Demand (Multi-Set)* input, all the generators in the system start only if 'Starting Option' is set to *Start all sets initially*. The first generator to become available closes onto the dead bus, communicating with the other generators to instruct them to synchronise onto the now live bus, before closing in parallel. If too much generator capacity is available to supply the load, the generators that are not required begin their *Return Delay* timers, after which they will ramp off the bus and stop.

Whilst one or more generators are already available in *Load Demand Scheme*, it may be required to make all the generators in the system available to provide power to the load. For instance, this may be necessary prior to switching on a large load that the currently available generators are not able to supply. To provide this function, a digital input on each *Multi Set* module in the system must be configured to activate the *Remote start on load* input. Activating this input causes *Multi Set* module to start its generator, synchronise with the bus, and close in parallel.

The generators continue to provide power until the *Remote Start On Load Demand (Multi-Set)* input is de-activated. Providing the *Remote Start On Load Demand (Multi-Set)* input is still active on all the *Multi Set* modules, the *Load Demand Scheme* ramps the un-required generators off the bus, depending upon the total load level.

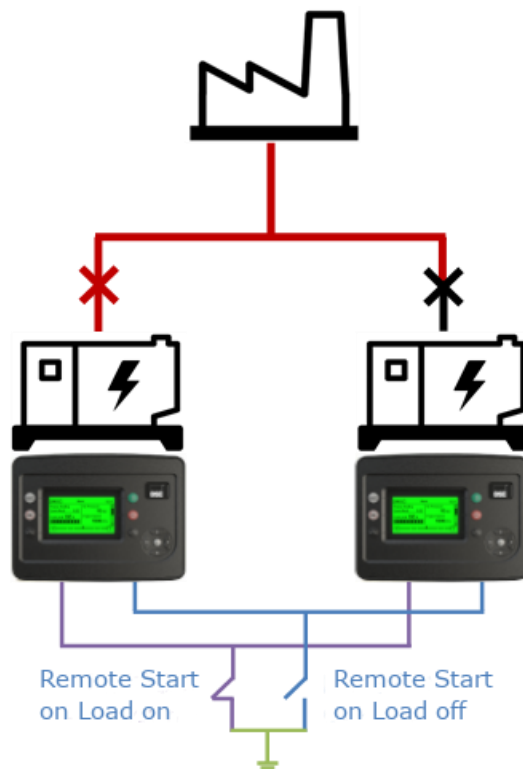

**NOTE:** Calling For More /Less sets is calculated based on the next Set to start or stop on the bus not the current set reaching a value and calling for the next one to start or stop.

Parameter	Description
Starting Options	<p>Determines how the load demand scheme operates upon start-up.</p> <p><b>Continuous Running, Load all Initially:</b> Upon activation of the load demand scheme, all sets in the system start up and parallel onto the generator bus. As load demands, sets go off load / on load. The set continues to run regardless of load levels until requested to stop.</p> <p><b>Continuous Running, Load as Required:</b> Upon activation of the load demand scheme, all sets start, and one set will go on load. Other sets in the system are only started according to demand. As load demands, sets become off load / on load. The set continues to run regardless of load levels until requested to stop.</p> <p><b>Disabled:</b> The Load Demand Scheme is disabled so no sets will start.</p> <p><b>Start all sets initially:</b> Upon activation of the load demand scheme, all sets in the system start up and parallel onto the generator bus. As load demands sets start / stop. This option is particularly recommended in Multiset Mains standby applications where the load is likely to be greater than the capacity of a single set.</p> <p><b>Start sets as load requires:</b> Upon activation of the load demand scheme, only one set will start initially. Other sets in the system are only started according to demand. This option is recommended for mutual standby systems where the load is likely to be less than the capacity of a single set.</p>
Load/Start Next Set on Warning	<p><b>NOTE:</b> Enabling <b>Start Next Set on Warning</b> results in the <b>All Warnings are Latched</b> option being forced on.</p> <p>Whenever a warning occurs, a start/load command is issued over the AMSC link to start the next highest priority set. The set with the warning stops once the next highest priority set has joined the bus and will not restart.</p>

Parameter descriptions are continued overleaf...

Parameter	Description
Allow Set to Start with Warning	<p><input type="checkbox"/> = A stationary set with a warning alarm active will not be considered part of the load demand scheme and so will not be called on to start.</p> <p><input checked="" type="checkbox"/> = A stationary set with a warning alarm active will be considered part of the load demand scheme and may be called on to start if the load requires it.</p>
Balance Engine Hours	<p>Used in a <i>Multi Set</i> system so that the engine's priority changes according to the amount of usage of the set.</p> <p>For instance, in a two-set system.</p> <p>Set 1 has logged 100 running hours Set 2 has logged 20 running hours Balance engine hours are configured to 75 hours.</p> <p>As Set 2 has logged 80 hours less than Set 1. As this is greater than the configured 75 hours, Set 2 is the highest priority set.</p> <p>If all sets are within the configured Balance Engine Hours value, the set with the minimum hours is started.</p>
Load Demand Scheme Delay	<p>The time for sets joining the bus (when the scheme is started) before they will leave for the <i>Start all sets initially</i> option.</p>
Calling For Less Sets	<p>The average bus percentage level at which the module decides that generator is disconnected from the generator bus. The generator does not disconnect from the bus when its percentage of kW is below the <i>Calling For Less Sets</i> value. Instead, the generator disconnects from the bus when it ensures that the remaining generators' kW percentage is at the <i>Calling For Less Sets</i> value when it disconnects. This prevents the system from reaching a point where the load is such that the generator starts and stops repeatedly.</p> <p>Once the load is below this level, the lowest priority generator in the sequence (determined using the <i>Genset Priority</i>) begins its <i>Return Delay</i> timer. Once this has expired, the generator ramps off and stops.</p> <p>If the load level rises above this set point during the <i>Return Delay</i> timer, the timer is cancelled, and the generator continues to supply power to the load. This caters for short term reductions in kW load demand.</p>
Calling For More Sets	<p>The kW load level at which the module calls for additional generators to join the generator bus.</p> <p>Once the load is above this level, the highest priority generator that is not running in the sequence (determined using the <i>Genset Priority</i>) begins its <i>Start Delay</i> timer. Once this has expired, the generator joins the bus and ramps up.</p> <p>If the load level reduces below this set point during the <i>Start Delay</i> timer, the timer is cancelled, and the generator enters its stops cycle. This caters for short term kW load demand.</p> <p>If the set fails to become available, it communicates this using the AMSC Link which signals the next generator in the sequence to take its place.</p>
Start Delay	<p>Time delay used at start up to ensure the start request is not simply a fleeting request. This timer is only active in the Load Demand Scheme.</p>
Return Delay	<p>Time delay used for generators to ramp of the bus. This timer is only active in the Load Demand Scheme.</p>

**Spinning Capacity**

Parameter	Description
Enable	<input type="checkbox"/> = <i>Spinning capacity</i> is disabled. <input checked="" type="checkbox"/> = <i>Spinning capacity</i> is enabled.
Spinning Capacity	The minimum power that will be available on the bus. The Load Demand Scheme will always run enough sets to exceed this value regardless of load and calling for less sets setting.
Not Reached Alarm	An alarm is generated when the spinning capacity cannot be achieved.
Action	Select the action for the <i>Not Reached Alarm</i> : <b>Indication:</b> <b>Warning:</b>
Delay	Set the amount of time before the <i>Spinning Capacity Alarm</i> activates.

**Spinning Reserve**

Parameter	Description
Enable	<input type="checkbox"/> = <i>Spinning reserve</i> is disabled. <input checked="" type="checkbox"/> = <i>Spinning reserve</i> is enabled.
Spinning Reserve	The power available over and above the load requirements on the bus. The load demand scheme will start further sets to ensure that sufficient power is available above the load requirements of the bus and will ensure this margin is maintained.
Not Reached Alarms	Activates when the spinning reserve cannot be achieved.
Action	Select the action for the <i>Not Reached Alarm</i> : <b>Indication:</b> <b>Warning:</b>
Delay	Set the amount of time before the <i>Spinning Reserve Alarm</i> activates.

### 3.7.9.4.4 CREATING / EDITING THE DROOP CURVES

While the *DSE Configuration Suite* holds the most used droop curves, occasionally it is required that the module's droop function be configured for a specification application not listed by the *DSE Configuration Suite*. To aid this process, a droop curve editor is provided.

The screenshot shows the 'Load Options' configuration window. It has two sections for 'Load Control Mode' and 'Reactive Load Control Mode', both set to 'Droop'. The 'Control Curve' dropdown is set to 'Test21', and a context menu is open showing 'Built In' (3.33% Droop: 2.5% Nominal Offset) and 'User Defined' (4.73% Droop: -33%, 3.6% Offset). The 'Ramp Rate' is set to 0.1%. Callouts include: 'Select a Built-in curve.', 'Any saved curves become selectable in the User Defined selection list.', and 'Click to edit the droop curve or create a curve if a curve is not selected.'

#### Example

The screenshot shows the 'Curve Editor' window with a graph titled 'Voltage Droop Based on kVAr % of Total Load'. The Y-axis is '% of nominal voltage' (90-110) and the X-axis is 'kVAr Full Load (%)' (-40-100). A blue line connects two points. Callouts include: 'Click and drag the points on the graphs to change the settings', 'Double click the left mouse button to add a point or right click on a point to remove it.', 'Click to change the range of the X and Y Axes of the graph.', 'Use the mouse to select the graph point, then enter the value in the box or click up/down to change the value', 'Click SAVE As prompt to name the curve... Click OK to save', and 'Click Interpolate then select two points as prompted to draw a straight line between them.' The bottom of the window has buttons for 'Interpolate', 'Change Axes Range', 'Save As', 'OK', and 'Cancel'.

**Change Axis Range**

**NOTE:** The difference between the Minimum and Maximum values on the X and Y axis must exceed the noted limits.

Select Range

kW Full Load (%)	% of nominal frequency
0	102
100	99

The X Axis is a % of kW Full Load.

The Y Axis is a % of nominal frequency.

Axis	Minimum	Maximum
X-Axis(%)	0	100
Y-Axis(%)	90	110

X-Axis range must exceed 100 %

Y-Axis range must exceed 2 %

OK Cancel

### 3.7.9.5 SET DRIVE PROTECTION

#### Insufficient Capacity

The screenshot shows a configuration window titled "Insufficient Capacity". It contains two main settings: "Action" is set to "None" via a dropdown menu, and "Delay" is set to "1s" with a corresponding slider control.

Parameter	Description
Action	<p>Activates when the governor output percentage reaches the maximum value for the configured <i>Delay</i> time. This indicates that the generator is not able to produce the kW requested due to having incorrect settings for SW1 and SW2 or a fault with the engine. For further information see the section entitled <i>Alarm Types</i> elsewhere in this document.</p> <p>The alarm action list is as follows:</p> <p><b>Electrical Trip:</b>  <b>Indication:</b>  <b>None:</b>  <b>Shutdown:</b>  <b>Warning:</b></p>
Delay	Set the amount of time before the <i>Alarm</i> activates.

**AVR Loss of Excitation**

The screenshot shows the 'AVR Loss Of Excitation' configuration window. It includes the following settings:

- Arming:** Active from Mains Parallel (Single Set)
- Pre-Alarm:**
- Trip:** 25.0 %
- Return:** 20.0 %
- Alarm:**
- Action:** Shutdown
- Trip:** 35.0 %
- Delay:** 1s

Parameter	Description
Arming	<p><b>NOTE:</b> For details of these, see the section 6 entitled <i>Alarm Arming</i> for more information.</p> <p>Select when the <i>Loss Of Excitation</i> alarm becomes active:  <b>Active from Mains Parallel</b>  <b>Always</b></p>
Loss Of Excitation Pre-Alarm IEEE C37.2 – 32 Directional Power Relay	<p><input type="checkbox"/> = <i>Loss of Excitation</i> does NOT give a pre-alarm warning</p> <p><input checked="" type="checkbox"/> = The <i>Loss of Excitation Pre-Alarm</i> is active when the measured negative kvar exceeds the <i>Loss of Excitation Pre-Alarm Trip</i> setting. The <i>Loss of Excitation Pre-Alarm</i> is automatically reset when the measured negative kvar no longer exceeds the configured <i>Loss of Excitation Pre-Alarm Return</i> level. The <i>Loss Of Excitation Trip</i> level is adjusted to suit user requirements.</p>
Loss Of Excitation Alarm IEEE C37.2 – 32 Directional Power Relay	<p><input type="checkbox"/> = Loss of excitation does NOT give a Shutdown alarm</p> <p><input checked="" type="checkbox"/> = The <i>Loss of Excitation Alarm</i> is active when the measured negative kvar exceeds the <i>Loss of Excitation Alarm</i> setting for the configured <i>Delay</i>. The <i>Loss Of Excitation Trip</i> level and action is adjusted to suit user requirements.</p>
Action	<p><b>NOTE:</b> For details of these, see the section entitled <i>Alarm Types</i> elsewhere in this document.</p> <p>Select the type of alarm required from the list:  <b>Electrical Trip:</b> The breaker is opened immediately, and the cooling timer begins, after which the set is stopped.  <b>Shutdown:</b> The breaker is opened immediately, and the set is immediately stopped.</p>
Delay	Set the amount of time before the <i>Alarm</i> activates.

**AVR Trim Alarm**

Parameter	Description
AVR Trim Alarm	<p>Activates when the AVR output percentage reaches the maximum value for the configured <i>Delay</i> time. This indicates that the generator is not able to produce the kvar requested due to having incorrect settings for SW1 and SW2, or a fault with the alternator. The alarm action list is as follows, see section 5 entitled <i>Alarm Types</i> for more information:</p> <p><b>Electrical Trip:</b>  <b>Indication:</b>  <b>None:</b>  <b>Shutdown:</b>  <b>Warning:</b></p>
Delay	Set the amount of time before the <i>Alarm</i> activates.

### 3.7.9.6 POWER CONTROL

**NOTE:** The *Power Control* modes and *Voltage and Reactive Power Control* modes are to be used in conjunction with the following documents:

- VDE-AR-N 4110:2018-04 defines the technical requirements for connecting and operating generation and storage systems on the medium-voltage grid in Germany.
- Engineering Recommendation G99 Issue 2 – Amendment 8 10th March 2025
- COMMISSION REGULATION (EU) 2016/631 of 14 April 2016 establishing a network code on requirements for grid connection of generators
- P1547 - IEEE Draft Standard for Interconnection and Interoperability of Distributed Energy Resources with Associated Electric Power Systems Interfaces

**NOTE:** The *Simulation Injection Testing* tool of the DSE Configuration Suite PC Software allows testing the generator's frequency response and check its performance for the *Power Control* curves. For details on how to test the *Simulation Injection* on the DSE module refer to DSE Publication: 056-123 Simulation Injection Testing document.

**NOTE:** The *Power Control* parameters (Multi Set Mode Selected) only have effect when a digital input is configured for *Mains Parallel Mode* instructing the module to operate in fixed export mode with the utility supply. In Single Set Mode this operation is done automatically. For more information on this application, refer to DSE Publication: 056-054 DSE8x10 in Fixed Export (Base Load) which is found on our website: [www.deepseaelectronics.com](http://www.deepseaelectronics.com)

**NOTE:** Activation of the different Power Control modes is done through digital inputs, PLC functions, Front Panel Editor or Modbus; with digital inputs having higher priority over PLC functions, and PLC functions have higher priority over Front Panel Editor and Modbus commands.

**NOTE:** Simultaneously activating different *Power Control* modes, results in the lowest number taking priority.

#### **Constant Power Mode (Default)**

Constant Power Mode (Default)  
No additional settings are required

This is the default mode of exporting power to the Mains (utility); where the DSE load share controller holds the amount of power produced at a constant level. The amount of power produced by the generator is irrespective of the load level or any other parameter.

The amount of power produced is defined as Maximum kW Level and is set in SCADA | Generator | Load Levels section, through the Front Panel Running Editor, in PLC Functions, or via Modbus messages.

**Frequency-Power Mode**

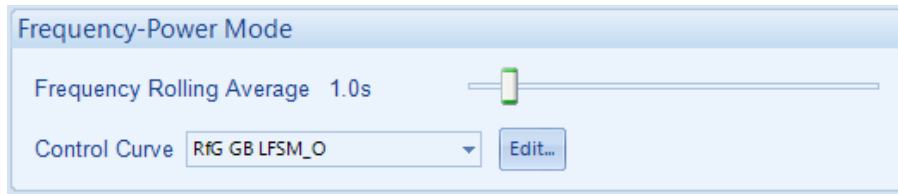

In this mode of exporting power to the Mains (utility); the DSE load share controller varies the amount of power produced with regards to the Control Curve depending on the measured frequency. This mode allows the generator to support the Mains (utility) frequency stability by monitoring the frequency and changing the amount of power produced.

Parameter	Description
Frequency Rolling Average	The measured frequency is averaged over the period of the <i>Frequency Rolling Average</i> . The average frequency is used in the <i>Control Curve</i> to determine the required level of power production.
Control Curve	<p>The <i>Control Curve</i> determines, based on the average frequency, the amount of power the generator produces. This amount of power is a percentage of the <i>kW Maximum Load Level</i> set within the SCADA section.</p> <p>Select the <i>Control Curve</i> from a pre-defined list or create a user-defined curve.</p> <p><b>RfG GB LFSM_O</b>: Requirements for Generators Network Code in Great Britain, Limited Frequency Sensitive Mode Over frequency.</p> <p><b>RfG GB LFSM_U</b>: Requirements for Generators Network Code in Great Britain, Limited Frequency Sensitive Mode Under frequency.</p> <p><b>RfG GB LFSM_U and LFSM_O</b>: Requirements for Generators Network Code in Great Britain, Limited Frequency Sensitive Mode Under frequency and Over frequency.</p> <p><b>RfG GB FSM 5%</b>: Requirements for Generators Network Code in Great Britain, Frequency Sensitive Mode at 5 %.</p> <p><b>P1547 60Hz 50%</b>: Requirements for Generators in United States, Frequency Sensitive Mode at 50%.</p> <p><b>P1547 60Hz 75%</b>: Requirements for Generators in United States, Frequency Sensitive Mode at 75 %.</p> <p><b>P1547 60Hz 90%</b>: Requirements for Generators in United States, Frequency Sensitive Mode at 90 %.</p> <p><b>VDE4110 5%</b>- Requirements for Generators in Germany, Frequency Sensitive Mode at 5 %.</p>

**Voltage-Power Mode**



In this mode of exporting power to the Mains (utility); the DSE load share controller varies the amount of power produced with regards to the Control Curve depending on the measured voltage. This mode allows the generator to support the Mains (utility) voltage stability by monitoring the voltage and changing the amount of power produced.

Parameter	Description
Voltage Rolling Average	The measured voltage is averaged over the period of the <i>Voltage Rolling Average</i> . The average voltage is used in the <i>Control Curve</i> to determine the required level of power production.
Control Curve	The <i>Control Curve</i> determines, based on the average voltage, the amount of power the generator produces. This amount of power is a percentage of the <i>kW Maximum Load Level</i> .  Select the <i>Control Curve</i> from a pre-defined list or create a user-defined curve.

**Power Ramp on Setpoint Change**

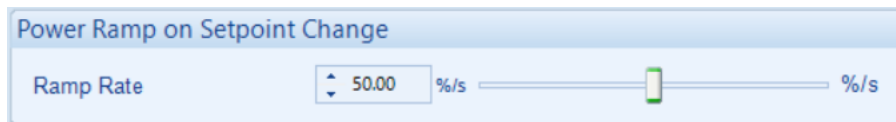

Parameter	Description
Ramp Rate	When changing between <i>Power Control</i> modes or changing the set point, the <i>Ramp Rate</i> defines how fast the output power changes in percentage points per second.

### 3.7.9.6.1 CREATING / EDITING THE POWER MODE CURVE

While the *DSE Configuration Suite* holds the most used droop curves, occasionally it is required that the module's droop function be configured for a specification application not listed by the *DSE Configuration Suite*. To aid this process, a droop curve editor is provided.

The droop curve that is to be used or edited.

Click to edit the droop curve or create a curve if a curve is not selected.

Click and drag the points on the graphs to change the settings

Use the mouse to select the graph point, then enter the value in the box or click up/down to change the value

Double click the left mouse button to add a point or right click on a point to remove it.

Click *Interpolate* then select two points as prompted to draw a straight line between

Click to change the range of the X and Y Axes of the graph and the level of open circuit

Click *Save As* prompt to name the curve...

Click OK to accept the changes or CANCEL to ignore and lose the changes.

Click OK to save the curve.

Any saved curves become selectable in the *Input Type* selection list.

**Hint:** Deleting, renaming, or editing custom power curves that have been added is performed in the main menu, select *Tools | Curve Manager*.

### 3.7.9.7 VDE POWER CONTROL

#### Frequency Power Mode

**NOTE:** The *Critical Frequency Return Time* should be set to at least 10 minutes.

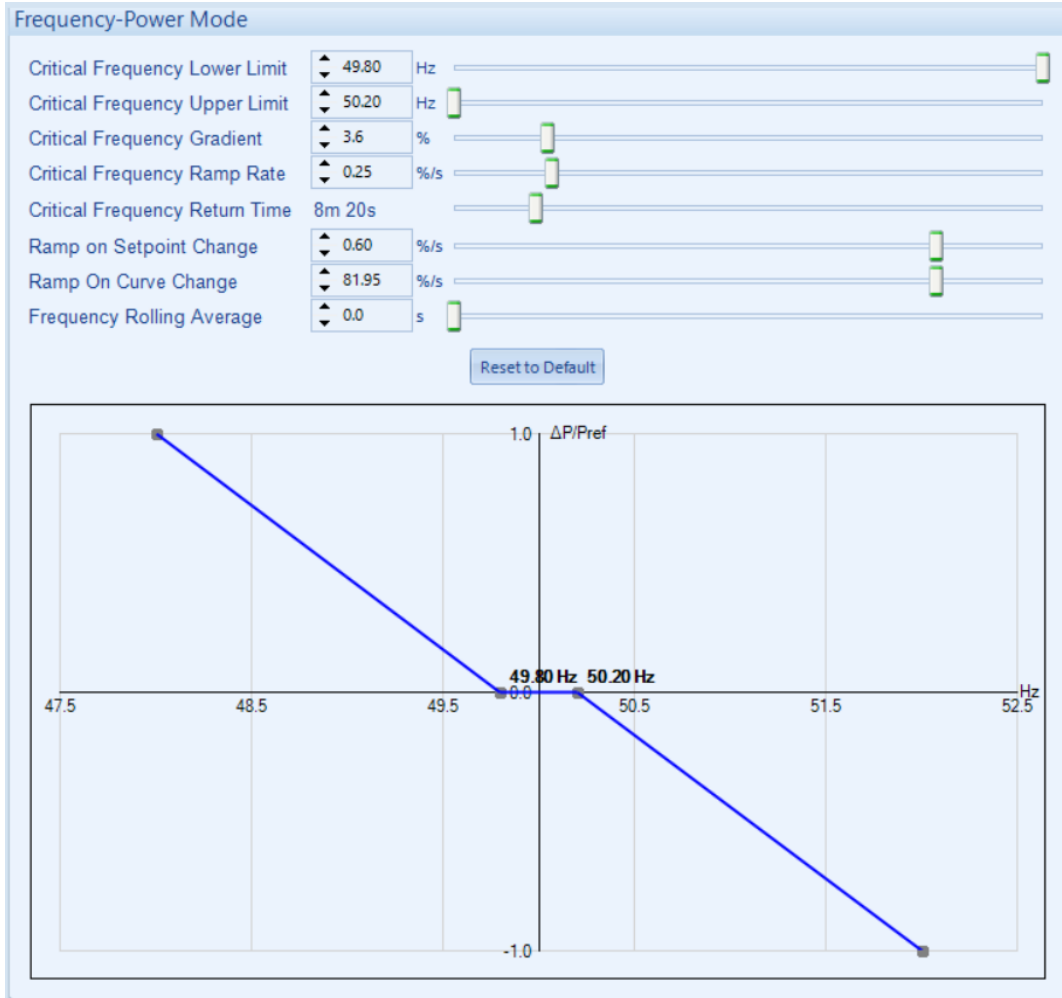

Parameter	Description
Critical Frequency Lower Limit	When the grid frequency falls below this level it enters a critical region, the power set point of the generator will be frozen, but frequency control will continue to follow the curve. It should be set to 49.80Hz to be VDE compliant.
Critical Frequency Upper Limit	When the grid frequency rises above this level it enters a critical region, the power set point of the generator will be frozen, but frequency control will continue to follow the curve. It should be set to 50.20Hz to be VDE compliant.
Critical Frequency Gradient	The gradient of the frequency-power curve. It should be set to 5% to be VDE compliant.
Critical Frequency Ramp Rate	When the grid frequency returns within the limits, but the return timer is still counting, the power set point can only be changed at this reduced rate. It should be set to 0.16%/s to be VDE compliant.

Parameters continued overleaf...

*Editing the Configuration*

<b>Parameter</b>	<b>Description</b>
Critical Frequency Return Time	When the grid frequency returns from either critical region to be between the upper and lower limits, the grid is still considered to be in a critical state for the duration of this return time. It should be set to 10m to be VDE compliant.
Ramp On Setpoint Change	When the grid frequency has been within the limits for the duration of the return timer, the power set point can be changed at this rate. It should be set to 0.66%/s to be VDE compliant.
Ramp On Curve Change	When the grid frequency moves up and down the curve, the resulting power can change at this rate. This rate is not defined by VDE and is 100%/s by default, it can be reduced when needed to maintain generator stability.
Frequency Rolling Average	The grid frequency measurement is rolling averaged over this period to reduce reading fluctuations, when necessary, set to zeros by default.

### 3.7.9.8 VOLTAGE AND REACTIVE POWER CONTROL

 **NOTE:** The *Power Control* modes and *Voltage and Reactive Power Control* modes are to be used in conjunction with the following documents:

- VDE-AR-N 4110:2018-04 defines the technical requirements for connecting and operating generation and storage systems on the medium-voltage grid in Germany.
- Engineering Recommendation G99 Issue 1 – Amendment 8 10th March 2025
- COMMISSION REGULATION (EU) 2016/631 of 14 April 2016 establishing a network code on requirements for grid connection of generators
- P1547 - IEEE Draft Standard for Interconnection and Interoperability of Distributed Energy Resources with Associated Electric Power Systems Interfaces

 **NOTE:** The *Simulation Injection Testing* tool of the DSE Configuration Suite PC Software allows testing the generator's voltage response and check its performance for the *Voltage & Reactive Power Control* curves. For details on how to test the *Simulation Injection* on the DSE module refer to DSE Publication: 056-123 Simulation Injection Testing document.

 **NOTE:** The *Voltage and Reactive Power Control* parameters only have effect when a digital input is configured for *Multi Set Mode* instructing the module to operate in fixed export mode with the utility supply. In *Single Set Mode* this operation is done automatically. For more information on this application, refer to DSE Publication: 056-054 DSE8x10 in Fixed Export (*Base Load*) which is found on our website: [www.deepseaelectronics.com](http://www.deepseaelectronics.com)

 **NOTE:** Activation of the different *Voltage and Reactive Power Control* modes is done through digital inputs, PLC functions, Front Panel Editor or Modbus; with digital inputs having higher priority over PLC functions, and PLC functions have higher priority over Front Panel Editor and Modbus commands.

 **NOTE:** Simultaneously activating different *Voltage and Reactive Power Control* modes, results in the lowest number taking priority.

**Constant Power Factor Mode**

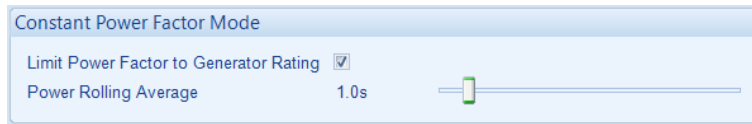

In this mode of exporting power to the Mains (utility); the DSE load share controller varies the amount of reactive power produced with regards to maintaining the required power factor. This mode allows the generator to maintain a constant export power factor if so required. The required power factor is set in *SCADA | Generator | Load Levels* section, through the Front Panel Running Editor, PLC Functions, or Modbus messages.

Parameter	Description
Limit Power Factor to Generator Rating	<p><input type="checkbox"/> = The generator produces power beyond its specified power factor rating configured within the <i>Generator Rating</i> section. This may lead to the generator producing excessive positive or negative kvar.</p> <p><input checked="" type="checkbox"/> = The generator produces power within its specified power factor rating configured within the <i>Generator Rating</i> section.</p>
Power Rolling Average	The exported power is averaged over the period of the <i>Power Rolling Average</i> . The average power is then used to determine the required reactive power production to achieve the set power factor.

**Voltage-Reactive Power Mode**

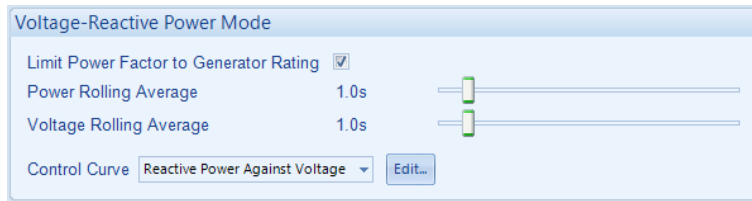

In this mode of exporting power to the Mains (utility); the DSE load share controller varies the amount of reactive power produced with regards to the Control Curve depending on the measured voltage. This mode allows the generator(s) to support the Mains (utility) voltage stability by monitoring the voltage and changing the amount of reactive power produced.

Parameter	Description
Limit Power Factor to Generator Rating	<input type="checkbox"/> = The generator produces power beyond its specified power factor rating configured within the <i>Generator Rating</i> section. This may lead to the generator producing excessive positive or negative kvar. <input checked="" type="checkbox"/> = The generator produces power within its specified power factor rating configured within the <i>Generator Rating</i> section.
Power Rolling Average	The exported power is averaged over the period of the <i>Power Rolling Average</i> . The average power is used to calculate the power factor if the option <i>Limit Power Factor To Generator Rating</i> is enabled.
Voltage Rolling Average	The measured voltage is averaged over the period of the <i>Voltage Rolling Average</i> . The average voltage is used in the <i>Control Curve</i> to determine the required level of reactive power production.
Control Curve	The <i>Control Curve</i> determines, based on the average voltage, the amount of reactive power the generator produces. This amount of power is a percentage of the <i>kvar Maximum Load Level</i> .  Select the <i>Control Curve</i> from a pre-defined list or create a user-defined curve.

**Power-Power Factor Mode**

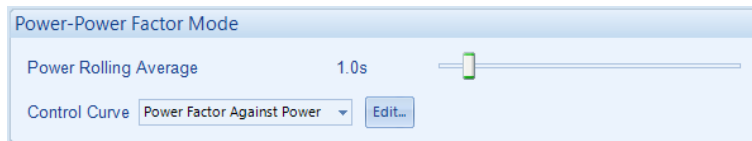

In this mode of exporting power to the Mains (utility); the DSE load share controller varies the amount of reactive power produced with regards to maintaining the required power factor. This power factor is derived from the averaged power using the *Control Curve*. This mode allows the generator to support the Mains (utility) stability by varying the power factor depending on the export power.

Parameter	Description
Power Rolling Average	The exported power is averaged over the period of the <i>Power Rolling Average</i> . The average is then used in the <i>Control Curve</i> to determine the required power factor.
Control Curve	The <i>Control Curve</i> determines, based on the average power, the power factor that is required.  Select the <i>Control Curve</i> from a pre-defined list or create a user-defined curve.

**Constant Reactive Power Mode (Default)**

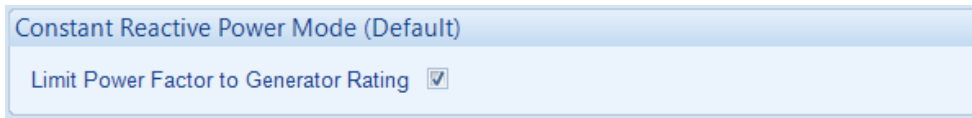

This is the default mode of exporting power to the Mains (utility); where the DSE load share controller holds the amount of reactive power produced at a constant level. The amount of reactive power produced by the generator is irrespective of the load level or any other parameter. The amount of reactive power produced is defined as *Maximum kvar Level* and is set in SCADA/Generator/Load Levels section, through the Front Panel Running Editor, in PLC Functions, or via Modbus messages.

Parameter	Description
Limit Power Factor to Generator Rating	<input type="checkbox"/> = The generator produces kvars beyond its specified power factor rating configured within the <i>Generator Rating</i> section. This may lead to the generator producing excessive positive or negative kvar. <input checked="" type="checkbox"/> = The generator produces kvars within its specified power factor rating configured within the <i>Generator Rating</i> section.

**Power-Reactive Power Mode**

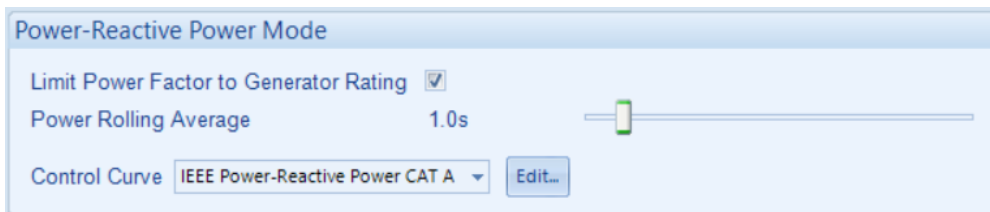

Parameter	Description
Limit Power Factor to Generator Rating	<input type="checkbox"/> = The generator produces power beyond its specified power factor rating configured within the <i>Generator Rating</i> section. This may lead to the generator producing excessive positive or negative kvar. <input checked="" type="checkbox"/> = The generator produces power within its specified power factor rating configured within the <i>Generator Rating</i> section.
Power Rolling Average	The exported power is averaged over the period of the <i>Power Rolling Average</i> . The average is then used in the <i>Control Curve</i> to determine the required power factor.
Control Curve	The <i>Control Curve</i> determines, based on the average power, the power factor that is required.  Select the <i>Control Curve</i> from a pre-defined list or create a user-defined curve.

**Reactive Power Ramp on Setpoint Change**

Reactive Power Ramp on Setpoint Change

Ramp Type: Linear

Ramp Rate: 50.00 %/s

Time for 3 Tau: 6.0 s

Parameter	Description
Ramp Type	Select the Ramp type from the list:  <b>Linear</b> -Select for a linear curve <b>PT1</b> - Select for a logarithmic curve
Ramp Rate	When changing between <i>Voltage and Reactive Power Control</i> modes or changing the set point, the <i>Ramp Rate</i> defines how fast the output reactive power changes in percentage points per second.
Time for 3 Tau	This option is enabled when the <i>Ramp Type</i> is set to PT1. This is used as a time constant for reactive power (var) control.

### 3.7.9.9 VDE VOLTAGE AND REACTIVE POWER CONTROL

#### VDE Voltage-Reactive Power Mode

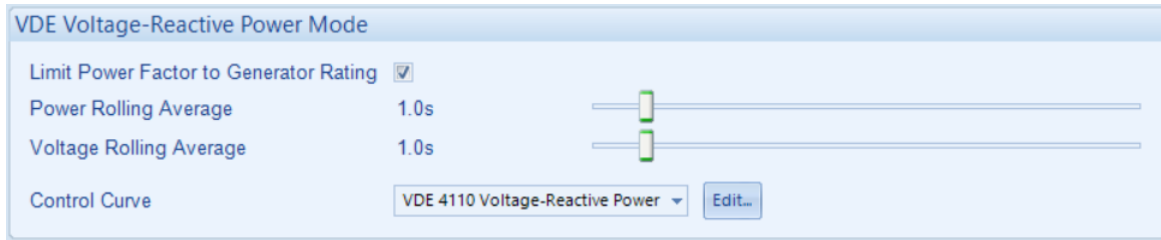

In this mode of exporting power to the Mains (utility); the DSE load share controller varies the amount of reactive power produced with regards to the Control Curve depending on the measured voltage. This mode allows the generator(s) to support the Mains (utility) voltage stability by monitoring the voltage and changing the amount of reactive power produced.

Parameter	Description
Limit Power Factor to Generator Rating	<input type="checkbox"/> = The generator produces power beyond its specified power factor rating configured within the <i>Generator Rating</i> section. This may lead to the generator producing excessive positive or negative kvar. <input checked="" type="checkbox"/> = The generator produces power within its specified power factor rating configured within the <i>Generator Rating</i> section.
Power Rolling Average	The exported power is averaged over the period of the <i>Power Rolling Average</i> . The average power is used to calculate the power factor if the option <i>Limit Power Factor To Generator Rating</i> is enabled.
Voltage Rolling Average	The measured voltage is averaged over the period of the <i>Voltage Rolling Average</i> . The average voltage is used in the <i>Control Curve</i> to determine the required level of reactive power production.
Control Curve	<div style="border: 2px solid black; padding: 5px;"> <p><b>⚠ NOTE: The VDE standard requires the Y axis of the graph to be defined as Q/Pbinst which is the ratio of reactive power to the generated power, e.g. 0.33 equals a power factor of 0.95.</b></p> </div> <p>The <i>Control Curve</i> determines, based on the average voltage, the amount of reactive power the generator produces. This amount of power is a percentage of the <i>kvar Maximum Load Level</i>. Select the <i>Control Curve</i> from a pre-defined list or create a user-defined curve.</p>

**VDE Power-Reactive Power Mode**

Parameter	Description
Limit Power Factor to Generator Rating	<input type="checkbox"/> = The generator produces power beyond its specified power factor rating configured within the <i>Generator Rating</i> section. This may lead to the generator producing excessive positive or negative kvar. <input checked="" type="checkbox"/> = The generator produces power within its specified power factor rating configured within the <i>Generator Rating</i> section.
Power Rolling Average	The exported power is averaged over the period of the <i>Power Rolling Average</i> . The average is then used in the <i>Control Curve</i> to determine the required power factor.
Control Curve	<p><b>⚠ NOTE: The VDE standard requires the Y axis of the graph to be defined as Q/Pbinst which is the ratio of reactive power to the generated power, e.g. 0.33 equals a power factor of 0.95.</b></p> <p>The <i>Control Curve</i> determines, based on the average power, the power factor that is required.                      Select the <i>Control Curve</i> from a pre-defined list or create a user-defined curve.</p>

**VDE Reactive Power Limited Mode**

Parameter	Description
Limit Power Factor to Generator Rating	<input type="checkbox"/> = The generator produces power beyond its specified power factor rating configured within the <i>Generator Rating</i> section. This may lead to the generator producing excessive positive or negative kvar. <input checked="" type="checkbox"/> = The generator produces power within its specified power factor rating configured within the <i>Generator Rating</i> section.
Power Rolling Average	The exported power is averaged over the period of the <i>Power Rolling Average</i> . The average power is used to calculate the power factor if the option <i>Limit Power Factor To Generator Rating</i> is enabled.
Voltage Rolling Average	The measured voltage is averaged over the period of the <i>Voltage Rolling Average</i> . The average voltage is used in the <i>Control Curve</i> to determine the required level of reactive power production.
Control Curve	<p><b>⚠ NOTE: The VDE standard requires the Y axis of the graph to be defined as Q/Pbinst which is the ratio of reactive power to the generated power, e.g. 0.33 equals a power factor of 0.95.</b></p> <p>The <i>Control Curve</i> determines, based on the average voltage, the amount of reactive power the generator produces.                      Select the <i>Control Curve</i> from a pre-defined list or create a user-defined curve.</p>

**VDE Displacement Factor cos  $\phi$  Mode**

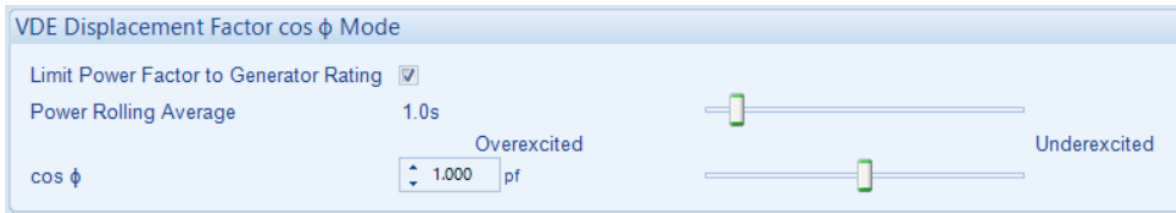

Parameter	Description
Limit Power Factor to Generator Rating	<input type="checkbox"/> = The generator produces power beyond its specified power factor rating configured within the <i>Generator Rating</i> section. This may lead to the generator producing excessive positive or negative kvar. <input checked="" type="checkbox"/> = The generator produces power within its specified power factor rating configured within the <i>Generator Rating</i> section.
Power Rolling Average	The exported power is averaged over the period of the Power Rolling Average. The average power is used to calculate the reactive power corresponding to the current power factor.
cos $\phi$	<div style="border: 2px solid black; padding: 5px;"> <p><b>⚠ NOTE: This parameter may be adjusted remotely. Refer to section entitled <i>VDE Levels in the SCADA</i> section elsewhere in this document.</b></p> </div> <p>The power factor required, note VDE defines Over Excited (lagging) power factors as being negative, the opposite of the convention used elsewhere in this module.</p>

**Telecontrol Link Failure**

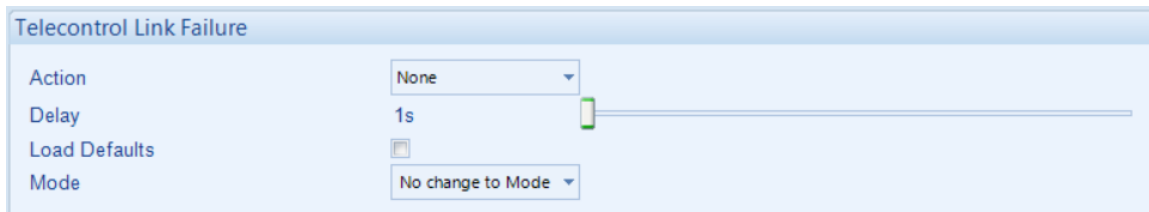

Parameter	Description
Action	Select the type of alarm required from the list: <b>None</b> <b>Electrical Trip</b> <b>Indication</b> <b>Shutdown</b> <b>Warning</b> For details of these, see the section 5 entitled <i>Alarm Types</i> for more information.
Delay	Set the amount of time before alarm is activated.
Load Defaults	<input type="checkbox"/> = The default VDE parameters defined in the configuration are not reset if the link fails. <input checked="" type="checkbox"/> = When checked, if the link fails the module will reset all remotely controlled VDE parameters to the values defined in the configuration. Power control parameters are not reset.

Parameter descriptions are continued overleaf...

Parameter	Description
Mode	<p>If the link fails, the module will switch to the specified reactive power control mode. Power control mode is not changed.                      Select the mode to switch to:</p> <ul style="list-style-type: none"> <li><b><i>No change to Mode</i></b></li> <li><b><i>Constant Power Factor Mode</i></b></li> <li><b><i>Voltage-Reactive Power Mode</i></b></li> <li><b><i>Power-Power Factor Mode</i></b></li> <li><b><i>Constant Reactive Power Mode</i></b></li> <li><b><i>Power-Reactive Power Mode</i></b></li> <li><b><i>VDE Voltage-Reactive Power Mode</i></b></li> <li><b><i>VDE Power-Reactive Power Mode</i></b></li> <li><b><i>VDE Reactive Power Limited Mode</i></b></li> <li><b><i>VDE Displacement Factor <math>\cos \phi</math> Mode</i></b></li> </ul>

### 3.7.9.9.1 CREATING/ EDITING THE VDE VOLTAGE AND REACTIVE POWER CURVE

Occasionally it may be necessary to adjust the VDE Voltage and Reactive power curves. To facilitate this process, a curve editor with limited functionality is available.

### 3.7.9.9.2 VDE VOLTAGE REACTIVE POWER CURVE

**NOTE:** These parameters may be adjusted remotely. Refer to section entitled *VDE Levels in the SCADA section elsewhere in this document.*

The screenshot shows the 'Curve Editor' window. The graph plots Q/PbInst (y-axis, ranging from -0.5 to 0.5) against U/Uc (x-axis, ranging from 0.90 to 1.10). A red curve represents the required target protection curve, and a dotted yellow curve represents the preset nominal voltage curve. Callouts explain: 'Leading vars.' (top left), 'Lagging vars.' (bottom left), 'Modifying the shape of this curve adjusts the shape of the target protection curve.' (center), 'Preset nominal voltage.' (center), 'Hysteresis.' (right), and 'Q/PbInst-Ratio of VARs to installed power.' (top right). Below the graph are input fields for UMax/Uc (1.020), QMax/PbInst (0.34), UQ0/Uc (1.020), and Dead Band (1.0 %). Buttons for 'Save As', 'OK', and 'Cancel' are also visible.

Use the mouse to select the graph point, then enter the value in the box or click up/down to change the value. Changing the values of UMax/Uc and QMax/PbInst adjusts the position of the red curve.

Changing the Dead Band value allows adjustment of the Hysteresis.

Click OK to accept the changes or *Cancel* to ignore and lose the changes. Click *Save As* to save the curve.

Parameter	Description
UMax/Uc	The voltage at which the maximum required reactive power will be generated, applies to both over and under excited as the curve is symmetrical.
QMax/Pbinst	The maximum required reactive power, applies to both over and under excited as the curve is symmetrical.
UQ0/UC	The offset of the control curve along the x axis, set remotely by the grid operator to define the operating voltage of the grid at the connection point. In operation the red curve will be positioned as shown by the dotted yellow curve but has to be shown referenced to 1.00 because of the definition of the other parameters.

Parameter descriptions are continued overleaf...

*Editing the Configuration*

<b>Parameter</b>	<b>Description</b>
Dead Band	<p>The dead band represents a range of voltage levels within which the control system does not take any corrective action. This means that minor fluctuations in voltage within this band are tolerated without triggering a response.</p> <p>The options are: <b>Hysteresis</b>- Allows adjustment of the Hysteresis loop. <b>Step</b>- Allows adjustment of the Hysteresis step.</p>

### Explanation of Hysteresis

Hysteresis in this context refers to the lagging behaviour of reactive power values as voltage changes. Here's a detailed explanation:

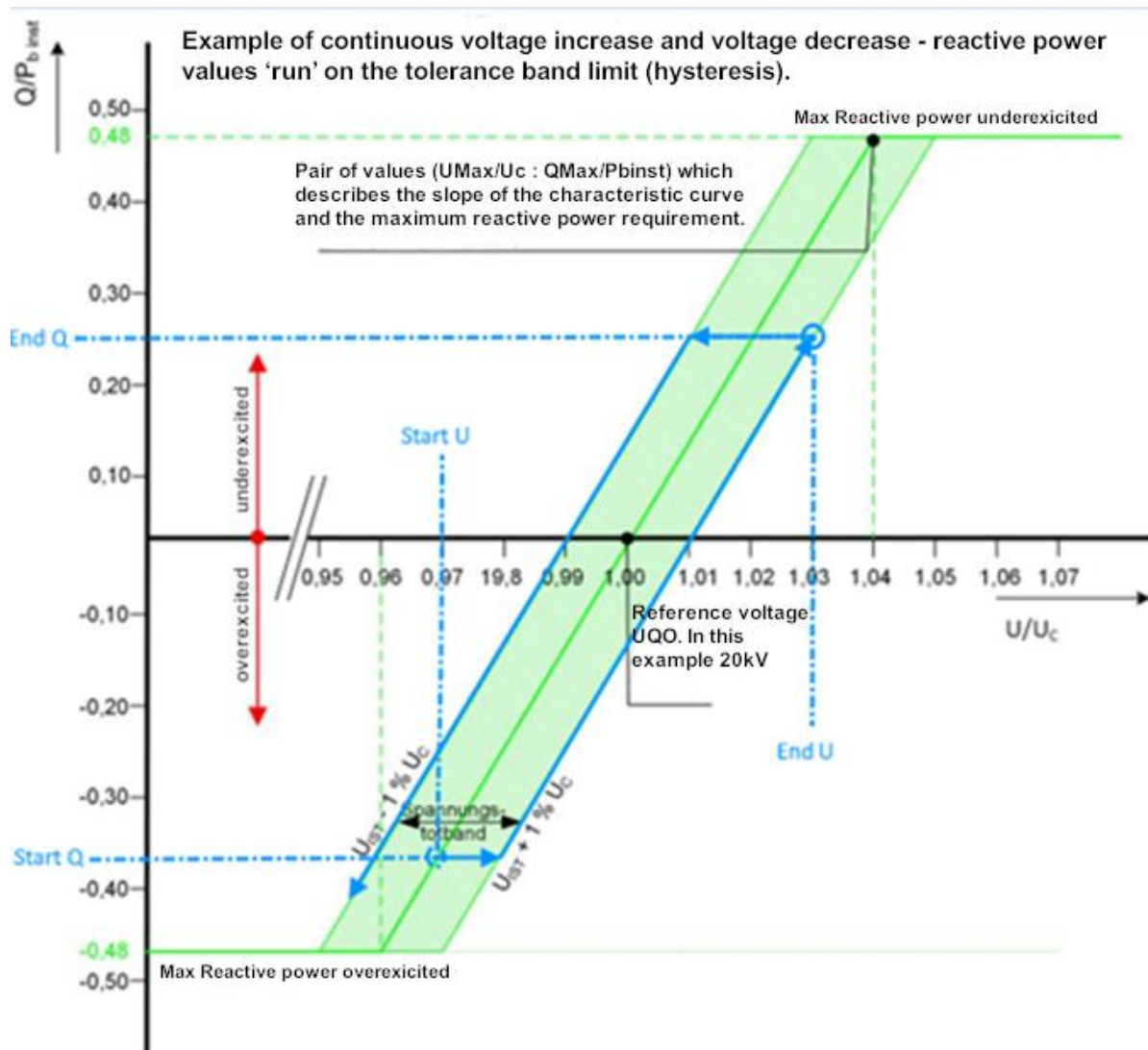

1. **Path Dependence:** The reactive power ( $Q$ ) does not immediately follow the changes in voltage ( $U$ ). Instead, it depends on whether the voltage is increasing or decreasing. This creates a looped path on the graph, known as the hysteresis loop.
2. **Tolerance Band:** The reactive power values fluctuate within a specific tolerance band. When the voltage approaches the upper or lower limits of this band, the system's response is influenced by its previous state.
3. **Characteristic Curve:** The slope of the characteristic curve represents how reactive power changes with voltage. The hysteresis effect means that for the same voltage, the reactive power can have different values depending on the direction of the voltage change.
4. **Maximum Reactive Power Consumption:** The maximum reactive power consumption is described by the characteristic curve and the hysteresis behaviour. This ensures that the system can handle voltage fluctuations without instability.

### Explanation of Hysteresis Step

The diagram illustrates the concept of hysteresis in power control curves, specifically focusing on how reactive power (Q) responds to changes in voltage (U). Here's a detailed explanation:

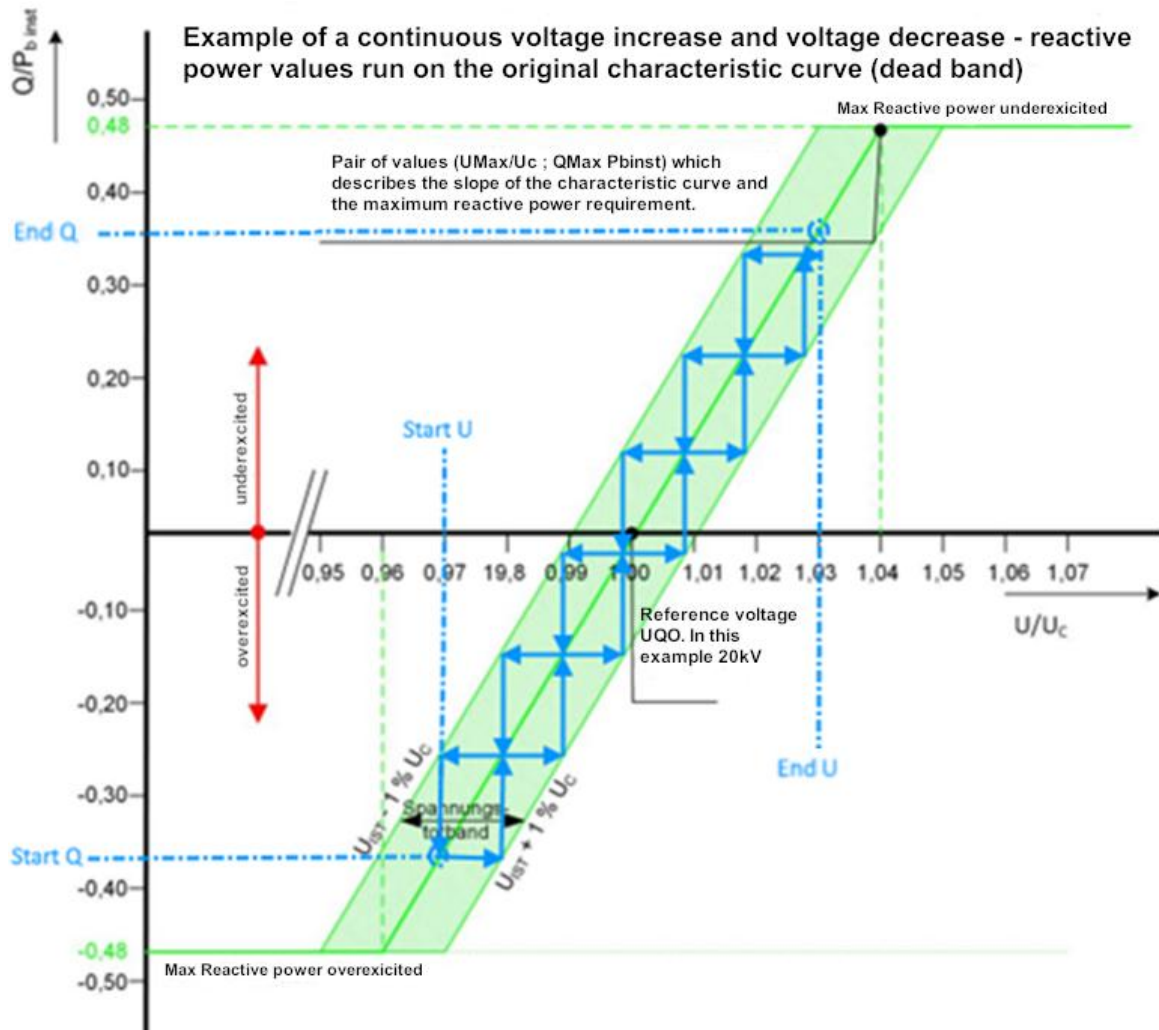

1. **Characteristic Curve:** The solid line represents the original characteristic curve, showing how reactive power changes with voltage. As voltage increases, reactive power also increases.
2. **Hysteresis Step Function:** The dashed line represents the hysteresis step function. Instead of a smooth, continuous change, the reactive power adjusts in discrete steps. This 'staircase' effect shows how the system tolerates minor fluctuations without making constant adjustments.
3. **Dead Band:** The area between the solid and dashed lines is the dead band. Within this range, the system does not respond to minor changes in voltage, preventing unnecessary adjustments and ensuring stability.
4. **Reactive Power Adjustment:** When the voltage exceeds the dead band limits, the system adjusts the reactive power in steps, rather than continuously. This helps in maintaining stability and efficiency in the power grid.

The importance of utilizing the hysteresis step function:

- **Stability:** By using a hysteresis step function, the system avoids constant switching, which can lead to instability.
- **Efficiency:** It ensures that the system only makes necessary adjustments, reducing wear and tear on components.

3.7.9.9.3 VDE POWER REACTIVE POWER CURVE

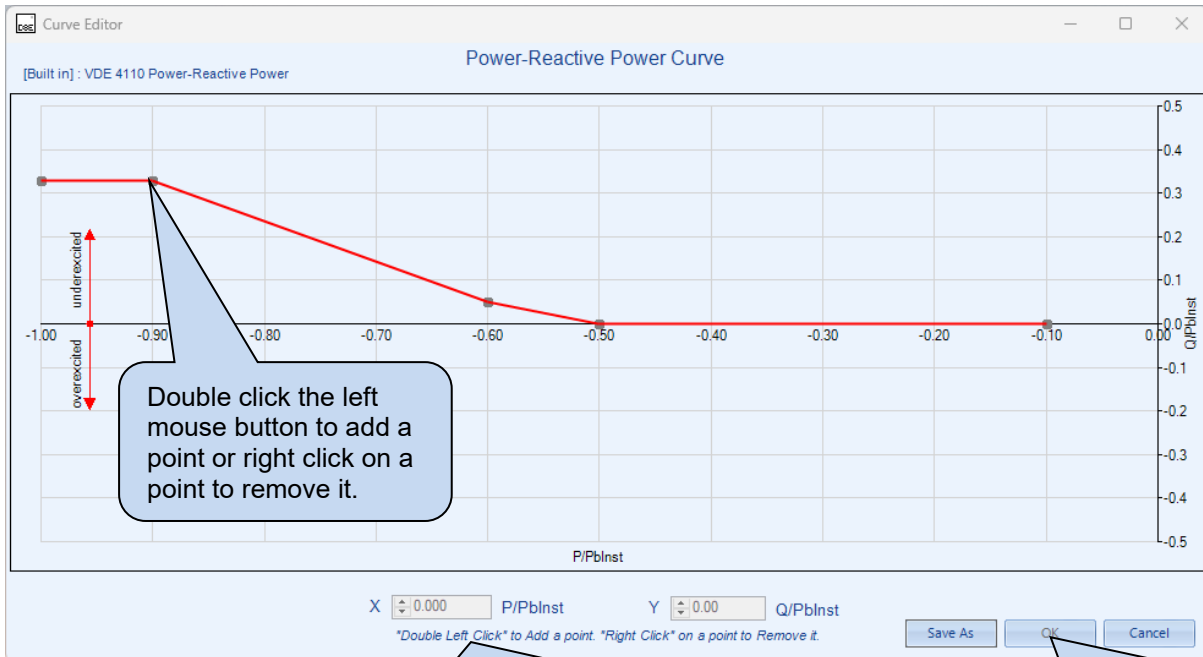

Use the mouse to select the graph point, then enter the value in the box or click up/down to change the value.

Click OK to accept the changes or *Cancel* to ignore and lose the changes. Click *Save As* to save the curve.

Parameter	Description
P/Pbinst	This represents the normalized active power. It is the ratio of the actual active power $P$ to the base power installation $P/P_{binst}$ .
Q/Pbinst	The VDE standard requires the Y axis of the graph to be defined as $Q/P_{binst}$ which is the ratio of reactive power to the generated power, e.g. 0.33 equals a power factor of 0.95.

3.7.9.9.4 VDE REACTIVE POWER LIMITED CURVE

**NOTE:** Qref\_Displ is adjusted remotely. Refer to section entitled *VDE Levels* in the SCADA section elsewhere in this document.

**NOTE:** All voltages are normalised to the Nominal Voltage. The VDE standard requires the Y axis of the graph to be defined as Q/Pbinst which is the ratio of reactive power to the generated power, e.g. 0.33 equals a power factor of 0.95.

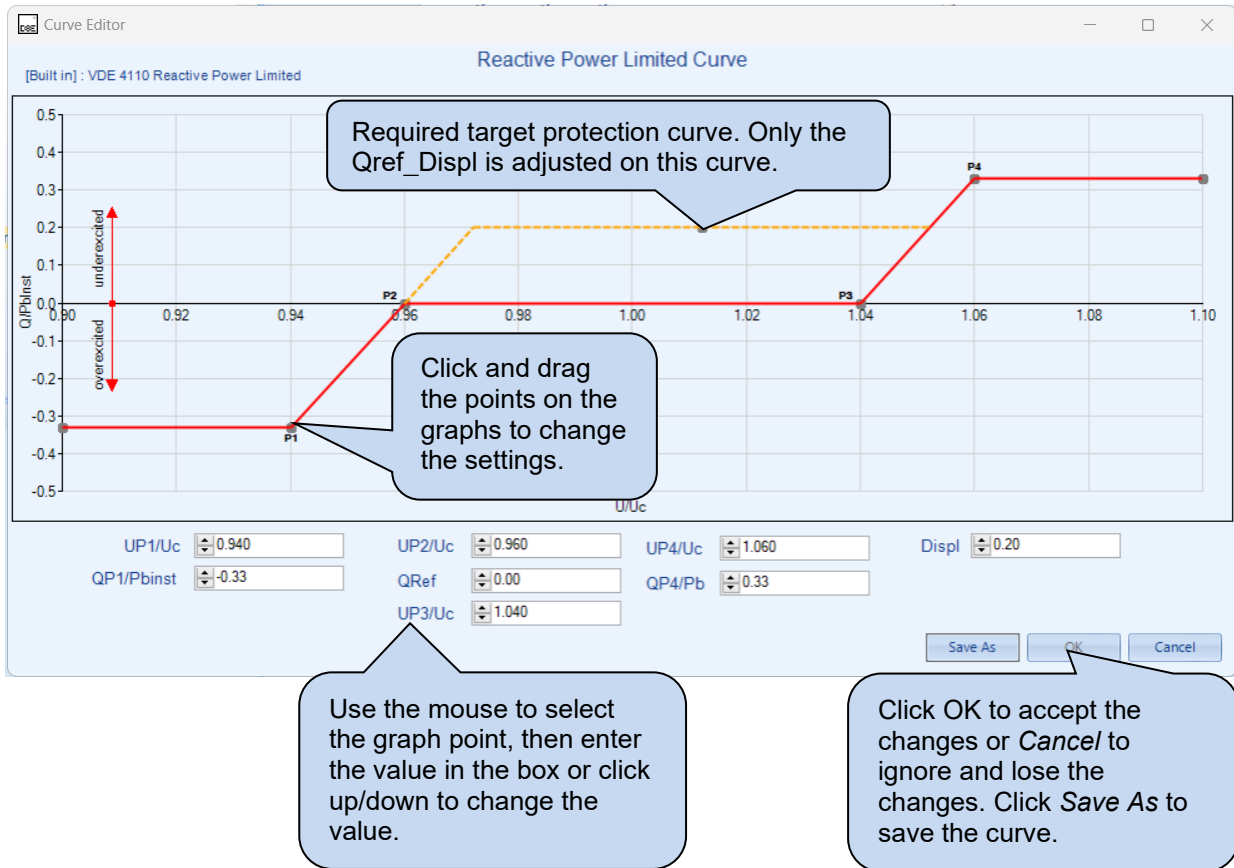

Parameter	Description
Up1/Uc	The Voltage corresponding to P1.
Qp1/Pbinst	The maximum Overexcited reactive power.
Up2/Uc	The Voltage corresponding to P2.
Qref	The reactive power between P2 and P3.
Up3/Uc	The Voltage corresponding to P3.
Up4/Uc	The Voltage corresponding to P4.
Qp4/Pb	The maximum Under excited reactive power.
Displ	The vertical displacement between P2 and P3, set remotely by the grid operator to define the operating power factor of the generator under normal grid voltages.

### 3.7.10 G99 FAULT RIDE THROUGH

 **NOTE:** To configure these settings refer to the appropriate grid standards for paralleling with the mains.

 **NOTE:** The *Fault Ride Through* feature is used to prevent the generator being disconnected from the Mains when in parallel during a momentary Mains Failure. Care **MUST** be taken when configuring the *Fault Ride Through* feature as a prolonged time in parallel with a failed mains might cause a damage to the generator.

The *Fault Ride Through* feature is useful to prevent Electrical Trips on voltage dips caused by the grid when the generator is running in *Multi Set* mode. This feature is also applicable on generators paralleling. The feature is to ignore the following *Electrical Trip* and *Shutdown* alarms:

- *Reverse Power*
- *Short Circuit*
- *Unbalanced Load*
- *Overcurrent*
- *Under Voltage*
- *Over Voltage*
- *Under Frequency*
- *Over Frequency*
- *Under Speed*
- *Over Speed*
- *Mains Decoupling Voltage & Frequency Stage Alarms*
- *Over Load*
- *Low Load*
- *Phase Rotation*
- *Earth Fault*

The *Fault Ride Through* curve must be configured which is formed of a sequence of *Connection Point Voltages* which increase after consecutive time intervals. The *Fault Ride Through* curve allows the generator to ignore the above list of alarms if the voltage remains above the specified curve during the transmission grid fault and recovery.

The curve starts when the voltage on one or more of the generator phases falls below the Urec3 level. The curve ends on the expiry of Trec4, after which all alarms trip as usual.

The *Connection Point Voltages* are configured in *PU (Per Unit)* which represent the percentages of the *Generator Nominal Voltage*; (i.e., 0.30PU = 30%). All the timers are configured in hundredths of a second.

## Editing the Configuration

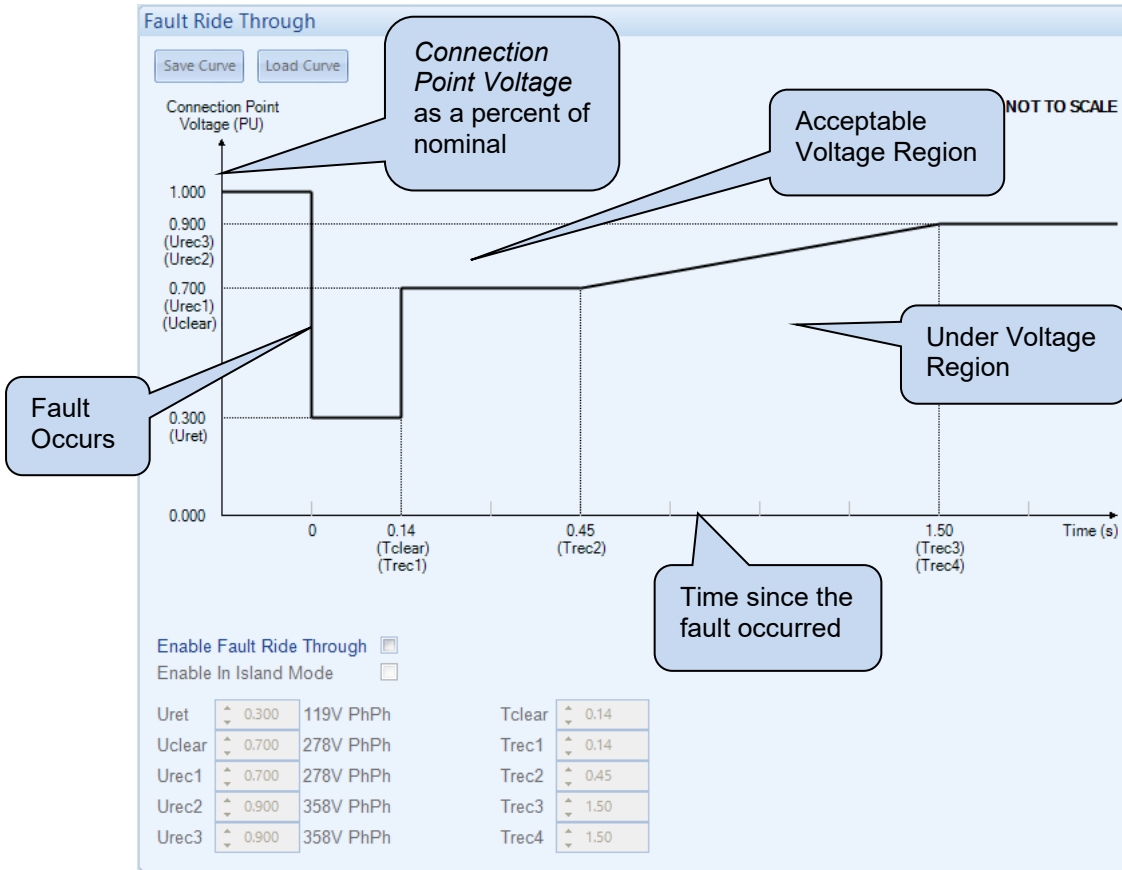

Parameter	Description
Enable Fault Ride Through	<input type="checkbox"/> = <i>Fault Ride Through</i> is disabled when in <i>Mains Parallel Mode</i> . <input checked="" type="checkbox"/> = <i>Fault Ride Through</i> is enabled when in <i>Mains Parallel Mode</i> .
Enable In Island Mode	<input type="checkbox"/> = <i>Fault Ride Through</i> is disabled when load sharing with generators only. <input checked="" type="checkbox"/> = <i>Fault Ride Through</i> is enabled when load sharing with generators only.
Uret	When the <i>Fault Ride Through</i> event starts, the voltage must remain above this level to ignore the <i>Gen Low Voltage Electrical Trip</i> or <i>Shutdown</i> alarm. This is the voltage that must be retained. If it falls below this then the list of alarms is enabled.
Tclear	During the normal operation when the voltage drops below the <i>Urec3</i> level this timer is started and the <i>Fault Ride Through</i> event is activated. After this time, the DSE module monitors the voltage to ensure it remains above the FRT curve to ignore the alarms. This timer ends at the next <i>Connection Point Voltage</i> ( <i>Uclear</i> ) of the curve. This is set longer than the clearance time of the transmission grid's circuit breakers.
Uclear	The next <i>Connection Point Voltage</i> level at the <i>Tclear</i> time, above which the voltage must be to ignore the <i>Gen Low Voltage Alarm</i> . The voltage must recover above this level after the transmission grid's circuit breaker clears, if not then the list of alarms is enabled.
Trec1	The time in seconds that the <i>FRT event</i> is active for. The voltage must be raised above the <i>Urec1</i> level at this time.
Urec1	The next <i>Connection Point Voltage</i> level after the <i>Trec1</i> time, above which the dipped voltage must be to ignore the <i>Gen Low Voltage Alarm</i> .
Trec2	The time in seconds that the <i>FRT event</i> is active for. After this time, the voltage must be raised above the <i>Urec1</i> level to ignore the <i>Gen Low Voltage Alarm</i> .

Parameter descriptions are continued overleaf...

## Editing the Configuration

Parameter	Description
Urec2	The next <i>Connection Point Voltage</i> level after the <i>Trec3</i> time, above which the voltage must be to ignore the <i>Gen Low Voltage Alarm</i> .
Trec3	The time in seconds that the <i>FRT event</i> is active. At this time, the voltage must be raised above the <i>Urec2</i> level, but if the voltage is still below the <i>Urec2</i> , then the <i>Fault Ride Through</i> event terminates and the alarms are no longer ignored.
Urec3	The next <i>Connection Point Voltage</i> level after the <i>Trec4</i> time, above which the voltage must be to terminate the <i>Fault Ride Through</i> event and activate the alarms.
Trec4	The time in seconds after which the DSE module monitors the voltage level to be raised above the <i>Urec3</i> to clear the <i>Fault Ride Through</i> event. The voltage must rise above <i>Urec3</i> for a new event to be started. The alarms are enabled at that time. If the voltage fails to stay over this part of the curve, then the list of alarms is enabled.

### Save / Load Curve

This feature is used to import the *Fault Ride Through* settings into another DSE module.

Parameter	Description
Save Curve	This allows saving the current configured settings of the <i>Fault Ride Through</i> into an FRT file.
Load Curve	This allows loading of previously configured settings of the <i>Fault Ride Through</i> saved in FRT format.

### 3.7.11 VDE AND IEEE FAULT RIDE THROUGH

 **NOTE:** To configure these settings refer to the appropriate grid standards for paralleling with the mains.

 **NOTE:** The *VDE and IEEE Fault Ride Through* feature is used to prevent the generator being disconnected from the Mains when in parallel during a momentary Mains Failure. Care **MUST** be taken when configuring the *VDE and IEEE Fault Ride Through* feature as a prolonged time in parallel with a failed mains might cause a damage to the generator.

The *VDE and IEEE Fault Ride Through* feature is useful to prevent Electrical Trips on voltage disturbances on the grid when in mains parallel. This feature is also enabled for use on generators running in island mode. The feature is to ignore the following *Electrical Trip* and *Shutdown* alarms:

- *Reverse Power*
- *Short Circuit*
- *Unbalanced Load*
- *Overcurrent*
- *Under Voltage*
- *Over Voltage*
- *Under Frequency*
- *Over Frequency*
- *Under Speed*
- *Over Speed*
- *Mains Decoupling Voltage & Frequency Stage Alarms*
- *Over Load*
- *Low Load*
- *Phase Rotation*
- *Earth Fault*

All standard VDE and IEEE FRT curves are provided, and custom curves can be defined.

The curves start to run when the voltage on one or more of the generator phases falls below the right most value of the lower curve or rises above the right most value of the upper curve.

All phase voltages must remain within the curves for the trips to remain blocked, if any goes below the lower curve or above the upper curve at any point then the block is removed and the alarms are permitted to trip, if so configured.

If the separate lower curve is enabled then separate curves are applied to symmetric faults, i.e. ones where all phases are affected equally, and asymmetric faults.

The *Connection Point Voltages* are configured in *PU (Per Unit)* which represent the percentages of the *Generator Nominal Voltage*; (i.e., 0.30PU = 30%).

All the timers are configured in hundredths of a second.

Editing the Configuration

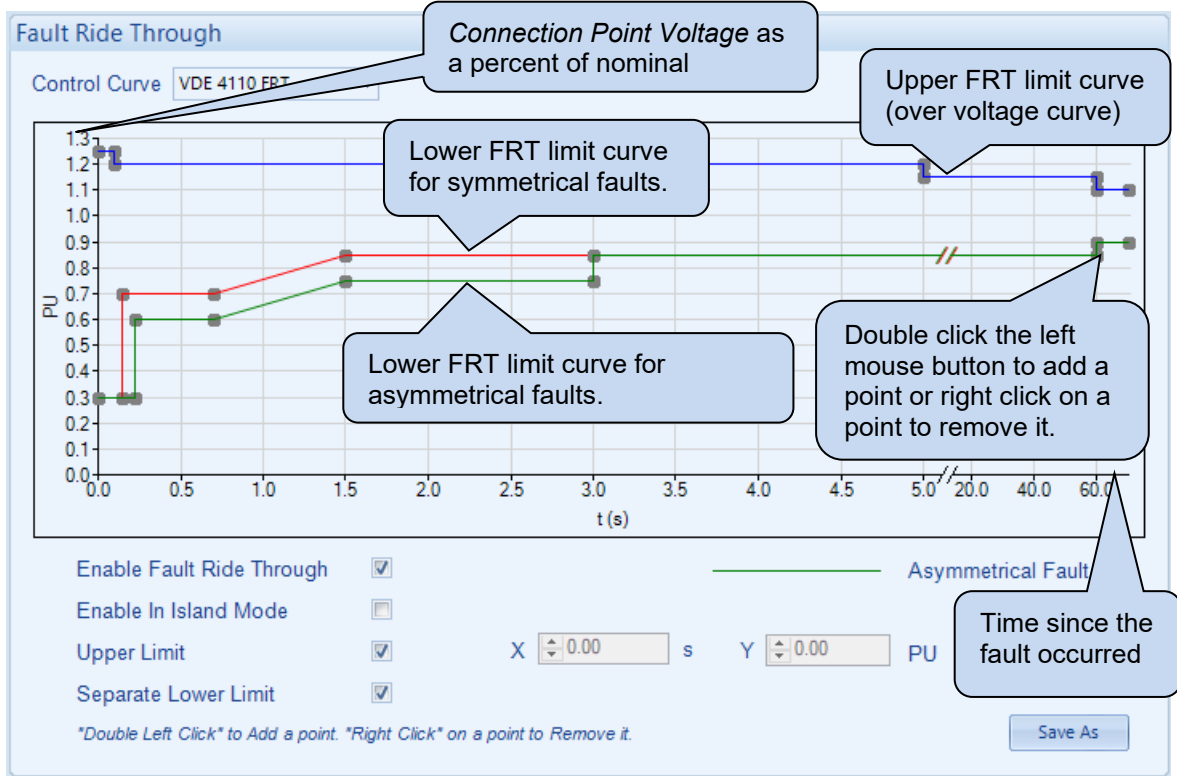

Parameter	Description
Control Curve	<p><b>NOTE:</b> The software includes predefined curves. By selecting a point, users can manipulate the curves and save their modifications.</p> <p>Select a pre-defined curve form the list:</p> <p><b>IEEE 1547 FRT CAT I</b>  <b>IEEE 1547 FRT CAT II</b>  <b>IEEE 1547 FRT CAT III</b>  <b>VDE 4105 FRT</b>  <b>VDE 4110 FRT</b></p>
Enable Fault Ride Through	<input type="checkbox"/> = Fault Ride Through is disabled. <input checked="" type="checkbox"/> = Fault Ride Through is enabled
Enable In Island Mode	<input type="checkbox"/> = Fault Ride Through is only enabled when in mains parallel. <input checked="" type="checkbox"/> = Fault Ride Through is enabled whenever the bus breaker is closed, whether in mains parallel or not.
Upper Limit	<input type="checkbox"/> = Select to remove the <i>Upper FRT limit curve</i> . <input checked="" type="checkbox"/> = Select to enable the <i>Upper FRT limit curve</i> .
Separate Lower Limit	<input type="checkbox"/> = Select to use a single <i>Lower FRT limit curve</i> . <input checked="" type="checkbox"/> = Select to use separate symmetrical and asymmetrical <i>Lower FRT limit curves</i> .
Save As	This allows saving the current configured settings of the <i>VDE and IEEE Fault Ride Through</i> into an FRT file.

### **3.8 BUS (MULTI SET)**

The Bus section is subdivided into smaller sections.

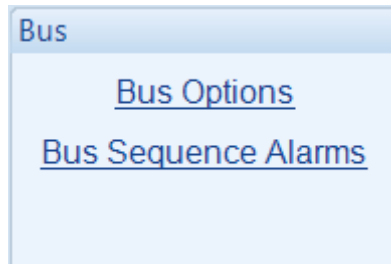

### 3.8.1 BUS OPTIONS

#### Bus Settings

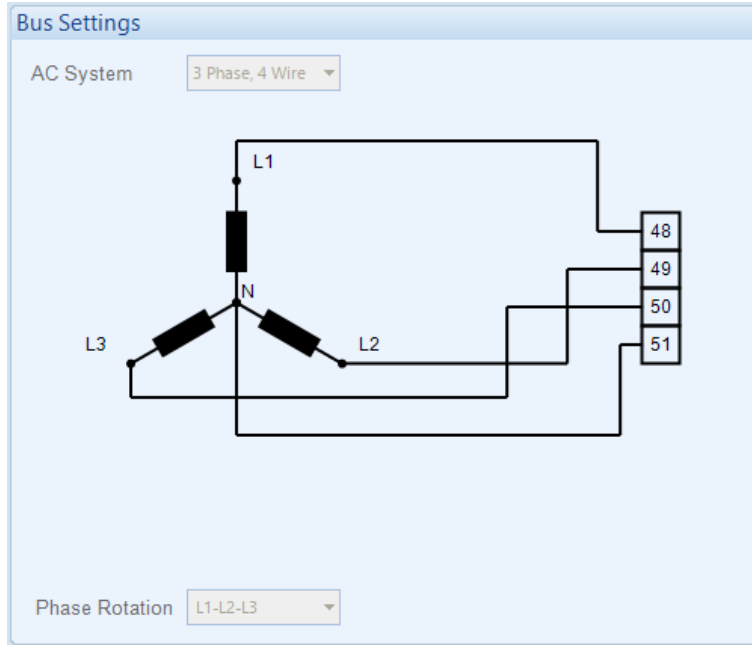

Parameter	Description
Bus Settings	All the <i>Bus Settings</i> are locked to the same configuration as the <i>Generator Settings</i> . This section is displayed for clarification purposes only.

#### Bus Phase Rotation

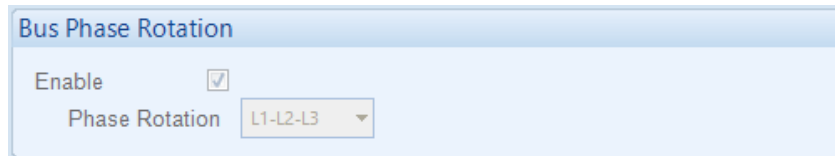

Parameter	Description
Bus Phase Rotation	All the <i>Bus Phase Rotation</i> settings are locked to the same configuration as the <i>Generator Phase Rotation</i> settings. This section is displayed for clarification purposes only.

### 3.8.2 BUS SEQUENCE ALARMS

**NOTE:** The alarms in this section are Voltage Sequence Alarms.

#### Zero sequence Alarm

**Zero Sequence Alarm**

Enable  *Zero Sequence should be set to a third of the required NVD value.*

Action Electrical Trip

Arming Always

Trip 39.8 V PhPh 
10.0%
39.8V PhPh

Delay 0.0s

Parameter	Description
Enable	<p><b>NOTE:</b> The Zero Sequence Alarm must be set to a third of the required Neutral Voltage Displacement (NVD) value. This is because the summation of the three Zero Sequence vector components is equal to the NVD value.</p> <p><input type="checkbox"/> = Zero Sequence is disabled  <input checked="" type="checkbox"/> = Zero Sequence is enabled</p>
Action	<p>Activates when zero sequence is greater than the trip value. For more information see the section entitled <i>Alarm Types</i> elsewhere in this document. The alarm action list is as follows:</p> <p><b>Auxiliary Mains Fail</b>  <b>Electrical Trip</b>  <b>Warning</b></p> <p><b>NOTE:</b> If the Action is set as <i>Electrical Trip</i> and the bus is not live, then the alarm is generated, and the generator does not start.</p>
Arming	<p>Select when the alarm is active For further information see the section entitled <i>Alarm Arming</i> elsewhere in this document. The alarm arming list is as follows:</p> <p><b>Active from Mains Parallel</b>  <b>Always</b>  <b>From Safety On</b></p>
Trip	Set the voltage and percentage of zero sequence at which the Alarm is activated.
Delay	Set the amount of time before the <i>zero-sequence alarm is activated</i> .

**Positive Sequence Alarm**



Parameter	Description
Enable	<input type="checkbox"/> = <i>Positive Sequence</i> is disabled <input checked="" type="checkbox"/> = <i>Positive Sequence</i> is enabled
Action	Activates when positive sequence is greater than the trip value. See the section entitled <i>Alarm Types</i> elsewhere in this document. The alarm action list is as follows:  <b><i>Auxiliary Mains Fail</i></b> <b><i>Electrical Trip</i></b> <b><i>Warning</i></b>
Arming	Select when the alarm is active For further information see the section entitled <i>Alarm Arming</i> elsewhere in this document. The alarm arming list is as follows:  <b><i>Active from Mains</i></b> <b><i>Always</i></b> <b><i>From Safety On</i></b>
Trip	Set the voltage and percentage of positive sequence at which the Alarm is activated.
Delay	Set the amount of time before the <i>positive sequence alarm is activated</i> .

**Negative Sequence Alarm**

**NOTE:** The trip level is calculated as follows. Number of phases x trip level % x full load amps.

Parameter	Description
Enable	<input type="checkbox"/> = <i>Negative Sequence</i> is disabled <input checked="" type="checkbox"/> = <i>Negative Sequence</i> is enabled
Action	Select which action is activated. The alarm action list is as follows, see section entitled <i>Alarm Types</i> elsewhere in this document:  <b>Auxiliary Mains Fail</b> <b>Electrical Trip</b> <b>Warning</b>
Arming	Select when the alarm is active For further information see the section entitled <i>Alarm Arming</i> elsewhere in this document. The alarm arming list is as follows:  <b>Active from Mains Parallel</b> <b>Always</b> <b>From Safety On</b>
Trip	Set the voltage and percentage of negative sequence at which the Alarm is activated.
Delay	Set the amount of time before the <i>negative sequence alarm is activated</i> .

**Asymmetry Alarm**

Parameter	Description
Enable	<input type="checkbox"/> = <i>Asymmetry</i> Alarm is disabled <input checked="" type="checkbox"/> = <i>Asymmetry</i> is Alarm is enabled
Action	Activates when asymmetry is greater than the trip value. The alarm action list is as follows, see section entitled <i>Alarm Types</i> elsewhere in this document:  <b>Fail</b> <b>Electrical Trip</b> <b>Warning</b>
Arming	Select when the alarm is active For further information see the section entitled <i>Alarm Arming</i> elsewhere in this document. The alarm arming list is as follows:  <b>Active from Mains Parallel</b> <b>Always</b> <b>From Safety On</b>
Trip	Set the voltage and percentage of asymmetry at which the Alarm is activated.
Delay	Set the amount of time before the <i>asymmetry alarm is activated</i> .

### **3.9 MAINS (SINGLE SET ONLY)**

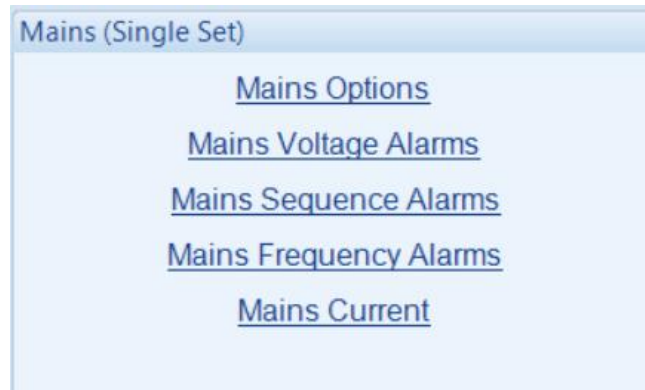

### 3.9.1 MAINS OPTIONS

#### Mains Options

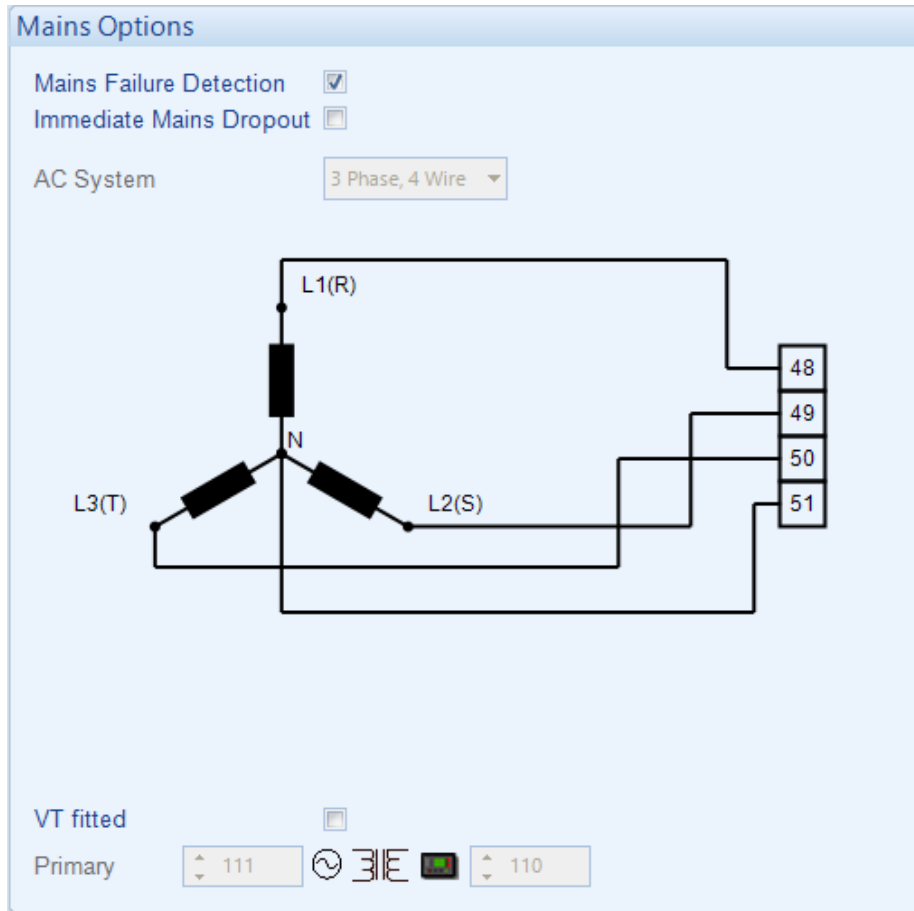

Parameter	Description
Mains Failure Detection	<input type="checkbox"/> = Mains Failure Detection is disabled. <input checked="" type="checkbox"/> = Mains Failure Detection is enabled.
Immediate Mains Dropout	<input type="checkbox"/> = Upon mains failure, the mains load switch is kept closed until the generator is up to speed and volts. <input checked="" type="checkbox"/> = Upon mains failure, the mains load switch is opened immediately, subject to the setting of the <i>mains transient</i> timer.
AC System	The AC System of the mains is fixed to the same setting as the generator. These settings are used to detail the type of AC system to which the module is connected: <b>2 Phase, 3 Wire L1 - L2</b> <b>2 Phase, 3 Wire L1 - L3</b> <b>3 Phase, 3 Wire NVD</b> <b>3 Phase, 3 Wire</b> <b>3 Phase, 4 Wire</b> <b>3 Phase, 4 Wire Delta L1 - N - L2</b> <b>3 Phase, 4 Wire Delta L1 - N - L3</b> <b>3 Phase, 4 Wire Delta L2 - N - L3</b> <b>Single Phase, 2 Wire</b> <b>Single Phase, 3 Wire L1 - L2</b> <b>Single Phase, 3 Wire L1 - L3</b>

Parameters detailed overleaf...

Parameter	Description
VTs	<input type="checkbox"/> = The voltage sensing to the controller is direct from the Mains <input checked="" type="checkbox"/> = The voltage sensing to the controller is via Voltage Transformers (VTs or PTs)  This is used to step down the mains voltage to be within the controller voltage specifications. By entering the <i>Primary</i> and <i>Secondary</i> voltages of the transformer, the controller displays the <i>Primary</i> voltage rather than the actual measured voltage.  This is typically used to interface the DSE module to high voltage systems (i.e., 11 kV).

**Mains Phase Rotation**

**Mains Phase Rotation**

Enable

Phase Rotation L1-L2-L3

Parameter	Description
Mains Phase Rotation <small>IEEE C37.2 – 47 Phase Sequence Relay</small>	<input type="checkbox"/> = Mains phase rotation is not checked. <input checked="" type="checkbox"/> = A mains failure is detected when the measured phase rotation is not as configured.

**Breaker Control**

**Breaker Control**

Enable Breaker Alarms

Fail to Open Delay 1.0s

Fail to Close Delay 1.0s

Parameter	Description
Enable Breaker Alarms	<input type="checkbox"/> = Alarm is disabled <input checked="" type="checkbox"/> = The <i>Mains Breaker Alarms</i> are enabled.
Fail To Close Delay	When the <i>Close Mains</i> output is activated, if the configured <i>Mains Closed Auxiliary</i> digital input does not become active within the <i>Mains Fail To Close Delay</i> timer, the alarm is activated.
Fail To Open Delay	When the <i>Open Mains</i> output is activated, if the configured <i>Mains Closed Auxiliary</i> digital input does not become inactive within the <i>Mains Fail To Open Delay</i> timer, the alarm is activated.

**Phase Offset**

**⚠ CAUTION!** Editing the phase offset is only allowed when the checkbox is ticked. This setting is only required if a phase offset is available and is not altered otherwise. If the setting is adjusted and no phase offset is required, then crash synchronisation (improper synchronisation of generator's frequency, voltage, and phase angle with the grid) may occur. This option is only available on the Single Set Controller.

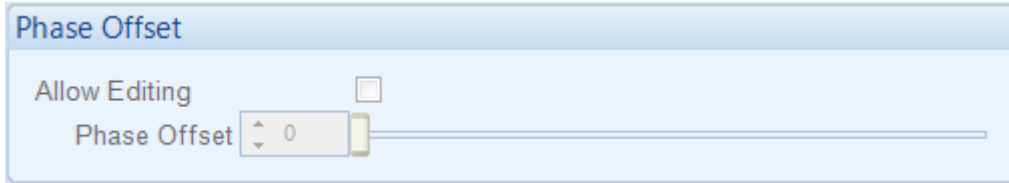

Parameter	Description
Allow Editing	<input type="checkbox"/> = Allow Editing is disabled. <input checked="" type="checkbox"/> = Allow Editing is enabled.
Phase Offset	Set the phase angle between the VT primary and secondary.

### 3.9.2 MAINS VOLTAGE ALARMS

#### Under Voltage Alarms

Parameter	Description
Mains Under Voltage Alarm IEEE C37.2 - 27AC Undervoltage Relay	<input type="checkbox"/> = Mains Under Volts does NOT give an alarm. <input checked="" type="checkbox"/> = The module detects a Mains Failure when the mains supply voltage falls below the configured <i>Under Volts Alarm Trip</i> value for longer than the <i>Mains Transient Delay</i> . The <i>Undervolts Alarm Trip</i> value is adjustable to suit user requirements.

#### Nominal Voltage

Parameter	Description
Nominal Voltage	This is used to calculate the percentage of mains failure thresholds by the voltage alarm limits.

#### Overvoltage Alarms

Parameter	Description
Mains Over Voltage IEEE C37.2 – 59 AC Overvoltage Relay	<input type="checkbox"/> = Alarm is disabled. <input checked="" type="checkbox"/> = The module detects a Mains Failure when the mains supply voltage rises above the configured <i>Over Volts Alarm Trip</i> value for longer than the <i>Mains Transient Delay</i> . The <i>Overvolts Alarm Trip</i> value is adjustable to suit user requirements.

### 3.9.3 MAINS SEQUENCE ALARMS

#### Zero Sequence Alarm

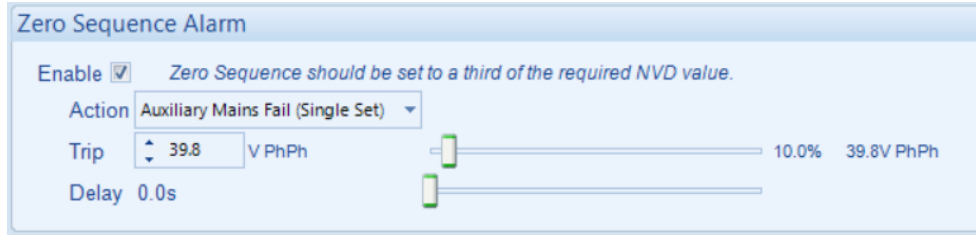

Parameter	Description
Zero Sequence Alarm IEEE C37.2 – 47H Phase-Sequence or Phase Balance Voltage Relay	<p><b>NOTE:</b> The Zero Sequence Alarm must be set to a third of the required Neutral Voltage Displacement (NVD) value. This is because the summation of the three Zero Sequence vector components is equal to the NVD value.</p> <p>This is also known as Neutral Voltage Displacement.  <input type="checkbox"/> = Alarm is disabled.  <input checked="" type="checkbox"/> = The alarm activates when the difference in potential between the Earth and the calculated Neutral position of a 3-wire delta exceeds the configured <i>Zero Sequence Alarm Trip</i> level for the configured <i>Delay</i> time.</p>
Action	<p>Select the type of alarm required from the list:  <b>Single Set</b>  <b>Electrical Trip</b>  <b>Warning</b>                      For details of these, see the section entitled <i>Alarm Types</i> elsewhere in this document.</p>

#### Positive Sequence Alarm

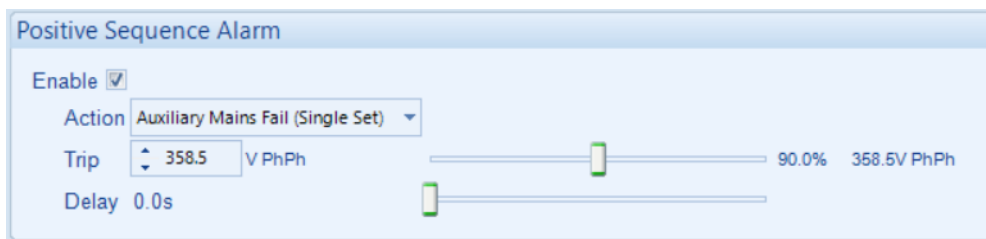

Parameter	Description
Positive Sequence Alarm IEEE C37.2 – 47L Phase-Sequence or Phase Balance Voltage Relay	<p><input type="checkbox"/> = Alarm is disabled  <input checked="" type="checkbox"/> = The alarm activates when the <i>Positive Sequence</i> voltage falls below the configured <i>Positive Sequence Alarm Trip</i> level for the configured <i>Delay</i> time.</p>
Action	<p>Select the type of alarm required from the list:  <b>Single Set</b>  <b>Electrical Trip</b>  <b>Warning</b>                      For details of these, see the section entitled <i>Alarm Types</i> elsewhere in this document.</p>

**Negative Sequence Alarm**

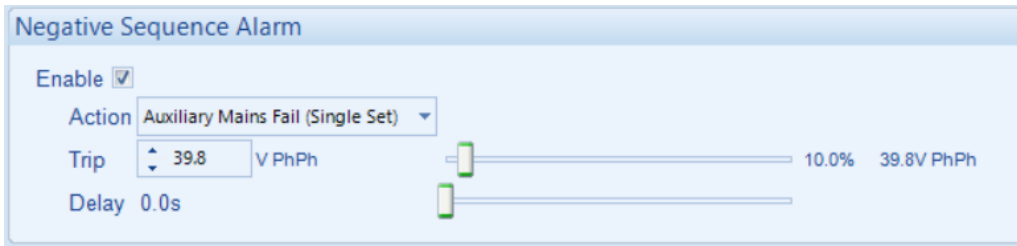

Parameter	Description
Negative Sequence Alarm IEEE C37.2 – 47H Phase-Sequence Or Phase Balance Voltage Relay	<input type="checkbox"/> = Alarm is disabled <input checked="" type="checkbox"/> = The alarm activates when the <i>Negative Sequence</i> voltage exceeds the configured <i>Negative Sequence Alarm</i> level for the configured <i>Delay</i> time.
Action	Select the type of alarm required from the list: <b>Single Set</b> <b>Electrical Trip</b> <b>Warning</b> For details of these, see the section entitled <i>Alarm Types</i> elsewhere in this document.

**Asymmetry Alarm**

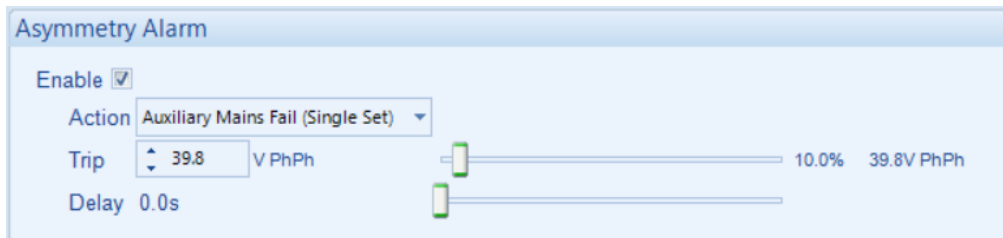

Parameter	Description
Asymmetry Alarm IEEE C37.2 – 59 Overvoltage Relay	<input type="checkbox"/> = Alarm is disabled <input checked="" type="checkbox"/> = The alarm activates when the voltage between any two phases exceeds the configured <i>Asymmetry Alarm Trip</i> level for the configured <i>Delay</i> time. <b>For example:</b> L1=230, L2=235, L3=226 Asymmetry is <i>largest value – smallest value = 235 – 226 = 9V</i>
Action	Select the type of alarm required from the list: <b>Single Set</b> <b>Electrical Trip</b> <b>Warning</b> For details of these, see the section entitled <i>Alarm Types</i> elsewhere in this document.

### 3.9.4 MAINS FREQUENCY ALARMS

#### Under Frequency Alarm

The screenshot shows a configuration window titled "Under Frequency Alarms". At the top left, there is an "Enable" checkbox which is checked. Below this, there are two rows of controls. The first row is for the "Trip" value, which is set to 45.0 Hz. The second row is for the "Return" value, which is set to 48.0 Hz. Each value is shown in a small input box with up and down arrows, and a corresponding slider bar to its right.

Parameter	Description
Mains Under Frequency Alarm IEEE C37.2 -81 Frequency Relay	<input type="checkbox"/> = Mains Under Frequency does NOT give an alarm. <input checked="" type="checkbox"/> = The module detects a Mains Failure when the mains supply frequency falls below the configured <i>Under Frequency Alarm Trip</i> value for longer than the <i>Mains Transient Delay</i> . The <i>Underfrequency Alarm Trip</i> value is adjustable to suit user requirements.

#### Over Frequency Alarm

The screenshot shows a configuration window titled "Over Frequency Alarms". At the top left, there is an "Enable" checkbox which is checked. Below this, there are two rows of controls. The first row is for the "Return" value, which is set to 52.0 Hz. The second row is for the "Trip" value, which is set to 55.0 Hz. Each value is shown in a small input box with up and down arrows, and a corresponding slider bar to its right.

Parameter	Description
Mains Over Frequency IEEE C37.2 -81 Frequency Relay	<input type="checkbox"/> = Alarm is disabled. <input checked="" type="checkbox"/> = The module detects a Mains Failure when the mains supply frequency rises above the configured <i>Over Frequency Alarm Trip</i> value for longer than the <i>Mains Transient Delay</i> . The <i>Over Frequency Alarm Trip</i> value is adjustable to suit user requirements.

### 3.9.5 MAINS CURRENT

#### Mains Current Options

Parameter	Description
Mains CT Enabled	<input type="checkbox"/> = Mains CT disabled <input checked="" type="checkbox"/> = Mains CT enabled. Only one CT for measuring mains current. The system assumes a balanced kw & kvar load and all phases mirror L1.
CT Primary (L1)	Primary rating of the three phase Current Transformers
CT Secondary	Secondary rating of the Current Transformers
Full Load Rating Full kvar Rating	Full load rating (100% rating) of the mains supply. The kW and kvar rating must be correctly set. The values set here are the kW and kvar, <b>NOT</b> the kVA or Power Factor!  These values are used for many functions including <i>Mains Power</i> and <i>Load Share</i> functions.

#### Mains Reverse Power (Mains Export Limit)

Parameter	Description
Export Power	<input type="checkbox"/> = The DSE module does not monitor the export kilowatt. <input checked="" type="checkbox"/> = the DSE module measures power exported to the mains supply and provides an alarm condition if the <i>Export Power</i> value is exceeded by the <i>Trip</i> value for the configured <i>Delay</i> time.
Action	Select the type of alarm required from the list: <b>Electrical Trip</b> <b>Warning</b> For details of these, see section entitled <i>Alarm Types</i> elsewhere in this document.

### 3.10 MAINS DECOUPLING

**NOTE:** The *Mains Decoupling* protections only have effect when a digital input is configured for *Mains Parallel* mode instructing the module to operate in fixed export mode with the utility supply. In *Single Set* mode the Mains Decoupling protections have effect when the generator is in parallel with the Mains For more information on this application, refer to DSE Publication: *056-054 DSE8x10 in Fixed Export (Base Load)* which is found on our website: [www.deepseaelectronics.com](http://www.deepseaelectronics.com)

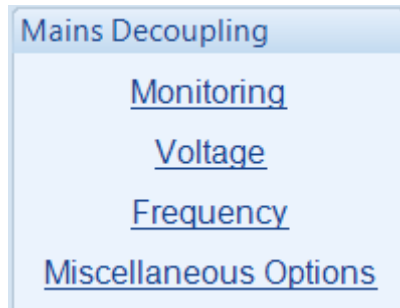

The *Mains Decoupling* section is subdivided into smaller sections. Select the required section with the mouse.

The controller includes “Mains decoupling” detection to be used with generating sets paralleling with the Mains (utility) supply.

When the generator set is in parallel with the Mains supply it is important that failure of the Mains is detected as soon as possible otherwise problems arise. It is not possible to simply monitor the Mains voltage and frequency as the sensing of this is now being fed by the generator itself!

Because of this and other possible dangerous situations, the power supply companies impose regulations when generators are in parallel. This is to detect Mains failure during parallel operation and to remove the generator from the grid in this situation.

Failure to detect and act upon loss of Mains supply when in parallel leads to the following effects:

- The generator feeds the site load and attempts to feed the load of the grid. Depending upon the generator size and the location of the network fault, this causes problems to the generator in terms of capacity and stability.
- If the generator is able to supply the load, Engineers working on the supposedly dead network would be in fact working on live cables, supplied by the generator set. This is potentially fatal.
- When the Mains supply is reconnected and the generator is still connected to the grid, the network would be connected to a generator not synchronised with it, with damaging results (mechanical failure, rotating diode failure, overloaded cables, pole slip etc)

### 3.10.1.1 MONITORING

#### Limits

 **NOTE: Pressing the *Reset to Default* button restores the standards to their preset values.**

Limits

Impose Mains Disconnection Limits No Limits ▾ Reset to Default

Parameter	Description
Impose Mains Disconnection Limits	<p> <b>NOTE: The Mains Disconnection Limits are established in the Monitoring section, and the limit is defined in all other sections within Mains Decoupling.</b></p> <p>Select the type of limit required from the list:  <b>IEEE1547 Category I</b>  <b>IEEE1547 Category II</b>  <b>IEEE1547 Category III</b>  <b>VDE-AR-N 4110:2018 Power generating unit</b></p>

#### Options

Options

Alarm Action (Single Set) Electrical Trip ▾

Alarm Action (Multi Set) Electrical Trip ▾

Mains Decoupling Supervision 1.0s

Parameter	Description
Alarm Action (Single Set)	<p>Select the type of alarm required from the list:</p> <p><b>Auxiliary Mains Fail (Single Set)</b> – Opens the mains load switch and allows the bus to continue providing power to the load.</p> <p><b>Electrical Trip</b> – The bus load switch is opened, and the set is allowed to perform a cooling run before being stopped.</p> <p><b>Warning</b> – Audible alarm is generated. Breakers are not opened.</p> <p><b>Warning &amp; trip gen / bus breaker</b>– Audible alarm is generated, and the gen / bus breaker is tripped. When the alarm conditions have cleared, the bus breaker is allowed to automatically reclose in <i>Auto Mode</i>.</p> <p><b>Warning &amp; trip mains breaker</b>– Audible alarm is generated, and the mains breaker is tripped. When the alarm conditions have cleared, the mains breaker is allowed to automatically reclose in <i>Auto Mode</i>.</p>

Parameter descriptions are continued overleaf...

Editing the Configuration

Parameter	Description
Alarm Action (Multi Set)	Select the type of alarm required from the list: <b>Electrical Trip</b> – The bus load switch is opened, and the set is allowed to perform a cooling run before being stopped. <b>Warning</b> – Audible alarm is generated. Breakers are not opened. <b>Warning &amp; trip gen / bus breaker</b> – Audible alarm is generated, and the gen / bus breaker is tripped. When the alarm conditions have cleared, the bus breaker is allowed to automatically reclose in auto mode.
Mains Decoupling Supervision	This activates the decoupling after a preset time.

**Cut in conditions (Initial connection)**

**NOTE:** In a Single Set application the nominal voltage used for the power unit (PU) is derived from the mains supply. In a Multi Set application the nominal voltage used for the power unit (PU) is derived from the bus.

Parameter	Description
Mains CT Enabled	<input type="checkbox"/> = Cut in conditions disabled <input checked="" type="checkbox"/> = Cut in conditions enabled.
Low voltage	The low voltage connection limit.
High voltage	The high voltage connection limit.
Low Frequency	The low frequency connection limit.
High Frequency	The high frequency connection limit.
Monitoring Time	The period within which all the limits must be adhered to. If any of the limits are exceeded, the monitoring process will be restarted.

**Cut in conditions (Post decoupling event)**

**NOTE:** Enabling *Stop Mode* will not remove the requirement to go through the post decoupling. To restore the initial conditions, it is advisable to disconnect the remote start digital input which in turn will open the breaker.

Parameter	Description
Mains CT Enabled	<input type="checkbox"/> = Cut in conditions disabled <input checked="" type="checkbox"/> = Cut in conditions enabled.
Low voltage	The low voltage connection limit.
High voltage	The high voltage connection limit.
Low Frequency	The low frequency connection limit.
High Frequency	The high frequency connection limit.
Monitoring Time	The period within which all the limits must be adhered to. If any of the limits are exceeded, the monitoring process will be restarted.

### 3.10.1.2 VOLTAGE

#### Limits

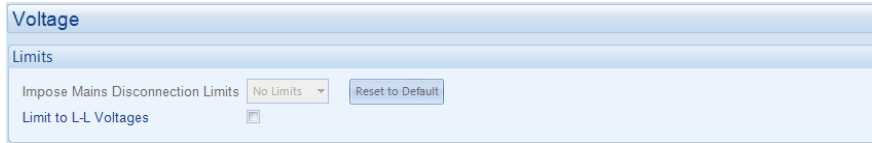

Parameter	Description
Impose Mains Disconnection Limits	<p><b>NOTE:</b> Category I to III Limits are only applicable for 60Hz nominal frequency. The <i>VDE-AR-N 4110:2018 Power generating unit</i> limit is only applicable to 50Hz.</p> <p>Limit the Mains Decoupling Alarms, options are:  <b>No Limits</b>  <b>Category I Limit</b>  <b>Category II Limit</b>  <b>Category III Limit</b>  <b>VDE-AR-N 4110:2018 Power generating unit</b></p>
Limit to L-L Voltages	<p><input type="checkbox"/> = Mains Disconnection Limits are applied to both Line to line (L-L) and line to neutral (L-N) voltages where appropriate to the AC systems.  <input checked="" type="checkbox"/> = Mains Disconnection Limits are only applied to line to line (L-L) voltages, never to line to neutral (L-N) voltages, regardless of the AC system.</p>

#### Under Voltage Alarms

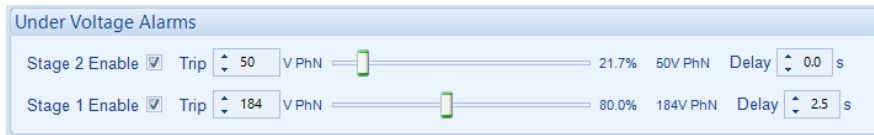

Parameter	Description
Mains Under Voltage, Stage 1 to Stage 2 IEEE C37.2 - 27AC Undervoltage Relay	<p>These are '2 stage' alarms.  Stage 1 allows for a delayed operation if the voltage strays by a small amount.  Stage 2 allows for a faster trip if the voltage changes by a larger amount.  <input type="checkbox"/> = Mains Under Voltage does NOT give an alarm.  <input checked="" type="checkbox"/> = Mains Under Voltage protection is enabled when the generator is in parallel with the Mains supply and an input configured for <i>Mains Parallel Mode</i> is active. The alarm activates when the Mains voltage falls below the configured <i>Under Voltage Alarm Trip</i> value for longer than the <i>Delay</i>. The <i>Under Voltage Alarm Trip</i> value is adjustable to suit user requirements.</p>

#### Nominal Voltage

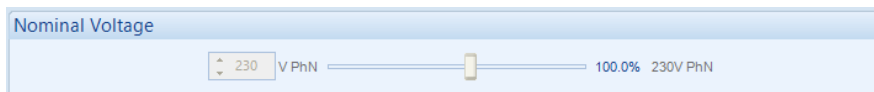

Parameter	Description
Mains Nominal Voltage	The <i>Mains Nominal Voltage</i> is locked to the same configuration as the <i>Generator Nominal Voltage</i> . This section is displayed for clarification purposes only.

**Over Voltage Alarms**

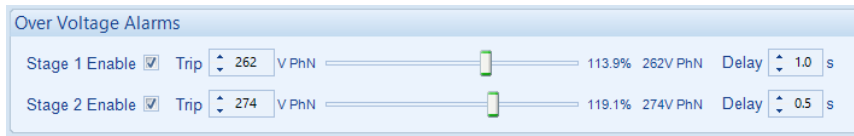

Parameter	Description
Mains Over Voltage, Stage 1 to Stage 2 IEEE C37.2 - 59AC Overvoltage Relay	<p>These are '2 stage' alarms.</p> <p>Stage 1 allows for a delayed operation if the voltage strays by a small amount.</p> <p>Stage 2 allows for a faster trip if the voltage changes by a larger amount.</p> <p><input type="checkbox"/> = Mains Over Voltage does NOT give an alarm.</p> <p><input checked="" type="checkbox"/> = Mains Over Voltage protection is enabled when the generator is in parallel with the Mains supply and an input configured for <i>Mains Parallel Mode</i> is active. The alarm activates when the Mains voltage rises above the configured <i>Over Voltage Alarm Trip</i> value for longer than the <i>Delay</i>. The <i>Over Voltage Alarm Trip</i> value is adjustable to suit user requirements.</p>

### 3.10.1.3 FREQUENCY

#### Limits

Limits

Impose Mains Disconnection Limits IEEE1547 Category II Reset to Default Invalid nominal frequency for the selected limits

Parameter	Description
Impose Mains Disconnection Limits	<p><b>⚠️ NOTE: Category I to III Limits are only applicable for 60Hz nominal frequency. The VDE-AR-N 4110:2018 Power generating unit limit is only applicable to 50Hz.</b></p> <p>Limit the Mains Decoupling Alarms, options are:  <b>No Limits</b>  <b>Category I Limit</b>  <b>Category II Limit</b>  <b>Category III Limit</b>  <b>VDE-AR-N 4110:2018 Power generating unit</b></p>

#### Under Frequency Alarms

Under Frequency Alarms

Stage 2 Enable  Trip 47.00 Hz  94.0% Delay 0.50 s

Stage 1 Enable  Trip 47.50 Hz  95.0% Delay 20.00 s

Parameter	Description
Mains Under Frequency, Stage 1 to Stage 2 <span style="color: orange;">IEEE C37.2 – 81L Frequency Relay</span>	<p>These are '2 stage' alarms.                      Stage 1 allows for a delayed operation if the frequency strays by a small amount.                      Stage 2 allows for a faster trip if the frequency changes by a larger amount.</p> <p><input type="checkbox"/> = Mains Under Frequency does NOT give an alarm  <input checked="" type="checkbox"/> = Mains Under Frequency protection is enabled when the generator is in parallel with the Mains supply and an input configured for <i>Mains Parallel Mode</i> is active. The alarm activates when the Mains frequency falls below the configured <i>Under Frequency Alarm Trip</i> value for longer than the <i>Delay</i>. The <i>Under Frequency Alarm Trip</i> value is adjustable to suit user requirements.</p>

**Nominal Frequency**

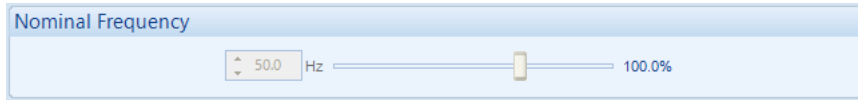

Parameter	Description
Mains Nominal Frequency	The <i>Mains Nominal Frequency</i> is locked to the same configuration as the <i>Generator Nominal Frequency</i> . This section is displayed for clarification purposes only.

**Over Frequency Alarms**

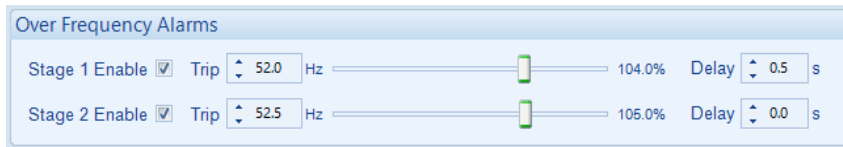

Parameter	Description
Mains Over Frequency, Stage 1 to Stage 5 IEEE C37.2 – 81H Frequency Relay	<p>These are '2 stage' alarms.</p> <p>Stage 1 allows for a delayed operation if the frequency strays by a small amount.</p> <p>Stage 2 allows for a faster trip if the frequency changes by a larger amount.</p> <p><input type="checkbox"/> = Mains Over Frequency does NOT give an alarm</p> <p><input checked="" type="checkbox"/> = Mains Over Frequency protection is enabled when the generator is in parallel with the Mains supply and an input configured for <i>Mains Parallel Mode</i> is active. The alarm activates when the Mains voltage rises above the configured <i>Over Frequency Alarm Trip</i> value for longer than the <i>Delay</i>. The <i>Over Frequency Alarm Trip</i> value is adjustable to suit user requirements.</p>

### 3.10.1.4 MISCELLANEOUS OPTIONS

#### Limits

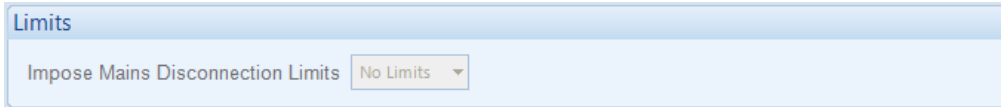

Parameter	Description
Impose Mains Disconnection Limits	<p><b>NOTE:</b> Category I to III Limits are only applicable for 60Hz nominal frequency. The <i>VDE-AR-N 4110:2018 Power generating unit limit</i> is only applicable to 50Hz.</p> <p>Limit the Mains Decoupling Alarms, options are:  <b>No Limits</b>  <b>Category I Limit</b>  <b>Category II Limit</b>  <b>Category III Limit</b>  <b>VDE-AR-N 4110:2018 Power generating unit</b></p>

#### Rate Of Change Of Frequency Alarm



Parameter	Function
R.O.C.O.F. Alarm Enable IEEE C37.2 - 81 Frequency relay	<p><input type="checkbox"/> = R.O.C.O.F. protection is disabled.</p> <p><input checked="" type="checkbox"/> = R.O.C.O.F. protection is enabled. The <i>R.O.C.O.F. Alarm</i> activates when the generator/Mains frequency changes faster than the configured <i>Trip</i> setting. The <i>R.O.C.O.F. Alarm</i> is only enabled when the generator is in parallel with the Mains supply, for a Multi-Set an input configured for <i>Mains Parallel Mode</i> must be active, for a Single Set the mains breaker must be closed.</p> <p>During an islanding event the island frequency changes rapidly as it's no longer linked to the grid, R.O.C.O.F detects this rapid change and disconnects the generator from the island.</p>

**Vector Shift Alarm**

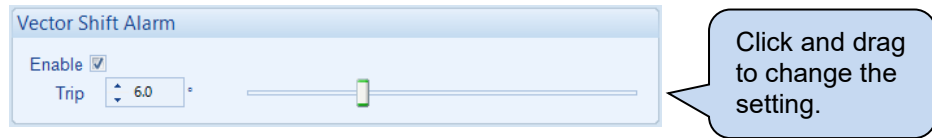

Parameter	Function
Vector Shift	<p><input type="checkbox"/> = Vector Shift protection is disabled</p> <p><input checked="" type="checkbox"/> = Vector Shift protection is enabled. The <i>Vector Shift Alarm</i> activates when the generator/Mains voltage vector changes by more than the <i>Trip</i> setting. The <i>Vector Shift Alarm</i> is only enabled when the generator is in parallel with the Mains supply, for a Multi-Set an input configured for Mains Parallel Mode must be active, for a Single Set the mains breaker must be closed.</p> <p>Vector Shift detection measures the length of each cycle of the voltage waveform. When the mains fails in parallel with the generator, the sudden change in load creates a change in the length of one cycle which is detected by this trip.</p>

**QU Var Voltage**

**NOTE:** The default setting for the timer when VDE-AR- N- 4110:2018 Power generating unit is selected is 0.5 seconds.

**NOTE:** For the alarm to trip the mains voltage must be below the threshold and the mains vars must be above the threshold and leading into the mains. Lagging vars support the grid so the alarm will not trip with any lagging vars into the grid.

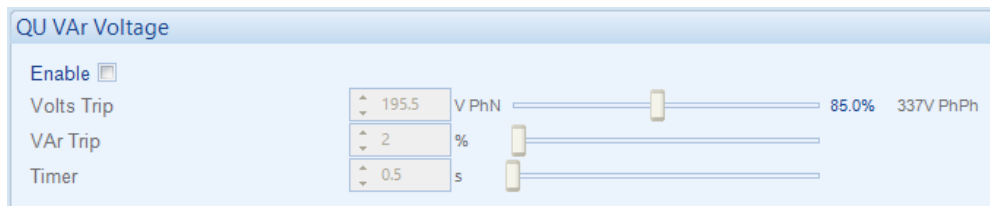

Parameter	Description
Enable	<p><input type="checkbox"/> = <i>QU Var Voltage</i> alarm is disabled</p> <p><input checked="" type="checkbox"/> = <i>QU Var Voltage</i> alarm is enabled</p>
Volts Trip	Set the threshold at which the QU var trips if it falls below this level.
Var Trip	Set the percentage threshold at which the var trips once it rises above this level.
Timer	Set the delay before the alarm is activated.

### 3.11 ENGINE

The *Engine* section is subdivided into smaller sections.  
Select the required section with the mouse.



### 3.11.1 ENGINE PROTECTION

#### Water in Fuel

Water In Fuel

Action: Warning

Arming: Always

Activation Delay: 0s

Parameter	Description
Action	<p>The alarm activates when a <i>Water in Fuel</i> alarm is received from the engine ECU, or if a digital input configured for <i>Water in Fuel</i> activates for longer than the configured <i>Activation Delay</i> timer.</p> <p>For more information see the section entitled <i>Alarm Types</i> elsewhere in this document.</p> <p>The alarm action list is as follows:</p> <p><b>None</b>  <b>Electrical Trip</b>  <b>Shutdown</b>  <b>Warning</b></p>
Arming	<p>Select when the alarm is active For further information see the section entitled <i>Alarm Arming</i> elsewhere in this document.</p> <p>The alarm arming list is as follows:</p> <p><b>Active from Breaker Closed</b>  <b>Active from Parallel</b>  <b>Always</b>  <b>From Safety On</b>  <b>From Starting</b>  <b>Never</b>  <b>When Stationary</b></p>

#### Fuel Tank Bund

Fuel Tank Bund

Action: Warning

Parameter	Description
Action	<p>The alarm goes active when a digital input configured for <i>Fuel Tank Bund Level High</i> activates</p> <p>The input is designed to connect to a level switch within the tank bund (sometimes known as the Fuel Retention Tank). This is used to detect fuel leaks and overflows.</p> <p>For more information see the section entitled <i>Alarm Types</i> elsewhere in this document.</p> <p>The alarm action list is as follows:</p> <p><b>Electrical Trip</b>  <b>Shutdown</b>  <b>Warning</b></p>

### 3.11.2 OIL PRESSURE

**NOTE:** The DSE module reads oil pressure from the ECU (ECM) if the selected Engine Application supports it. In these cases, Analogue Input A is configured as Flexible Analogue or Digital Input. Configuration of Flexible Analogue Inputs and Digital Inputs are detailed in sections entitled *Analogue Input Configuration & Digital Inputs* elsewhere in this document.

#### Input Type

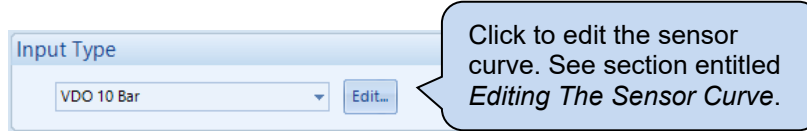

Parameter	Description
Input Type	Select the sensor type and curve from a pre-defined list or create a user-defined curve. <b>Resistive:</b> for sensors with maximum range of 0 $\Omega$ to 3 k $\Omega$ <b>Current:</b> for sensors with maximum range of 0 mA to 20 mA <b>Voltage:</b> for sensors with maximum range of 0 V to 10 V

### 3.11.2.1 EDITING THE OIL SENSOR CURVE

While the *DSE Configuration Suite* holds sensor specifications for the most used resistive sensors, occasionally it is required that the module be connected to a sensor not listed by the *DSE Configuration Suite*. To aid this process, a sensor curve editor is provided.

**Input Type**

VDO 10 Bar Edit...

The sensor curve that is to be used.

Click to edit the selected sensor curve or create a curve if a curve is not selected.

**Curve Editor**

Oil Pressure

Display Pressure in: Bar

The red highlighted area indicates under measurable range.

The red highlighted area indicates over measurable range.

Click to change the Y axis value between imperial and metric units.

Double click the left mouse button to add a point or right click on a point to remove it.

Click and drag the points on the graphs to change the settings

Use the mouse to select the graph point, then enter the value in the box or click up/down to change the value

Click *Interpolate* then select two points as prompted to draw a straight line between

Click to change the range of the X and Y Axes of the graph and the level of open circuit

Click Save As prompt to name the curve...

New Curve Name

Enter a name for the new curve

Click OK to save the curve.

Click OK to accept the changes or CANCEL to ignore and lose the

**Hint:** Deleting, renaming, or editing custom sensor curves that have been added is performed in the main menu, select *Tools | Curve Manager*.

Number of points used: 2/31

## Editing the Configuration

Select Range

Ohms	Bar
25	0.5
37.5	1.5
50	2.5
62.5	3.5
75	4.5
100	5.5
125	6.5
150	8.0
175	10.5
225	10.5

**X-Axis(Ohms)** Minimum: 0 Maximum: 240  
*X-Axis range must exceed 200 Ohms*

**Y-Axis(Bar)** Minimum: 0 Maximum: 17  
*Y-Axis range must exceed 2 Bar*

**X Axis - Fault Threshold** Minimum: 0 Maximum: 5000

OK Cancel

To change range values, enter the value in the box or click up/down to change the value

**Sensor Open Circuit Alarm**

Sensor Open Circuit Alarm

Enable Alarm

Parameter	Description
Enable Alarm	<input type="checkbox"/> = Alarm is disabled. <input checked="" type="checkbox"/> = The <i>Low Oil Pressure Open Circuit Alarm</i> is active when the module detects an open circuit when the sensor is disconnected.

**NOTE:** Open Circuit alarm is only available for resistive sensors. A Warning/Shutdown alarm must be enabled to enable this option.

**Low Oil Pressure Alarms**

Low Oil Pressure Alarms

Shutdown

Trip  Bar 103 kPa, 14.94 PSI

Pre-Alarm

Trip  Bar 124 kPa, 17.98 PSI

Return  Bar 138 kPa, 20.02 PSI

Parameter	Description
Low Oil Pressure Shutdown	<input type="checkbox"/> = Alarm is disabled. <input checked="" type="checkbox"/> = The <i>Low Oil Pressure Shutdown Alarm</i> is active when the measured oil pressure drops below the configured <i>Trip</i> level.
Low Oil Pressure Pre-Alarm	<input type="checkbox"/> = Alarm is disabled. <input checked="" type="checkbox"/> = The <i>Low Oil Pressure Pre-Alarm</i> is active when the measured oil pressure drops below the configured <i>Trip</i> level. The warning is automatically reset when the oil pressure increases above the configured <i>Return</i> level.

### 3.11.3 COOLANT TEMPERATURE

The *Coolant Temperature* page is subdivided into smaller sections. Select the required section with the mouse.

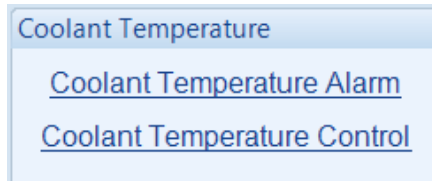

#### 3.11.3.1 COOLANT TEMPERATURE ALARM

**NOTE:** The DSE module reads oil pressure from the ECU (ECM) if the selected Engine Application supports it. In these cases, Analogue Input B is configured as Flexible Analogue or Digital Input. Configuration of Flexible Analogue Inputs and Digital Inputs are detailed in sections entitled *Analogue Input Configuration & Digital Inputs* elsewhere in this document.

#### Input Type



Parameter	Description
Input Type	<p>Select the sensor type and curve from a pre-defined list or create a user-defined curve.</p> <p><b>Resistive:</b> for sensors with maximum range of 0 <math>\Omega</math> to 3 k<math>\Omega</math></p> <p><b>Current:</b> for sensors with maximum range of 0 mA to 20 mA</p> <p><b>Voltage:</b> for sensors with maximum range of 0 V to 10 V</p>

### 3.11.3.2 EDITING THE COOLANT SENSOR CURVE

While the *DSE Configuration Suite* holds sensor specifications for the most used resistive sensors, occasionally it is required that the module be connected to a sensor not listed by the *DSE Configuration Suite*. To aid this process, a sensor curve editor is provided.

**Input Type**

VDO 120 °C Edit

The sensor curve that is to be used.

Click to edit the selected sensor curve or create a curve if a curve is not selected.

**Curve Editor**

<Unnamed Curve> Display Temperature in: °C

Click and drag the points on the graphs to change the settings

Click to change the Y axis value between imperial and metric units.

Double click the left mouse button to add a point or right click on a point to remove it.

Use the mouse to select the graph point, then enter the value in the box or click up/down to change the value

The red highlighted area indicates over/under measurable range.

Click *Interpolate* then select two points as prompted to draw a straight line between

Click to change the range of the X and Y Axes of the graph and the level of open circuit

Click Save As prompt to name the curve...

Click OK to accept the changes or CANCEL to ignore and lose the

Click OK to save the curve.

**Any saved curves become selectable in the *Input Type* selection list.**

Hint: Deleting, renaming, or editing custom sensor curves that have been added is performed in the main menu, select *Tools | Curve Manager*.

## Editing the Configuration

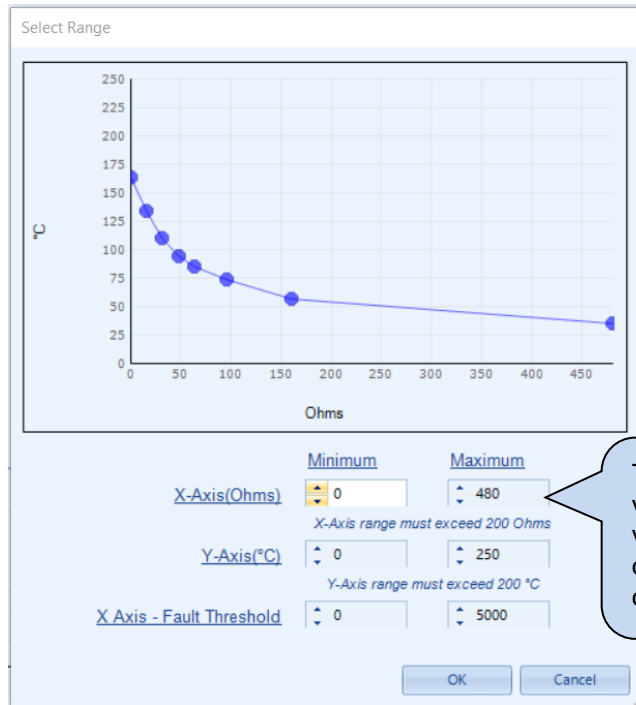

To change range values, enter the value in the box or click up/down to change the value

**Sensor Open Circuit Alarm**

Sensor Open Circuit Alarm

Enable Alarm

Parameter	Description
Enable Alarm	<input type="checkbox"/> = Alarm is disabled. <input checked="" type="checkbox"/> = The <i>Coolant Temperature Open Circuit Alarm</i> is active when the module detects an open circuit when the sensor is disconnected.

**Low Coolant Temperature Alarms**

Low Coolant Temperature Alarms

Pre-Alarm

Trip  °C 158 °F

Return  °C 167 °F

Parameter	Description
Low Coolant Temperature Pre-Alarm	<input type="checkbox"/> = Alarm is disabled. <input checked="" type="checkbox"/> = The <i>Low Coolant Temperature Pre-Alarm</i> is active when the measured coolant temperature falls below the configured <i>Trip</i> level. The <i>Warning</i> is automatically reset when the coolant temperature rises above the configured <i>Return</i> level.

**High Coolant Temperature Alarms**

High Coolant Temperature Alarms

Pre-Alarm

Return  °C 190 °F

Trip  °C 194 °F

Electrical Trip

Trip  °C 198 °F

Shutdown

Trip  °C 203 °F

Parameter	Description
High Coolant Temperature Pre-Alarm	<input type="checkbox"/> = Alarm is disabled. <input checked="" type="checkbox"/> = The High Coolant Temperature Pre-Alarm is active when the measured coolant temperature rises above the configured Trip level. The Warning is automatically reset when the coolant temperature falls below the configured Return level.
High Coolant Temperature Electrical Trip	<input type="checkbox"/> = Alarm is disabled. <input checked="" type="checkbox"/> = The High Coolant Temperature Controlled Shutdown Alarm is active when the measured coolant temperature rises above the configured Trip level.
High Coolant Temperature Shutdown	The High Coolant Temperature Shutdown Alarm is active when the measured coolant temperature rises above the configured Trip level.

### 3.11.3.3 COOLANT TEMPERATURE CONTROL

#### Coolant Heater Control

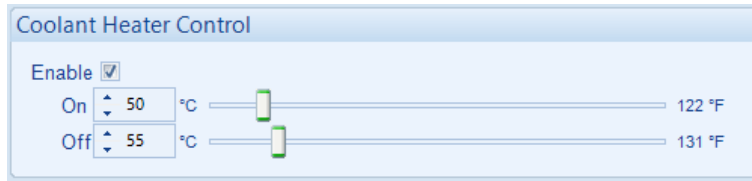

Parameter	Description
Coolant Heater Control	<input type="checkbox"/> = Coolant Heater Control function is disabled. <input checked="" type="checkbox"/> = The digital output configured to <i>Coolant Heater Control</i> is energised when the engine coolant temperature falls below the configured <i>On</i> level. This is designed to control an external engine heater. When the coolant temperature rises above the configured <i>Off</i> level, the digital output is de-energised.

#### Coolant Cooler Control

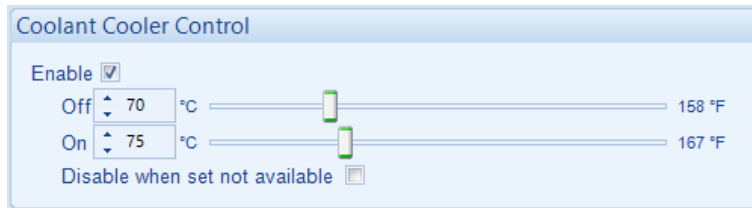

Parameter	Description
Coolant Cooler Control Enable	<input type="checkbox"/> = Coolant Cooler Control function is disabled. <input checked="" type="checkbox"/> = The digital output configured to <i>Coolant Cooler Control</i> is energised when the engine coolant temperature exceeds the configured <i>On</i> level. This is designed to control an external engine cooling system, for instance an additional cooling fan. When the coolant temperature falls below the configured <i>Off</i> level, the digital output is then de-energised.

#### Fan Control

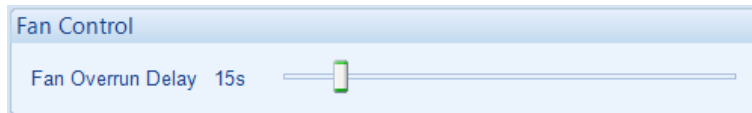

Parameter	Description
Fan Control	An output configured to <i>Fan Control</i> energises when the engine becomes available (up to speed). This output is designed to control an external cooling fan. When the engine stops, the cooling fan remains running for the duration of the <i>Fan Overrun Delay</i> .

### **3.11.4 FUEL LEVEL**

The *Fuel Level* page is subdivided into smaller sections.  
Select the required section with the mouse.

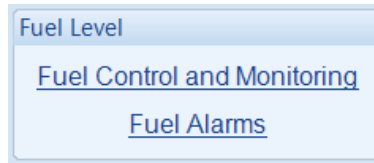

### 3.11.4.1 FUEL CONTROL AND MONITORING

#### Input Type

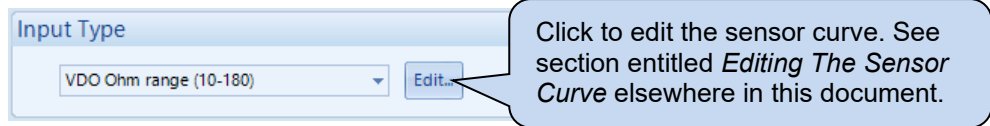

Parameter	Description
Input Type	Select the sensor type and curve from a pre-defined list or create a user-defined curve <b>Resistive:</b> for sensors with maximum range of 0 $\Omega$ to 3 k $\Omega$ <b>Current:</b> for sensors with maximum range of 0 mA to 20 mA <b>Voltage:</b> for sensors with maximum range of 0 V to 10 V

### 3.11.4.2 CREATING/EDITING FUEL CONTROL & MONITORING SENSOR

While the *DSE Configuration Suite* holds sensor specifications for the most used resistive sensors, occasionally it is required that the module be connected to a sensor not listed by the *DSE Configuration Suite*. To aid this process, a sensor curve editor is provided.

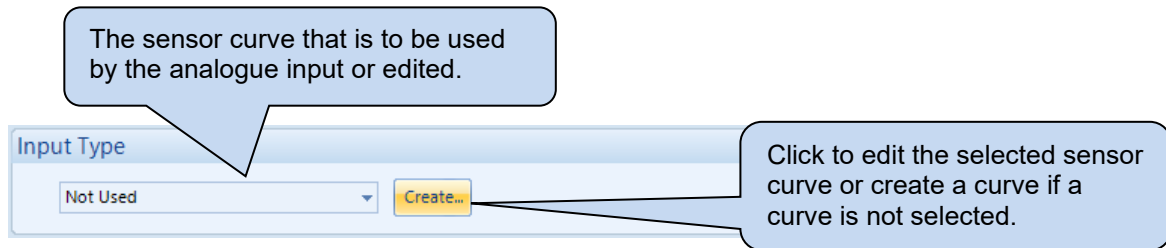

When creating a new sensor curve the measurement quantity and measured parameter are required.

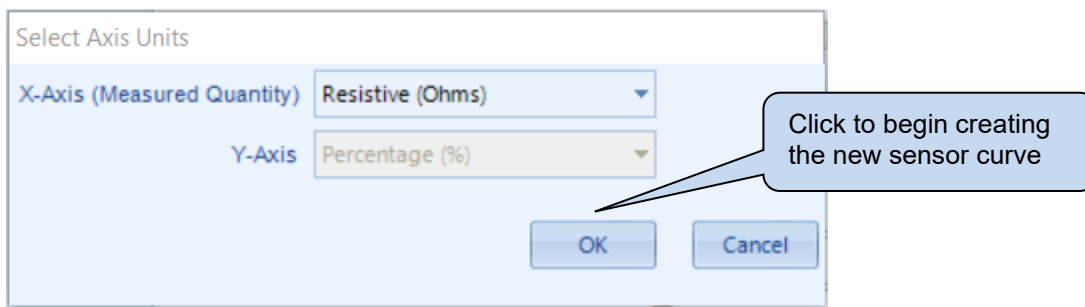

Parameter	Description
X-Axis (Measured Quantity)	Select the electrical quantity that the sensor outputs. <b>Current (mA):</b> For sensors that output current within a range 0 mA to 20 mA <b>Voltage (0-10 Volts):</b> For sensors that output voltage within a range of 0 V to 10 V <b>Voltage (0-32 Volts):</b> For sensors that output voltage within a range of 0 V to 32 V <b>Resistive (Ohms):</b> For sensors that output a resistance within a range 0 Ω to 3K Ω on Analogue Input A and 0 to 5K Ω on Analogue Inputs B to G
Y-Axis	Select the parameter that is being monitored by the sensor. <b>Temperature (°C):</b> For sensors that measure temperature. <b>Pressure (Bar):</b> For sensors that measure pressure. <b>Percentage (%):</b> For sensors that measure percentage.

Sensor curve creation and editor descriptions are continued overleaf...

## Editing the Configuration

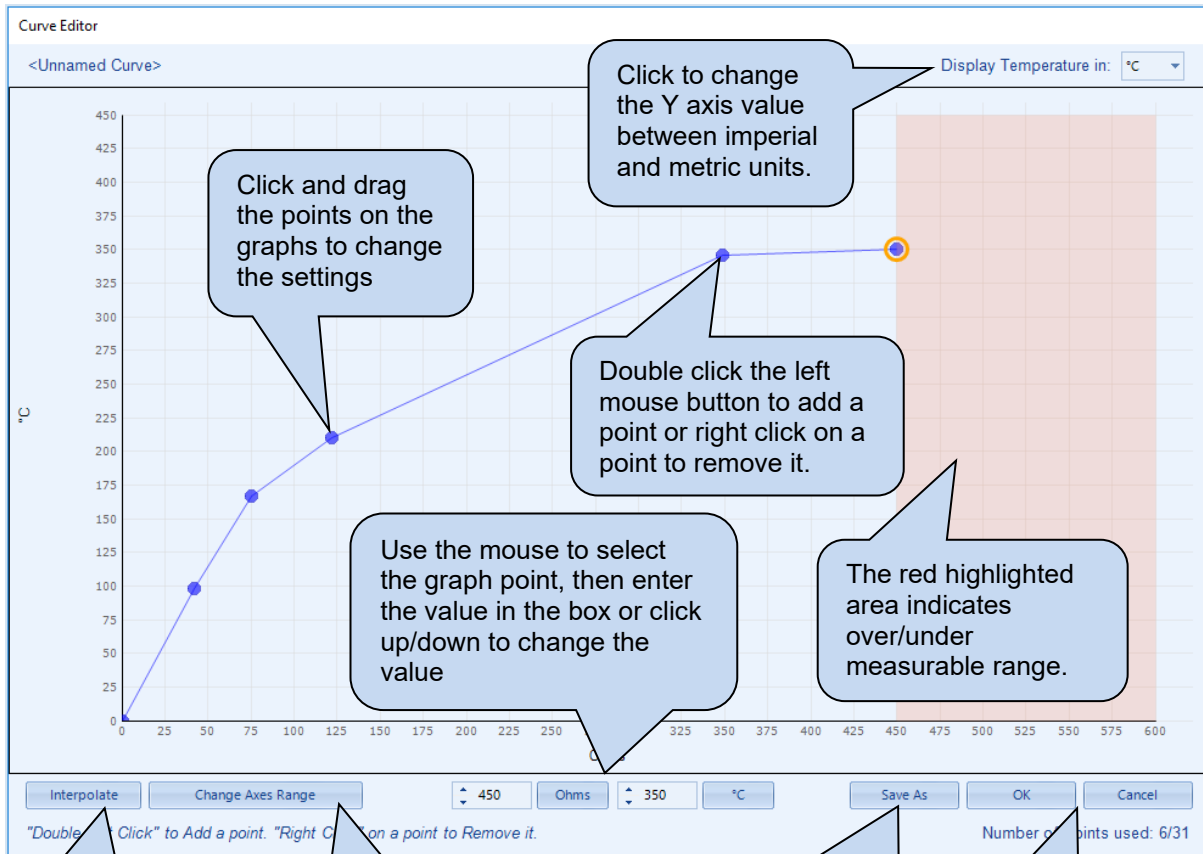

Click *Interpolate* then select two points as prompted to draw a straight line between

Click to change the range of the X and Y Axes of the graph and the level of open circuit

Click Save As prompt to name the curve...

New Curve Name

Enter a name for the new curve

OK Cancel

Click OK to accept the changes or CANCEL to ignore and lose the

Click OK to save the curve.

**Any saved curves become selectable in the *Input Type* selection list.**

**Hint:** Deleting, renaming, or editing custom sensor curves that have been added is performed in the main menu, select *Tools | Curve Manager*.

## Editing the Configuration

Select Range

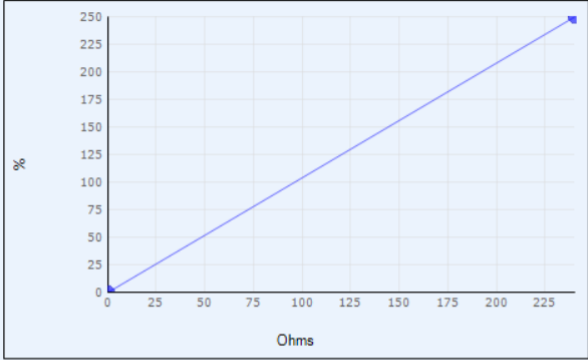

Minimum Maximum

X-Axis(Ohms) 0 240  
*X-Axis range must exceed 200 Ohms*

Y-Axis(%) 0 250  
*Y-Axis range must exceed 200 %*

X Axis - Fault Threshold 0 5000

OK Cancel

To change range values, enter the value in the box or click up/down to change the value

**Accurate Fuel Measurement**

In the case of a parallel sided fuel tank, an accurate measure of the fuel level is easily made, however this is not the case with non-parallel sided fuel tanks. Alteration to the fuel level sensor curve is required for non-parallel sided to attain more accurate level indication. This is because a fuel level sensor measures the distance between the top of the tank and the fuel level.

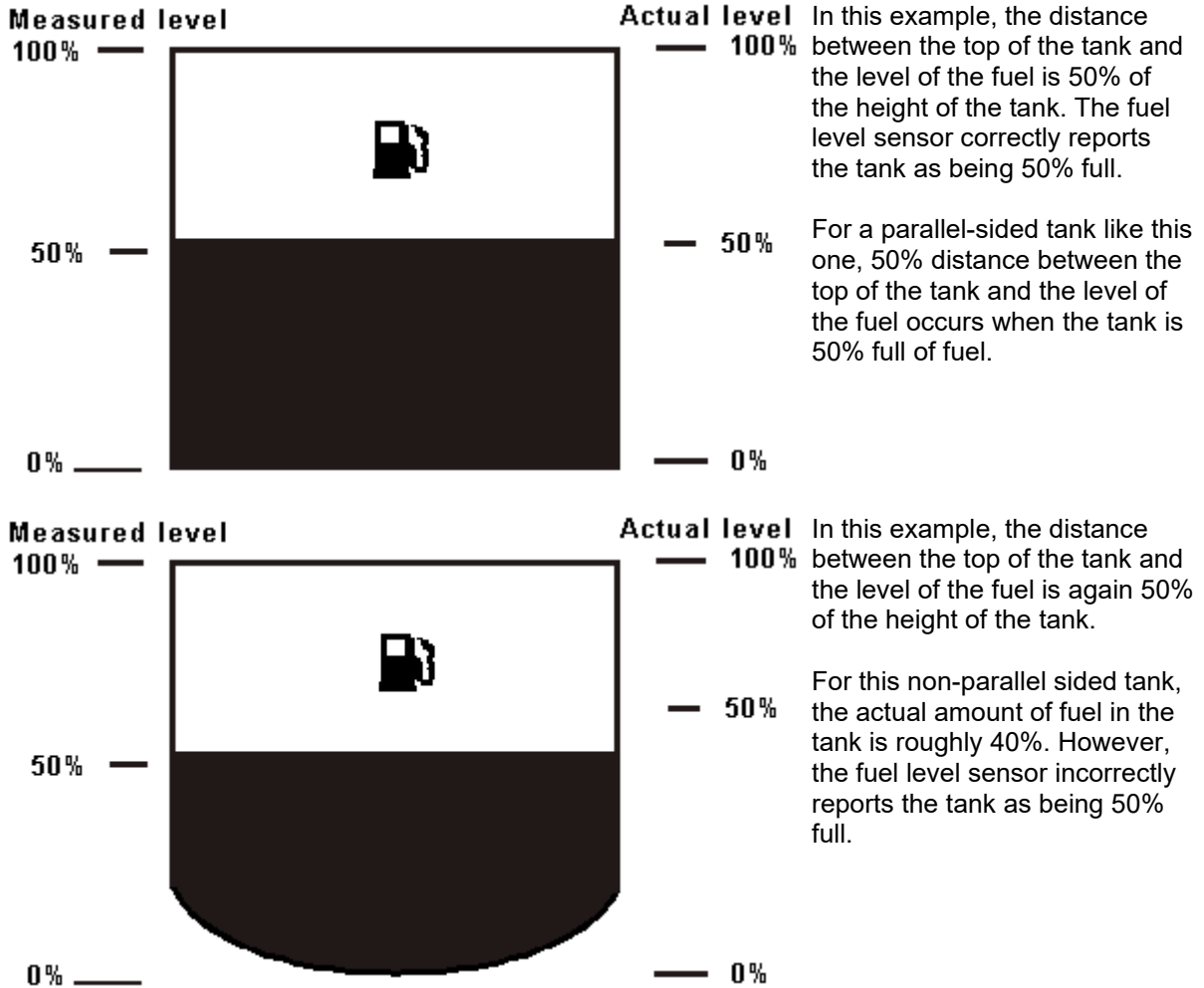

**Fuel Pump Control**

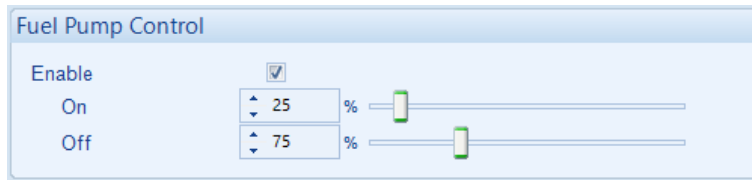

Parameter	Description
Fuel Pump Control Enable	<p><input type="checkbox"/> = Fuel Pump Control is disabled.</p> <p><input checked="" type="checkbox"/> = Allows the module to control an external fuel pump to transfer fuel from a bulk tank to the day tank.</p> <p>A digital output configured for <i>Fuel Pump Control</i> energises when the fuel level falls below the configured <i>On</i> setting and de-energises when the fuel level exceeds the configured <i>Off</i> setting.</p>

**Fuel Monitoring**

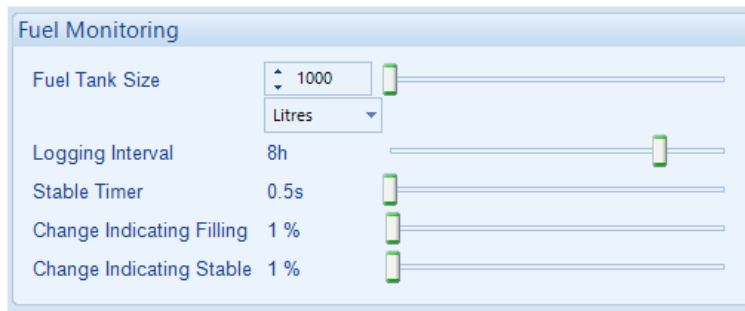

Parameter	Description
Fuel Tank Size	Select the tank size and the units for the module's display: <b>Imperial Gallons</b> <b>Litres</b> <b>US Gallons</b>
Logging Interval	The interval at which the fuel level is stored in the event log.
Stable Timer	The controller maintains a rolling record of the fuel level percentage for the duration of the <i>Stable Timer</i> .  When the rolling record of the fuel level percentage indicates that the fuel level has increased more than the <i>Change Indicating Filling</i> during the <i>Stable Timer</i> , the controller records a <i>Fuel Filling Start</i> event in its event log.  When the rolling record of the fuel level indicates that the fuel level has not changed more than the <i>Change Indicating Stable</i> during the <i>Stable Timer</i> , the controller records a <i>Fuel Filling Stop</i> event in its event log.
Change Indicating Filling	When the fuel level increases at a rate higher than  <b><u>Change Indicating Filling</u></b> <i>Stable Timer</i>  Then a fuel fill start event is recorded into the event log.  <b>Example</b> <i>Stable Timer</i> = 1 minute <i>Change Indicating Filling</i> = 3 %  When the fuel level increases by more than 3% in 1 minute, a fuel fill event is recorded.
Change Indicating Stable	During filling if the fuel level increases at a rate less than  <b><u>Change Indicating Stable</u></b> <i>Stable Timer</i>  then a fuel fill end event is recorded into the event log. Depending on configuration this generates a dial out or SMS message.  <b>Example:</b> <i>Stable Timer</i> = 1 minute <i>Change Indicating Stable</i> = 2 %  When the fuel level increases by less than 2% in 1 minute, a fuel fill end event is recorded.

### 3.11.4.3 FUEL ALARMS

#### Sensor Open Circuit Alarm

**Sensor Open Circuit Alarm**

Enable Alarm

Parameter	Description
Enable Alarm	<input type="checkbox"/> = Alarm is disabled. <input checked="" type="checkbox"/> = The <i>Open Circuit Alarm</i> activates with the configured

#### Low Fuel Level Alarms

**Low Fuel Level Alarms**

Alarm

Action Shutdown ▾

Trip 25 %

Delay 0s

Pre-Alarm

Trip 30 %

Return 40 %

Delay 0s

Parameter	Description
Low Fuel Level Alarm	<input type="checkbox"/> = Alarm is disabled. <input checked="" type="checkbox"/> = The <i>Low Fuel Level Alarm</i> activates with the configured <i>Action</i> when the measured fuel level drops below the <i>Trip</i> setting for the configured <i>Delay</i> time.
Action	<p><b>⚠ NOTE: For details of these, see the section entitled <i>Alarm Types</i> elsewhere in this document.</b></p> <p>Select the type of alarm required from the list:  <b><i>Electrical Trip</i></b>  <b><i>Shutdown</i></b></p>
Low Fuel Level Pre-Alarm	<input type="checkbox"/> = Alarm is disabled. <input checked="" type="checkbox"/> = The <i>Low Fuel Level Pre-Alarm</i> activates with the configured <i>Action</i> when the measured fuel level drops below the <i>Low Pre-Alarm Trip</i> setting for the configured <i>Delay</i> time. The Pre-Alarm is automatically reset when the fuel level exceeds the configured <i>Low Pre-Alarm Return</i> setting.

**High Fuel Level Alarms**

Parameter	Description
High Fuel Level Pre-Alarm	<input type="checkbox"/> = Alarm is disabled. <input checked="" type="checkbox"/> = The <i>High Fuel Level Pre-Alarm</i> activates with the configured <i>Action</i> when the measured fuel level rises above the <i>High Pre-Alarm Trip</i> setting for the configured <i>Delay</i> time. The pre-alarm is automatically reset when the fuel level drops below the configured <i>High Pre-Alarm Return</i> setting.
High Fuel Level Alarm	<input type="checkbox"/> = Alarm is disabled. <input checked="" type="checkbox"/> = The <i>High Fuel Level Alarm</i> activates with the configured <i>Action</i> when the measured fuel level raises above the <i>Trip</i> setting for the configured <i>Delay</i> time.
Action	<div style="border: 1px solid black; padding: 5px;"> <p><b>NOTE:</b> For details of these, see the section entitled <i>Alarm Types</i> elsewhere in this document.</p> </div> <p>Select the type of alarm required from the list:  <b>Electrical Trip</b>  <b>Shutdown</b></p>

**Fuel Usage Alarm**

Parameter	Description
Fuel Usage Alarm Enable	<input type="checkbox"/> = Alarm is disabled. <input checked="" type="checkbox"/> = Provides an alarm to monitor the usage of the fuel. The alarm activates when the fuel level drops at a higher rate than the configured <i>Running Rate</i> while the engine is running. Or if the fuel level drops at a higher rate than the configured <i>Stopped Rate</i> while the engine is stopped. This alarm is provided to check for fuel leakage problems or potential fuel theft.
Mode	<p><b>Sampling Window:</b> The fuel usage alarm activates when the fuel level decreases at a higher rate per <i>Sampling Window</i> than the configured <i>Running Rate</i> while the engine is running or <i>Stopped Rate</i> while the engine is stopped.</p> <p><b>Standard Mode:</b> The fuel usage alarm activates when the fuel level decreases at a higher rate per hour than the configured <i>Running Rate</i> while the engine is running or <i>Stopped Rate</i> while the engine is stopped.</p>
Action	The alarm action list is as follows, see the section entitled <i>Alarm Types</i> for more information:  <b>Electrical Trip</b> <b>Latched Indication</b> <b>Shutdown</b> <b>Warning Always Latched</b>

### 3.11.5 FUEL USE AND EFFICIENCY

#### Engine Efficiency Curve

Parameter	Description
Engine Type	Select the engine type from a pre-defined list or create a user-defined curve.
Specific Gravity	The relative fuel density of the fuel (usually given as kg/m <sup>3</sup> ) being consumed by the generator.

#### Instrumentation Sources

Parameter	Description
Instantaneous Fuel Consumption	<b>Not Used:</b> <i>Instantaneous Fuel Consumption</i> is not displayed <b>Efficiency Curve:</b> The DSE module calculates the <i>Instantaneous Fuel Consumption</i> as Litre/hour from <i>Generator Total kW Percentage</i> using the <i>Efficiency Curve</i> and <i>Specific Gravity</i> . <b>Engine ECU:</b> The DSE module reads the <i>Instantaneous Fuel Consumption</i> as Litre/hour from the engine ECU.
Trip Average Fuel Consumption	<b>Not Used:</b> <i>Trip Average Fuel Consumption</i> is not displayed <b>Efficiency Curve:</b> The DSE module calculates the <i>Trip Average Fuel Consumption</i> as litre/hour over the current or last run from <i>Generator Total kW Percentage</i> using the <i>Efficiency Curve</i> and <i>Specific Gravity</i> . <b>Engine ECU:</b> The DSE module reads the <i>Trip Average Fuel Consumption</i> as litre/hour over the current or last run from the engine ECU. <b>Module Sensor:</b> The DSE module calculates the <i>Trip Average Fuel Consumption</i> as litre/hour over the current or last run from the change in fuel tank level using the <i>Fuel Tank Size</i> .
Trip Fuel Usage	<b>Not Used:</b> <i>Trip Fuel Usage</i> is not displayed <b>Efficiency Curve:</b> The DSE module calculates the <i>Trip Fuel Usage</i> as litres over the current or last run from <i>Generator Total kW Percentage</i> using the <i>Efficiency Curve</i> and <i>Specific Gravity</i> . <b>Engine ECU:</b> The DSE module reads the <i>Trip Fuel Usage</i> as litres over the current or last run from the engine ECU. <b>Module Sensor:</b> The DSE module calculates the <i>Trip Fuel Usage</i> as litres over the current or last run from the change in fuel tank level using the <i>Fuel Tank Size</i> .

Parameter descriptions are continued overleaf...

Parameter	Description
Accumulated Fuel Usage	<p><b>Not Used:</b> <i>Accumulated Fuel Usage</i> is not displayed.</p> <p><b>Efficiency Curve:</b> The DSE module calculates the <i>Accumulated Fuel Usage</i> as litres over the entire run time from <i>Generator Total kW Percentage</i> using the <i>Efficiency Curve</i> and <i>Specific Gravity</i>.</p> <p><b>Engine ECU:</b> The DSE module reads the <i>Accumulated Fuel Usage</i> as litres over the entire run time from the engine ECU.</p> <p><b>Module Sensor:</b> The DSE module calculates the <i>Accumulated Fuel Usage</i> as litres over the entire run time from the change in fuel tank level using the <i>Fuel Tank Size</i>.</p>
Instantaneous Efficiency	<p><b>Not Used:</b> <i>Instantaneous Efficiency</i> is not displayed.</p> <p><b>Efficiency Curve:</b> The DSE module calculates the <i>Instantaneous Efficiency</i> as kWh/litre from <i>Generator Total kW Percentage</i> using the <i>Efficiency Curve</i> and <i>Specific Gravity</i>.</p> <p><b>Engine ECU:</b> The DSE module reads the <i>Instantaneous Fuel Consumption</i> as Litre/hour from the engine ECU and calculates the <i>Instantaneous Efficiency</i> as kWh/litre using the <i>Generator Total kW Percentage</i>.</p>
Trip Average Efficiency	<p><b>Not Used:</b> <i>Trip Average Efficiency</i> is not displayed.</p> <p><b>Efficiency Curve:</b> The DSE module calculates the <i>Trip Average Efficiency</i> as kWh/litre over the current or last run from <i>Generator Total kW Percentage</i> using the <i>Efficiency Curve</i> and <i>Specific Gravity</i>.</p> <p><b>Engine ECU:</b> The DSE module reads the <i>Trip Average Fuel Consumption</i> as Litre/hour from the engine ECU over the current or last run and calculates the <i>Trip Average Efficiency</i> as kWh/litre using the <i>Generator Total kW Percentage</i>.</p> <p><b>Module Sensor:</b> The DSE module calculates the <i>Trip Average Efficiency</i> as kWh/litre over the current or last run from the change in fuel tank level using the <i>Fuel Tank Size</i> and <i>Generator Total kW Percentage</i>.</p>
Estimate Run Time to Empty	<p><b>Not Used:</b> <i>Estimate Run Time to Empty</i> is not displayed.</p> <p><b>Engine ECU:</b> The DSE module reads the <i>Instantaneous Fuel Consumption</i> as Litre/hour from the engine ECU and <i>Estimates Run Time to Empty</i> using the <i>Fuel Tank Size</i>.</p> <p><b>Module Sensor:</b> The DSE module <i>Estimates Run Time to Empty</i> using the <i>Run Time Until Empty</i> parameters.</p>

### Run Time Until Empty

The screenshot shows a configuration window titled "Run Time Until Empty". It contains two sliders with numerical input fields and unit indicators. The first slider, "Fuel Tank Run Time", has a value of 480 and a unit of "m" (minutes). The second slider, "Fuel Tank Run Time Load Level Percentage", has a value of 100 and a unit of "%". The maximum value for the first slider is indicated as "8h 0m".

Parameter	Description
Fuel Tank Run Time	The time in minutes how long the generator's fuel tank last when running at the <i>Fuel Tank Run Time Load Level Percentage</i> .
Fuel Tank Run Time Load Level Percentage	The percentage of full load kW the generator which is used to calculate how long the fuel in the tank lasts.

### 3.11.6 DEF LEVEL

**NOTE:** Configuration of alarms in this section only has effect when the ECU (ECM) supports DEF Level.

**NOTE:** Configuration of the *Alarm Action* in this section defines the DSE module response to the CANbus message; however, the ECU (ECM) still shuts down the engine depending on the alarm severity.

DEF Level is a CANbus message from the ECU (ECM). The following parameters allow configuration of how the DSE module responds to the DEF Level.

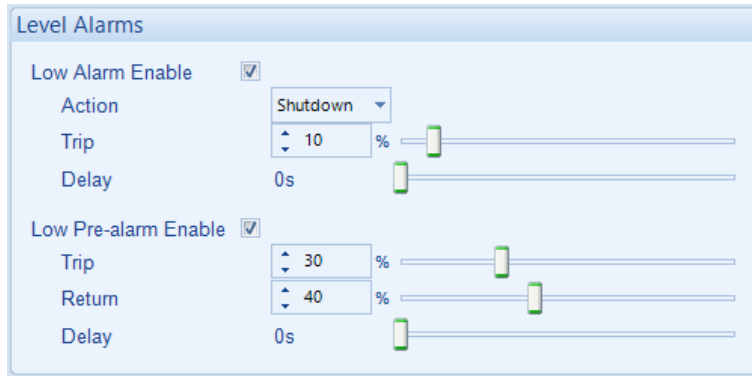

Parameter	Description
DEF Level Low Alarm Enable	<input type="checkbox"/> = Disable the alarm. <input checked="" type="checkbox"/> = <i>DEF Low Alarm</i> is activated when the <i>DEF Level</i> sent from the ECU is below the configured <i>Trip</i> level for longer than the configured <i>Delay</i> time.
Action	Select the type of alarm required from the list:  <b>Electrical Trip</b> <b>Shutdown</b> For details of these, see the section entitled <i>Alarm Types</i> elsewhere in this document.
DEF Level Low Pre-Alarm	<input type="checkbox"/> = The Pre-alarm is disabled. <input checked="" type="checkbox"/> = <i>DEF Low Pre-Alarm</i> is activated when the <i>DEF Level</i> sent from the ECU is below the configured <i>Trip</i> level for longer than the configured <i>Delay</i> time. The Pre-Alarm is deactivated when the <i>DEF Level</i> rises above the <i>Return</i> level.

### 3.11.7 ENGINE OPTIONS

#### ECU (ECM) Options

**ECU (ECM) Options**

Engine Type	Cummins CM2250
Enhanced J1939	<input type="checkbox"/>
Alternative Engine Speed	<input type="checkbox"/>
Modbus Engine Comms Port	RS485 Port
Disable ECM Speed Control	<input type="checkbox"/>

These items are read only and not adjustable. To change these items, visit the *Module | Application* menu.

Parameter	Description
Disable ECM Speed Control	Disables speed control by the DSE module. Useful when an external device (i.e., remote speed potentiometer) is used to control engine speed.

#### Miscellaneous Options

**Miscellaneous Options**

J1939-75 Instrumentation Enable	<input checked="" type="checkbox"/>
J1939-75 Alarms Enable	<input checked="" type="checkbox"/>
CAN source address (instrumentation)	44

Parameter	Description
J1939-75 Instrumentation Enable	Allows the DSE module to be interrogated by another CAN device and transfer the generator set instrumentation over J1939 link.
J1939-75 Alarms Enable	Allows the DSE module to be interrogated by another CAN device and transfer the alarms over J1939 link.
CAN Source Address (Instrumentation)	Set the <i>CAN Source Address</i> for the DSE module over which other CANbus devices read the generator set instrumentation.

#### Startup Options

**Startup Options**

Start Attempts	3
----------------	---

Parameter	Description
Start Attempts	<p>The number of starting attempts the module makes. If the module does not detect that the engine has fired before the end of the <i>Cranking Time</i>, then the current start attempt is cancelled, and the <i>Crank Rest</i> time takes place before the next crank attempt begins. If, after all configured <i>start attempts</i>, the engine is not detected as running, the <i>Fail to Start</i> shutdown alarm is generated.</p> <p>The engine is detected as running by checking all methods of <i>Crank Disconnect</i>. For further details, see the section entitled <i>Cranking</i> elsewhere in this document.</p>

**Pre-heat**

**NOTE:** For this feature to have effect, configure a digital output for *Pre-Heat*.

**NOTE:** Depending on *Engine Type* configuration, this is controlled direct by the ECU (ECM).

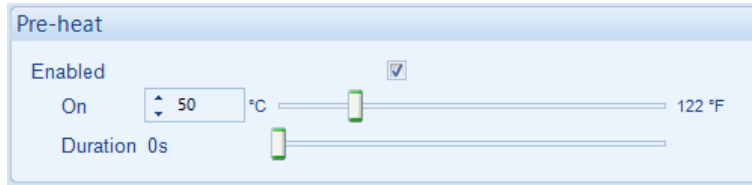

Parameter	Description
Enabled	<input type="checkbox"/> = Pre-heat is not temperature dependent. <input checked="" type="checkbox"/> = When the <i>Coolant Temperature</i> is below the configured <i>On</i> level, the <i>Pre-Heat</i> digital output is activated for the set <i>Duration</i> of time before cranking.
On	Set the coolant temperature below which the pre-heat is activated.
Duration	Set the time delay during which the <i>Pre-Heat</i> digital output remains active before cranking.

**Post-heat**

**NOTE:** For this feature to have effect, configure a digital output for *Pre-Heat*.

**NOTE:** Depending on *Engine Type* configuration, this is directly controlled by the ECU (ECM).

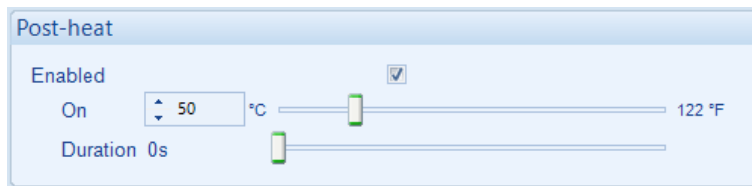

Parameter	Description
Enabled	<input type="checkbox"/> = Post-heat is not temperature dependent. <input checked="" type="checkbox"/> = When the <i>Coolant Temperature</i> is below the configured <i>On</i> level, the <i>Pre-Heat</i> digital output is activated for the set <i>Duration</i> of time after cranking and before the set is considered available.
On	Set the coolant temperature below which the pre-heat is activated.
Duration	Set the time delay during which the <i>Pre-Heat</i> digital output remains active after cranking and before the engine is considered available.

**NOTE:** A Duration Timer is used on both *Pre-heat* prior to the engine starting and *Post-heat* when the engine is considered available.

### 3.11.8 ECU (ECM) OPTIONS

#### Engine Hours

Engine Hours

Module to Record Engine Hours

Parameter	Description
Module to Record Engine Hours	When enabled, DSE module counts Engine Run Hours. When disabled, Engine ECU (ECM) provides Run Hours.

#### DPF Regeneration Control

DPF Regeneration Control

Allow Non-Mission Regeneration

Parameter	Description
DPF Regeneration Control	Available for ECUs (ECM) which require the engine speed to drop during a manual regeneration cycle. During this time, the generator is not available to supply power and the under speed and under frequency alarms are not active.

#### Speed Switch

Speed Switch

Enable Default Dataset ECU ▾

Parameter	Description
Speed Switch	Defines the method of speed control over CANbus when supported by the ECU (ECM). Selection needs to match the ECU (ECM) calibration for the speed control method. Available speed control methods to choose from: <b>0: Default Dataset ECU</b> <b>1: ECU Increase Decrease Input</b> <b>2: CAN Open Increase Decrease</b> <b>3: ECU Analogue Absolute</b> <b>4: ECU Analogue Relative</b> <b>5: ECU Frequency Input</b> <b>6: ECU CANopen Analogue</b> <b>7: CANopen Speed Demand</b>

Continued Overleaf...

## Editing the Configuration

### Example:

For some Volvo *Engine Types*, the *Speed Switch* indicates specific options as shown below.

Parameter	Description
Speed Switch Enable	<p>Defines the method of speed control over CANbus when supported by the Volvo ECU (ECM). Selection needs to match the ECU (ECM) calibration for the speed control method.</p> <p>Available speed control methods to choose from:</p> <p><b>Always</b></p> <p><b>Never</b></p> <p><b>On Change</b></p>

### ECU Wakeup

Parameter	Description
ECU Wakeup Enable	<p><input type="checkbox"/> = Option is disabled.</p> <p><input checked="" type="checkbox"/> = The ECU is energised for either 2 minutes (ECU wakeup time) or 10 seconds after the ECU coolant temperature measurement has been received, whichever is shorter.</p>
Coolant Measurement Persistence	<p><b>⚠ NOTE: Available only when <i>ECU Wakeup</i> is enabled.</b></p> <p><input type="checkbox"/> = Option is disabled.</p> <p><input checked="" type="checkbox"/> = The <i>Coolant Temperature</i> measurement is used for the <i>Coolant Temperature Control</i>.</p>

### Engine CAN Termination

Parameter	Description
Engine CAN Termination Disable	<p><input type="checkbox"/> = The internal resistor of 120 Ω is connected when the unit is powered.</p> <p><input checked="" type="checkbox"/> = The internal 120 Ω termination resistor is disabled, one must be fitted across the H and L terminals if the module is the first or last on the link.</p>

**Droop**

Parameter	Description
Droop	<p><b>NOTE:</b> Droop options are only available when they are supported by the Engine ECU (ECM) over the CAN or Modbus datalink. Contact the engine manufacturer for further details.</p> <p><input type="checkbox"/> = Engine droop is not enabled.  <input checked="" type="checkbox"/> = Where supported by the electronic engine ECU (ECM), the module enables droop in the engine ECU (ECM) governor at the configured percentage.</p>

**SPN Ignore List**

Parameter	Description
SPN Ignore List	<p>Choose the specific SPN for the module to ignore. The module allows the engine to keep running when the ignored SPN occurs; however, depending on the severity, the engine shuts down based on the ECU (ECM) calibration.</p> <p>This is used to mask certain indications or warnings on the ECU (ECM) and not display them on the DSE module.</p>

**Miscellaneous**

Parameter	Description
CAN Source Address (Engine Messages)	Set the CAN Source Address for the DSE module over which other CANbus devices read the modules data

### 3.11.9 ECU (ECM) ALARMS

**NOTE:** This section is only available when the module is connected to an ECU.

The *ECU (ECM) Alarms* section is subdivided into smaller sections. Select the required section with the mouse.

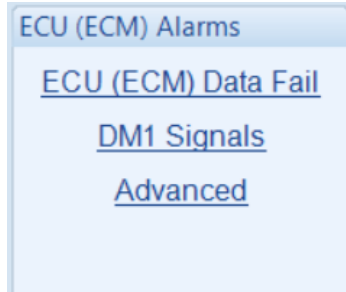

#### 3.11.9.1 ECU (ECM) DATA FAIL

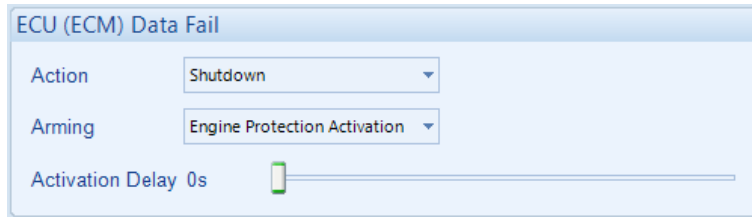

Parameter	Description
ECU (ECM) Data Fail Action	<p>Provides protection against failure of the ECU (ECM) CAN data link.</p> <p>The alarm action list is as follows, for more information see the section entitled <i>Alarm Types</i> elsewhere in this document:</p> <p><b>None</b>  <b>Electrical Trip</b>  <b>Shutdown</b>  <b>Warning</b></p>
Arming	<p>Select when the <i>CAN ECU (ECM) Data Fail</i> alarm is active.</p> <p>Options are as follows, for more information see the section entitled <i>Alarm Arming</i> elsewhere in this document:</p> <p><b>Active From Breaker Closed</b>  <b>Active From Mains Parallel</b>  <b>Always</b>  <b>From Safety On</b>  <b>From Starting</b>  <b>Never:</b>  <b>When Stationary</b></p>
Activation Delay	<p>The amount of time before the module activates the <i>CAN ECU (ECM) Data Fail</i> after a failure.</p>

### 3.11.9.2 DM1 SIGNALS

**NOTE:** Configuration of parameters in this section only has effect when the ECU (ECM) supports these features.

**NOTE:** Configuration of the *Alarm Action* in this section defines the DSE module response to the CAN message; however, the ECU (ECM) still shuts down the engine depending on the alarm severity.

DM1 signals are messages from the CAN (ECM) ECU. The following parameters allows configuration of how the DSE module responds to these messages.

#### ECU Amber

The screenshot shows a configuration window titled "ECU Amber". It contains three settings:

- Action:** A dropdown menu currently set to "Warning".
- Arming:** A dropdown menu currently set to "Always".
- Activation Delay:** A slider control set to "0s".

Parameter	Description
ECU Amber Action	<p>The action the DSE module takes when receiving and ECU Amber fault condition. The alarm action list is as follows, for more information see the section entitled <i>Alarm Types</i> elsewhere in this document:</p> <p><b>None</b> <b>Electrical Trip</b> <b>Shutdown</b> <b>Warning</b></p>
Arming	<p>Select when the DSE module activates it <i>ECU Amber</i> alarm. Options are as follows, for more information see the section entitled <i>Alarm Arming</i> elsewhere in this document:</p> <p><b>Active From Breaker Closed</b> <b>Active From Mains Parallel</b> <b>Always</b> <b>From Safety On</b> <b>From Starting</b> <b>Never:</b> <b>When Stationary</b></p>
Activation Delay	<p>The amount of time before the module activates the <i>ECU Amber</i> alarm after a receiving an ECU Amber fault condition from the ECU.</p>

**ECU Red**

ECU Red

Action Shutdown

Arming From Safety On

Activation Delay 0s

Parameter	Description
ECU Red Action	<p>The action the DSE module takes when receiving an ECU Red fault condition. The alarm action list is as follows, for more information see the section entitled <i>Alarm Types</i> elsewhere in this document:</p> <p><b>None</b> <b>Electrical Trip</b> <b>Shutdown</b> <b>Warning</b></p>
Arming	<p>Select when the DSE module activates its <i>ECU Red</i> alarm. Options are as follows, for more information see the section entitled <i>Alarm Arming</i> elsewhere in this document:</p> <p><b>Active From Breaker Closed</b> <b>Active From Mains Parallel</b> <b>Always</b> <b>From Safety On</b> <b>From Starting</b> <b>Never:</b> <b>When Stationary</b></p>
Activation Delay	<p>The amount of time before the module activates the <i>ECU Red</i> alarm after receiving an ECU Red fault condition from the ECU.</p>

**ECU Malfunction**

ECU Malfunction

Action Warning

Arming Always

Activation Delay 0s

Parameter	Description
ECU Malfunction Action	<p>The action the DSE module takes when receiving an ECU Malfunction fault condition.</p> <p>The alarm action list is as follows, for more information see the section entitled <i>Alarm Types</i> elsewhere in this document:</p> <p><b>None</b>  <b>Electrical Trip</b>  <b>Shutdown</b>  <b>Warning</b></p>
Arming	<p>Select when the DSE module activates its <i>ECU Malfunction</i> alarm.</p> <p>Options are as follows, for more information see the section entitled <i>Alarm Arming</i> elsewhere in this document:</p> <p><b>Active From Breaker Closed</b>  <b>Active From Mains Parallel</b>  <b>Always</b>  <b>From Safety On</b>  <b>From Starting</b>  <b>Never:</b>  <b>When Stationary</b></p>
Activation Delay	<p>The amount of time before the module activates the <i>ECU Malfunction</i> alarm after receiving an ECU Malfunction fault condition from the ECU.</p>

**ECU Protect**

The screenshot shows a configuration window titled "ECU Protect". It contains three settings:

- Action:** A dropdown menu currently showing "Warning".
- Arming:** A dropdown menu currently showing "From Safety On".
- Activation Delay:** A slider bar set to "0s".

Parameter	Description
ECU Protect Action	<p>The action the DSE module takes when receiving an ECU Protect fault condition.</p> <p>The alarm action list is as follows, for more information see the section entitled <i>Alarm Types</i> elsewhere in this document:</p> <p><b>None</b>  <b>Electrical Trip</b>  <b>Shutdown</b>  <b>Warning</b></p>
Arming	<p>Select when the DSE module activates its <i>ECU Protect</i> alarm.</p> <p>Options are as follows, for more information see the section entitled <i>Alarm Arming</i> elsewhere in this document:</p> <p><b>Active From Breaker Closed</b>  <b>Active From Mains Parallel</b>  <b>Always</b>  <b>From Safety On</b>  <b>From Starting</b>  <b>Never:</b>  <b>When Stationary</b></p>
Activation Delay	<p>The amount of time before the module activates the <i>ECU Protect</i> alarm after receiving an ECU Protect fault condition from the ECU.</p>

### 3.11.9.3 ADVANCED

#### DPTC Filter

DPTC Filter

Enabled

Action Warning

Arming From Safety On

Parameter	Description
DPTC Filter Enabled	<p><input type="checkbox"/> = The DSE module's <i>DPTC Filter</i> alarm is disabled, it does not act upon any DPTC Filter fault conditions from the ECU.</p> <p><input checked="" type="checkbox"/> = The DSE module's <i>DPTC Filter</i> alarm is enabled. The action the DSE module takes when receiving a DPTC Filter fault condition from the ECU. The alarm action list is as follows, for more information see the section entitled <i>Alarm Types</i> elsewhere in this document:</p> <p><b>Electrical Trip</b>  <b>Indication</b>  <b>Shutdown</b>  <b>Warning</b></p>
Arming	<p>Select when the DSE module activates its <i>DPTC Filter</i> alarm. Options are as follows, for more information see the section entitled <i>Alarm Arming</i> elsewhere in this document:</p> <p><b>Always</b>  <b>From Safety On</b>  <b>From Starting</b></p>

#### HEST Active

HEST Active

Enabled

Action Warning

Arming From Safety On

Parameter	Description
HEST Active Enabled	<p><input type="checkbox"/> = The DSE module's <i>HEST</i> alarm is disabled, it does not act upon any HEST fault conditions from the ECU.</p> <p><input checked="" type="checkbox"/> = The DSE module's <i>HEST</i> alarm is enabled. The action the DSE module takes when receiving a HEST fault condition from the ECU. The alarm action list is as follows, for more information see the section entitled <i>Alarm Types</i> elsewhere in this document:</p> <p><b>Indication</b>  <b>Warning</b></p>
Arming	<p>Select when the DSE module activates its <i>HEST</i> alarm. Options are as follows, for more information see the section entitled <i>Alarm Arming</i> elsewhere in this document:</p> <p><b>Always</b>  <b>From Safety On</b>  <b>From Starting</b></p>

**DEF Level**

Parameter	Description
DEF Level Enabled	<p><input type="checkbox"/> = The DSE module's <i>DEF Level</i> alarm is disabled; it does not act upon any DEF Level fault conditions from the ECU.</p> <p><input checked="" type="checkbox"/> = The DSE module's <i>DEF Level</i> alarm is enabled. The action the DSE module takes when receiving a DEF Level fault condition from the ECU. The alarm action list is as follows, for more information see the section entitled <i>Alarm Types</i> elsewhere in this document:</p> <p><b>Electrical Trip</b>  <b>Shutdown</b>  <b>Warning</b></p>
Arming	<p>Select when the DSE module activates its <i>DEF Level</i> alarm. Options are as follows, for more information see the section entitled <i>Alarm Arming</i> elsewhere in this document:</p> <p><b>Always</b>  <b>From Safety On</b>  <b>From Starting</b>  <b>Loading Alarms Activation</b>  <b>Never:</b>  <b>When Stationary</b></p>
Activation Delay	<p>The amount of time before the module activates the <i>DEF Level</i> alarm after a receiving a DEF Level fault condition from the ECU.</p>

**SCR Inducement**

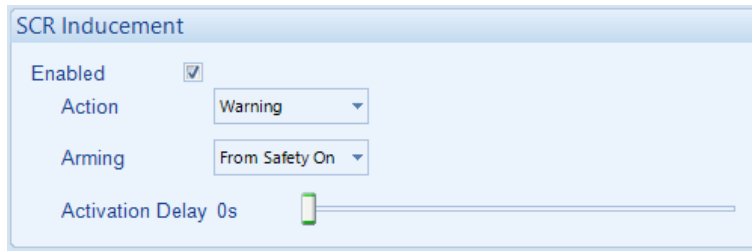

Parameter	Description
SCR Inducement Enabled	<p><input type="checkbox"/> = The DSE module's <i>SCR Inducement</i> alarm is disabled; it does not act upon any SCR Inducement fault conditions from the ECU.</p> <p><input checked="" type="checkbox"/> = The DSE module's <i>SCR Inducement</i> alarm is enabled. The action the DSE module takes when receiving a SCR Inducement fault condition from the ECU.</p> <p>The alarm action list is as follows, for more information see the section entitled <i>Alarm Types</i> elsewhere in this document:</p> <p><b>Electrical Trip</b>  <b>Shutdown</b>  <b>Warning</b></p>
Arming	<p>Select when the DSE module activates its <i>SCR Inducement</i> alarm. Options are as follows, for more information see the section entitled <i>Alarm Arming</i> elsewhere in this document:</p> <p><b>Always</b>  <b>From Safety On</b>  <b>From Starting</b>  <b>Loading Alarms Activation</b>  <b>Never:</b>  <b>When Stationary</b></p>
Activation Delay	<p>The amount of time before the module activates the <i>SCR Inducement</i> alarm after a receiving a SCR Inducement fault condition from the ECU.</p>

### 3.11.10 GAS ENGINE OPTIONS

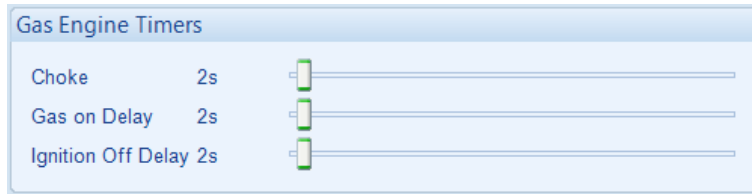

Parameter	Description
Choke Timer	Controls the amount of time that the Gas Choke output is active during the starting sequence.
Gas On Delay	Controls the amount of time between energising the Gas Ignition and energising the Fuel output. Used in the starting sequence to purge old gas from the engine.
Ignition Off Delay	Controls the amount of time between de-energising the Fuel output and de-energising the Gas Ignition output. Used in the stopping sequence to purge unburnt gas from the engine before it is stopped.

### 3.11.11 CRANKING

Cranking settings are used to detect when the set fires during the starting sequence. As the set is cranked, the first parameter that passes its *crank disconnect* setting results in the cessation of the cranking signal.

Having more than one *crank disconnect* source allows for a much faster crank disconnect response leading to less wear on the engine and starter components and provides added safety in case one source is lost, by a blown or tripped fuse for example.

When *Check Oil Pressure Prior to Starting* is enabled, the cranking is not allowed if the oil pressure is not seen as being low. This is used as a *double check* that the engine is stopped before the starter is

#### Options



Parameter	Description
Crank Disconnect on Oil Pressure	<input type="checkbox"/> = The DSE module does not use oil pressure to decide when to disengage the starter motor. <input checked="" type="checkbox"/> = The DSE module does uses oil pressure to decide when to disengage the starter motor in addition to the enabled methods
Check Oil Pressure Prior to Starting	<input type="checkbox"/> = The DSE module does not use oil pressure as an indication if the engine is running. This is disabled for large engines that have an electrical oil pump which is used to maintain oil pressure even when the engine is stationary. <input checked="" type="checkbox"/> = The DSE module uses oil pressure as an indication if the engine is running.

#### Crank Disconnect

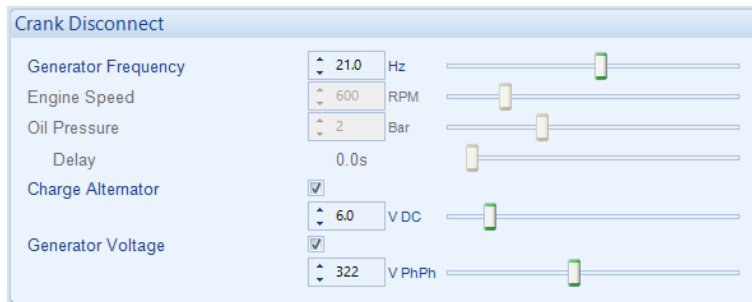

Parameter	Description
Generator Frequency	The DSE module disengages the starter motor when the generator frequency rises above the configured level.
Engine Speed	The DSE module disengages the starter motor when the engine speed rises above the configured level.
Oil Pressure	The DSE module disengages the starter motor when the engine oil pressure rises above the configured level for longer than the configured <i>Delay</i> .
Charge Alternator	<input type="checkbox"/> = The DSE module does not use charge alternator voltage to decide when to disengage the starter motor. <input checked="" type="checkbox"/> = The DSE module disengages the starter motor when the charge alternator voltage rises above the configured level.
Generator Voltage	<input type="checkbox"/> = The DSE module does not use generator voltage to decide when to disengage the starter motor. <input checked="" type="checkbox"/> = The DSE module disengages the starter motor when the generator voltage rises above the configured level.

**Manual Crank**

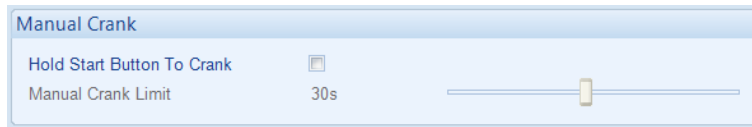

Parameter	Description
Hold Start Button to Crank	<input type="checkbox"/> = When in manual mode, pressing the start button momentarily instructs the generator to go through its cranking procedure. <input checked="" type="checkbox"/> = Releasing the start button during a manual start also disconnects the crank. Manual Crank Limit is provided to protect the engine from being cranked too long in case of a start failure.

### 3.11.12 IDLE SETTING

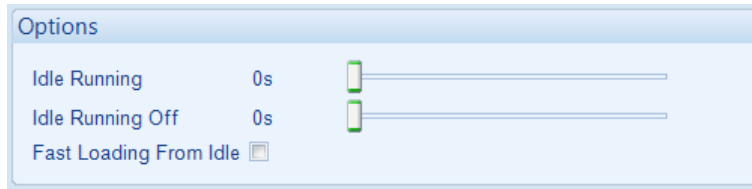

Options	Description
Idle Running	The amount of time that the engine is requested to run at idle speed upon starting. This is typically used to limit emissions at start-up.
Idle Running Off	The amount of time that the engine takes to run up to rated speed after removal of the command to run at idle speed. If this time is too short, the engine is stopped due to an <i>Underspeed</i> alarm. If the time is too long, <i>Underspeed</i> protection is disabled until the <i>Smoke Limit Time Off</i> time has expired.
Fast Loading From Idle	<input type="checkbox"/> = The DSE module waits for the <i>Idle Running Off</i> time to expire, then loads the generator. <input checked="" type="checkbox"/> = During the <i>Idle Running Off</i> time if the <i>Loading Voltage</i> and <i>Loading Frequency</i> are reached, the module terminates the <i>Idle Running Off</i> and loads the generator.

### 3.11.13 SPEED SENSING

Options	
Disable ECM Speed Sensing	<input type="checkbox"/>
Magnetic Pickup Fitted	<input checked="" type="checkbox"/>
Flywheel Teeth	190
Enable Multiple Engage Attempts	<input checked="" type="checkbox"/>
Engage Attempts	2
Loss of Sensing Signal	Shutdown
Disable Under Speed Alarms If Sensor Fails	<input checked="" type="checkbox"/>
Magnetic Pickup Open Circuit	Shutdown

Parameter	Description
Disable ECM Speed Sensing	<input type="checkbox"/> = An ECM is connected to the DSE module and being used for speed sensing. <input checked="" type="checkbox"/> = An ECM is connected to the DSE module, but another form of speed sensing fitted to the DSE module is being used.
Magnetic Pickup Fitted	<div style="border: 1px solid black; padding: 5px;"> <p><b>NOTE: For more detailed information on the Magnetic Pickup Specification, refer to DSE Publication: 057-323 DSEG8600 Operator Manual.</b></p> </div> <input type="checkbox"/> = Magnetic pickup device is not connected to the DSE module. <input checked="" type="checkbox"/> = A low impedance magnetic pickup device is connected to the DSE module to measure engine speed.
Flywheel Teeth	Define the number of pulses which are counted by the speed sensing device in each engine revolution.
Enable Multiple Engage Attempts	<input type="checkbox"/> = No engage attempt is given. If no speed sensing is detected during cranking, the <i>Fail To Start</i> alarm is active. <input checked="" type="checkbox"/> = If no magnetic pickup pulses are detected during cranking, it is assumed that the starter has not engaged to turn the engine. The starter is withdrawn and re-energised for the configured number of <i>Engage Attempts</i> .
Loss of Sensing Signal	If the speed sensing signal is lost during engine running (or not present during cranking when <i>Multiple Engage Attempts</i> is enabled), an alarm is generated: <b>Shutdown</b> <b>Warning</b>
Disable Under Speed Alarms If Sensor Fails	<input type="checkbox"/> = Under speed alarms activate even if speed sensor has failed. <input checked="" type="checkbox"/> = Under speed alarms are disabled when the speed sensor fails.
Magnetic Pickup Open Circuit	If the magnetic pickup device is not detected, an alarm is generated: <b>Shutdown</b> <b>Warning Always Latched</b>

### 3.11.14 SPEED SETTINGS

#### Under Speed

The screenshot shows a configuration window titled 'Under Speed'. It contains several settings:

- Alarm:** A checked checkbox.
- Action:** A dropdown menu set to 'Shutdown'.
- Trip:** A numeric input field set to '1200' with 'RPM' to its right, and a slider below it.
- Pre-Alarm:** A checked checkbox.
- Trip:** A numeric input field set to '1260' with 'RPM' to its right, and a slider below it.
- Return:** A numeric input field set to '1350' with 'RPM' to its right, and a slider below it.
- Activation Delay:** A text input field set to '0s' with a slider below it.

Parameter	Description
Under Speed Alarm	<input type="checkbox"/> = <i>Under Speed</i> alarm is disabled <input checked="" type="checkbox"/> = Under Speed gives an alarm in the event of the engine speed falling below the configured <i>Under Speed Alarm Trip</i> value for longer than the <i>Activation Delay</i> . The <i>Underspeed Alarm Trip</i> value is adjustable to suit user requirements.
Action	Select the type of alarm required from the list: <b>Electrical Trip</b> <b>Shutdown</b>  For details of these, see the section entitled <i>Alarm Types</i> elsewhere in this document.
Pre-Alarm	<input type="checkbox"/> = <i>Under Speed Pre-Alarm</i> is disabled <input checked="" type="checkbox"/> = Under Speed gives a <i>Pre-Alarm</i> in the event of the engine speed falling below the configured <i>Under Speed Pre-Alarm Trip</i> value for longer than the <i>Activation Delay</i> . Once the engine speed rises above the <i>Under Speed Pre-Alarm Return</i> the alarm is reset. The <i>Under Speed Pre-Alarm Trip</i> value is adjustable to suit user requirements.
Activation Delay	This is used to delay the Under Speed Alarm. Useful to prevent short term dips in voltage causing the generator to shut down

**Over Speed**

Parameter	Description
Over Speed Pre-Alarm	<input type="checkbox"/> = Alarm is disabled <input checked="" type="checkbox"/> = Over Speed gives a <i>Pre-Alarm</i> in the event of the engine speed rising above the configured <i>Over Speed Pre-Alarm Trip</i> value for longer than the <i>Activation Delay</i> . The <i>Pre-Alarm</i> is automatically reset when the engine speed falls below the configured <i>Return</i> level. The <i>Over Speed Pre-Alarm Trip</i> value is adjustable to suit user requirements.
Alarm	Over Speed gives a <i>Shutdown</i> alarm in the event of the engine speed rising above the configured <i>Over Speed Alarm Trip</i> value for longer than the <i>Activation Delay</i> . The <i>Over Speed Alarm Trip</i> value is adjustable to suit user requirements.
Activation Delay	This is used to delay the Over Speed Alarm. Useful to prevent short term dips in voltage causing the generator to shut down

**Run Away**

Parameter	Description
Run Away IEEE C37.2 -81 Frequency Relay	<div style="border: 1px solid black; padding: 5px; margin-bottom: 5px;"> <p><b>NOTE: Run Away setting is not available if a magnetic pick-up or an electronic engine is connected.</b></p> </div> <input type="checkbox"/> = Alarm is disabled <input checked="" type="checkbox"/> = In the event of the engine speed rising above the configured <i>Trip</i> value, the <i>Run Away Shutdown</i> alarm is immediately triggered. This is used to protect against engine damage due to uncontrolled speed increase, where the engine speed runs away.
Trip	Set the RPM level for the <i>Run Away</i> alarm.

**Overspeed Options**

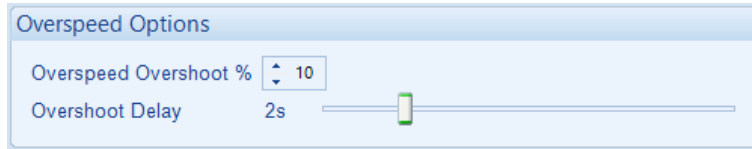

Parameter	Description
Overspeed Overshoot %	To prevent spurious overspeed alarms at engine start up, the module includes configurable <i>Overspeed Overshoot</i> protection. This allows the engine speed to 'overshoot' the Overspeed setting during the starting process for a short time.
Overshoot Delay	Rather than 'inhibiting' the Overspeed alarms, the levels are temporarily raised by the <i>Overspeed Overshoot %</i> for the duration of the <i>Overspeed Overshoot</i> delay from starting.

### 3.11.15 PLANT BATTERY

#### Voltage Alarms

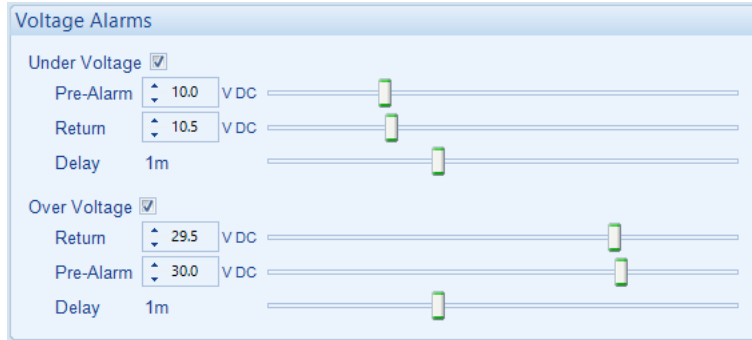

Parameter	Description
Plant Battery Under Voltage IEEE C37.2 -27 DC Undervoltage Relay	<input type="checkbox"/> = The alarm is disabled. <input checked="" type="checkbox"/> = The alarm activates when the battery voltage drops below the configured <i>Pre-Alarm</i> level for the configured <i>Delay</i> time. When the battery voltage rises above the configured <i>Return</i> level, the alarm is deactivated.
Plant Battery Over Voltage IEEE C37.2 -59 DC Overvoltage Relay	<input type="checkbox"/> = The alarm is disabled. <input checked="" type="checkbox"/> = The alarm activates when the battery voltage rises above the configured <i>Pre-Alarm</i> level for the configured <i>Delay</i> time. When the battery voltage drops below the configured <i>Return</i> level, the alarm is deactivated.

#### Charge Alternator Alarms

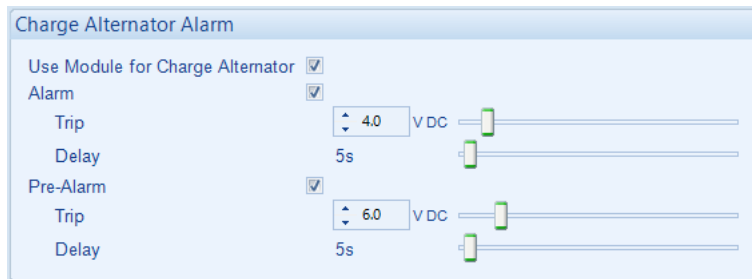

Parameter	Description
Use Module For Charge Alternator	<div style="border: 2px solid black; padding: 5px; margin-bottom: 5px;"> <b>NOTE: The feature is only available when an electronic engine is selected.</b> </div> <input type="checkbox"/> = DSE module measures the charge alternator voltage. <input checked="" type="checkbox"/> = Engine ECU (ECM) provides charge alternator voltage.
Charge Alternator Alarm	<input type="checkbox"/> = The alarm is disabled. <input checked="" type="checkbox"/> = The alarm activates when the charge alternator voltage falls below the configured <i>Trip</i> level for the configured <i>Delay</i> time.
Charge Alternator Pre-Alarm	<input type="checkbox"/> = The alarm is disabled. <input checked="" type="checkbox"/> = The alarm activates when the charge alternator voltage falls below the configured <i>Trip</i> level for the configured <i>Delay</i> time.

### 3.11.16 INLET TEMPERATURE

Provides inlet temperature alarms when the module is used in conjunction with electronic (ECU) engines that support the reading of inlet temperature.

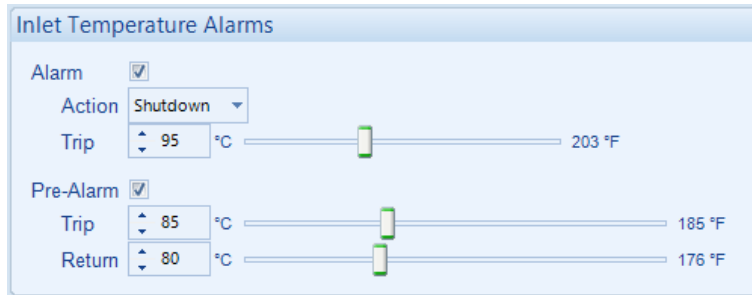

Parameter	Description
Inlet Temperature Alarm	<p><b>NOTE:</b> The feature is only available when an electronic engine is selected.</p> <p><input type="checkbox"/> = Disable the alarm  <input checked="" type="checkbox"/> = <i>Inlet Temperature Alarm</i> is activated when the <i>Inlet Temperature</i> sent from the ECU rise above the <i>Trip</i> level.</p>
Action	<p>Select the type of alarm required from the list:  <b>Electrical Trip</b>  <b>Shutdown</b>                      For details of these, see the section entitled <i>Alarm Types</i> elsewhere in this document.</p>
Inlet Temperature Pre-Alarm	<p><input type="checkbox"/> = The alarm is disabled.  <input checked="" type="checkbox"/> = <i>Inlet Temperature Pre-Alarm</i> is activated when the <i>Inlet Temperature</i> sent from the ECU is above the configured <i>Trip</i> level. The Pre-Alarm is deactivated when the <i>Inlet Temperature</i> falls below the <i>Return</i> level.</p>

### 3.11.17 ENGINE ICON DISPLAYS

**NOTE:** The maximum bitmap size allowed is 119 pixels wide by 41 pixels high.

This section is used with Electronic Engines, it allows to create or define a CAN Lamp icon and how to be displayed when the configured alarm or message is active, such as flashing the CAN icon rapidly or slowly. The first screen is enabled by default, and it cannot be disabled, the second and third screens are configurable to be enabled or disabled through this section to allow the user to create more CAN Icon Displays. The CAN icon instrument is activated based on a DTC message sent from the ECU or according to GenComm instrumentation conditions.

Select the required screen with the mouse to configure, then tick the *Display* box to enable the screen on the module.







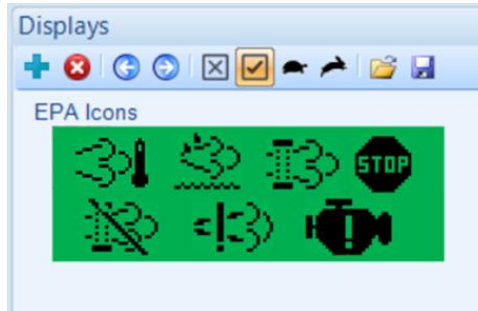

An example showing a customised EPA icon when the screen is enabled.

### 3.11.17.1 ICON INSTRUMENTATION

#### Displays

Select the required Lamp Icon from the screen to configure or click on the  tab to create a new Lamp Icon.



Display tab tools	Description
	Click on the Plus tab to create a new Lamp Icon within the selected screen.
	Click on the delete tab to delete the selected Lamp Icon from the screen.
	Click on the right or left tab to select the next Lamp Icon in the screen.
	Click to hide the instruments from the screens.
	Click to show all the instruments in the screens.
	This tool is for flashing demonstration. Click to flash all the instruments slowly.
	This tool is for flashing demonstration. Click to flash all the instruments rapidly.
	Click to import a saved <i>Engine Icon Displays</i> .
	Click to export the configured <i>Engine Icon Displays</i> .





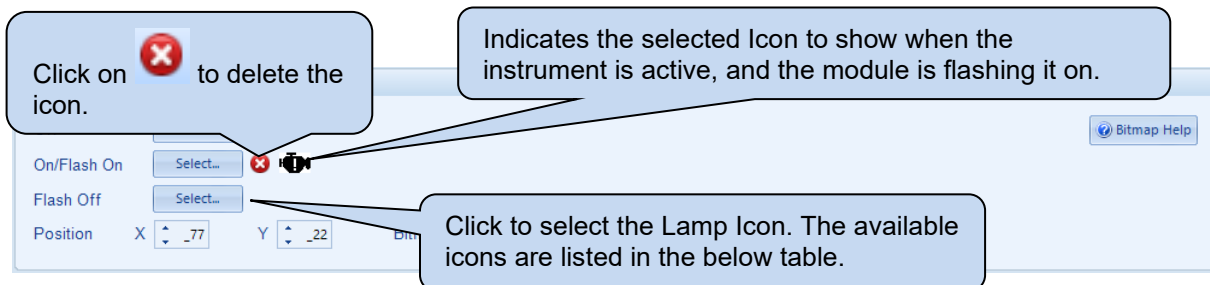





#### Icon Bitmaps

Configure the Icon Bitmaps of the selected instrument from the screen, to show the Lamp Icon when its active or inactive



Icon Bitmaps	Description
Flash On (On)	Select the icon to show when the instrument is active, and the module has flashed on the <i>Engine Icons</i> on the screen.
Flash Off	Select the icon to show when the instrument is active, and the module has flashed off the <i>Engine Icons</i> on the screen.
Off	Select the icon to show when the instrument is not active on the screen.
Position X, Y	Configure the instrument positions for X & Y coordinates on the screen.

Parameter descriptions are continued overleaf...

Lamp Icons	Display
	DEF On Large
	DEF On
	DPF Active
	DPF Inhibit
	DPF Stop
	DPF Warning
	ECU Red Alarm
	ECU Yellow Alarm
	HEST On
	SCR Active Large
	SCR Active

### Icon Instrumentation

Configure the Type of the Instrumentation to read from the DTC or from a GenComm register, and on what condition(s) the selected instrument to be On or flashing.

#### Icon Instrumentation DTC Type

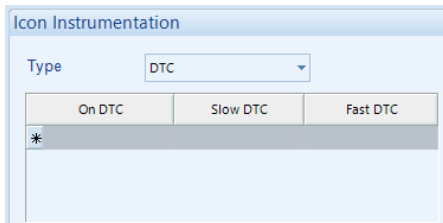

Icon Instrumentation	Description
On DTC	Configure the DTC code to activate the instrument when <i>On DTC</i> satisfied.
Slow DTC	Configure the DTC code to flash the instrument slowly when <i>Slow DTC</i> satisfied.
Fast DTC	Configure the DTC code to flash the instrument rapidly when <i>Fast DTC</i> satisfied.

#### Icon Instrumentation GenComm Type

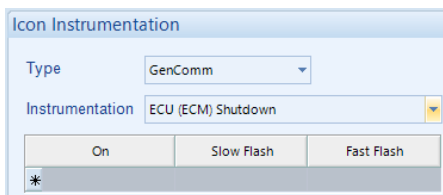

Parameter descriptions are continued overleaf...

Editing the Configuration

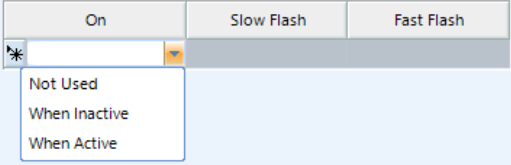
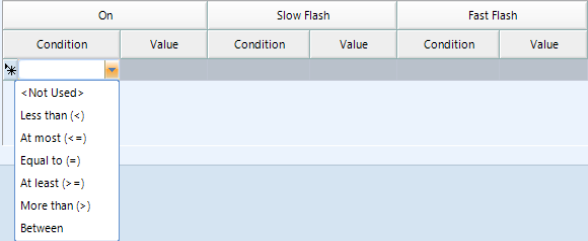
Icon Instrumentation	Description
Instrumentation	Select the instrument to monitor. This may be a flag condition or an instrumentation value.
Flag type of GenComm Icon Instrument	<p>Select the required Condition to activate the Instrumentation Icon, or to Slow Flash, or to Fast Flash based on the options below:</p> <p><i>Not Used</i>  <i>When Inactive</i>  <i>When Active</i></p> 
Instrumentation type of GenComm Icon Instrument	<p>Configure the required Condition to activate the Instrumentation Icon, or to Slow Flash, or to Fast Flash.</p> 

### 3.12 COMMUNICATIONS

The *Communications* page is subdivided into smaller sections. Select the required section with the mouse.

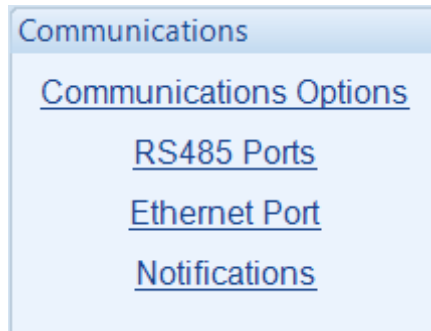

#### 3.12.1 COMMUNICATIONS OPTIONS

Provides a means of giving the controller an identity. This is used in the SCADA section to allow the operator to see the site name and engine identity that it is currently connected to.



Parameter	Description
Site Identity	A free entry box to allow the user to give the DSE module a description of where the site is located. This text is not shown on the module's display and is only seen when performing remote communication. This aids the user in knowing where the generator is located.
Genset Identity	A free entry box to allow the user to give the DSE module a description of which generator it is connected to. This text is not shown on the module's display and is only seen when performing remote communication. This aids the user in knowing which generator on a specific site is being monitored.

### 3.12.2 RS485 PORTS

**NOTE:** When the *RS485 Port Usage* is configured to “*PLC Comms*”, all other modules’ *Port Usage* must be configured to “*GenComm*”. This allows the module configured as “*PLC Comms*” to act as a client and read from the module(s) configured to “*GenComm*.”  
 For details on how to configure the *PLC Editor* to read via its RS485, refer to DSE Publication: *057-314 Advanced PLC Software Manual* which is found on our website: [www.deepseaelectronics.com](http://www.deepseaelectronics.com)

**NOTE:** A maximum of 64 devices are allowed on each port.

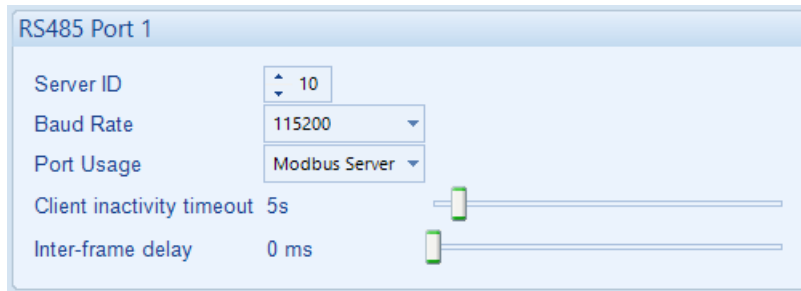

Parameter	Description
Server ID	Select the Server ID of the DSE module’s RS485 port. Every device on the RS485 link must have a unique ID.
Baud Rate	Select the Baud Rate (speed of communication) of the DSE module’s RS485 port. Every device on the RS485 link must have the same Baud Rate. <b>1200</b> <b>2400</b> <b>4800</b> <b>9600</b> <b>14400</b> <b>19200</b> <b>28800</b> <b>38400</b> <b>57600</b> <b>115200</b>
Port Usage	<p><b>NOTE:</b> In a system for a <i>PLC Comms</i> application, only one DSE module must be configured to act as the PLC client. For further details and instructions on using <i>the PLC Comms</i>, refer to DSE Publication: <i>057-314 Advanced PLC Software Manual</i> which is found on our website: <a href="http://www.deepseaelectronics.com">www.deepseaelectronics.com</a></p> <p>Select the RS485 Port 1 or Modbus Engine through application options..  <b>GenComm:</b> Modbus RTU RS485 communication  <b>PLC Comms:</b> The RS485 Port 1 is used to read the other controllers’ registers over the RS485 link which are defined in the <i>PLC Editor</i>.</p>

Parameter descriptions are continued overleaf...

*Editing the Configuration*

Parameter	Description
Client Inactivity Timeout	<p>Set the time delay between a Modbus RTU request and the receipt of a response.</p> <p>The module monitors by default the USB port for communications. When activity is detected on the RS485 port, the module monitors the port for further data. If no data activity is detected on the port for the duration of the <i>Master Inactivity Timer</i>, it reverts to looking at the USB port.</p> <p>This needs to be set longer than the time between Modbus polls from the client.</p>
Inter-frame Delay	<p>Set the time delay between the DSE module receiving a Modbus RTU request and the DSE module's response.</p>

### 3.12.3 ETHERNET

**NOTE:** Consult the network administrator of the host network before changing these settings. Incorrect settings cause network errors in the existing local area network. Qualified network administrators must only change these settings. When the Ethernet settings have been changed the module must be re booted to apply the new settings.

#### IPv4 Link-Local Address Automatically

IPv4 Link-Local Addresses

Obtain IPv4 Link-Local Address Automatically

Parameter	Description
Obtain IPv4 Link-Local Address Automatically	<input type="checkbox"/> = The IPv4 Link-Local Address is disabled, and the unit has to obtain an address from the DHCP server or be configured manually. <input checked="" type="checkbox"/> = The device assigns itself an IP address from the 169.254.0.0 to 169.254.255.255 range using Automatic Private IP Addressing (APIPA).

#### Dynamic Host Configuration Protocol

Dynamic Host Configuration Protocol

Obtain IP Address Automatically

Parameter	Description
Obtain IP Address Automatically	<input type="checkbox"/> = The Dynamic Host Configuration Protocol (DHCP) is disabled, and the unit has a fixed IP address as configured in the <i>IP Address</i> section. <input checked="" type="checkbox"/> = The Dynamic Host Configuration Protocol (DHCP) is enabled, and the unit automatically attains an IP address from the network it is connected to if it has DHCP enabled.

#### Names

Names

Domain Name: DSE Module

Host Name: Company

Vendor Name: Deep Sea Electronics

Parameter	Description
Domain Name	The hostname of the device which is used for DHCP requests and acknowledgements. Consult the network IT manager for suitable naming
Host Name	Additional description string for DHCP
Vendor Name	Additional description string for DHCP

**IP Address**

IP Addresses				
IP address	192	168	1	100
Subnet Mask	255	255	255	0
Gateway Address	0	0	0	0
DNS Address	0	0	0	0
Preferred Connection Address	0	0	0	0

Parameter	Description
IP Address	The static IP address of the module.
Subnet Mask	The subnet mask is to determine whether the module is on the local subnet or on a remote network.
Gateway Address	IP address of the internet router that module is connected to.
DNS Address	IP address of the Domain Name Service (DNS). Usually this is the same as the module's IP address.
Preferred Connection Address	The module allows up to five Modbus clients to connect to it. The <i>Preferred Connection Address</i> enables the unit to reserve one of the five connections for a specific IP address, such as for a remote display module to ensure it always connects.

**Modbus**

Modbus	
Modbus Port Number	502

Parameter	Description
Modbus Port Number	The port number which the module serves Modbus traffic on.

### 3.12.3.1 FIREWALL CONFIGURATION FOR INTERNET ACCESS

As modem/routers differ enormously in their configuration, it is not possible for DSE to give a complete guide to their use with the DSE module. However, it is possible to give a description of the requirements in generic terms. For information on how to establish a connection to a modem/router, please consult the supplier of the modem/router equipment.

The DSE module makes its data available to a configurable TCP port number. The modem/router must be configured to allow inbound traffic on this port. Refer to the WAN interface device (modem/router) manufacturer for more information.

### 3.12.3.2 INCOMING TRAFFIC (VIRTUAL SERVER)

Network Address and Port Translation (NAPT) allows a single device, such as the modem/router gateway, to act as an agent between the Internet (or "public external network") and a local (or "internal private") network. This means that only a single, unique IP address is required to represent an entire group of computers.

For our DSE module application, this means that the WAN IP address of the modem/router is the IP address we need to access the site from an external (internet) location.

When requests reach the modem/router, we want this passed to a 'virtual server' for handling, in our case this is the DSE module.

#### Example:

Virtual Servers		
Filter Name	Source Port	Destination (LAN) Address
DSEG8600	1003	192.168.1.45

The diagram shows a table with three columns: Filter Name, Source Port, and Destination (LAN) Address. The first row contains the values DSEG8600, 1003, and 192.168.1.45. Three callout boxes provide explanations: one for the Filter Name (DSEG8600) stating 'User provided name for the Port Forwarding rule.', one for the Source Port (1003) stating 'Port number of the communications (must match the configuration of the DSE controller).', and one for the Destination (LAN) Address (192.168.1.45) stating 'IP Address of the DSE controller connected to the LAN.'

**Result:** Traffic arriving from the WAN (internet) on Port 1003 is automatically sent to IP address 192.168.1.45 on the LAN (DSE module) for handling.

### 3.12.4 NOTIFICATIONS

The *Notifications* page is subdivided into smaller sections. Select the required section with the mouse.

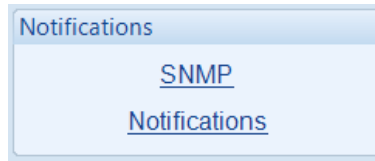

#### 3.12.4.1 SNMP

**NOTE:** The SNMP V2c MIB file for the module is available to download from the DSE website: [www.deepseaelectronics.com](http://www.deepseaelectronics.com).

The module supports SNMP v2c with GetRequest, SetRequest, GetNextRequest, GetBulkRequest and Response. The module also allows communication up to two different SNMP managers at the same time on different IP addresses.

A fixed MIB file is available for the module for use by external SNMP managers. The MIB file is a file used by the SNMP manager to give context to the information held within the module.

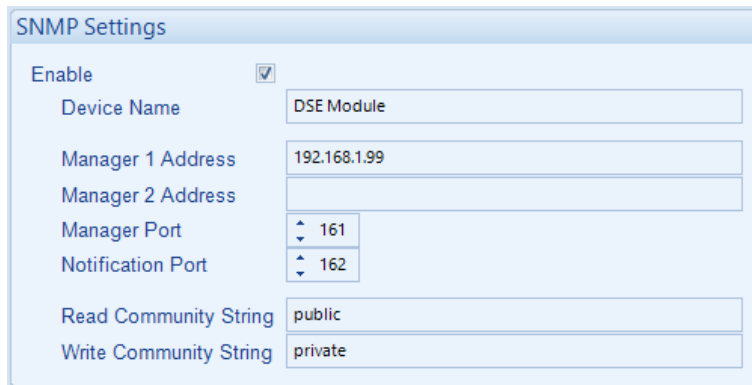

Parameter	Description
Enable	<input type="checkbox"/> = The SNMP function is disabled <input checked="" type="checkbox"/> = The SNMP function is enabled. The module communicates with the SNMP manager using its ethernet port.
Device Name	The name of the module which is attainable by SNMP requests using sysName OID contained within the standard RFC1213 MIB file.
Manager 1 Address	The static IP address of the first SNMP manager.
Manager 2 Address	The static IP address of the second SNMP manager.
Manager Port	The port number which the module serves SNMP GET, GET Next, Get Bulk, Get Subtree, Walk and SET messages.
Notification Port	The port number which the module sends SNMP TRAP messages via.
Read Community String	The SNMP <i>Read Community String</i> . (Factory setting <i>public</i> )
Write Community String	The SNMP <i>Write Community String</i> . (Factory setting <i>private</i> )

Parameter descriptions are continued overleaf...

### 3.12.4.2 NOTIFICATIONS

This page allows the user to select the types of events which are sent to the SNMP managers as SNMP TRAP messages.

Event Type	SNMP Trap
Named Alarms	<input type="checkbox"/>
Unnamed Alarms	<input type="checkbox"/>
Mode Change	<input type="checkbox"/>
Power Up	<input type="checkbox"/>
Engine Starts	<input type="checkbox"/>
Engine Stops	<input type="checkbox"/>
Mains Fail	<input type="checkbox"/>
Mains Return	<input type="checkbox"/>
ECU Lamps	<input type="checkbox"/>
Fuel Level Monitoring	<input type="checkbox"/>
Incorrect Password Entered	<input type="checkbox"/>
Application Switched Multi Set	<input type="checkbox"/>
Application Switched Single Set	<input type="checkbox"/>
Generator Breaker Opened	<input type="checkbox"/>
Generator Breaker Closed	<input type="checkbox"/>

Parameter	Description
Named Alarms	<input type="checkbox"/> = No SNMP TRAPs are sent when a <i>Named Alarm</i> activates. <input checked="" type="checkbox"/> = An SNMP TRAP is sent when a <i>Named Alarm</i> activates. A <i>Named Alarm</i> is a protection with a pre-set name, e.g., Generator Over Voltage.
Unnamed Alarms	<input type="checkbox"/> = No SNMP TRAPs are sent when an <i>Unnamed Alarm</i> activates. <input checked="" type="checkbox"/> = An SNMP TRAP is sent when an <i>Unnamed Alarm</i> activates. An <i>Unnamed Alarm</i> is a protection with a user configured name, e.g., a digital input configured for <i>User Configured</i> .
Mode Change	<input type="checkbox"/> = No SNMP TRAPs are sent when the module changes operating mode. <input checked="" type="checkbox"/> = An SNMP TRAP is sent to indicate the operating mode has changed and what it has changed to.
Power Up	<input type="checkbox"/> = No SNMP TRAPs are sent when the module powers up. <input checked="" type="checkbox"/> = An SNMP TRAP is sent when the module powers up.
Engine Starts	<input type="checkbox"/> = No SNMP TRAPs are sent when the engine starts. <input checked="" type="checkbox"/> = An SNMP TRAP is sent when the engine starts.
Engine Stops	<input type="checkbox"/> = No SNMP TRAPs are sent when the engine stops. <input checked="" type="checkbox"/> = An SNMP TRAP is sent when the engine stops.
Mains Fail	<input type="checkbox"/> = No SNMP TRAPs are sent when the mains fails. <input checked="" type="checkbox"/> = An SNMP TRAP is sent when the mains fails.
Mains Return	<input type="checkbox"/> = No SNMP TRAPs are sent when the mains returns. <input checked="" type="checkbox"/> = An SNMP TRAP is sent when the mains returns.
ECU Lamps	<input type="checkbox"/> = No SNMP TRAPs are sent when the ECU Lamps are active. <input checked="" type="checkbox"/> = An SNMP TRAP is sent when the ECU Lamps are active
Fuel Level Monitoring	<input type="checkbox"/> = No SNMP TRAPs are sent when a <i>Fuel Level Monitoring</i> event is logged within the module's event log. <input checked="" type="checkbox"/> = An SNMP TRAP is sent when a <i>Fuel Level Monitoring</i> event is logged within the module's event log.

Parameter descriptions are continued overleaf...

Editing the Configuration

Parameter	Description
Incorrect Password Entered	<input type="checkbox"/> = No SNMP TRAPs are sent when an <i>Incorrect Password</i> is entered. <input checked="" type="checkbox"/> = An SNMP TRAP is sent when an <i>Incorrect Password</i> is entered.
Application Switched (Multi Set)	<input type="checkbox"/> = No SNMP TRAPs are sent when the Application Switched is Multi Set. <input checked="" type="checkbox"/> = An SNMP TRAP is sent when the Application Switched is Multi Set
Application Switched (Single Set)	<input type="checkbox"/> = No SNMP TRAPs are sent when the Application Switched is Single Set. <input checked="" type="checkbox"/> = An SNMP TRAP is sent when the Application Switched is Single Set
Generator Breaker Opened	<input type="checkbox"/> = No SNMP TRAPs are sent when the Generator Breaker is Opened. <input checked="" type="checkbox"/> = An SNMP TRAP is sent when the Generator Breaker is Opened
Generator Breaker Closed	<input type="checkbox"/> = No SNMP TRAPs are sent when the Generator Breaker is Closed. <input checked="" type="checkbox"/> = An SNMP TRAP is sent when the Application Switched is Closed

### 3.13 SCHEDULER

The section is subdivided into smaller sections.

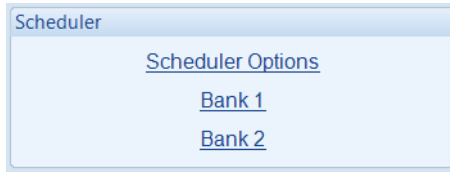

#### 3.13.1 SCHEDULER OPTIONS

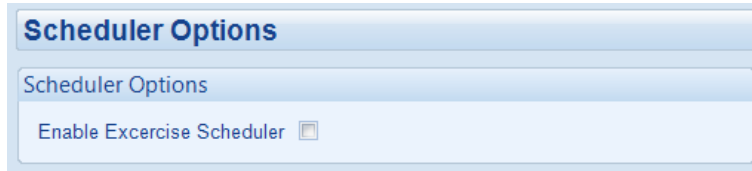

Function	Description
Enable Exercise Scheduler	<input type="checkbox"/> = The scheduler is disabled. <input checked="" type="checkbox"/> = The scheduler is enabled, Bank 1 and Bank 2 become editable.

### 3.13.2 BANK 1 / BANK 2

**NOTE:** If the module application is in **Single Set Mode** and is switched to **Multi Set mode** then the **Run Mode** defaults to **On Load (Multi Set)**.  
**If the module application is switched from Multi Set Mode to Single Set Mode then the Run Mode defaults to Parallel Mode (Single Set).**

Each Bank of the Exercise Scheduler is used to give up to 8 scheduled runs per bank, 16 in total. This run schedule is configurable to repeat every 7 days (weekly) or every 28 days (monthly). The run is *On Load*, *Off Load* or *Auto Start Inhibit*.

Each scheduler bank configured differently either to weekly or monthly based exercises.

Week	Day	Run Mode	Start Time	Duration	
First	Monday	Off Load	00:00	00:00	Clear
First	Monday	Off Load	00:00	00:00	Clear
First	Monday	Off Load	00:00	00:00	Clear
First	Monday	Off Load	00:00	00:00	Clear
First	Monday	Off Load	00:00	00:00	Clear
First	Monday	Off Load	00:00	00:00	Clear
First	Monday	Off Load	00:00	00:00	Clear
First	Monday	Off Load	00:00	00:00	Clear

Function	Description
Schedule Period	Determines the repeat interval for the scheduled run. Options available are: <b>Weekly:</b> The schedule events occur every week. <b>Monthly:</b> The schedule events occur every month on the week selected.
Week	Specifies the week of the month, on which the scheduled run takes place
Day	Specifies the day of week, on which the scheduled run takes place
Run Mode	Determines the loading state mode of the generator when running on schedule  <b>Auto Start Inhibit:</b> The generator is prevented from running in <i>Auto Mode</i> . <b>Island (Single Set):</b> The module runs the generator in island mode, generator breaker closed, and mains breaker opened. <b>Off Load:</b> The module runs the generator on schedule with the load switch open <b>On Load (Multi Set):</b> The module runs the generator on schedule and closes the load switch <b>Parallel (Single Set):</b> In <i>Generator Mode</i> , the module starts the generator and closes the generator breaker to provide the configured amount of power. In <i>Mains Mode</i> , the module starts the generator and closes the generator breaker for peak lopping.
Start Time	Determines at what time of day the scheduled run starts
Duration	Determines the time duration in hours for the scheduled run
Clear	Resets the values for the Day, Start Time, and Duration to defaults

### 3.14 MAINTENANCE ALARM

**NOTE:** There are three ways to reset the maintenance alarm:  
 1) Activate a digital input configured to *Maintenance Reset Alarm*.  
 2) Use the SCADA | Maintenance | Maintenance Alarm section of this PC Software.  
 3) Through the *Front Panel Editor* of the module

#### Maintenance Alarms 1 to 3

Function	Description
Enable	<input type="checkbox"/> = The maintenance alarm is disabled. <input checked="" type="checkbox"/> = The maintenance alarm is activated with the configured <i>Action</i> when the engine hours increase more than the <i>Engine Run Hours</i> or when the date increase more than the <i>Maintenance Interval</i> settings.
Description	The text that is displayed on the module's LCD when the maintenance alarm activates.
Action	<div style="border: 3px double black; padding: 5px; margin-bottom: 5px;"> <p><b>NOTE:</b> For details of these, see the section entitled <i>Alarm Types</i> elsewhere in this document.</p> </div> Select the type of alarm required from the list: <b>Shutdown</b> <b>Warning</b>
Engine Run Hours	The value the engine hours must increase by to trigger the maintenance alarm.
Enable Alarm on Due Date	<input type="checkbox"/> = The maintenance alarm only activates on the engine hours increasing <input checked="" type="checkbox"/> = The maintenance alarm activates on the engine hours increasing or the date increasing, whichever occurs first.
Maintenance Interval	The value the date must increase by to trigger the maintenance alarm.

### 3.15 CONFIGURABLE CAN INSTRUMENTATION

**NOTE:** For further details and instructions on using *Configurable CAN*, refer to DSE Publication: *056-118 PLC Configurable CAN* which is found on our website: [www.deepseaelectronics.com](http://www.deepseaelectronics.com)



The *Configurable CAN Instrumentation* section is subdivided into smaller sections. Select the required section with the mouse.



### 3.15.1 RECEIVED INSTRUMENTATION (1-30)

This feature allows for up to thirty custom engine CAN instrumentation items to be decoded from CAN messages on the connected ECU port.

Instrumentation Configuration				
	Enabled	On Module	Description	
1	<input checked="" type="checkbox"/>	<input checked="" type="checkbox"/>	Configurable CAN 1	Details...
2	<input checked="" type="checkbox"/>	<input checked="" type="checkbox"/>	Configurable CAN 2	Details...
3	<input checked="" type="checkbox"/>	<input checked="" type="checkbox"/>	Configurable CAN 3	Details...
4	<input checked="" type="checkbox"/>	<input checked="" type="checkbox"/>	Configurable CAN 4	Details...
5	<input checked="" type="checkbox"/>	<input checked="" type="checkbox"/>	Configurable CAN 5	Details...
6	<input checked="" type="checkbox"/>	<input checked="" type="checkbox"/>	Configurable CAN 6	Details...
7	<input checked="" type="checkbox"/>	<input checked="" type="checkbox"/>	Configurable CAN 7	Details...
8	<input checked="" type="checkbox"/>	<input checked="" type="checkbox"/>	Configurable CAN 8	Details...
9	<input checked="" type="checkbox"/>	<input checked="" type="checkbox"/>	Configurable CAN 9	Details...
10	<input checked="" type="checkbox"/>	<input checked="" type="checkbox"/>	Configurable CAN 10	Details...

Parameter	Description
Enabled	<p> <b>NOTE: The CAN instrumentation must already be available on the CAN bus. There is no request for a non-standard instrumentation.</b></p> <p><input type="checkbox"/> = The CAN instrumentation is disabled.  <input checked="" type="checkbox"/> = The CAN instrumentation is enabled. Reading depends upon the message availability on the bus.</p>
On Module	<p> <b>NOTE: The CAN instrumentation is always available on the SCADA, Data Logging, PLC if at least one CAN instrumentation is enabled. The CAN instrumentation is shown on the DSE module's display when the On Module is enabled.</b></p> <p><input type="checkbox"/> = The CAN instrumentation is not displayed on the DSE module.  <input checked="" type="checkbox"/> = The CAN instrumentation is displayed on the DSE module.</p>
Description	Provide a description for the CAN instrumentation. This description is only shown in the SCADA.
Details	Click on Details to set the <i>Message Decoding CAN</i> options.

### 3.15.1.1 DETAILS

#### Message Identification

Parameter	Description
Message Type	Select the required message type: <b>11 Bit:</b> message identifier for standard CAN <b>29 Bit:</b> message identifier for extended CAN
Message ID	CAN message ID
Enabled	<input type="checkbox"/> = Timeout is disabled <input checked="" type="checkbox"/> = Timeout is enabled
Timeout	It indicates how often the messages are expected to be seen on the CAN bus. If no new instrumentation is seen beyond the timeout period, the calculated instrumentation value changes to a 'bad data' sentinel value.

#### Data Structure

Parameter	Description
Offset Byte	Set the start position Byte
Offset Bit	Set the start position Bit
Length (Bits)	Data length 1-32 bits
Signed Value	<input type="checkbox"/> = Unsigned value <input checked="" type="checkbox"/> = Signed value

**Display**

**▲ NOTE: If the received CAN instrument is outside the configured raw values, the module displays sentinel value.**

**Display**

Decimal Places

Suffix

Smallest Raw Value  Maps To

Largest Raw Value  Maps To

Parameter	Description
Decimal Places	Display the decimal point. 0 represents 0 scaling factor, 1 represents 0.1 scaling factor, -1 represents 10 multiplier.
Suffix	Unit display (example: m <sup>3</sup> /hr)
Smallest Raw Value	The smallest data sent over the CAN bus before the transformations (decimal places).
Maps To	The output format after all transformations including decimal point shift) as to be shown on the module screen, or SCADA, in data log file, etc.
Largest Raw Value	The largest data sent over the CAN bus before the transformations (decimal places).
Maps To	The output format after all transformations including decimal point shift) as to be shown on the module screen, or SCADA, in data log file, etc.

**Test**

**Test**

Raw Value

Displayed Value 0

Parameter	Description
Test Raw Value	<div style="border: 1px solid black; padding: 5px; margin-bottom: 5px;"> <p><b>▲ NOTE: The Test Raw Value is not saved in the configuration, this is only to check the displayed value.</b></p> </div> <p>This is a test case to check the representation of the <i>Raw Value</i> when they are complicated. <i>Test Raw Value</i> is the value read from the CAN bus before the transformation</p>
Displayed Value	The <i>Test Raw Value</i> 's represented value as to be shown on the DSE module's screen, or in the Scada.

### 3.15.2 TRANSMITTED INSTRUMENTATION

The module allows transmitting up to ten instruments over the CANbus on the ECU port by specifying the source address (message ID) of the selected Instrument.



Parameter	Description
Enabled	<input type="checkbox"/> = The Transmit CAN instrumentation is disabled. <input checked="" type="checkbox"/> = The Transmit CAN instrumentation is enabled.
Source	Select the instrument to be created over the CAN.
Details	Click on Details to set the <i>Message Encoding</i> CAN options.

#### 3.15.2.1 DETAILS

##### Message Identification

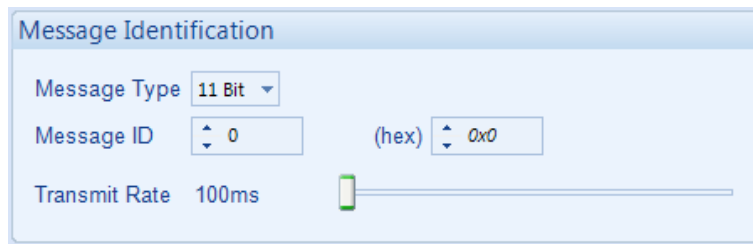

Parameter	Description
Message Type	Select the required message type to transmit: <b>11 Bit:</b> message identifier for standard CAN <b>29 Bit:</b> message identifier for extended CAN
Message ID	CAN message ID
Transmit Rate	The rate at which the <i>CAN Instrument</i> is transmitted over the CANbus.

**Data Structure**

**Data Structure**

Offset      Byte       Bit

Length (Bits)

Signed Value

Parameter	Description
Offset Byte	Set the start position Byte
Offset Bit	Set the start position Bit
Length (Bits)	Data length 1-32 bits
Signed Value	<input type="checkbox"/> = Transmit unsigned value <input checked="" type="checkbox"/> = Transmit signed value

**Mapping**

**Mapping**

Smallest Source Value       Maps To

Largest Source Value       Maps To

Parameter	Description
Smallest Source Value	The smallest instrument value before being sent over the CAN bus.
Maps To	The transmitted format for the <i>Smallest Source Value</i> .
Largest Source Value	The largest instrument value before being sent over the CAN bus.
Maps To	The transmitted format for the <i>Largest Source Value</i> .

**Test**

**Test**

Source Value

Mapped Value 0

Parameter	Description
Source Value	<div style="border: 2px solid black; padding: 5px;"> <p><b>▲ NOTE: The Source Value is not transmitted over the CANbus, this is only to check the encoded value.</b></p> </div> <p>This is a test case to check the representation of the <i>Source Value</i> when they are complicated. <i>Source Value</i> is the instrument value before being encoded.</p>
Mapped Value	The <i>Mapped Value</i> represents the transmitted <i>Source value</i> .

### 3.15.3 EXPORT / IMPORT CONFIGURABLE CAN

This feature is used to import the *Configurable CAN Instrumentation* settings into another DSE module.

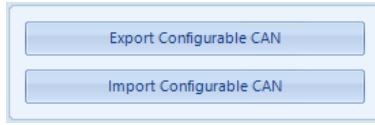

Parameter	Description
Export	This allows the configuration settings of all Configurable CAN Instrumentation (Received & Transmitted) into one XML file.
Import	This allows to import an existing configuration setting of all Configurable CAN Instrumentation saved in XML format.

### 3.16 ALTERNATIVE CONFIGURATIONS

An Alternative Configurations are provided to allow the system designer to cater for different AC requirements utilising the same generator system. Typically, Rental Set Manufacturers use this feature where the set is capable of being operated at (for instance) 120 V 50 Hz and 240V 50 Hz using a selector switch.

The Alternative Configuration is selected using either:

- Configuration Suite Software (Selection for 'Default Configuration')
- Module Front Panel Editor
- Via external signal to the module input configured to "Alternative Configuration" select.
- Auto Voltage Sensing (Multi Set) selects the relevant alternative during generator starting (if configured)

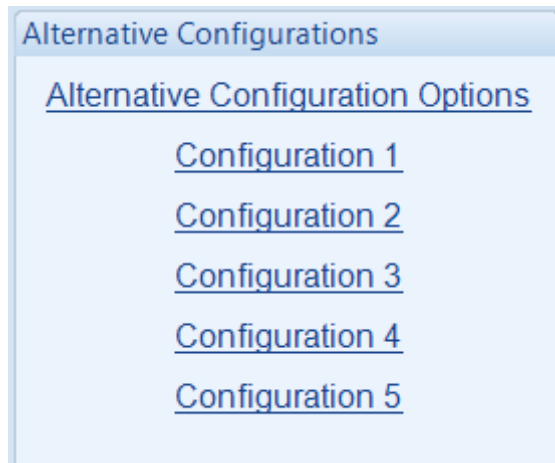

#### 3.16.1 ALTERNATIVE CONFIGURATION OPTIONS

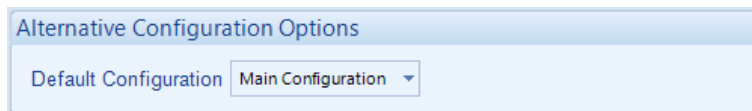

Parameter	Description
Default Configuration	Select the 'default' configuration that is used when there is no instruction to use an 'alternative configuration.'

### 3.16.2 ALTERNATIVE CONFIGURATION 1 TO 5

The Alternative Configurations Editor allows for editing of the parameters that are to be changed when an Alternative Configuration is selected.

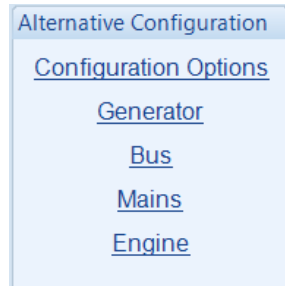

#### 3.16.2.1 CONFIGURATION OPTIONS

##### Enable Alternative Configuration

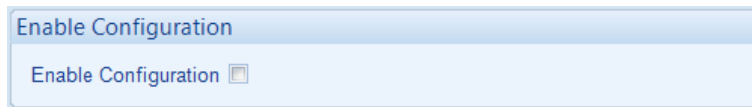

Parameter	Description
Enable Configuration	<input type="checkbox"/> = <i>Alternative Configuration</i> is disabled. <input checked="" type="checkbox"/> = <i>Alternative Configuration</i> is enabled. The configuration is enabled by changing the <i>Default Configuration</i> , activating a digital input or through the module's <i>Front Panel Editor</i> .

#### 3.16.2.2 GENERATOR / ENGINE /BUS / MAINS / ENGINE

Alternative configuration options contain a subset of the main configuration. The adjustable parameters are not discussed here as they are identical to the main configuration options:

- [-] Alternative Configurations
  - Alternative Configuration Options
  - [-] Configuration 1
    - Configuration Options
    - [-] Generator
      - Generator Options
      - Generator Voltage
      - Generator Frequency
      - [+] Generator Current
      - [+] Generator Power
      - Generator Rating
      - [-] Synchronising
        - Load Control
        - AVR
    - [+] Engine
    - [+] Configuration 2
    - [+] Configuration 3
    - [+] Expansion

Configuration menus for the *Alternative Configuration*. For information about the configuration items within this section, refer to their description in the 'main' configuration.

- [-] Engine
  - Engine Protection
  - Oil Pressure
  - [+] Coolant Temperature
  - [+] Fuel Level
  - Fuel Use and Efficiency
  - DEF Level
  - Engine Options
  - ECU (ECM) Options
  - [+] ECU (ECM) Alarms
  - Gas Engine Options
  - Cranking
  - Idle Setting
  - Speed Sensing
  - Speed Settings
  - Plant Battery
  - Inlet Temperature
  - Engine Icon Displays
- [-] Bus
  - Bus Options
  - Bus Sequence Alarms
- [-] Mains
  - Mains Options
  - Mains Voltage Alarms
  - Mains Sequence Alarms
  - Mains Frequency Alarms
  - Mains Current

### 3.17 EXPANSION

**NOTE:** A comms failure to the expansion module may cause the controller to stop reacting to it. If a digital input is critical then the alarm on the expansion module must be set to *Electrical Trip or Shutdown*. If the link is lost to an expansion unit then it behaves as if it is powered down.

The *Expansion* page is subdivided into smaller sections.  
Select the required section with the mouse.



See overleaf for description of the different expansion modules.

### 3.17.1 DSE2130 INPUT MODULES

Select the DSENet ID of the input expansion to be configured. The ID of the expansion module is set by rotary decimal switch accessible under the removable cover of the device.

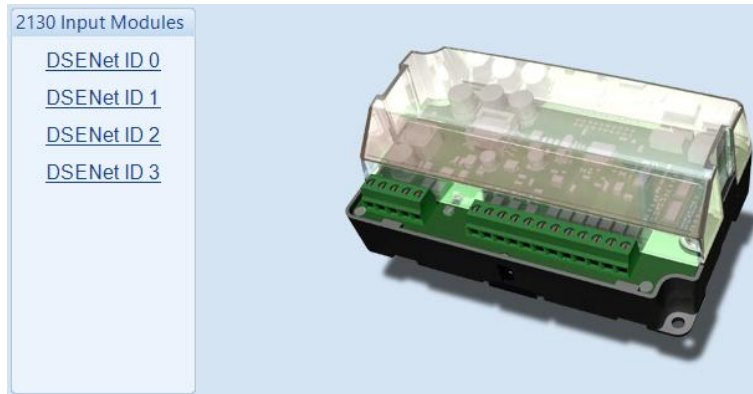

The following options are then shown:

#### 2130 Expansion Enable

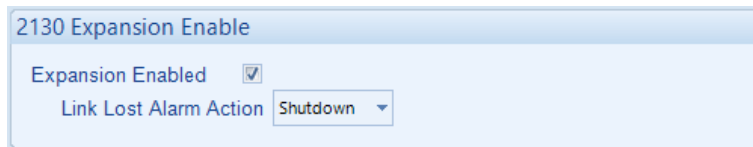

Parameter	Description
Expansion Enabled	<input type="checkbox"/> = The expansion module with the selected ID is not enabled. <input checked="" type="checkbox"/> = The expansion module with the selected ID is enabled. If the expansion module is not connected / detected by the module, the module generates an <i>Exp. Unit Failure</i> alarm with the configured <i>Link Lost Alarm Action</i> severity.

#### 2130 Expansion Inputs

The *Expansion Unit* page is then subdivided into smaller sections. Select the required section with the mouse.

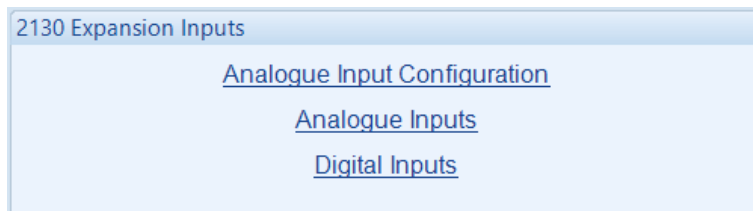

### 3.17.1.1 ANALOGUE INPUT CONFIGURATION

#### Input Configuration

Parameter	Description
Analogue Input E to H	Select what the analogue input is to be used for: <b>Not Used:</b> The analogue input is disabled <b>Digital Input:</b> Configured on the 2130/Digital Inputs pages <b>Flexible Analogue:</b> Configured on the 2130/Analogue Inputs pages

### 3.17.1.2 ANALOGUE INPUTS

 **NOTE:** An analogue input is only configurable as a flexible sensor if it has been configured as Flexible Analogue, for further details refer to the section entitled *Analogue Input Configuration* elsewhere in this document.

#### Sensor Description

Parameter	Description
Sensor Name	Enter the <i>Sensor Name</i> , this text is shown on the module display when viewing the instrument.

#### Input Type

Parameter	Description
Input Type	Select the sensor type and curve from a pre-defined list or create a user-defined curve.  Available sensor types: <b>Resistive:</b> for sensors with maximum range of 0 $\Omega$ to 3 k $\Omega$  Available parameters to be measured: <b>Pressure:</b> The input is configured as a pressure sensor <b>Percentage:</b> The input is configured as a percentage sensor <b>Temperature:</b> The input is configured as a temperature sensor

**Sensor Alarms**

Parameter	Description
Alarm Arming	<p><b>NOTE:</b> For details of these, see the section entitled <i>Alarm Arming</i> elsewhere in this document.</p> <p>Select when the alarm generated by the analogue input becomes active:  <b>Always</b>  <b>From Safety On</b>  <b>From Starting</b></p>
Low Alarm Enable	<p><input type="checkbox"/> = The Alarm is disabled.  <input checked="" type="checkbox"/> = The <i>Low Alarm</i> activates when the measured quantity drops below the <i>Low Alarm</i> setting.</p>
Low Alarm Action	<p><b>NOTE:</b> For details of these, see the section entitled <i>Alarm Types</i> elsewhere in this document.</p> <p>Select the type of alarm required from the list:  <b>Electrical Trip</b>  <b>Shutdown</b></p>
Low Pre-Alarm Enable	<p><input type="checkbox"/> = The Pre-Alarm is disabled.  <input checked="" type="checkbox"/> = The <i>Low Pre-Alarm</i> is active when the measured quantity drops below the <i>Low Pre-Alarm Trip</i> setting. The <i>Low Pre-Alarm</i> is automatically reset when the measured quantity rises above the configured <i>Low Pre-Alarm Return</i> level.</p>
Low Alarm String	<p>The text that is displayed on the module's LCD when the <i>Low Alarm</i> or <i>Low Pre-Alarm</i> activates.</p>

Parameter descriptions are continued overleaf...

Editing the Configuration

Parameter	Description
High Pre-Alarm Enable	<input type="checkbox"/> = The Pre-Alarm is disabled. <input checked="" type="checkbox"/> = The <i>High Pre-Alarm</i> is active when the measured quantity rises above the <i>High Pre-Alarm Trip</i> setting. The <i>High Pre-Alarm</i> is automatically reset when the measured quantity falls below the configured <i>High Pre-Alarm Return</i> level.
High Alarm Enable	<input type="checkbox"/> = The Alarm is disabled. <input checked="" type="checkbox"/> = The <i>High Alarm</i> is active when the measured quantity rises above the <i>High Alarm</i> setting.
High Alarm Action	<div style="border: 1px solid black; padding: 5px; margin-bottom: 5px;">  <b>NOTE: For details of these, see the section entitled <i>Alarm Types</i> elsewhere in this document.</b> </div> <p>Select the type of alarm required from the list:  <b><i>Electrical Trip</i></b>  <b><i>Shutdown</i></b></p>
High Alarm String	The text that is displayed on the module's LCD when the <i>High Alarm</i> or <i>High Pre-Alarm</i> activates.

### **3.17.1.3 DIGITAL INPUTS**

The *Digital Inputs* section is subdivided into smaller sections. Select the required section with the mouse.

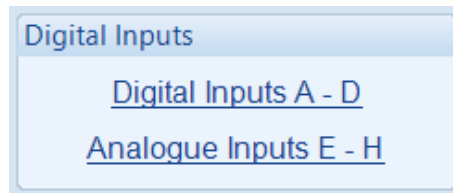

3.17.1.3.1 DIGITAL INPUTS

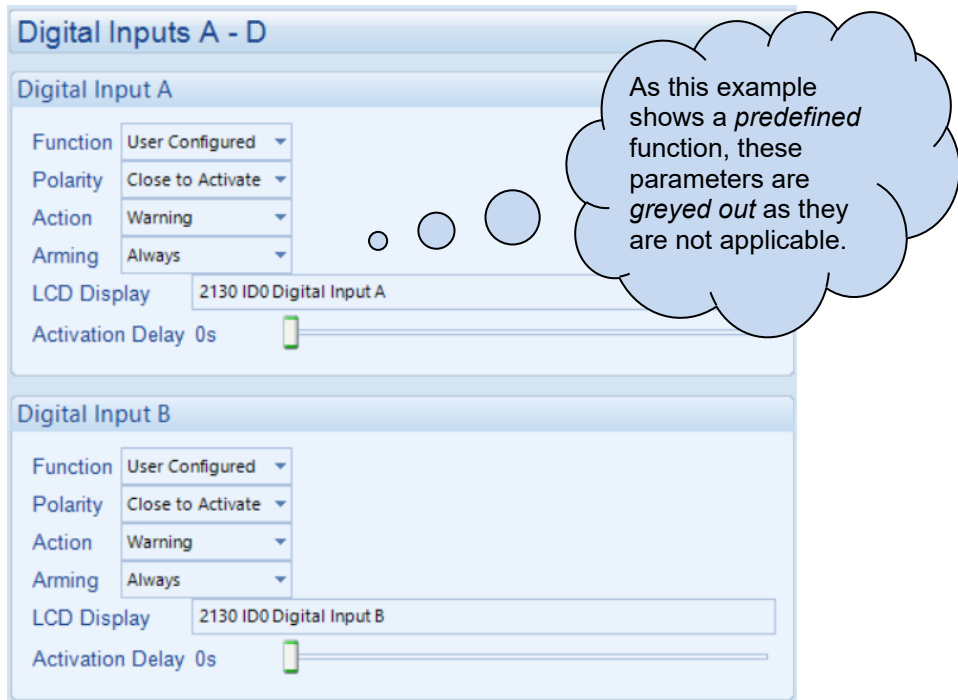

Parameter	Description
Function	Select the input function to activate when the relevant terminal is energised. For details of all available functions see the section entitled <i>Input Functions</i> elsewhere in this document.
Polarity	Select the digital input polarity: <b>Close to Activate:</b> the input function is activated when the relevant terminal is connected. <b>Open to Activate:</b> the input function is activated when the relevant terminal is disconnected.
Action	<p><b>⚠ NOTE: For details of these, see the section entitled <i>Alarm Types</i> elsewhere in this document.</b></p> <p>Select the type of alarm required from the list:</p> <p><b>Electrical Trip</b>  <b>Indication</b>  <b>Shutdown</b>  <b>Warning</b></p>
Arming	<p><b>⚠ NOTE: For details of these, see the section entitled <i>Alarm Arming</i> elsewhere in this document.</b></p> <p>Select when the input becomes active:</p> <p><b>Active from Mains Parallel</b>  <b>Always</b>  <b>From Safety On</b>  <b>From Starting</b>  <b>Never</b></p>
LCD Display	The text that is displayed on the module's LCD when the input activates and generates an alarm.
Activation Delay	This is used to give a delay on acceptance of the input. Useful for liquid level switches or to mask short term operations of the external switch device.

3.17.1.3.2 ANALOGUE INPUTS

**NOTE:** An analogue input is only configurable as a digital input if it has been configured as Digital Input, refer to section 3.4.1 entitled *Analogue Input Configuration* in this document for further details.

### Analogue Inputs E - H

**Analogue Input E (Digital)**

Function	User Configured
Polarity	Close to Activate
Action	Warning
Arming	Always
LCD Display	2130 ID0 Analogue E (Digital)
Activation Delay 0s	<input type="range"/>

**Analogue Input F (Digital)**

The Analogue Input is not configured as a Digital Input  
To reconfigure, use the 'Analogue Input Configuration' page

Parameter	Description
Function	Select the input function to activate when the relevant terminal is energised. For details of all available functions see the section entitled <i>Input Functions</i> elsewhere in this document.
Polarity	Select the digital input polarity: <b>Close to Activate:</b> the input function is activated when the relevant terminal is connected. <b>Open to Activate:</b> the input function is activated when the relevant terminal is disconnected.
Action	<div style="border: 1px solid black; padding: 2px; margin-bottom: 5px;"> <p><b>NOTE:</b> For details of these, see the section entitled <i>Alarm Types</i> elsewhere in this document.</p> </div> Select the type of alarm required from the list:  <b>Electrical Trip</b> <b>Indication</b> <b>Shutdown</b> <b>Warning</b>
Arming	<div style="border: 1px solid black; padding: 2px; margin-bottom: 5px;"> <p><b>NOTE:</b> For details of these, see the section entitled <i>Alarm Arming</i> elsewhere in this document.</p> </div> Select when the input becomes active:  <b>Active from Mains Parallel</b> <b>Always</b> <b>From Safety On</b> <b>From Starting</b> <b>Never</b>
LCD Display	The text that is displayed on the module's LCD when the input activates and generates an alarm.
Activation Delay	This is used to give a delay on acceptance of the input. Useful for liquid level switches or to mask short term operations of the external switch device.

### 3.17.2 DSE2131 INPUT MODULES

Select the DSENet ID of the input expansion to be configured. The ID of the expansion module is set by rotary decimal switch accessible under the removable cover of the device.



The following options are then shown:

#### 2131 Expansion Enable

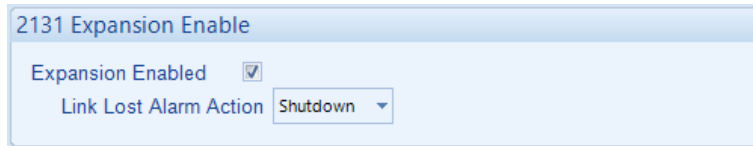

Parameter	Description
Expansion Enabled	<input type="checkbox"/> = The expansion module with the selected ID is not enabled. <input checked="" type="checkbox"/> = The expansion module with the selected ID is enabled. If the expansion module is not connected / detected by the module, the module generates an <i>Exp. Unit Failure</i> alarm with the configured <i>Link Lost Alarm Action</i> severity.
Link Lost Alarm Action	Select the type of alarm required from the list: <b>Electrical Trip:</b> <b>Shutdown:</b> <b>Warning:</b>

#### 2131 Expansion Inputs

The *Expansion Unit* page is then subdivided into smaller sections. Select the required section with the mouse.

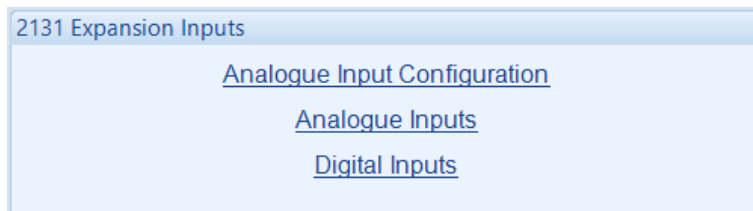

### 3.17.2.1 ANALOGUE INPUT CONFIGURATION

Input Configuration	
Analogue Input A	Flexible Analogue ▾
Analogue Input B	Flexible Analogue ▾
Analogue Input C	Not Used ▾
Analogue Input D	Flexible Analogue ▾
Analogue Input E	Digital Input ▾
Analogue Input F	Digital Input ▾
Analogue Input G	Digital Input ▾
Analogue Input H	Flexible Analogue ▾
Analogue Input I	Digital Input ▾
Analogue Input J	Not Used ▾

#### Input Configuration

Parameter	Description
Analogue Input A to J	Select what the analogue input is to be used for: <b>Not Used:</b> The analogue input is disabled <b>Digital Input:</b> Configured on the <i>2131/Digital Inputs</i> pages <b>Flexible Analogue:</b> Configured on the <i>2131/Analogue Inputs</i> pages

### 3.17.2.2 ANALOGUE INPUTS

**NOTE:** An analogue input is only configurable as a flexible sensor if it has been configured as Flexible Analogue, for further details refer to the section entitled *Analogue Input Configuration* elsewhere in this document.

#### Sensor Description

Sensor Description

Sensor Name

Parameter	Description
Sensor Name	Enter the <i>Sensor Name</i> , this text is shown on the module display when viewing the instrument.

#### Input Type

Input Type

VDO Ohm range (10-180)

Parameter	Description
Input Type	<p>Select the sensor type and curve from a pre-defined list or create a user-defined curve.</p> <p>Available sensor types:  <b>Current:</b> for sensors with maximum range of 0 mA to 20 mA  <b>Resistive:</b> for sensors with maximum range of 0 <math>\Omega</math> to 1920 <math>\Omega</math>  <b>Voltage:</b> for sensors with maximum range of 0 V to 10 V</p> <p>Available parameters to be measured:  <b>Pressure:</b> The input is configured as a pressure sensor  <b>Percentage:</b> The input is configured as a percentage sensor  <b>Temperature:</b> The input is configured as a temperature sensor</p>

**Sensor Alarms**

Parameter	Description
Alarm Arming	<p><b>NOTE:</b> For details of these, see the section entitled <i>Alarm Arming</i> elsewhere in this document.</p> <p>Select when the alarm generated by the analogue input becomes active:  <b>Always</b>  <b>From Safety On</b>  <b>From Starting</b></p>
Low Alarm Enable	<p><input type="checkbox"/> = The Alarm is disabled.  <input checked="" type="checkbox"/> = The <i>Low Alarm</i> activates when the measured quantity drops below the <i>Low Alarm</i> setting.</p>
Low Alarm Action	<p><b>NOTE:</b> For details of these, see the section entitled <i>Alarm Types</i> elsewhere in this document.</p> <p>Select the type of alarm required from the list:  <b>Electrical Trip</b>  <b>Shutdown</b></p>
Low Pre-Alarm Enable	<p><input type="checkbox"/> = The Pre-Alarm is disabled.  <input checked="" type="checkbox"/> = The <i>Low Pre-Alarm</i> is active when the measured quantity drops below the <i>Low Pre-Alarm Trip</i> setting. The <i>Low Pre-Alarm</i> is automatically reset when the measured quantity rises above the configured <i>Low Pre-Alarm Return</i> level.</p>
Low Alarm String	<p>The text that is displayed on the module's LCD when the <i>Low Alarm</i> or <i>Low Pre-Alarm</i> activates.</p>

Parameter descriptions are continued overleaf...

Editing the Configuration

Parameter	Description
High Pre-Alarm Enable	<input type="checkbox"/> = The Pre-Alarm is disabled. <input checked="" type="checkbox"/> = The <i>High Pre-Alarm</i> is active when the measured quantity rises above the <i>High Pre-Alarm Trip</i> setting. The <i>High Pre-Alarm</i> is automatically reset when the measured quantity falls below the configured <i>High Pre-Alarm Return</i> level.
High Alarm Enable	<input type="checkbox"/> = The Alarm is disabled. <input checked="" type="checkbox"/> = The <i>High Alarm</i> is active when the measured quantity rises above the <i>High Alarm</i> setting.
High Alarm Action	<div style="border: 1px solid black; padding: 5px;"> <p> <b>NOTE: For details of these, see the section entitled <i>Alarm Types</i> elsewhere in this document.</b></p> </div> <p>Select the type of alarm required from the list:</p> <p><b><i>Electrical Trip</i></b>  <b><i>Shutdown</i></b></p>
High Alarm String	The text that is displayed on the module's LCD when the <i>High Alarm</i> or <i>High Pre-Alarm</i> activates.

### 3.17.2.3 DIGITAL INPUTS

**NOTE:** An analogue input is only configurable as a digital input if it has been configured as Digital Input, for further details refer to the section entitled *Analogue Input Configuration* elsewhere in this document.

**Analogue Inputs A - C**

**Analogue Input A (Digital)**

Function	Alarm Mute
Polarity	Close to Activate
Action	
Arming	
LCD Display	2131 ID0 Flexible Sensor A
Activation Delay	0s

**Analogue Input B (Digital)**



Function	User Configured
Polarity	Close to Activate
Action	Warning
Arming	Always
LCD Display	2131 ID0 Flexible Sensor B
Activation Delay	0s

**Analogue Input C (Digital)**

The Analogue Input is not configured as a Digital Input  
To reconfigure, use the 'Analogue Input Configuration' page

As this example shows a *predefined* function, these parameters are *greyed out* as they are not applicable.

Parameter descriptions are overleaf...

Parameter	Description
Function	Select the input function to activate when the relevant terminal is energised. See section entitled <i>Input Functions</i> for details of all available functions
Polarity	Select the digital input polarity: <b>Close to Activate:</b> The input function is activated when the relevant terminal is connected. <b>Open to Activate:</b> The input function is activated when the relevant terminal is disconnected.
Action	<div style="border: 1px solid black; padding: 2px;">  <b>NOTE: For details of these, see the section entitled <i>Alarm Types</i> elsewhere in this document.</b> </div> Select the type of alarm required from the list:  <b>Electrical Trip</b> <b>Indication</b> <b>Shutdown</b> <b>Warning</b>
Arming	<div style="border: 1px solid black; padding: 2px;">  <b>NOTE: For details of these, see the section entitled <i>Alarm Arming</i> elsewhere in this document.</b> </div> Select when the input becomes active:  <b>Active from Mains Parallel</b> <b>Always</b> <b>From Safety On</b> <b>From Starting</b> <b>Never</b>
LCD Display	The text that is displayed on the module's LCD when the input activates and generates an alarm.
Activation Delay	This is used to give a delay on acceptance of the input. Useful for liquid level switches or to mask short term operations of the external switch device.

### 3.17.3 DSE2133 INPUT MODULES

Select the DSENet ID of the input expansion to be configured. The ID of the expansion module is set by rotary decimal switch accessible under the removable cover of the device.

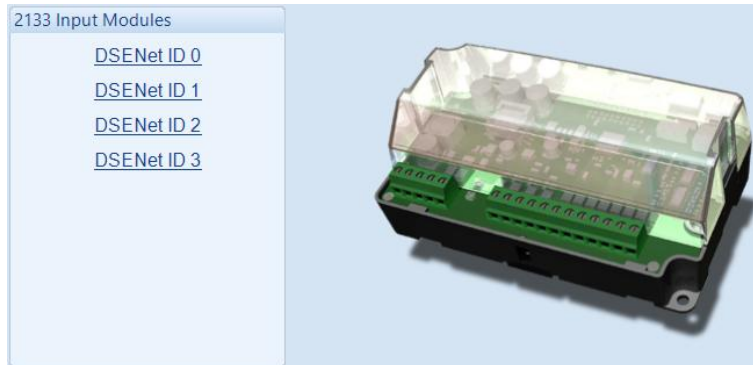

The following options are then shown:

#### 2133 Expansion Enable

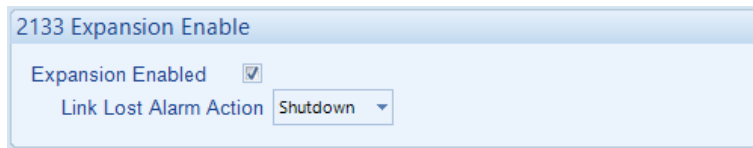

Parameter	Description
Expansion Enabled	<input type="checkbox"/> = The expansion module with the selected ID is not enabled. <input checked="" type="checkbox"/> = The expansion module with the selected ID is enabled. If the expansion module is not connected / detected by the module, the module generates an <i>Exp. Unit Failure</i> alarm with the configured <i>Link Lost Alarm Action</i> severity.
Link Lost Alarm Action	Select the type of alarm required from the list: <b>Electrical Trip:</b> <b>Shutdown:</b> <b>Warning:</b>

#### 2133 Expansion Inputs

The *Expansion Unit* page is then subdivided into smaller sections. Select the required section with the mouse.

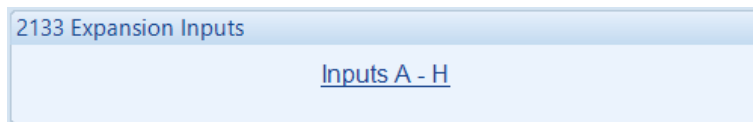

### 3.17.3.1 ANALOGUE INPUTS

**NOTE:** An analogue input is only configurable as a flexible sensor if it has been configured as Flexible Analogue, for further details refer to the section entitled *Analogue Input Configuration* elsewhere in this document.

#### Sensor Description

Sensor Description

Sensor Name

Parameter	Description
Sensor Name	Enter the <i>Sensor Name</i> , this text is shown on the module display when viewing the instrument.

#### Input Type

Input Type

Parameter	Description
Input Type	Select the sensor type from the pre-defined list: <b>2 Wire PT100</b> <b>3 Wire PT100</b> <i>Type J (Thermocouple)</i> <i>Type K (Thermocouple)</i>

**Sensor Alarms**

Parameter	Description
Alarm Arming	<p><b>NOTE:</b> For details of these, see the section entitled <i>Alarm Arming</i> elsewhere in this document.</p> <p>Select when the alarm generated by the analogue input becomes active:  <b>Always</b></p> <p><b>From Safety On</b>  <b>From Starting</b></p>
Low Alarm Enable	<p><input type="checkbox"/> = The Alarm is disabled.  <input checked="" type="checkbox"/> = The <i>Low Alarm</i> activates when the measured quantity drops below the <i>Low Alarm</i> setting.</p>
Low Alarm Action	<p><b>NOTE:</b> For details of these, see the section entitled <i>Alarm Types</i> elsewhere in this document.</p> <p>Select the type of alarm required from the list:  <b>Electrical Trip</b>  <b>Shutdown</b></p>
Low Pre-Alarm Enable	<p><input type="checkbox"/> = The Pre-Alarm is disabled.  <input checked="" type="checkbox"/> = The <i>Low Pre-Alarm</i> is active when the measured quantity drops below the <i>Low Pre-Alarm Trip</i> setting. The <i>Low Pre-Alarm</i> is automatically reset when the measured quantity rises above the configured <i>Low Pre-Alarm Return</i> level.</p>
Low Alarm String	The text that is displayed on the module's LCD when the <i>Low Alarm</i> or <i>Low Pre-Alarm</i> activates.

Parameter descriptions are continued overleaf...

*Editing the Configuration*

Parameter	Description
High Pre-Alarm Enable	<input type="checkbox"/> = The Pre-Alarm is disabled. <input checked="" type="checkbox"/> = The <i>High Pre-Alarm</i> is active when the measured quantity rises above the <i>High Pre-Alarm Trip</i> setting. The <i>High Pre-Alarm</i> is automatically reset when the measured quantity falls below the configured <i>High Pre-Alarm Return</i> level.
High Alarm Enable	<input type="checkbox"/> = The Alarm is disabled. <input checked="" type="checkbox"/> = The <i>High Alarm</i> is active when the measured quantity rises above the <i>High Alarm</i> setting.
High Alarm Action	<div style="border: 1px solid black; padding: 5px;"> <p> <b>NOTE: For details of these, see the section entitled <i>Alarm Types</i> elsewhere in this document.</b></p> </div> <p>Select the type of alarm required from the list:  <b><i>Electrical Trip</i></b>  <b><i>Shutdown</i></b></p>
High Alarm String	The text that is displayed on the module's LCD when the <i>High Alarm</i> or <i>High Pre-Alarm</i> activates.

### 3.17.4 DSE2152 OUTPUT MODULES

Select the DSENet ID of the output expansion to be configured. The ID of the expansion input module is set by rotary decimal switch accessible under the removable cover of the device.



The following options are then shown:

#### 2152 Expansion Enable

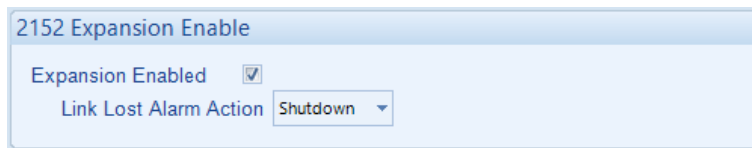

Parameter	Description
Expansion Enabled	<input type="checkbox"/> = The expansion module with the selected ID is not enabled. <input checked="" type="checkbox"/> = The expansion module with the selected ID is enabled. If the expansion module is not connected / detected by the module, the module generates an <i>Exp. Unit Failure</i> alarm with the configured <i>Link Lost Alarm Action</i> severity.
Link Lost Alarm Action	Select the type of alarm required from the list: <b>Electrical Trip:</b> <b>Shutdown:</b> <b>Warning:</b>

#### 2152 Expansion Outputs

The *Expansion Unit* page is then subdivided into smaller sections. Select the required section with the mouse.

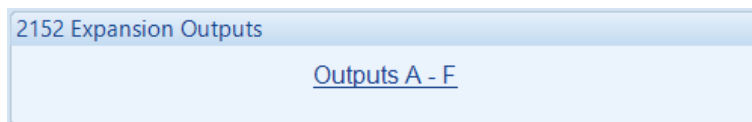

### 3.17.4.1 ANALOGUE OUTPUTS

#### Analogue Output A

##### Output Configuration

Output Name

##### Output Type

Source Curve

Edit...

#### Output Configuration

##### Output Configuration

Output Name

Parameter	Description
Output Name	Enter the <i>Output Name</i> , this text is shown on in the SCADA section when viewing the output.

#### Output Type

##### Output Type

Source Curve

Edit...

Click to edit the 'output curve.' See section entitled *Editing the Output Curve*.

Parameter	Description
Source	Select the parameter that is to be mapped to the analogue output.
Curve	Select the output type and curve from a pre-defined list or create a user-defined curve <b>Current:</b> for sensors with maximum range of 0 mA to 20 mA <b>Voltage:</b> for sensors with maximum range of 0 V to 10 V

### 3.17.4.2 CREATING / EDITING THE OUTPUT CURVE

While the *DSE Configuration Suite* holds specifications for the most used output ranges, occasionally it is required that the expansion module's output be connected to a nonstandard device. To aid this process, a curve editor is provided.

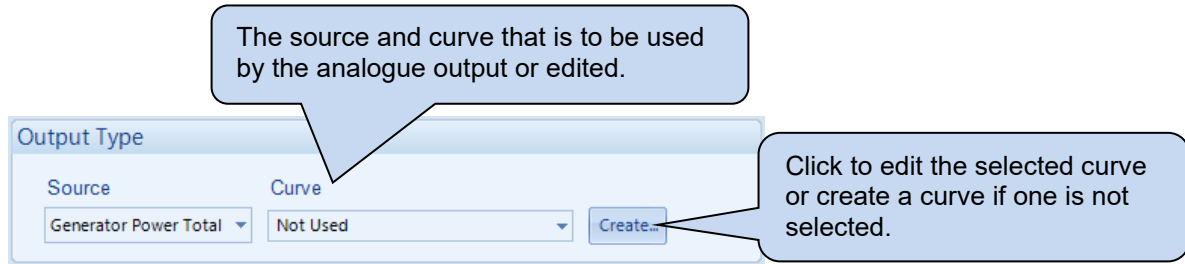

When creating a new sensor curve the measurement quantity and measured parameter are required.

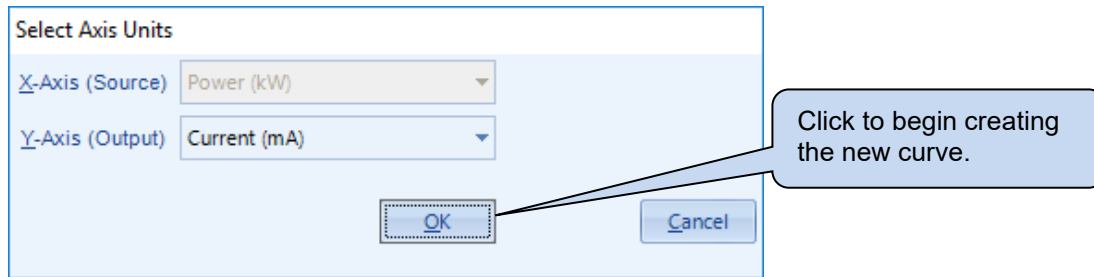

Parameter	Description
Y-Axis (Source)	The parameter measured by the DSE module that is to be mapped to the output.
X-Axis (Output)	Select the electrical quantity that the sensor outputs. <b>Current (mA):</b> For an output current within a range 0 mA to 20 mA <b>Voltage (Volt):</b> For an output voltage within a range of 0 V to 10 V

Curve creation and editor descriptions are continued overleaf...

## Editing the Configuration

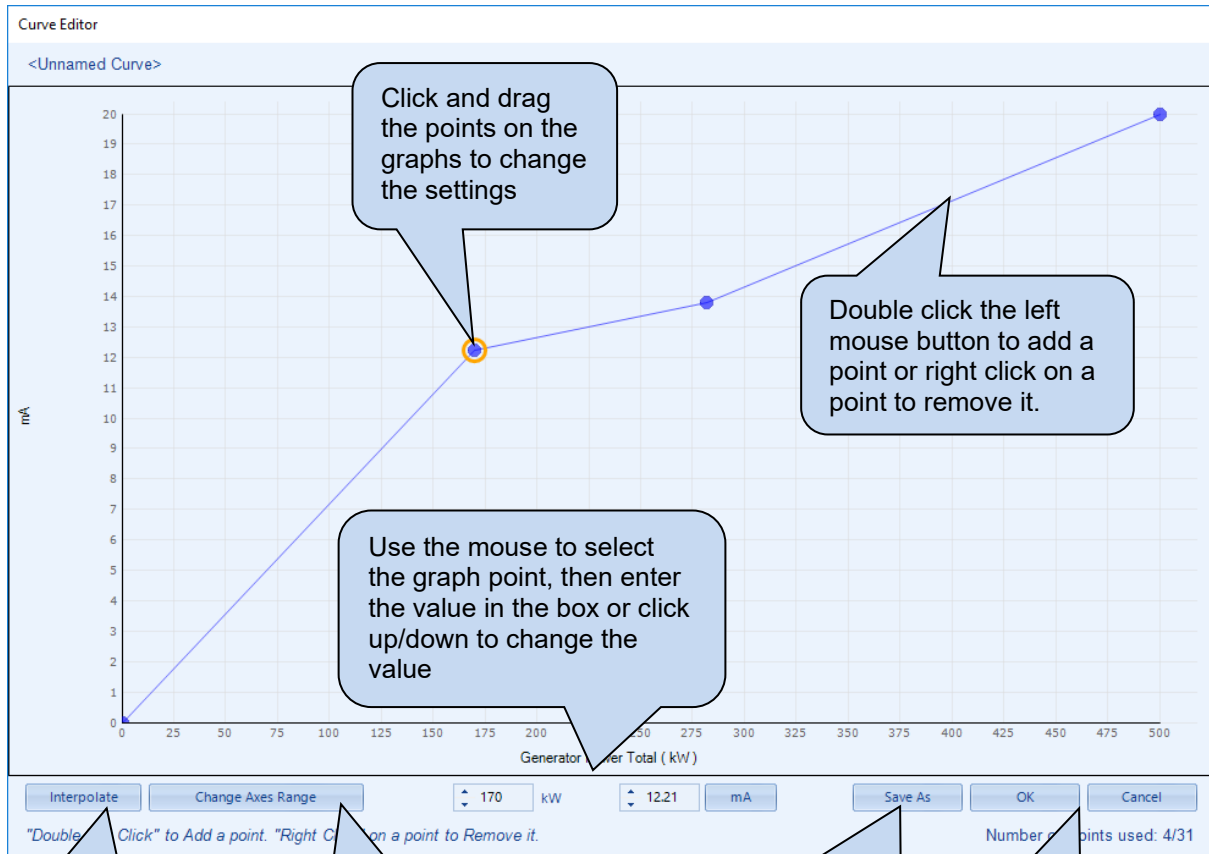

Click *Interpolate* then select two points as prompted to draw a straight line between

Click to change the range of the X and Y Axes of the graph and the level of open circuit

Click SAVE Multi Set, a prompt to name the curve...

New Curve Name

Enter a name for the new curve

OK Cancel

Click OK to accept the changes or CANCEL to ignore and lose the

Click OK to save the curve.

**Any saved curves become selectable in the *Output Type* selection list.**

**Hint:** Deleting, renaming, or editing custom curves that have been added is performed in the main menu, select *Tools | Curve Manager*.

### 3.17.5 DSE2157 RELAY MODULES

Select the DSENet ID of the output expansion to be configured. The ID of the expansion module is set by rotary decimal switch accessible under the removable cover of the device.

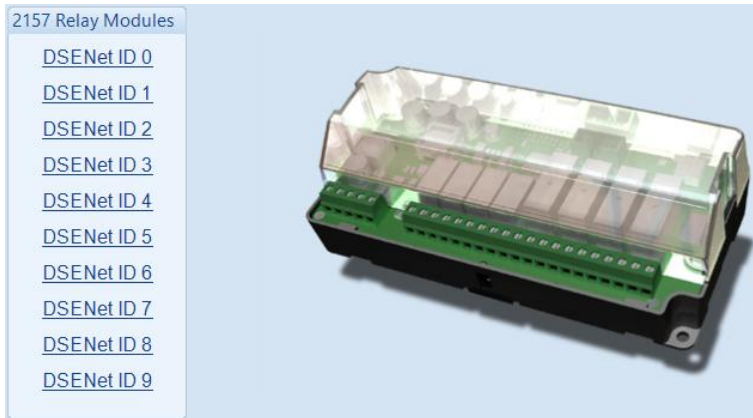

The following options are then shown:

#### 2152 Expansion Enable

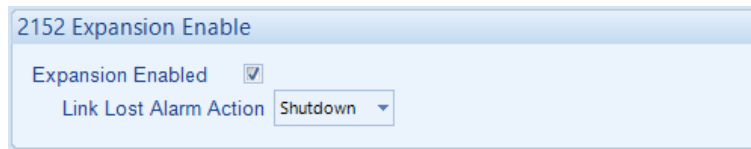

Parameter	Description
Expansion Enabled	<input type="checkbox"/> = The expansion module with the selected ID is not enabled. <input checked="" type="checkbox"/> = The expansion module with the selected ID is enabled. If the expansion module is not connected / detected by the module, the module generates an <i>Exp. Unit Failure</i> alarm with the configured <i>Link Lost Alarm Action</i> severity.
Link Lost Alarm Action	Select the type of alarm required from the list: <b>Electrical Trip:</b> <b>Shutdown:</b> <b>Warning:</b>

#### Relay Outputs (Normally Open / Changeover)

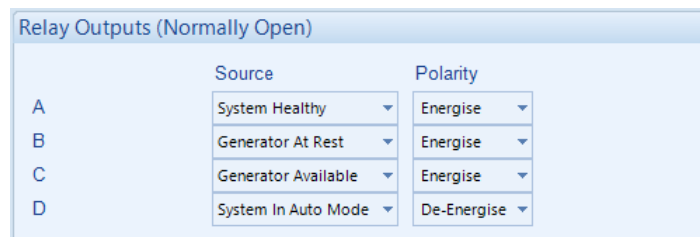

Parameter	Description
Source	Select the output source to control the state of the output For details of all available functions see section entitled <i>Output Sources</i> elsewhere in this document.
Polarity	Select the digital input polarity: <b>Energise:</b> When the output source is true, the output activates. <b>De-Energise:</b> When the output source is true, the output deactivates.

### 3.17.6 DSE2548 ANNUNCIATOR MODULES

Select the DSENet ID of the LED expansion to be configured. The ID of the expansion input module is set by rotary decimal switch accessible on the rear of the device.



The following options are then shown:

#### 2548 Expansion Enable

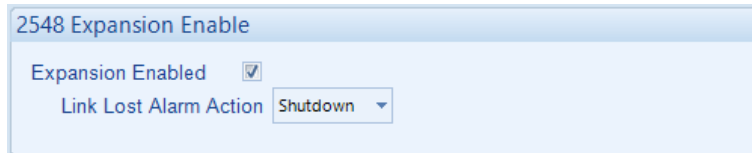

Parameter	Description
Expansion Enabled	<input type="checkbox"/> = The expansion module with the selected ID is not enabled. <input checked="" type="checkbox"/> = The expansion module with the selected ID is enabled. If the expansion module is not connected or detected by the module, the module generates an <i>Exp. Unit Failure</i> alarm with the configured <i>Link Lost Alarm Action</i> severity.
Link Lost Alarm Action	Select the type of alarm required from the list: <b>Electrical Trip:</b> <b>Shutdown:</b> <b>Warning:</b>

**Sounder Configuration**

Sounder Configuration

Follow main unit

Sounder enabled

Parameter	Description
Follow Main Unit	<p><input type="checkbox"/> = If the <i>mute / lamp test</i> button is pressed, other DSE2548 modules and the host module does not respond to this.</p> <p><input checked="" type="checkbox"/> = If the <i>mute / lamp test</i> button is pressed, other DSE2548 modules configured to <i>Follow main unit</i>, and the host module also lamp test / mute their alarm and vice-versa.</p>
Sounder Enabled	<p><input type="checkbox"/> = The DSE2548 internal sounder does not annunciate on a fault condition becoming active.</p> <p><input checked="" type="checkbox"/> = The DSE2548 internal sounder annunciates on a fault condition becoming active.</p>

**LED Indicators**

Indicator	Source	Polarity
A	System In Auto Mode	Unlit
B	Generator Load Inhibited	Lit
C	Combined Remote Start Request	Lit
D	Common Alarm	Lit
E	Not Used	Lit
F	Not Used	Lit
G	Not Used	Lit
H	Not Used	Lit

Annunciator Insert Card

Parameter	Description
Source	Select the output source to control the state of the output For details of all available functions see section entitled <i>Output Sources</i> elsewhere in this document.
Polarity	Select the digital input polarity: <b>Lit:</b> When the output source is true, the output is Lit. <b>Unlit:</b> When the output source is true, the output is Unlit.
Annunciator Insert Card	Allows the user to create and print the custom text insert cards for the LEDs.

### 3.17.7 DSE2160 INPUT MODULE

Select the DSENet ID of the output expansion to be configured. The ID of the expansion module is set by rotary decimal switch accessible under the removable cover of the device.

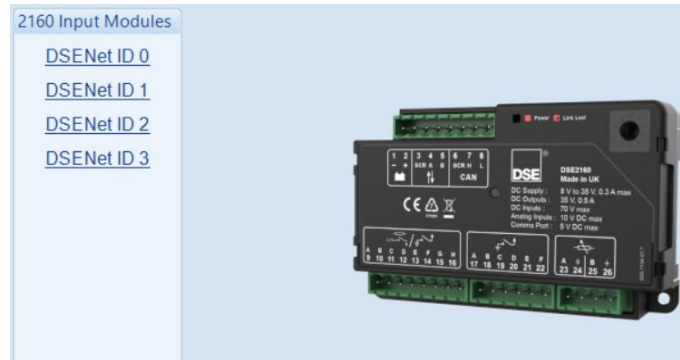

The following options are then shown:

#### 2160 Expansion Enable

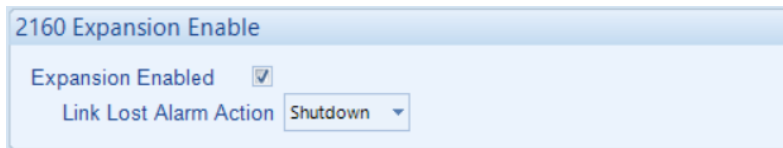

Parameter	Description
Expansion Enabled	<input type="checkbox"/> = The expansion module with the selected ID is not enabled. <input checked="" type="checkbox"/> = The expansion module with the selected ID is enabled. If the expansion module is not connected / detected by the module, the module generates an <i>Exp. Unit Failure</i> alarm with the configured <i>Link Lost Alarm Action</i> severity.
Link Lost Alarm Action	Select the type of alarm required from the list: <b>Electrical Trip:</b> <b>Shutdown:</b> <b>Warning:</b>

#### Expansion

The *Expansion* page is then subdivided into smaller sections. Select the required section with the mouse.

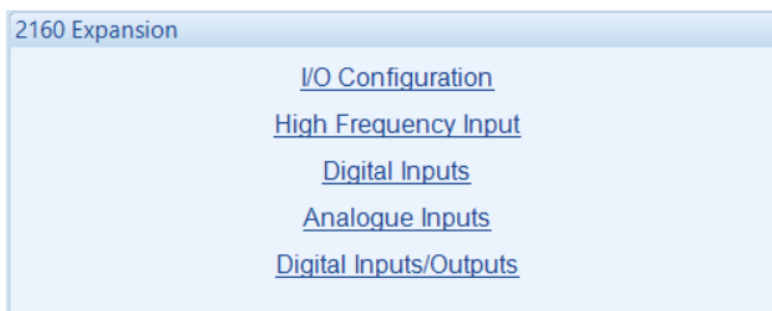

### 3.17.7.1 I/O CONFIGURATION

#### Digital Input A

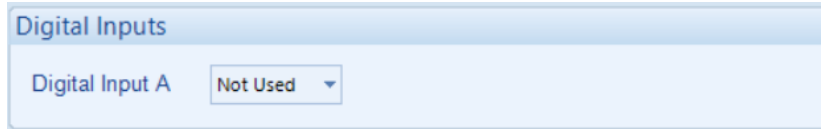

Parameter	Description
Digital Input A	Select the input source from the list.  <i>Not Used</i> <i>Digital Input</i> <i>Frequency Input</i> <i>Pulse Counter</i> <i>RPM Input</i>

#### Analogue Inputs

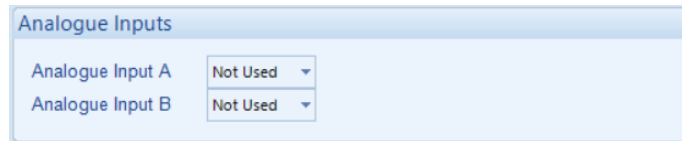

Parameter	Description
Analogue Input A & B	Select the input source from the list.  <i>Not Used</i> <i>Digital Input</i> <i>Flexible Analogue</i>

#### Digital Inputs/Outputs



Parameter	Description
Digital Input/Output A to H	Select the input source from the list.  <i>Not Used</i> <i>Digital Input</i> <i>Digital Output – Negative Switching</i> <i>Digital Output – Positive Switching</i>

### 3.17.7.2 HIGH FREQUENCY INPUT

#### Input Description

**Input Description**

Input Name

Parameter	Description
Input Name	Enter the <i>Input Name</i> , this text is shown on the module display when viewing the instrument.

#### Pulse Counter

**Pulse Counter**

Suffix

Multiplier

1 counter pulse equates to 1.00  
Counter range 0..2,147,483,639

Parameter	Description
Suffix	Unit display (example: m <sup>3</sup> /hr)
Multiplier	Enter the amount to scale each pulse value.

#### RPM Input

**RPM Input**



Pulses per Revolution

Parameter	Description
Pulse per Revolution	Enter the number of pulses generated per revolution to enable accurate RPM calculation from the input signal.

**Input Alarms**

Parameter	Description
Alarm Arming	<p><b>▲NOTE:</b> For details of these, see the section entitled <i>Alarm Arming</i> elsewhere in this document.</p> <p>Select when the alarm generated by the analogue input becomes active:  <b>Always</b>  <b>From Safety On</b>  <b>From Starting</b></p>
Low Alarm Enable	<p><input type="checkbox"/> = The Alarm is disabled.  <input checked="" type="checkbox"/> = The <i>Low Alarm</i> activates when the measured quantity drops below the <i>Low Alarm</i> setting.</p>

Parameter descriptions are continued overleaf...

Parameter	Description
Low Alarm Action	<p> <b>NOTE: For details of these, see the section entitled <i>Alarm Types</i> elsewhere in this document.</b></p> <p>Select the type of alarm required from the list:  <b><i>Electrical Trip</i></b>  <b><i>Shutdown</i></b></p>
Low Pre-Alarm Enable	<p><input type="checkbox"/> = The Pre-Alarm is disabled.  <input checked="" type="checkbox"/> = The <i>Low Pre-Alarm</i> is active when the measured quantity drops below the <i>Low Pre-Alarm Trip</i> setting. The <i>Low Pre-Alarm</i> is automatically reset when the measured quantity rises above the configured <i>Low Pre-Alarm Return</i> level.</p>
Low Alarm String	The text that is displayed on the module's LCD when the <i>Low Alarm</i> or <i>Low Pre-Alarm</i> activates.
High Pre-Alarm Enable	<p><input type="checkbox"/> = The Pre-Alarm is disabled.  <input checked="" type="checkbox"/> = The <i>High Pre-Alarm</i> is active when the measured quantity rises above the <i>High Pre-Alarm Trip</i> setting. The <i>High Pre-Alarm</i> is automatically reset when the measured quantity falls below the configured <i>High Pre-Alarm Return</i> level.</p>
High Alarm Enable	<p><input type="checkbox"/> = The Alarm is disabled.  <input checked="" type="checkbox"/> = The <i>High Alarm</i> is active when the measured quantity rises above the <i>High Alarm</i> setting.</p>
High Alarm Action	<p> <b>NOTE: For details of these, see the section entitled <i>Alarm Types</i> elsewhere in this document.</b></p> <p>Select the type of alarm required from the list:  <b><i>Electrical Trip</i></b>  <b><i>Shutdown</i></b></p>
High Alarm String	The text that is displayed on the module's LCD when the <i>High Alarm</i> or <i>High Pre-Alarm</i> activates.

### **3.17.7.3 DIGITAL INPUTS**

The *Digital Inputs* page is then subdivided into smaller sections. Select the required section with the mouse.

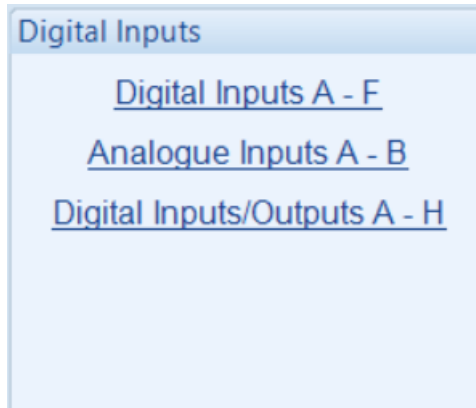

**Digital Inputs A to F**

The image shows two identical configuration panels for Digital Input A and Digital Input B. Each panel includes the following settings:

- Function:** User Configured
- Polarity:** Close to Activate
- Action:** Warning
- Arming:** Always
- LCD Display:** 2160 ID0 Digital Input A (for A) / 2160 ID0 Digital Input B (for B)
- Activation Delay:** 0s, with a slider control.

Parameter	Description
Function	Select the input function to activate when the relevant terminal is energised. See section entitled <i>Input Functions</i> for details of all available functions
Polarity	Select the digital input polarity: <b>Close to Activate:</b> The input function is activated when the relevant terminal is connected. <b>Open to Activate:</b> The input function is activated when the relevant terminal is disconnected.
Action	<div style="border: 1px solid black; padding: 2px;"> <p><b>⚠ NOTE: For details of these, see the section entitled <i>Alarm Types</i> elsewhere in this document.</b></p> </div> <p>Select the type of alarm required from the list:</p> <p><b>Electrical Trip</b>  <b>Indication</b>  <b>Shutdown</b>  <b>Warning</b></p>
Arming	<div style="border: 1px solid black; padding: 2px;"> <p><b>⚠ NOTE: For details of these, see the section entitled <i>Alarm Arming</i> elsewhere in this document.</b></p> </div> <p>Select when the input becomes active:</p> <p><b>Active from Mains Parallel</b>  <b>Always</b>  <b>From Safety On</b>  <b>From Starting</b>  <b>Never</b></p>
LCD Display	The text that is displayed on the module's LCD when the input activates and generates an alarm.
Activation Delay	This is used to give a delay on acceptance of the input. Useful for liquid level switches or to mask short term operations of the external switch device.

### 3.17.7.4 ANALOGUE INPUTS

The *Analogue Inputs* page is then subdivided into smaller sections. Select the required section with the mouse.

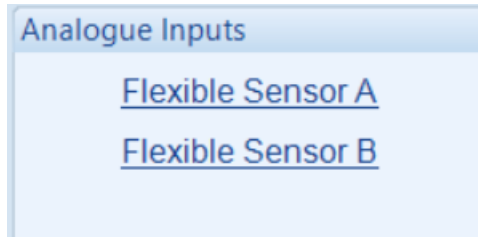

#### Sensor Description

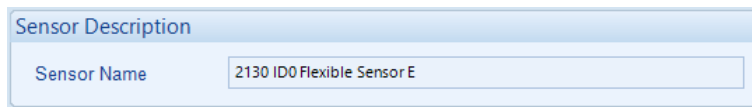

Parameter	Description
Sensor Name	Enter the <i>Sensor Name</i> , this text is shown on the module display when viewing the instrument.

#### Input Type

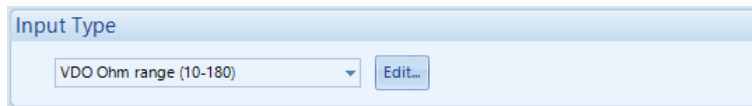

Parameter	Description
Input Type	<p>Select the sensor type and curve from a pre-defined list or create a user-defined curve.</p> <p>Available sensor types:  <b>Resistive:</b> for sensors with maximum range of 0 <math>\Omega</math> to 3 k <math>\Omega</math></p> <p>Available parameters to be measured:  <b>Pressure:</b> The input is configured as a pressure sensor  <b>Percentage:</b> The input is configured as a percentage sensor  <b>Temperature:</b> The input is configured as a temperature sensor</p>

**Sensor Fault Alarm**

**Sensor Fault Alarm**

Enable Alarm

Alarm String

**Sensor Alarms**

**Sensor Alarms**

Alarm Arming Always

Low Alarm Enable

    Action Shutdown

    Low Alarm 25 %

Low Pre-alarm Enable

    Low Pre-alarm Trip 51 %

    Low Pre-alarm Return 76 %

Low Alarm String

High Pre-alarm Enable

    High Pre-alarm Return 127 %

    High Pre-alarm Trip 153 %

High Alarm Enable

    Action Shutdown

    High Alarm 204 %

High Alarm String

Parameter	Description
Alarm Arming	<p><b>NOTE:</b> For details of these, see the section entitled <i>Alarm Arming</i> elsewhere in this document.</p> <p>Select when the alarm generated by the analogue input becomes active:  <b>Always</b>  <b>From Safety On</b>  <b>From Starting</b></p>
Low Alarm Enable	<p><input type="checkbox"/> = The Alarm is disabled.  <input checked="" type="checkbox"/> = The <i>Low Alarm</i> activates when the measured quantity drops below the <i>Low Alarm</i> setting.</p>
Low Alarm Action	<p><b>NOTE:</b> For details of these, see the section entitled <i>Alarm Types</i> elsewhere in this document.</p> <p>Select the type of alarm required from the list:  <b>Electrical Trip</b>  <b>Shutdown</b></p>
Low Pre-Alarm Enable	<p><input type="checkbox"/> = The Pre-Alarm is disabled.  <input checked="" type="checkbox"/> = The <i>Low Pre-Alarm</i> is active when the measured quantity drops below the <i>Low Pre-Alarm Trip</i> setting. The <i>Low Pre-Alarm</i> is automatically reset when the measured quantity rises above the configured <i>Low Pre-Alarm Return</i> level.</p>
Low Alarm String	The text that is displayed on the module's LCD when the <i>Low Alarm</i> or <i>Low Pre-Alarm</i> activates.

Parameter descriptions are overleaf...

Parameter	Description
High Pre-Alarm Enable	<input type="checkbox"/> = The Pre-Alarm is disabled. <input checked="" type="checkbox"/> = The <i>High Pre-Alarm</i> is active when the measured quantity rises above the <i>High Pre-Alarm Trip</i> setting. The <i>High Pre-Alarm</i> is automatically reset when the measured quantity falls below the configured <i>High Pre-Alarm Return</i> level.
High Alarm Enable	<input type="checkbox"/> = The Alarm is disabled. <input checked="" type="checkbox"/> = The <i>High Alarm</i> is active when the measured quantity rises above the <i>High Alarm</i> setting.
High Alarm Action	<div style="border: 1px solid black; padding: 5px;"> <p><b>NOTE:</b> For details of these, see the section entitled <i>Alarm Types</i> elsewhere in this document.</p> </div> <p>Select the type of alarm required from the list:</p> <p><b><i>Electrical Trip Shutdown</i></b></p>
High Alarm String	The text that is displayed on the module's LCD when the <i>High Alarm</i> or <i>High Pre-Alarm</i> activates.

### 3.17.7.5 DIGITAL INPUTS/OUTPUTS

**Digital Outputs**

	Source	Polarity
Output A	Not Used ▾	Energise ▾
Output B	Not Used ▾	Energise ▾
Output C	Not Used ▾	Energise ▾
Output D	Not Used ▾	Energise ▾
Output E	Not Used ▾	Energise ▾
Output F	Not Used ▾	Energise ▾
Output G	Not Used ▾	Energise ▾
Output H	Not Used ▾	Energise ▾

Parameter	Description
Source	Select the output source to control the state of the output For details of all available functions see the section entitled <i>Output Sources</i> elsewhere in this document.
Polarity	Select the digital output polarity: <b><i>De-Energise:</i></b> When the output source is true, the output deactivates. <b><i>Energise:</i></b> When the output source is true, the output activates.

### 3.17.8 DSE2170 INPUT MODULE

Select the DSENet ID of the output expansion to be configured. The ID of the expansion module is set by rotary decimal switch accessible under the removable cover of the device.

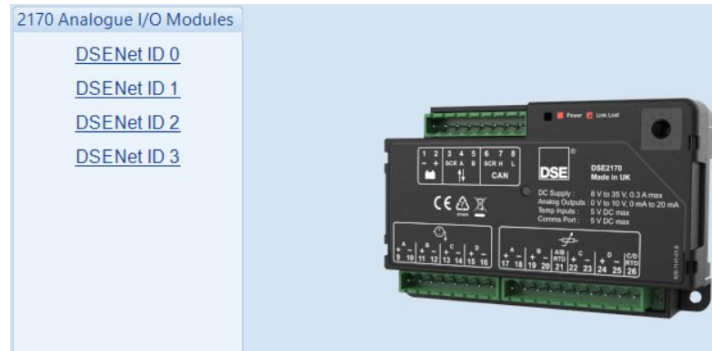

The following options are then shown:

#### 2170 Expansion Enable

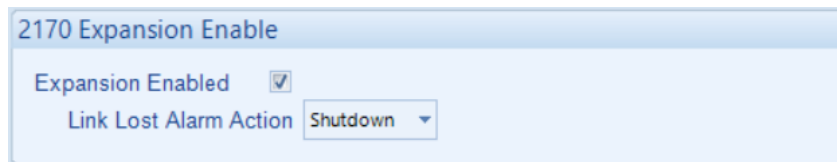

Parameter	Description
Expansion Enabled	<input type="checkbox"/> = The expansion module with the selected ID is not enabled. <input checked="" type="checkbox"/> = The expansion module with the selected ID is enabled. If the expansion module is not connected / detected by the module, the module generates an <i>Exp. Unit Failure</i> alarm with the configured <i>Link Lost Alarm Action</i> severity.
Link Lost Alarm Action	Select the type of alarm required from the list: <b>Electrical Trip:</b> <b>Shutdown:</b> <b>Warning:</b>

#### Expansion

The *Expansion* page is then subdivided into smaller sections. Select the required section with the mouse.

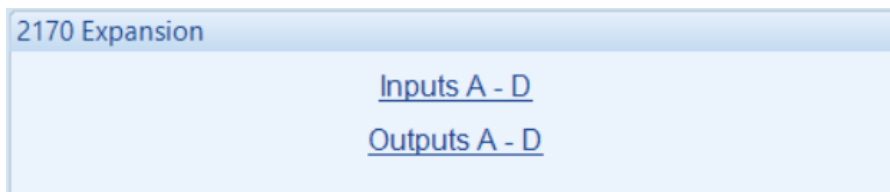

### 3.17.8.1 INPUTS A TO D

The *Inputs A to D* page is then subdivided into smaller sections. Select the required section with the mouse.

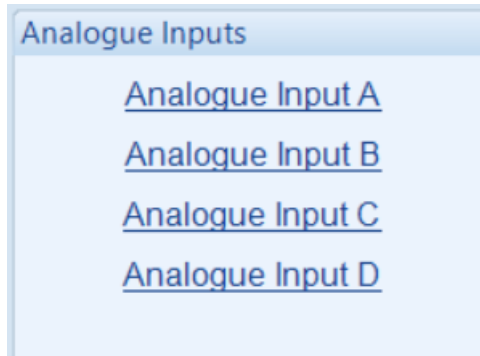

#### Sensor Description

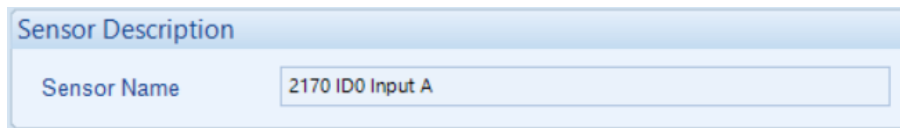

Parameter	Description
Sensor Name	Enter the <i>Sensor Name</i> , this text is shown on the module display when viewing the instrument.

#### Input Type

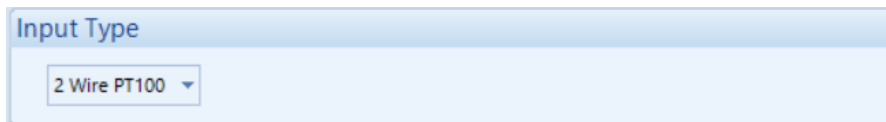

Parameter	Description
Input Type	Select the sensor type from a pre-defined list or create a user-defined curve.  Available sensor types: <b>Not used</b> <b>2 Wire PT100</b> <b>2 Wire PT1000</b> <b>3 Wire PT100</b> <b>3 Wire PT1000</b> <b>Type J</b> <b>Type K</b> <b>Type L</b>

**Sensor Alarms**

Parameter	Description
Alarm Arming	<p><b>NOTE:</b> For details of these, see the section entitled <i>Alarm Arming</i> elsewhere in this document.</p> <p>Select when the alarm generated by the analogue input becomes active:  <b>Always</b>  <b>From Safety On</b>  <b>From Starting</b></p>
Low Alarm Enable	<p><input type="checkbox"/> = The Alarm is disabled.  <input checked="" type="checkbox"/> = The <i>Low Alarm</i> activates when the measured quantity drops below the <i>Low Alarm</i> setting.</p>
Low Alarm Action	<p><b>NOTE:</b> For details of these, see the section entitled <i>Alarm Types</i> elsewhere in this document.</p> <p>Select the type of alarm required from the list:  <b>Electrical Trip</b>  <b>Shutdown</b></p>
Low Pre-Alarm Enable	<p><input type="checkbox"/> = The Pre-Alarm is disabled.  <input checked="" type="checkbox"/> = The <i>Low Pre-Alarm</i> is active when the measured quantity drops below the <i>Low Pre-Alarm Trip</i> setting. The <i>Low Pre-Alarm</i> is automatically reset when the measured quantity rises above the configured <i>Low Pre-Alarm Return</i> level.</p>
Low Alarm String	The text that is displayed on the module's LCD when the <i>Low Alarm</i> or <i>Low Pre-Alarm</i> activates.

Parameter descriptions are overleaf...

Editing the Configuration

Parameter	Description
High Pre-Alarm Enable	<input type="checkbox"/> = The Pre-Alarm is disabled. <input checked="" type="checkbox"/> = The <i>High Pre-Alarm</i> is active when the measured quantity rises above the <i>High Pre-Alarm Trip</i> setting. The <i>High Pre-Alarm</i> is automatically reset when the measured quantity falls below the configured <i>High Pre-Alarm Return</i> level.
High Alarm Enable	<input type="checkbox"/> = The Alarm is disabled. <input checked="" type="checkbox"/> = The <i>High Alarm</i> is active when the measured quantity rises above the <i>High Alarm</i> setting.
High Alarm Action	<div style="border: 1px solid black; padding: 5px;"> <p> <b>NOTE: For details of these, see the section entitled <i>Alarm Types</i> elsewhere in this document.</b></p> </div> <p>Select the type of alarm required from the list:</p> <p><b><i>Electrical Trip</i></b>  <b><i>Shutdown</i></b></p>
High Alarm String	The text that is displayed on the module's LCD when the <i>High Alarm</i> or <i>High Pre-Alarm</i> activates.

### 3.17.8.2 OUTPUTS A TO D

The *Outputs A to D* page is then subdivided into smaller sections. Select the required section with the mouse.

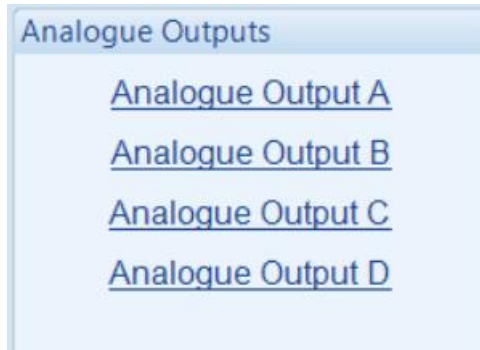

#### Output Configuration

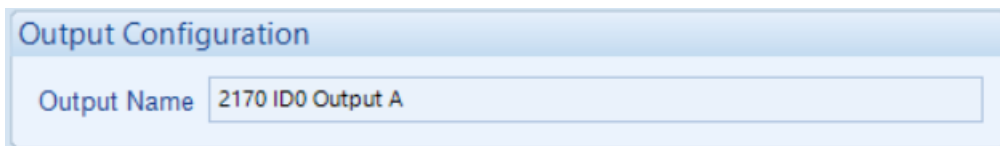

Parameter	Description
Output Name	Enter the <i>Output Name</i> , this text is shown on in the SCADA section when viewing the output.

#### Output Type

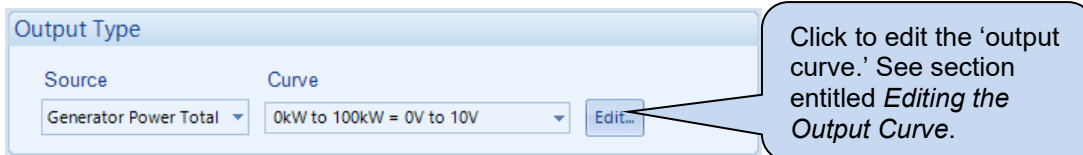

Parameter	Description
Source	Select the parameter that is to be mapped to the analogue output.
Curve	Select the output type and curve from a pre-defined list or create a user-defined curve <b>Current:</b> for sensors with maximum range of 0 mA to 20 mA <b>Voltage:</b> for sensors with maximum range of 0 V to 10 V

### 3.17.8.3 CREATING / EDITING THE OUTPUT CURVE

While the *DSE Configuration Suite* holds specifications for the most used output ranges, occasionally it is required that the expansion module's output be connected to a nonstandard device. To aid this process, a curve editor is provided.

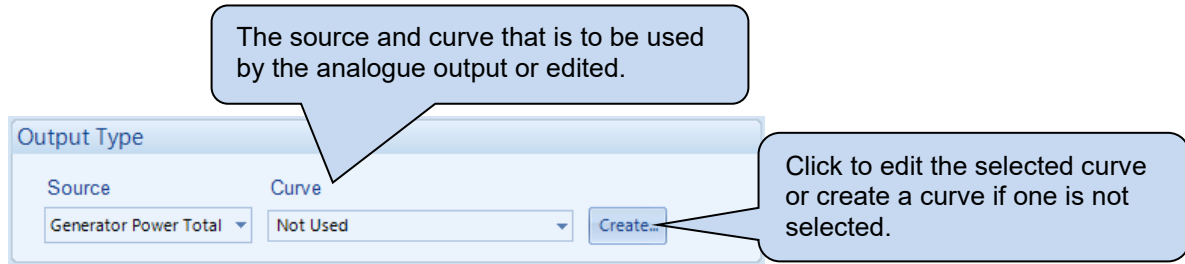

When creating a new sensor curve the measurement quantity and measured parameter are required.

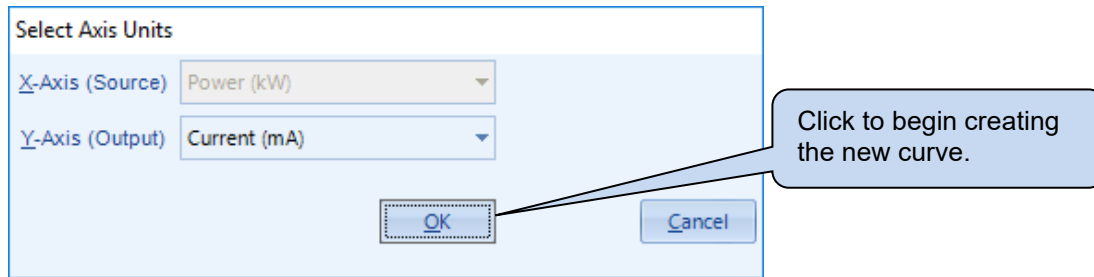

Parameter	Description
Y-Axis (Source)	The parameter measured by the DSE module that is to be mapped to the output.
X-Axis (Output)	Select the electrical quantity that the sensor outputs. <b>Current (mA):</b> For an output current within a range 0 mA to 20 mA <b>Voltage (Volt):</b> For an output voltage within a range of 0 V to 10 V

Curve creation and editor descriptions are continued overleaf...

## Editing the Configuration

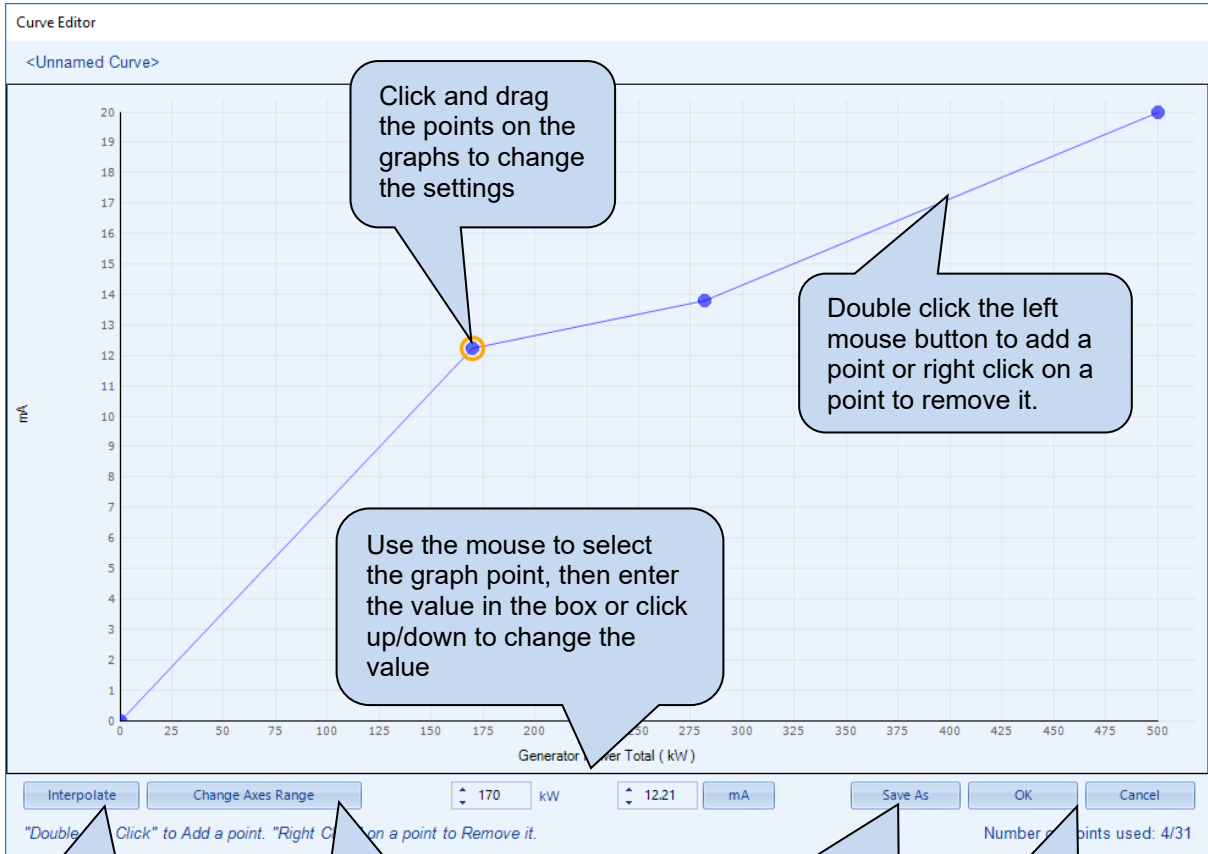

Click *Interpolate* then select two points as prompted to draw a straight line between

Click to change the range of the X and Y Axes of the graph and the level of open circuit

Click SAVE Multi Set, a prompt to name the curve...

**New Curve Name**

Enter a name for the new curve

Click OK to save the curve.

**Any saved curves become selectable in the *Output Type* selection list.**

Click OK to accept the changes or CANCEL to ignore and lose the

**Hint:** Deleting, renaming, or editing custom curves that have been added is performed in the main menu, select *Tools | Curve Manager*.

### 3.17.9 BATTERY CHARGERS

Select the DSENet ID of the battery charger to be configured. The ID of the expansion module is set by configuration of the device.



The following options are then shown:

#### DSENet ID

**DSENet ID 0**

Enable

Link Lost Alarm Action Shutdown

Modbus Server ID 11

Display Instrumentation

Charger Name Charger ID0

Parameter	Description
Enable	<input type="checkbox"/> = The battery charger with the selected ID is not enabled. <input checked="" type="checkbox"/> = The battery charger with the selected ID is enabled. If the expansion module is not connected or detected by the module, the module generates an <i>Exp. Unit Failure</i> alarm with the configured <i>Link Lost Alarm Action</i> severity.
Link Lost Alarm Action	The following Alarm types are:  <b>Shutdown</b> <b>Electrical Trip</b> <b>Warning</b>
Modbus Server ID	The <i>Server ID</i> used to address the battery charger via the host module's RS485 when using the host module as a Modbus RTU pass through.
Display Instrumentation	<input type="checkbox"/> = The battery chargers' information is not shown on the host module's display. <input checked="" type="checkbox"/> = The battery charger information is shown on the host module's display.
Charger Name	Enter the <i>Charger Name</i> , this text is shown on the module display when viewing the battery charger instrumentation

**Charger Shutdown Alarms**

**Charger Shutdown Alarms**

Enable

Module Action Warning

Alarm String Charger ID0 Common Shutdown

Parameter	Description
Enable	<input type="checkbox"/> = The DSE module does not display any shutdown alarms from the battery charger. <input checked="" type="checkbox"/> = The DSE module displays shutdown alarms from the battery charger with the configured action.
Alarm String	The text that is displayed on the module's LCD when the DSE module detects a shutdown fault from the battery charger.

**Charger Warning Alarms**

**Charger Warning Alarms**

Enable

Module Action Warning

Alarm String Charger ID0 Common Warning

Parameter	Description
Enable	<input type="checkbox"/> = The DSE module does not display any warning alarms from the battery charger. <input checked="" type="checkbox"/> = The DSE module displays warnings alarms from the battery charger with the configured action.
Alarm String	The text that is displayed on the module's LCD when the DSE module detects a warning fault from the battery charger.

### 3.17.10 CREATING / EDITING THE SENSOR CURVES

While the *DSE Configuration Suite* holds sensor specifications for the most used resistive sensors, occasionally it is required that the module be connected to a sensor not listed by the *DSE Configuration Suite*. To aid this process, a sensor curve editor is provided.

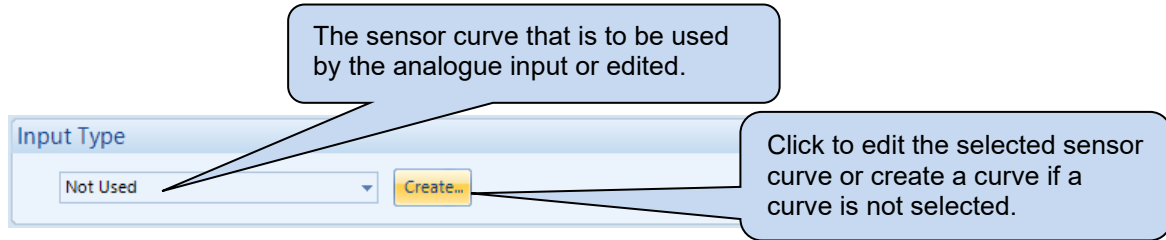

When creating a new sensor curve the measurement quantity and measured parameter are required.

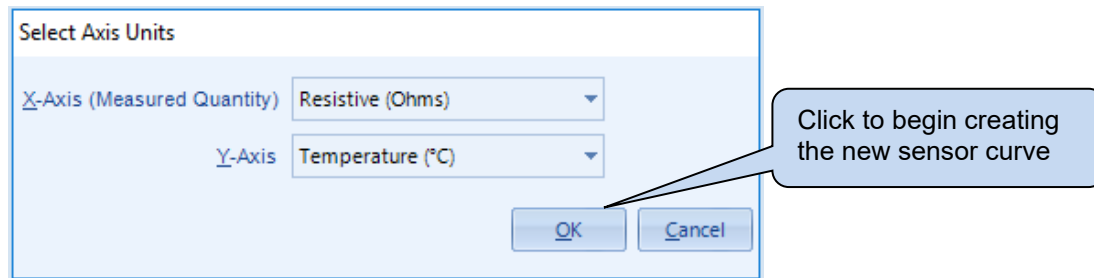

Parameter	Description
X-Axis (Measured Quantity)	Select the electrical quantity that the sensor outputs. <b>Current (mA)</b> : For sensors that output current within a range 0 mA to 20 mA <b>Voltage (0-10 Volts)</b> : For sensors that output voltage within a range of 0 V to 10 V <b>Voltage (0-32 Volts)</b> : For sensors that output voltage within a range of 0 V to 32 V <b>Resistive (Ohms)</b> : For sensors that output a resistance within a range 0 Ω to 3K Ω on Analogue Input A and 0 to 5K Ω on Analogue Inputs B to G
Y-Axis	Select the parameter that is being monitored by the sensor. <b>Temperature (°C)</b> : For sensors that measure temperature. <b>Pressure (Bar)</b> : For sensors that measure pressure. <b>Percentage (%)</b> : For sensors that measure percentage.

Sensor curve creation and editor descriptions are continued overleaf...

## Editing the Configuration

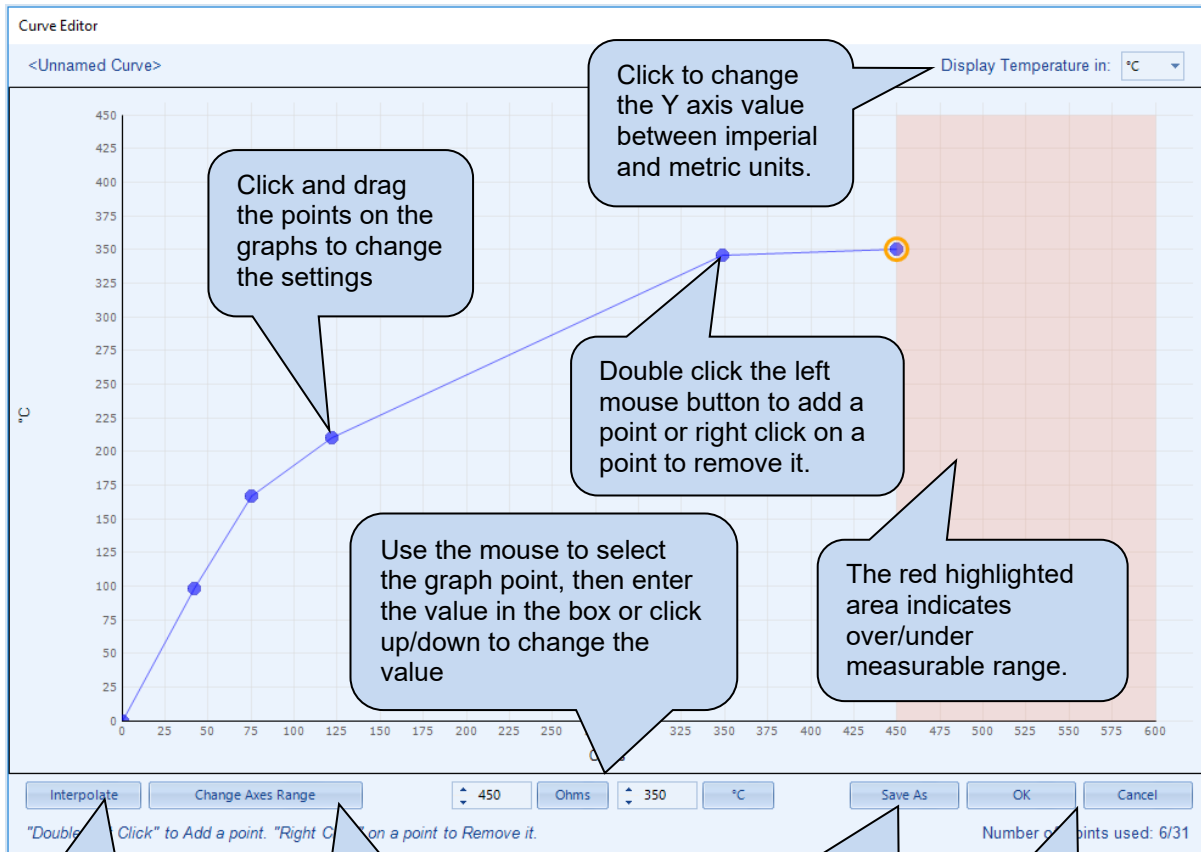

Click *Interpolate* then select two points as prompted to draw a straight line between them.

Click to change the range of the X and Y Axes of the graph and the level of open circuit

Click *Save As* prompt to name the curve...

New Curve Name

Enter a name for the new curve

OK Cancel

Click OK to accept the changes or CANCEL to ignore and lose the

Click OK to save the curve.

**Any saved curves become selectable in the *Input Type* selection list.**

**Hint:** Deleting, renaming, or editing custom sensor curves that have been added is performed in the main menu, select *Tools | Curve & Unit Manager*.

**Change Axis Range Example**

**NOTE:** The difference between the Minimum and Maximum values on the X and Y axis must exceed the noted limits.

The screenshot shows a 'Select Range' dialog box with a graph and configuration fields. The graph plots percentage (%) on the Y-axis (0 to 250) against Ohms on the X-axis (0 to 450). A blue line with four data points shows a linear relationship. Below the graph are three rows of configuration fields for 'X-Axis(Ohms)', 'Y-Axis(%)', and 'X Axis - Fault Threshold'. Each row has 'Minimum' and 'Maximum' spinners. The 'X-Axis(Ohms)' row has a minimum of 0 and a maximum of 480, with a note 'X-Axis range must exceed 200 Ohms'. The 'Y-Axis(%)' row has a minimum of 0 and a maximum of 260, with a note 'Y-Axis range must exceed 200 %'. The 'X Axis - Fault Threshold' row has a minimum of 0 and a maximum of 5000. Callouts explain that the X-axis unit is Ohms, the Y-axis unit is %, and the maximum X-axis value is limited to 5000.

Axis	Minimum	Maximum	Requirement
X-Axis(Ohms)	0	480	X-Axis range must exceed 200 Ohms
Y-Axis(%)	0	260	Y-Axis range must exceed 200 %
X Axis - Fault Threshold	0	5000	

### 3.18 ADVANCED

The *Advanced* page is subdivided into smaller sections. Select the required section with the mouse.



### 3.18.1 ADVANCED OPTIONS

#### Protections

 **WARNING!** - Enabling this feature prevents the set being stopped upon critical alarm conditions. All shutdown alarms are disabled except for EMERGENCY STOP which continues to operate.

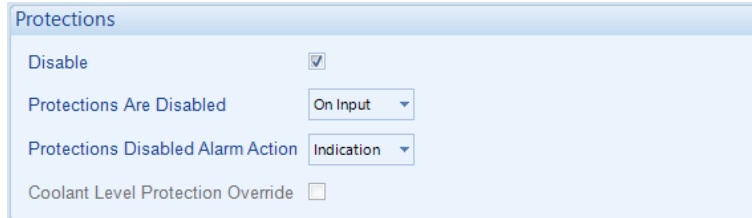

This feature is provided to assist the system designer in meeting specifications for “Warning only,” “Protections Disabled,” “Run to Destruction,” “Battle short Mode” or other similar wording.

Parameter	Description
Disable	<p> <b>NOTE:</b> Writing a configuration to the controller that has “Protections Disabled” configured, results in a warning message appearing on the PC screen for the user to acknowledge before the controller’s configuration is changed. This prevents inadvertent activation of the feature.</p> <p><input type="checkbox"/> = The module operates as normal and provide engine shutdown if required.  <input checked="" type="checkbox"/> = <i>Protections disabled</i> function is activated. Operation depends upon the following configuration.</p>
Protections are disabled	<p><b>Never:</b> The protections are not disabled  <b>Always:</b> Protections are always overridden by the DSE controller.  <b>On Input:</b> Protections are disabled whenever a configurable input set to <i>Protections Disabled</i> is activated</p>
Protections Disabled Alarm Action	<p>If <i>Disable All Protections</i> is set to <i>On Input</i>, this selection allows configuration of an alarm to highlight that the protections have been disabled on the engine.  <b>Indication:</b> Any output or LCD display indicator configured to <i>Protections Disabled</i> is made active; however, the internal alarm sound does not operate.  <b>Warning:</b> Any output or LCD display indicator configured to <i>Protections Disabled</i> is made active, and the internal alarm sound operates.                      When protections are disabled, <i>Protections Disabled</i> appears on the module display to inform the operator of this status.</p>
Coolant Level Protection Override	<p><input type="checkbox"/> = When a CANbus engine is selected, the <i>Coolant Level Protection</i> is provided when supported by the ECU (ECM).  <input checked="" type="checkbox"/> = The <i>Coolant Level Protection</i> is overridden and does not activate an alarm on the module</p>

**Out of Sync**

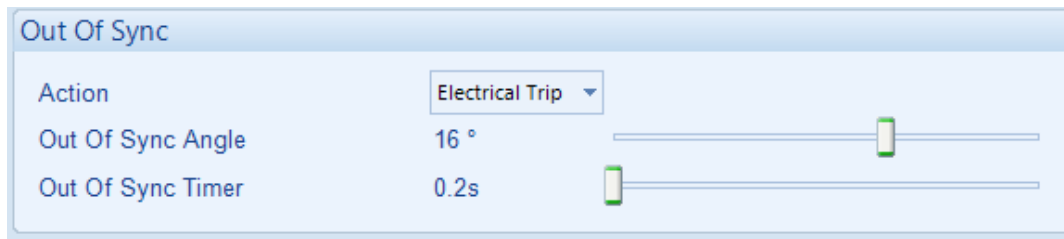

Parameter	Description
Action	<p><b>▲ NOTE: For details of these, see the section entitled <i>Alarm Types</i> elsewhere in this document.</b></p> <p>Select the type of alarm required from the list:</p> <p><b><i>Auxiliary Mains Fail (Single Set)</i></b>  <b><i>Electrical Trip</i></b>  <b><i>Warning</i></b></p>
Out of Sync Angle	<p>During parallel operation, the phase of both supplies is monitored. Being in parallel means that the phase difference is zero degrees (0 °) between the two supplies.</p> <p>If the angle exceeds the <i>Out of Sync Angle</i> for longer than the duration of the <i>Out of Sync Timer</i>, an electrical trip alarm is generated taking the set off load and into the cooling timer, after which the set is stopped.</p>

**Troubleshooting Out of Sync**

This section describes the most common causes for an *Out of Sync* alarm:

- The *Bus or Mains Sensing* connections have not been made between the common generator bus and the DSE module, or the bus or mains sensing fuses have blown or have been removed.
- The load switching device does not close quickly enough. Ensure the breaker closes within 100 ms of receiving the close signal.
- The *Out of Sync* timer is set too low. If this timer is raised away from the factory setting of 200 ms (0.2 s), ensure the consequences are fully understood.
- Something external has caused the breaker to open or has prevented it from closing. Typical examples are external G59 relays and other equipment operating directly on the breaker to open it.
- The breaker wiring 'logic' is not correct, causing the breaker to 'fire through,' where it triggers the close mechanism, but the breaker does not actually mechanically close, it re-opens again.

**Other Timers**

Other Timers

Synchronisation Delay	3s	
Mains Decoupling Supervision	1.0s	

Parameter	Description
Synchronisation Delay	Delays the synchronising process to allow the set to stabilise and power parasitic loads or transformers (for instance) before the synchronising process begins.
Mains Decoupling Supervision	Delays the activation of the inbuilt Mains Decoupling detection when generator switchgear closes and is in parallel with the mains. Upon closing into parallel, the timer is activated. After the timer has expired, the Mains decoupling protection becomes active.

**Other Timers (Single Set)**

Other Timers (Single Set)

Interlock Override Off	0.1s	
------------------------	------	--

Parameter	Description
Interlock Override Off	Timer to delay the <i>Interlock Override</i> de-energising once a breaker has opened.

**Dead Bus Synchronising**

**NOTE:** When using a DSE CAN AVR in a *Dead Bus Synchronising* application, the DSE module can control the “*Alternator De-Excite*” via the CAN communication, ensure the “*De-Excite Mode*” is enabled in the DSE CAN AVR. For further details on the DSE CAN AVRs configuration refer to DSE Publication: 057-283 *DSEA108 Software Manual* or 057-294 *DSEA109 Software Manual* available on our website: [www.deepseaelectronics.com](http://www.deepseaelectronics.com)

**NOTE:** If *Dead Bus Synchronising* is enabled and *Remote Start on Load* input is active then the module chooses the shortest start delay timer setting between the *Remote Start on Load Start Delay* timer and the *Dead Bus Synchronising Start Delay* timer.

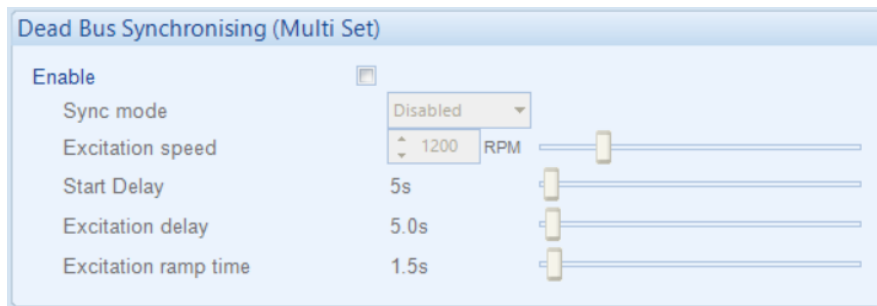

Parameter	Description
Enable	<input type="checkbox"/> = All synchronising is performed ‘the traditional’ way by achieving a slip frequency and waiting for the voltage, frequency, and phase to be within configured windows <input checked="" type="checkbox"/> = The Dead Bus Synchronising feature is activated as configured below.
Sync Mode	<p><b>Always:</b> Dead bus sync is always used when the generators are required to be online and in the <i>Auto</i> mode (Dead bus sync does not operate in <i>Manual</i> mode under any circumstance).</p> <p><b>Disabled:</b> The feature is not active</p> <p><b>On Input:</b> Dead bus sync is used when a digital input configured for <i>Multi Set Controller Dead Bus Synchronising</i> is active.</p> <p><b>On Request From xx60:</b> Dead bus sync is only used when a start request is received from a DSExx60 module.</p>
Excitation Speed	The speed at which the engine is deemed to be running fast enough for the output configured as <i>De-Excite Alternator</i> to be de-energised. Any sets not reaching this speed by the end of the <i>Excitation Delay</i> open their breakers and are removed from the Dead Bus Sync System.
Start Delay	Time delay used at start up to ensure the start request is not simply a fleeting request.
Excitation Delay	During engine run up, if the <i>Excitation Speed</i> is not achieved by the end of the <i>Excitation Delay</i> , the set is removed from the Dead Bus Sync system and attempts to synchronise in the ‘traditional’ way.
Excitation Ramp Time	The time allowed for the excitation field to build after being energised. At the end of this time, all frequency and voltage alarms are active.

**Test Mode (Single Set)**

Test mode (Single Set)

Run Mode Parallel Mode ▾

Parameter	Description
Run Mode	<p>Configures the operation of the <i>Test</i> mode (Single Set) as:</p> <p><b>Island Mode:</b> The module performs the start sequence and transfers all the load to the Generator. The Mains switchgear is left open, and the Generator runs in island mode.</p> <p><b>Parallel Mode:</b> The module performs the start sequence and synchronises the generator Bus to the Mains to allow long term parallel operation; peak lopping when set to <i>Mains Mode</i>, or fixed export / base load when in <i>Generator Mode</i>.</p>

### 3.18.2 AVR

**NOTE:** At the time of writing, only the DSEA108 and DSEA109 AVRs are supported. The software versions of the DSEA108 & DSEA109 must be v2.0 or later. For further details, refer to DSE Publication: *057-281 DSEA108 Operator Manual* or *057-295 DSEA109 Operator Manual* available on our website: [www.deepseaelectronics.com](http://www.deepseaelectronics.com)

**NOTE:** The module's ECU port's baud rate is defined by the engine file selected in the *Application* section. Most engines' ECU baud rates are set to be 250 kb/s, ensure the baud rate of the AVR matches the engine ECU's baud rate.

This feature is to allow the DSE module communicate with a supported CAN AVR through its ECU port, to read the AVR instrumentations and to control the AVR for voltage matching during the synchronisation process and to control the reactive power during the load share.

#### AVR Options

Parameter	Description
Enable AVR CAN Communications	<input type="checkbox"/> = Communications with the CAN AVR is disabled <input checked="" type="checkbox"/> = Enables communication with the CAN AVR through the ECU port.
AVR Type	Select the DSE CAN AVR connected to the module's ECU port. Options are: <ul style="list-style-type: none"> <li>• <b>A108</b></li> <li>• <b>A109</b></li> </ul>
AVR Source Address	<div style="border: 1px solid black; padding: 5px; margin-bottom: 5px;"> <p><b>NOTE:</b> For a full list of the AVR CAN message and instrumentation, refer to DSE Publication: <i>057-281 DSEA108 Operator Manual</i> or <i>057-295 DSEA109 Operator Manual</i> which is found on our website: <a href="http://www.deepseaelectronics.com">www.deepseaelectronics.com</a></p> </div> <div style="border: 1px solid black; padding: 5px; margin-bottom: 5px;"> <p><b>NOTE:</b> For further details on how to configure the DSEA108 CAN Source address, refer to DSE Publication: <i>057-283 DSEA108 Software Manual</i> or <i>057-294 DSEA109 Software Manual</i> which is available on our website: <a href="http://www.deepseaelectronics.com">www.deepseaelectronics.com</a></p> </div> <p>Set the AVR's <i>CAN Source Address</i> to communicate through.</p>
Module CAN Address	The CAN Source address used by the module when sending CAN messages to the AVR.

Parameter descriptions are continued overleaf...

Parameter	Description
Match AVR Alternative Configuration to Controller	<p><b>NOTE:</b> It is the engineer's responsibility to ensure that the DSE module's Alternative Configurations are within the correct range of the CAN AVR's Alternative Configurations. For further details on how to configure the DSEA108 or DSEA109 alternative configurations, refer to DSE Publication: <i>057-283 DSEA108 Software Manual</i> or <i>057-294 DSEA109 Software Manual</i> which is found on our website: <a href="http://www.deepseaelectronics.com">www.deepseaelectronics.com</a></p> <p>This feature is used to send a request to the CAN AVR to switch to an Alternative Configuration. If <i>Alt Config 1</i> is selected in the DSE Module, <i>Alt Config 1</i> is selected in the AVR too regardless of the configured values.</p> <p><input type="checkbox"/> = The module does not send an <i>Alternative Configuration</i> request to the CAN AVR.  <input checked="" type="checkbox"/> = The module sends an <i>Alternative Configuration</i> request to the CAN AVR when required.</p>
Disable CAN Voltage Control	<p><input type="checkbox"/> = The DSE module controls the AVR through the CAN communication. During the synchronisation process the DSE module controls the voltage through the CAN, and when load sharing it controls the reactive power through the CAN.  <input checked="" type="checkbox"/> = The DSE module CAN Voltage Control is disabled. The DSE module does not control the AVR through the CAN communication for voltage matching and does not control the reactive power through the CAN when load sharing.</p>

**AVR Data Fail**

Indicates CAN communication failure between the module and the CAN AVR.

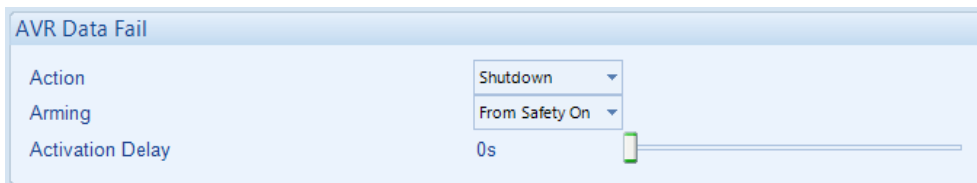

Parameter	Description
Action	Select the action to take when the module detects a communication failure with the CAN AVR. The options are: <b>Electrical Trip</b> <b>None</b> <b>Shutdown</b> <b>Warning</b>
Arming	Select when the <i>AVR Data Fail</i> is monitored.  Options are as follows: <b>Always:</b> The alarm is active at any time the CAN Link is lost <b>From Safety On:</b> Active only after the <i>Safety On</i> delay timer <b>From Starting:</b> Active only after the <i>Crank Relay</i> is energised <b>Loading Alarms Activation:</b> The alarm is monitored after the generator is running, and the voltage and frequency are above their <i>Loading</i> levels, until the generator stops.
Activation Delay	The time delay for the module to wait before activating <i>AVR Data Fail</i> alarm when detected.

**AVR Fault**

Parameter	Description
Action	Select the action to take after the <i>Activation Delay</i> timer, when the CAN AVR activates an alarm. The options are: <b>Electrical Trip</b> <b>None</b> <b>Shutdown</b> <b>Warning</b>
Arming	Select when the <i>AVR Fault</i> is monitored.  Options are as follows: <b>Always:</b> The alarm is active at any time the CAN Link is lost <b>From Safety On:</b> Active only after the <i>Safety On</i> delay timer <b>From Starting:</b> Active only after the <i>Crank Relay</i> is energised
Activation Delay	The time delay for the module to wait before activating <i>AVR Fault</i> alarm when detected.

**AVR**



**NOTE:** Ensure the generator's AVR has a wide enough range of adjustment to cater for nominal voltage adjustment whilst not affecting normal voltage synchronising or kvar load sharing functionality.

Parameter	Description
Allow Live Nominal Voltage Adjust	<input type="checkbox"/> = Adjustment of nominal voltage is disabled. <input checked="" type="checkbox"/> = The nominal voltage is adjusted through the running editor on the module display.

### 3.18.3 RESET ELECTRICAL TRIP

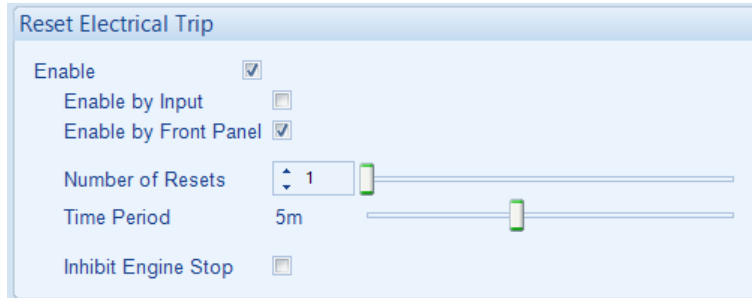
This feature is provided to assist the system designer in meeting specifications requirements to ensure the generator (if running) can take load again after the *Electrical Trip* alarm has been reset. Depending upon configuration, the generator may go into a cooling run or be inhibited from stopping after the *Electrical Trip* alarm activates.



Parameter	Description
Enable	<p><b>NOTE:</b> Writing a configuration to the controller that has <i>Reset Electrical Trip</i> enabled, results in a warning message appearing on the PC screen for the user to acknowledge before the controller's configuration is changed. This prevents inadvertent activation of the feature.</p> <p><input type="checkbox"/> = If an Electrical Trip alarm is reset, the generator must continue to cooldown before it becomes available again.  <input checked="" type="checkbox"/> = If an Electrical Trip alarm is reset, the generator is placed back on load if requested.</p>
Enable by Input	<p><b>NOTE:</b> Only possible to enable if an input is configured to <i>Reset Electrical Trip</i>.</p> <p><input type="checkbox"/> = <i>Reset Electrical Trip</i> only by pressing the <b>Close Generator</b>  button (if enabled).  <input checked="" type="checkbox"/> = <i>Reset Electrical Trip</i> by an input configured for <i>Reset Electrical Trip</i> or by pressing the <b>Close Generator</b>  button (if enabled).</p>
Enable by Front Panel	<p><input type="checkbox"/> = <i>Reset Electrical Trip</i> only by activating an input configured for <i>Reset Electrical Trip</i> (if enabled).  <input checked="" type="checkbox"/> = <i>Reset Electrical Trip</i> by pressing the <b>Close Generator</b>  button or activating an input configured for <i>Reset Electrical Trip</i> (if enabled).</p>
Number of Resets	The number of times any electrical trips are reset whilst the generator is running to enable it to go back on load. The counter goes to zero upon the generator stopping.
Time Period	The time interval for the <i>Number of Resets</i> . If the <i>Number of Resets</i> is reached within configured <i>Time Period</i> , no more resets can occur until the generator has stopped.
Inhibit Engine Stop	<p><b>NOTE:</b> Writing a configuration to the controller that has <i>Inhibit Engine Stop</i> enabled, results in a warning message appearing on the PC screen for the user to acknowledge before the controller's configuration is changed. This prevents inadvertent activation of the feature.</p> <p><input type="checkbox"/> = When an Electrical Trip alarm activates, the generator's load switch opens, and the generator goes into a cooling run before shutting down.  <input checked="" type="checkbox"/> = When an Electrical Trip alarm activates, the generator's load switch opens, and the generator continues to run with the <i>Electrical Trip Stop Inhibited Warning</i> alarm active.</p>

### 3.18.4 PLC

**NOTE:** For further details and instructions on the *PLC Editor*, refer to DSE Publication: *057-314 Advanced PLC Software Manual* which is found on our website: [www.deepseaelectronics.com](http://www.deepseaelectronics.com)

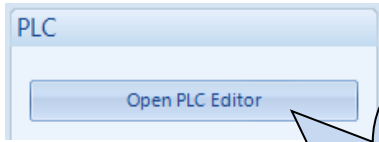

Click to open the *PLC Editor*, then the *PLC Editor* opens as shown below.

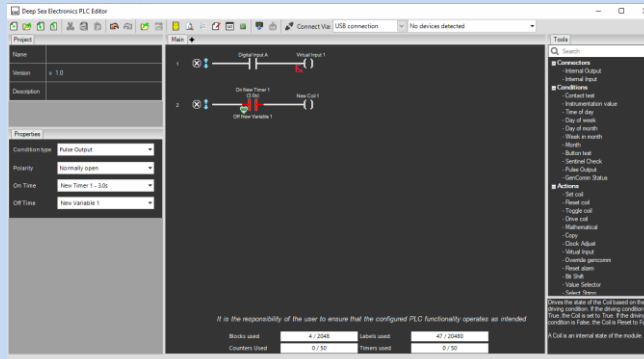

### 3.18.5 CONFIGURABLE GENCOMM PAGES 166 TO 169

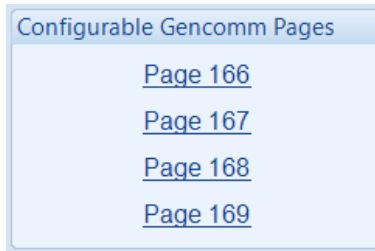

For advanced Modbus users of the controller, configurable GenComm pages are available. The intention is to allow the user to create personal collections of data in subsequent registers to minimise the number of Modbus reads required by the client and hence speed up data collection.

All configurable GenComm registers are 32-bit unsigned format.

Gencomm Page 166							
Register	Value	Register	Value	Register	Value	Register	Value
0-1	<Not Used>	64-65	<Not Used>	128-129	<Not Used>	192-193	<Not Used>
2-3	<Not Used>	66-67	<Not Used>	130-131	<Not Used>	194-195	<Not Used>
4-5	<Not Used>	68-69	<Not Used>	132-133	<Not Used>	196-197	<Not Used>
6-7	<Not Used>	70-71	<Not Used>	134-135	<Not Used>	198-199	<Not Used>
8-9	<Not Used>	72-73	<Not Used>	136-137	<Not Used>	200-201	<Not Used>
10-11	<Not Used>	74-75	<Not Used>	138-139	<Not Used>	202-203	<Not Used>
12-13	<Not Used>	76-77	<Not Used>	140-141	<Not Used>	204-205	<Not Used>
14-15	<Not Used>	78-79	<Not Used>	142-143	<Not Used>	206-207	<Not Used>
16-17	<Not Used>	80-81	<Not Used>	144-145	<Not Used>	208-209	<Not Used>
18-19	<Not Used>	82-83	<Not Used>	146-147	<Not Used>	210-211	<Not Used>
20-21	<Not Used>	84-85	<Not Used>	148-149	<Not Used>	212-213	<Not Used>
22-23	<Not Used>	86-87	<Not Used>	150-151	<Not Used>	214-215	<Not Used>
24-25	<Not Used>	88-89	<Not Used>	152-153	<Not Used>	216-217	<Not Used>
26-27	<Not Used>	90-91	<Not Used>	154-155	<Not Used>	218-219	<Not Used>
28-29	<Not Used>	92-93	<Not Used>	156-157	<Not Used>	220-221	<Not Used>
30-31	<Not Used>	94-95	<Not Used>	158-159	<Not Used>	222-223	<Not Used>
32-33	<Not Used>	96-97	<Not Used>	160-161	<Not Used>	224-225	<Not Used>
34-35	<Not Used>	98-99	<Not Used>	162-163	<Not Used>	226-227	<Not Used>
36-37	<Not Used>	100-101	<Not Used>	164-165	<Not Used>	228-229	<Not Used>
38-39	<Not Used>	102-103	<Not Used>	166-167	<Not Used>	230-231	<Not Used>
40-41	<Not Used>	104-105	<Not Used>	168-169	<Not Used>	232-233	<Not Used>
42-43	<Not Used>	106-107	<Not Used>	170-171	<Not Used>	234-235	<Not Used>
44-45	<Not Used>	108-109	<Not Used>	172-173	<Not Used>	236-237	<Not Used>
46-47	<Not Used>	110-111	<Not Used>	174-175	<Not Used>	238-239	<Not Used>

The configurable Modbus pages are:

Page	Hex Address	Decimal Address
166	A600	42496
167	A700	42752
168	A800	43008
169	A900	43264

**Example of GenComm Page Configuration:**

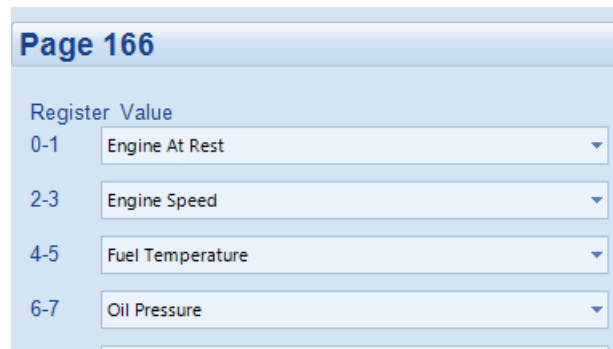

The register address is obtained from the formula:

$\text{register\_address} = \text{page\_number} * 256 + \text{register\_offset}$ .

To read the *Engine Speed* from the above register, the Modbus client device needs to read the data in two registers and then combine the data from the Most Significant Bit and the Least Significant Bit.

MSB address in Decimal =  $(166 * 256) + 2 = 42498$

LSB address in Decimal =  $(166 * 256) + 3 = 42499$

## 4 SCADA

SCADA stands for Supervisory Control And Data Acquisition and is provided both as a service tool and as a means of monitoring and controlling the generator set.

As a service tool, the SCADA pages are to check the operation of the controller's inputs and outputs as well as checking the generators operating parameters.

Click to open the connection to the module. If no module is connected, the SCADA opens to show the screens for the type of module currently open in the configuration.

When connection is made...

Click to close the connection to the module

The Module's firmware revision number

The SCADA page is subdivided into smaller sections. Select the required section with the mouse.

**NOTE:** The SCADA sections appear depending on how the module is configured.

### Example

#### Single Set

Mains is available in Single Set mode

#### Multi Set

Bus is available in Multi Set mode

## 4.1 GENERATOR IDENTITY

This section displays the module's configuration settings for *Site ID* and *Genset ID*. For further details on how to configure these items, refer to the section entitled *Communications Options* elsewhere in this document.



## 4.2 MIMIC

This section provides a mimic of the module's fascia and allows the operator to change the control mode of the module.



**Commissioning**

Commissioning

Show Overview Instrumentation

Parameter	Description
Show Overview Instrumentation	<input type="checkbox"/> = Overview instrumentation is disabled. <input checked="" type="checkbox"/> = Overview instrumentation is displayed.

**Overview Instrumentation**

<p><b>Generator</b></p> <p><u>Frequency</u> 0.00 Hz</p> <p><u>Phase To Neutral Voltages</u></p> <table border="1"> <tr> <td>L1 - N</td> <td>L2 - N</td> <td>L3 - N</td> </tr> <tr> <td>0.0 V</td> <td>0.0 V</td> <td>0.0 V</td> </tr> </table> <p><u>Phase To Phase Voltages</u></p> <table border="1"> <tr> <td>L1 - L2</td> <td>L2 - L3</td> <td>L3 - L1</td> </tr> <tr> <td>0.0 V</td> <td>0.0 V</td> <td>0.0 V</td> </tr> </table> <p><u>Current</u></p> <table border="1"> <tr> <td>L1</td> <td>L2</td> <td>L3</td> </tr> <tr> <td>0 A</td> <td>0 A</td> <td>0 A</td> </tr> </table> <p><u>Earth Current</u> 0 A</p> <p><u>Watts</u></p> <table border="1"> <tr> <td>L1</td> <td>L2</td> <td>L3</td> <td>Total</td> </tr> <tr> <td>0.00 kW</td> <td>0.00 kW</td> <td>0.00 kW</td> <td>0.00 kW</td> </tr> <tr> <td>0.0 %</td> <td>0.0 %</td> <td>0.0 %</td> <td>0.0 %</td> </tr> </table> <p><u>VA</u></p> <table border="1"> <tr> <td>L1</td> <td>L2</td> <td>L3</td> <td>Total</td> </tr> <tr> <td>0.0 kVA</td> <td>0.0 kVA</td> <td>0.0 kVA</td> <td>0.0 kVA</td> </tr> </table> <p><u>VAr</u></p> <table border="1"> <tr> <td>L1</td> <td>L2</td> <td>L3</td> <td>Total</td> </tr> <tr> <td>0.0 kVAr</td> <td>0.0 kVAr</td> <td>0.0 kVAr</td> <td>0.0 kVAr</td> </tr> </table> <p><u>Power Factor</u></p> <table border="1"> <tr> <td>L1</td> <td>L2</td> <td>L3</td> <td>Average</td> </tr> <tr> <td>0.00</td> <td>0.00</td> <td>0.00</td> <td>---</td> </tr> </table>	L1 - N	L2 - N	L3 - N	0.0 V	0.0 V	0.0 V	L1 - L2	L2 - L3	L3 - L1	0.0 V	0.0 V	0.0 V	L1	L2	L3	0 A	0 A	0 A	L1	L2	L3	Total	0.00 kW	0.00 kW	0.00 kW	0.00 kW	0.0 %	0.0 %	0.0 %	0.0 %	L1	L2	L3	Total	0.0 kVA	0.0 kVA	0.0 kVA	0.0 kVA	L1	L2	L3	Total	0.0 kVAr	0.0 kVAr	0.0 kVAr	0.0 kVAr	L1	L2	L3	Average	0.00	0.00	0.00	---	<p><b>Bus</b></p> <p><u>Frequency</u></p> <p><u>Phase To Neutral Voltages</u></p> <table border="1"> <tr> <td>L1 - N</td> <td>L2 - N</td> <td>L3 - N</td> </tr> <tr> <td></td> <td></td> <td></td> </tr> </table> <p><u>Phase To Phase Voltages</u></p> <table border="1"> <tr> <td>L1 - L2</td> <td>L2 - L3</td> <td>L3 - L1</td> </tr> <tr> <td></td> <td></td> <td></td> </tr> </table> <p><u>Fault Ride Through</u> 0 Events</p>	L1 - N	L2 - N	L3 - N				L1 - L2	L2 - L3	L3 - L1			
L1 - N	L2 - N	L3 - N																																																																	
0.0 V	0.0 V	0.0 V																																																																	
L1 - L2	L2 - L3	L3 - L1																																																																	
0.0 V	0.0 V	0.0 V																																																																	
L1	L2	L3																																																																	
0 A	0 A	0 A																																																																	
L1	L2	L3	Total																																																																
0.00 kW	0.00 kW	0.00 kW	0.00 kW																																																																
0.0 %	0.0 %	0.0 %	0.0 %																																																																
L1	L2	L3	Total																																																																
0.0 kVA	0.0 kVA	0.0 kVA	0.0 kVA																																																																
L1	L2	L3	Total																																																																
0.0 kVAr	0.0 kVAr	0.0 kVAr	0.0 kVAr																																																																
L1	L2	L3	Average																																																																
0.00	0.00	0.00	---																																																																
L1 - N	L2 - N	L3 - N																																																																	
L1 - L2	L2 - L3	L3 - L1																																																																	
<p><b>VDE</b></p> <p><u>Mains Stability Monitoring Timer</u> Timer Restart Count Timer</p> <p><u>VDE Frequency-Power</u></p> <table border="1"> <tr> <td>Rolling Average Frequency</td> <td>Return Timer</td> <td>Power</td> </tr> <tr> <td>0.00 Hz</td> <td>0.0s</td> <td>120.0 %</td> </tr> </table> <p><u>VDE Voltage-Reactive Power</u></p> <table border="1"> <tr> <td>Rolling Average U/Uc</td> <td>Rolling Average U/Uc Hysteresis</td> <td>Q/Pblnst</td> </tr> <tr> <td>0.000 PU</td> <td>0.000 PU</td> <td>-0.330</td> </tr> </table> <p><u>VDE Power-Reactive Power</u></p> <table border="1"> <tr> <td>Rolling Average P/Pblnst</td> <td>Q/Pblnst</td> </tr> <tr> <td></td> <td></td> </tr> </table> <p><u>VDE Reactive Power Limited</u></p> <table border="1"> <tr> <td>Rolling Average U/Uc</td> <td>Q/Pblnst</td> </tr> <tr> <td></td> <td></td> </tr> </table>	Rolling Average Frequency	Return Timer	Power	0.00 Hz	0.0s	120.0 %	Rolling Average U/Uc	Rolling Average U/Uc Hysteresis	Q/Pblnst	0.000 PU	0.000 PU	-0.330	Rolling Average P/Pblnst	Q/Pblnst			Rolling Average U/Uc	Q/Pblnst			<p><b>Engine</b></p> <p><u>Speed</u> 0 RPM</p> <p><u>Oil Pressure</u> 3.99Bar, 57.9 PSI, 399 kPa</p> <p><u>Coolant Temperature</u> 63 °C, 145 °F</p> <p><b>Sync</b></p> <p><u>Governor Analogue</u> 0.0 %</p> <p><u>AVR Analog</u> 0.0 %</p> <p><u>kW Target</u> 0.0 %</p> <p><u>kVAr Target</u> 0.0 %</p>																																														
Rolling Average Frequency	Return Timer	Power																																																																	
0.00 Hz	0.0s	120.0 %																																																																	
Rolling Average U/Uc	Rolling Average U/Uc Hysteresis	Q/Pblnst																																																																	
0.000 PU	0.000 PU	-0.330																																																																	
Rolling Average P/Pblnst	Q/Pblnst																																																																		
Rolling Average U/Uc	Q/Pblnst																																																																		

### 4.3 DIGITAL INPUTS

This section displays the status of the module's digital inputs and their configured functions. For further details on how to configure these items, refer to the section entitled *Digital Inputs* elsewhere in this document.

The screenshot shows a 'Digital Inputs' panel with the following data:

Input Label	Active	Open / Closed
A Remote Start On Load	●	⏏
B Remote Start On Load Demand (Multi Set)	●	⏏
C Generator Closed Auxiliary	●	⏏
D Mains Closed Auxiliary (Single Set)	●	⏏
E Digital Input E	●	⏏
F Digital Input F	●	⏏
G Digital Input G	●	⏏
H Duty Select (Multi Set)	●	⏏
I External Panel Lock	●	⏏
Emergency Stop		⏏

Callout 1 (pointing to the 'Active' column): Shows if the input channel is active or not. This input is open and not active. The input is configured to be *Close to Activate*

Callout 2 (pointing to the 'Open / Closed' column): State of the input (open or closed to battery negative)

Callout 3 (pointing to the 'Emergency Stop' input): State of the *Emergency Stop* input (open or closed to battery positive). This input **MUST** be closed to battery positive for *normal* operation. If the input is open, the generator is stopped if it is already running and not allowed to start.

## 4.4 VIRTUAL INPUTS

This section displays and controls the status of the module's *Virtual Input Control Sources*. Any of the module's outputs, expansion outputs, LED indicators, expansion LEDs indicators or PLC Flag Tests are to be configured to *Remote Control 1 to 10*. They are provided to enable control using the SCADA section of the DSE Configuration Suite or by third party PLC or Building Management Systems (for example) using the Modbus protocol. For further details on how to configure these items, refer to the section entitled *Digital Outputs* elsewhere in this document.

The screenshot shows a software interface titled "Virtual Inputs" with a sub-section "Virtual Input Control Sources". It contains a table with 12 rows, each representing a virtual input. The columns are "Control", "Open / Closed", and "Active".

Control	Open / Closed	Active
1 8610	<input checked="" type="checkbox"/>	<input checked="" type="checkbox"/>
2 8620	<input checked="" type="checkbox"/>	<input checked="" type="checkbox"/>
3 Virtual Input 3	<input type="checkbox"/>	<input checked="" type="checkbox"/>
4 Virtual Input 4	<input type="checkbox"/>	<input checked="" type="checkbox"/>
5 Virtual Input 5	<input type="checkbox"/>	<input checked="" type="checkbox"/>
6 Virtual Input 6	<input type="checkbox"/>	<input checked="" type="checkbox"/>
7 Virtual Input 7	<input type="checkbox"/>	<input checked="" type="checkbox"/>
8 Virtual Input 8	<input type="checkbox"/>	<input checked="" type="checkbox"/>
9 Virtual Input 9	<input type="checkbox"/>	<input checked="" type="checkbox"/>
10 Virtual Input 10	<input type="checkbox"/>	<input checked="" type="checkbox"/>
11 Virtual Input 11	<input type="checkbox"/>	<input type="checkbox"/>
12 Virtual Input 12	<input type="checkbox"/>	<input type="checkbox"/>

Annotations in the image:

- A callout bubble points to the "Active" column, stating: "For a Gencomm activation in Scada, the input is triggered when the Scada button is released." (Note: The bubble in the image incorrectly says "button" instead of "release").
- A callout bubble points to a green dot in the "Active" column, stating: "State of the Virtual Input (on or off)".
- A callout bubble points to a checkbox in the "Control" column, stating: "☐ = Virtual Input function name is de-activated. ☑ = Virtual Input function name is activated." (Note: The bubble in the image incorrectly says "name" instead of "checkbox").

## 4.5 DIGITAL OUTPUTS

This section displays the status of the module's digital outputs and their configured functions. For further details on how to configure these items, refer to the section entitled *Digital Outputs* elsewhere in this document.

Relay Outputs (Supplied From Emergency Stop Input)			
		Active	Open / Closed
A	Fuel Relay	<input checked="" type="checkbox"/>	<input type="checkbox"/> <input checked="" type="checkbox"/>
B	Start Relay	<input checked="" type="checkbox"/>	<input type="checkbox"/> <input checked="" type="checkbox"/>

Relay Outputs (Volts Free)			
		Active	Open / Closed
C (N/C)	Not Used	<input checked="" type="checkbox"/>	<input type="checkbox"/> <input checked="" type="checkbox"/>
D	Close Gen Output	<input checked="" type="checkbox"/>	<input type="checkbox"/> <input checked="" type="checkbox"/>

Digital Outputs (DC Supply Out)			
		Active	Open / Closed
E	Preheat During Preheat Timer	<input checked="" type="checkbox"/>	<input type="checkbox"/> <input checked="" type="checkbox"/>
F	Common Alarm	<input checked="" type="checkbox"/>	<input type="checkbox"/> <input checked="" type="checkbox"/>
G	Audible Alarm	<input checked="" type="checkbox"/>	<input type="checkbox"/> <input checked="" type="checkbox"/>
H	System In Auto Mode	<input checked="" type="checkbox"/>	<input type="checkbox"/> <input checked="" type="checkbox"/>
I	Fuel Pump Control	<input checked="" type="checkbox"/>	<input type="checkbox"/> <input checked="" type="checkbox"/>
J	Fuel Level Low Alarm	<input checked="" type="checkbox"/>	<input type="checkbox"/> <input checked="" type="checkbox"/>
K	Not Used	<input checked="" type="checkbox"/>	<input type="checkbox"/> <input checked="" type="checkbox"/>
L	Not Used	<input checked="" type="checkbox"/>	<input type="checkbox"/> <input checked="" type="checkbox"/>

State of the output (open or closed)

Shows if the output channel is active or not. This output is open and is not active.

## 4.6 VIRTUAL LEDS

This section displays the status of the module's *Virtual LEDs* which are shown on the modules screen (10 available, see the section entitled *Virtual LEDs* in the *Outputs* section elsewhere in this document) and the functions they are configured for. They are provided to show status and appear only in the SCADA section of the DSE Configuration Suite or read by third party PLC or Building Management Systems (for example) using the Modbus protocol. For further details on how to configure these items, refer to the section entitled *Digital Outputs* elsewhere in this document.

The screenshot displays two panels for LED status. The top panel, titled 'LED 1-10 Status', lists the following functions and their status:

Function	Status	Active
System in Auto Mode	Not Used	●
LED 2	Not Used	●
LED 3	Not Used	●
LED 4	Not Used	●
Common Alarm	Not Used	●
Common Shutdown	Not Used	●
LED 7	Not Used	●
LED 8	Not Used	●
LED 9	Not Used	●
LED 10	Not Used	●

The bottom panel, titled 'LED 11-20 Status', lists the following functions and their status:

Function	Status	Active
LED 11	Not Used	●
LED 12	Not Used	●
LED 13	Not Used	●
LED 14	Not Used	●
LED 15	Not Used	●
LED 16	Not Used	●
LED 17	Not Used	●
LED 18	Not Used	●
LED 19	Not Used	●
LED 20	Not Used	●

Callout 1 (left): Shows what the Virtual LED is configured to indicate.

Callout 2 (right): State of the LED (on or off)

## 4.7 BUS (MULTI SET)

This section displays the module's measurement of the *Bus*.

Bus		
Frequency		
0.00 Hz		
Phase Rotation		
Indeterminate		
Phase To Neutral Voltages		
L1 - N 0.0 V	L2 - N 0.0 V	L3 - N 0.0 V
Phase To Phase Voltages		
L1 - L2 0.0 V	L2 - L3 0.0 V	L3 - L1 0.0 V
Fault Ride Through		
0 Events		

## 4.8 MAINS (SINGLE SET)

The *Mains* section is subdivided into smaller sections. Select the required section with the mouse.

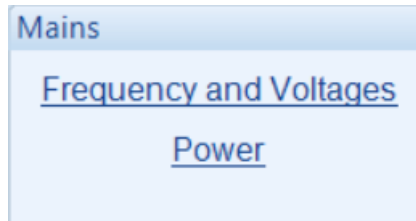

### 4.8.1 FREQUENCY & VOLTAGES

This section displays the module's measurement of the *Mains* frequency, phase voltages, current and phase rotation.

Mains		
Frequency		
0.00 Hz		
Phase To Neutral Voltages		
L1 - N 0.0 V	L2 - N 0.0 V	L3 - N 0.0 V
Phase To Phase Voltages		
L1 - L2 0.0 V	L2 - L3 0.0 V	L3 - L1 0.0 V
Mains Current		
L1 0 A		
Phase Rotation		
Indeterminate		

## 4.8.2 POWER

This section displays the module's measurement of the *Power* the Mains is supplying.

Power	
Watts	
L1 0.00 kW	Total 0.00 kW 0.0 %
VA	
L1 0.0 kVA	Total 0.0 kVA
VAr	
L1 0.0 kVAr	Total 0.0 kVAr
Power factor	
L1 0.00	Average 0.00

## 4.9 GENERATOR

**NOTE:** The *Generator* page will display different sections based on the selected mode. If *Multi Set and Single Set* mode is chosen, the *Single Set* screen will be displayed.

The *Generator* section is subdivided into smaller sections.

Select the required section with the mouse.

Multi Set

Generator

Frequency, Voltages and Current

Power

AMSC Link

Governor / AVR Interface

Sync

Load Levels

Droop

De-Rate

Single Set

Generator

Frequency, Voltages and Current

Power

Governor / AVR Interface

Sync

Load Control

Load Levels

De-Rate

### 4.9.1 FREQUENCY, VOLTAGES AND CURRENT

This section displays the module's measurement of the *Generator* frequency, voltage, and current supply.

Frequency		
50.01 Hz		
Phase To Neutral Voltages		
L1 - N 240.1 V	L2 - N 240.1 V	L3 - N 240.2 V
Phase To Phase Voltages		
L1 - L2 415.9 V	L2 - L3 415.0 V	L3 - L1 415.4 V
Current		
L1 36.0 A	L2 36.0 A	L3 36.0 A
Earth Current		
0.0 A		
Phase Rotation		
L1-L2-L3		

### 4.9.2 POWER

This section displays the module's measurement of the *Power* the *Generator* is supplying.

Watts			
L1	L2	L3	Total
8.62 kW	8.67 kW	8.62 kW	25.91 kW
9.9 %	10.0 %	9.9 %	9.9 %

VA			
L1	L2	L3	Total
8.6 kVA	8.7 kVA	8.7 kVA	26.0 kVA

VAr			
L1	L2	L3	Total
0.1 kVAr	0.0 kVAr	0.1 kVAr	0.2 kVAr

Power factor			
L1	L2	L3	Average
0.99	1.00	1.00	0.99

Accumulated Power			
-kWh	kWh	kVAh	kVArh
	69036.7 kWh	75913.8 kVAh	8096.8 kVArh

### 4.9.3 AMSC LINK (MULTI SET)

This section displays the status of the AMSC Link.

**AMSC Link**

**Bus**

Sets On The Bus	1	
Sets On Load	0	
Mains Controllers On The Bus	0	Shows the status of the Bus and configuration of modules.
Segment Number	1	
Bus Ties On The Bus	0	
Group Controllers On The Bus	0	
Group Controllers On Load	0	
Is In A Group	<input checked="" type="checkbox"/>	

**GenSet**

AMSC ID	1	▲▼ 1	<input type="button" value="Set"/>	Allows priority number to be configured.
Priority	1	▲▼ 1	<input type="button" value="Set"/>	

**Commissioning Screen**

Enable

Enables commissioning screen on the module.

**4.9.3.1.1 ADJUSTING GAIN (P), STABILITY (I) AND DERIVATIVE (D)**

**Initial Setup**

In most cases the DSE factory settings of 20% for *Gain (P)*, *Stability (I)* and 0 % for *Derivative (D)* are suitable for most systems. This is because the DSE module's control is limited by the *Gain (P)*, *Stability (I)* and *Derivative (D)* settings of the engine's governor / alternator's AVR. Before adjusting the DSE module's settings, adjust the *Gain (P)*, *Stability (I)* and *Derivative (D)* settings of the engine's governor / alternator's AVR in accordance with the manufacturer's recommendations.

**Calibration**

If the load sharing response of the system is not satisfactory after adjusting the *Gain (P)*, *Stability (I)* and *Derivative (D)* settings of the engine's governor / alternator's AVR, then start to adjust the DSE's settings by:

1. Starting with the *Gain (P)*, *Stability (I)* at 5 % and *Derivative (D)* at 0%. Place the generators in parallel with no load.
2. Gradually increase the *Gain (P)* setting until the generator power production becomes unstable. Very slowly decrease the *Gain (P)* setting, until the power production stabilises. Reduce the setting further by approximately 10 %.
3. Gradually increase the *Stability (I)* setting until the generator power production becomes unstable. Very slowly decrease the *Stability (I)* setting, until the power production stabilises.
4. Apply and remove load to the generators using a load bank to test response and ensure no oscillation of power between generators. If a load bank is not available repeat the synchronising process several times to see the effect of the changes. Also attempt to 'knock' the governor actuator or change the 'slip frequency' setting to disturb the engine speed and force the controller into making further changes.
5. To improve the load change repose, increase the *Derivative (D)* setting to decrease the overshoot and settling time.

The affect the *Gain (P)*, *Stability (I)* and *Derivative (D)* settings have on the response of a load step being applied to the generator are shown below.

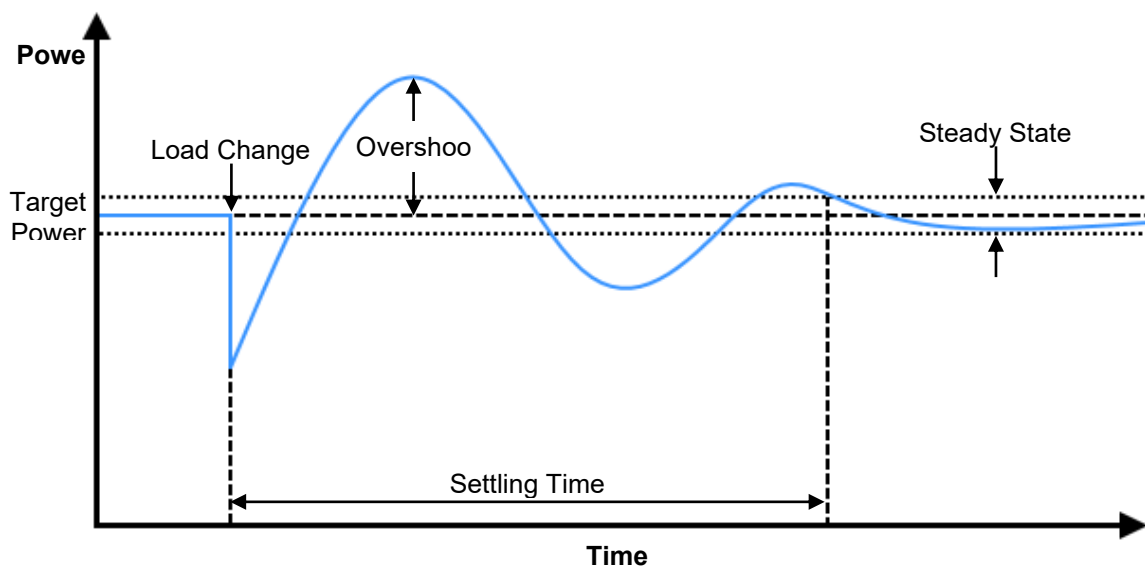

PID Adjustment	Overshoot	Settling Time	Steady State Error
Increase Gain (P)	Increases	Minimal Effect	Decreases
Increase Stability (I)	Increases	Increases	Eliminates
Increase Derivative (D)	Decrease	Decreases	No Effect

## Troubleshooting

 **NOTE: An over damped response results in a slower control process. An under damped response (overshooting the target) leads to an unstable control process. Either case leads to undesirable consequences such as overcurrent or reverse power, resulting in generator shutdown, and loss of supply to the load.**

If the load is oscillating quickly between the generators, it suggests that the setting for the *Gain (P)* on the generator(s) is too high or too low. A slow rolling oscillation usually indicates that the *Stability (I)* is too high or too low. These oscillations are caused by incorrect settings on the engine's governor / alternator's AVR and/or the DSE module.

It is possible for the load sharing stability to change as different generators are go in and out of parallel with one another. Ensure that the *Gain (P)*, *Stability (I)* and *Derivative (D)* are calibrated to give a stable condition when all generators are running in parallel.

#### 4.9.4 GOVERNOR / AVR INTERFACE

**NOTE:** These settings are not saved within the module's configuration file. They are stored in a different memory area and not transferred with the configuration file. The *Backup Module* feature transfers both the configuration file AND the settings of the Multi-set, Governor / AVR interface and Sync page.

This section allows the user to calibrate the SW1 (Switch 1) and SW2 (Switch 2) settings for the *Analogue Governor Output* and *Analogue AVR Output* which the DSE module uses to control synchronising and load sharing.

As the input requirements of governors and AVRs vary from manufacturer to manufacturer, and even from model to model, the DSE module is configurable to allow connection to these devices. For information regarding typical wiring diagrams and suggested SW1 / SW2 settings for common governors and AVRs, refer to DSE publication: **057-046 DSE Guide to Synchronising and Load Sharing (Part 2)** which is found on the DSE website: [www.deepseaelectronics.com](http://www.deepseaelectronics.com).

The screenshot displays the following data:

Governor	
Centre (SW1)	4.9
Range (SW2)	6.8

Speed And Frequency	
Engine Speed	1499 RPM
Generator Frequency	49.98 Hz
Governor Analogue	3.0 %
AVR Analog	-1.1 %

**Callout:** Governor and AVR Analogue percentage of drive.

AVR	
Centre (SW1)	0.0
Range (SW2)	7.0

Phase To Neutral Voltages		
L1 - N	L2 - N	L3 - N
239.9 V	240.3 V	239.8 V

Phase To Phase Voltages		
L1 - L2	L2 - L3	L3 - L1
416.8 V	416.8 V	415.3 V

##### 4.9.4.1 SW1

SW1 is also known as *Centre*. SW1 sets the voltage produced by the DSE module's *Analogue Governor / AVR Outputs* for 'nominal' running condition. For example, SW1 = 5 for the *Analogue Governor Output*, means that the *Analogue Governor Output* is 2.5 V<sub>DC</sub> when the generator is required to run at its nominal speed.

##### 4.9.4.2 SW2

SW2 is also known as *Range*. SW2 sets the range of adjustment around the SW1 (*Centre*) voltage to adjust engine speed or generator voltage away from nominal conditions. For example, SW2 = 3 for the *Analogue Governor Output*, means that the *Analogue Governor Output* is made to change by  $\pm 2$  V<sub>DC</sub> around the SW1 (*Centre*) voltage to make the engine run at lower/higher speed to synchronise or to increase/decrease kW for load sharing.

#### 4.9.4.3 VOLTAGE SETTINGS

The *Analogue Governor Output* and *Analogue AVR Output* are both isolated from ground and battery negative, allowing compatibility with devices with inputs that are not referenced to ground or battery negative. The table below specifies the relationship between the SW1 / SW2 setting and the voltage set point.

SW1 Setting	SW2 Setting	Centre Voltage of Governor/AVR	Range Voltage	Maximum Voltage Range of Governor/AVR Analogue Output
-19	1	-9.5	± 0.5	-10 VDC to -9 VDC
-18	2	-9.0	± 1.0	-10 VDC to -8 VDC
-17	3	-8.5	± 1.5	-10 VDC to -7 VDC
-16	4	-8.0	± 2.0	-10 VDC to -6 VDC
-15	5	-7.5	± 2.5	-10 VDC to -5 VDC
-14	6	-7.0	± 3.0	-10 VDC to -4 VDC
-13	7	-6.5	± 3.5	-10 VDC to -3 VDC
-12	8	-6.0	± 4.0	-10 VDC to -2 VDC
-11	9	-5.5	± 4.5	-10 VDC to -1 VDC
-10	10	-5.0	± 5.0	-10 VDC to 0 VDC
-9	11	-4.5	± 5.5	-10 VDC to 1 VDC
-8	12	-4.0	± 6.0	-10 VDC to 2 VDC
-7	13	-3.5	± 6.5	-10 VDC to 3 VDC
-6	14	-3.0	± 7.0	-10 VDC to 4 VDC
-5	15	-2.5	± 7.5	-10 VDC to 5 VDC
-4	16	-2.0	± 8.0	-10 VDC to 6 VDC
-3	17	-1.5	± 8.5	-10 VDC to 7 VDC
-2	18	-1.0	± 9.0	-10 VDC to 8 VDC
-1	19	-0.5	± 9.5	-10 VDC to 9 VDC
0	20	0.0	± 10	-10 VDC to 10 VDC
1	19	0.5	± 9.5	10 VDC to -9 VDC
2	18	1.0	± 9.0	10 VDC to -8 VDC
3	17	1.5	± 8.5	10 VDC to -7 VDC
4	16	2.0	± 8.0	10 VDC to -6 VDC
5	15	2.5	± 7.5	10 VDC to -5 VDC
6	14	3.0	± 7.0	10 VDC to -4 VDC
7	13	3.5	± 6.5	10 VDC to -3 VDC
8	12	4.0	± 6.0	10 VDC to -2 VDC
9	11	4.5	± 5.5	10 VDC to -1 VDC
10	10	5.0	± 5.0	10 VDC to 0 VDC
11	9	5.5	± 4.5	10 VDC to 1 VDC
12	8	6.0	± 4.0	10 VDC to 2 VDC
13	7	6.5	± 3.5	10 VDC to 3 VDC
14	6	7.0	± 3.0	10 VDC to 4 VDC
15	5	7.5	± 2.5	10 VDC to 5 VDC
16	4	8.0	± 2.0	10 VDC to 6 VDC
17	3	8.5	± 1.5	10 VDC to 7 VDC
18	2	9.0	± 1.0	10 VDC to 8 VDC
19	1	9.5	± 0.5	10 VDC to 9 VDC

**4.9.4.4 SUMMARY**

Consider the settings for the *Analogue Governor / AVR Output* as  $SW1 \pm SW2$

Example 1

In this example the *Analogue Governor Output* is  $7 V_{DC} \pm 3V_{DC}$  (based upon the settings of  $SW1 = 14$  and  $SW2 = 6$ ), effectively giving a range of adjustment between  $4.0 V_{DC}$  to  $10.0 V_{DC}$ .

SW1 Setting	Maximum SW2 Setting	Centre Voltage of Governor/AVR Analogue Output	Maximum Voltage Range of Governor/AVR Analogue Output	Maximum Voltage Range of Analogue Output
14	6	7	10 VDC to 4 VDC	$\pm 3$

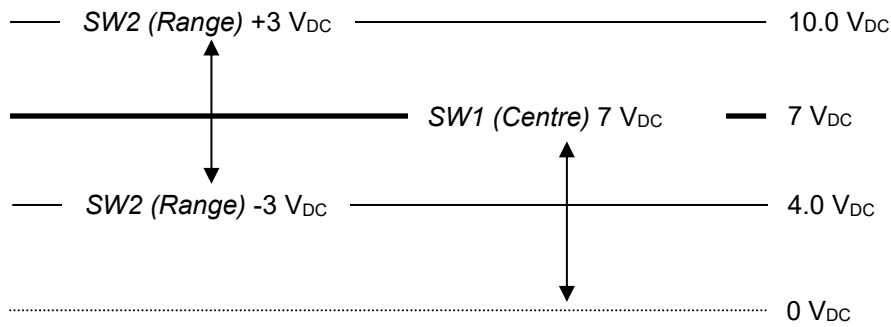

Example 2

In this example the *Analogue Governor Output* is  $0.5 V_{DC} \pm 9.5V_{DC}$  (based upon the settings of  $SW1 = 1$  and  $SW2 = 19$ ), effectively giving a range of adjustment between  $-9 V_{DC}$  to  $10.0 V_{DC}$ .

SW1 Setting	Maximum SW2 Setting	Centre Voltage of Governor/AVR Analogue Output	Maximum Voltage Range of Governor/AVR Analogue Output	Maximum Voltage Range of Analogue Output
1	19	0.5	10 VDC to -9 VDC	$\pm 9.5$

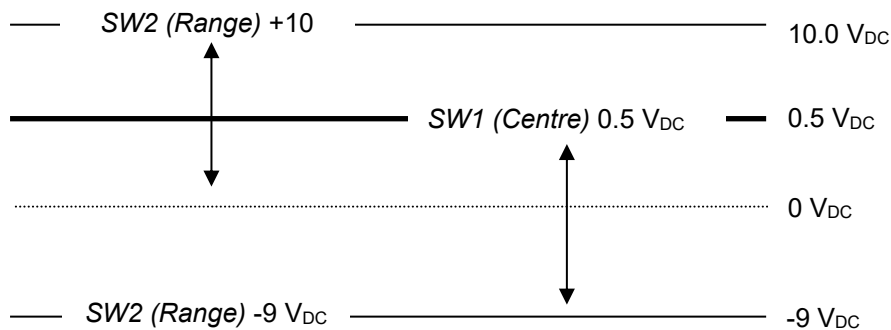

## 4.9.4.5 CURRENT SETTINGS

SW1 Setting	Maximum SW2 Setting	Centre Current of Governor/AVR Analogue Output	Maximum Current Range of Governor/AVR Analogue Output	Maximum Current Range of Analogue Output
1	1	1	0 mA to 2 mA	2
2	2	2	0 mA to 4 mA	4
3	3	3	0 mA to 6 mA	6
4	4	4	0 mA to 8 mA	8
5	5	5	0 mA to 10 mA	10
6	6	6	0 mA to 12 mA	12
7	7	7	0 mA to 14 mA	14
8	8	8	0 mA to 16 mA	16
9	9	9	0 mA to 18 mA	18
10	10	10	0 mA to 20 mA	20
11	9	11	2 mA to 20 mA	18
12	8	12	4 mA to 20 mA	16
13	7	13	6 mA to 20 mA	14
14	6	14	8 mA to 20 mA	12
15	5	15	10 mA to 20 mA	10
16	4	16	12 mA to 20 mA	8
17	3	17	14 mA to 20 mA	6
18	2	18	16 mA to 20 mA	4
19	1	19	18 mA to 20 mA	2

**Example:**

In this example the Analogue Governor Output is 12 mA  $\pm$  8 mA (based upon the settings of SW1 = 12 and SW2 = 8), effectively giving a range of adjustment between 4 mA to 20 mA.

SW1 Setting	Maximum SW2 Setting	Centre Current of Governor/AVR Analogue Output	Maximum Current Range of Governor/AVR Analogue Output	Maximum Current Range of Analogue Output
12	8	12 mA	4 mA to 20 mA	16 mA

### 4.9.5 SYNC

The *Sync* section is subdivided into smaller sections. Select the required section with the mouse.

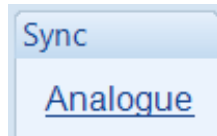

#### 4.9.5.1 ANALOGUE

##### Frequency Synchroniser

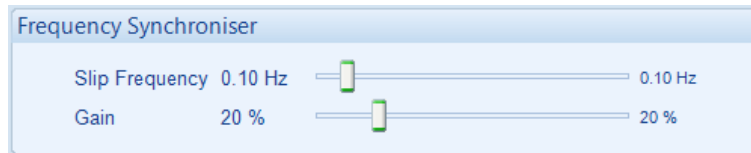

Parameter	Description
Slip Frequency	This is the frequency difference between the generator and the bus which the module adjusts to during synchronising. This is done to match the phase of the generator supply to bus supply. The phase of the supplies then drifts in and out of synchronism at a rate of $1/\text{Slip Frequency}$ times per second. e.g., with a <i>Slip Frequency</i> of 0.2 Hz, the supplies are in phase once every five seconds.
Gain	The setting for the gain of the control loop used for the frequency synchroniser. In general, a lower setting results in a slow frequency matching process. Having a high a setting may cause instability (hunting) if this occurs lower the gain setting.

##### Sync Locking

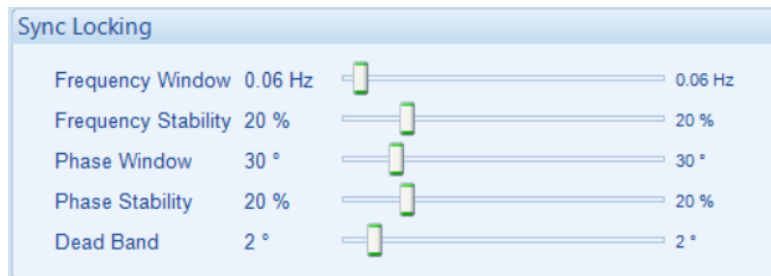

Parameter	Description
Frequency Window	The setting for adjusting the allowed frequency range.
Frequency Stability	The setting for adjusting the frequency which governs the amount of power produced.
Phase Window	The setting for adjusting the allowed phase shift.
Phase Stability	The setting to allow the amount of phase drift.
Dead Band	The setting for adjusting the total governor non-response zone.

**How to Setup Phase Locking**

- Ensure Slip Sync is functioning
- Ensure the frequency window is less than 0.1Hz
- Set the frequency stability gain the same as frequency synchroniser gain
- Adjust the phase stability to slowly bring the system into sync until it's within the phase window. If it overshoots, then reduce the gain and increase the dead band setting

**NOTE:** A wide phase window increases the time to achieve sync but allows more time for the set to settle before entering the sync window.

**Voltage Matcher**

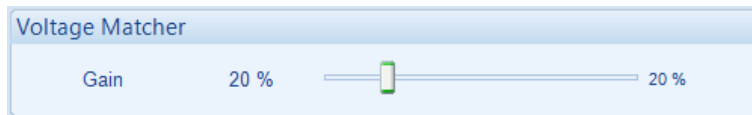

Parameter	Description
Gain	The setting for the gain of the control loop used for the voltage synchroniser. In general, a lower setting results in a slow frequency matching process. Having a high a setting may cause instability (hunting) if this occurs lower the gain setting.

**Load Share Mode**

For information regarding calibrating these settings, refer to the section entitled *Adjusting Gain (P), Stability (I) and Derivative (D)* elsewhere in this document.

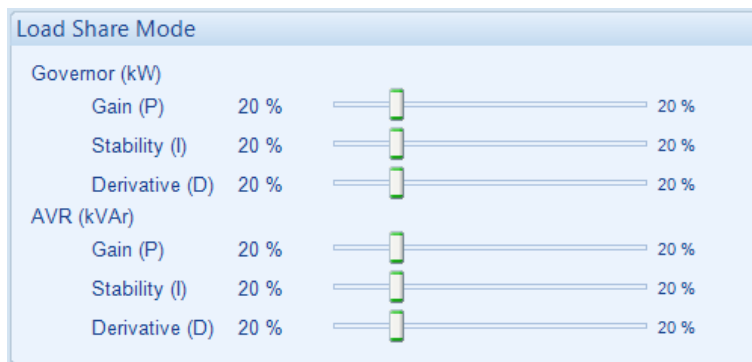

Parameter	Description
Governor (kW) Gain (P) Stability (I) Derivative (D)	The setting for the Gain (P), Stability (I) and Derivative (D) of the control loop used for the isochronous kW load sharing.
AVR (kvar) Gain (P) Stability (I) Derivative (D)	The setting for the Gain (P), Stability (I) and Derivative (D) of the control loop used for the kvar load sharing.

**Mains Parallel Mode**

**NOTE:** The *Mains Parallel Mode* PID settings only have effect when a digital input is configured for *Mains Parallel Mode* instructing the module to operate in fixed export mode with the utility supply. For more information on this application, refer to DSE Publication: *056-054 DSE8x10 in Fixed Export (Base Load)* which is found on our website: [www.deepseaelectronics.com](http://www.deepseaelectronics.com)

The user has the ability to configure different *Gain (P)*, *Stability (I)* and *Derivative (D)* settings for *Mains Parallel Operation*. Typically, engine governors need lower gain when in parallel with the Mains supply than they do for single set operation or paralleling with other generators.

For information regarding calibrating these settings, refer section 4.9.3.1.1 entitled *Adjusting Gain (P)*, *Stability (I)* and *Derivative (D)* for more information.

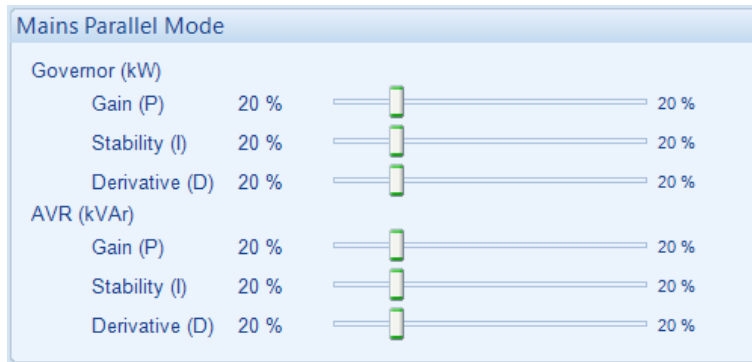

Parameter	Description
Governor (kW) Gain (P) Stability (I) Derivative (D)	The setting for the <i>Gain (P)</i> , <i>Stability (I)</i> and <i>Derivative (D)</i> of the control loop used for the kW control when running in <i>Mains Parallel Mode</i> .
AVR (kvar) Gain (P) Stability (I) Derivative (D)	The setting for the <i>Gain (P)</i> , <i>Stability (I)</i> and <i>Derivative (D)</i> of the control loop used for the kvar control when running in <i>Mains Parallel Mode</i> .

### 4.9.6 LOAD CONTROL (SINGLE SET)

#### Commissioning Screen

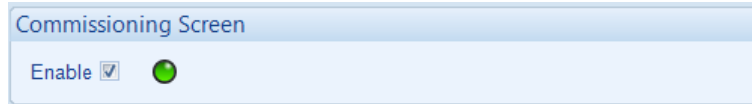

**NOTE:** For further details and instructions on Commissioning Screen, refer to DSE Publication: *057-301 DSE8620 MKII Operators Manual* which is found on our website: [www.deepseaelectronics.com](http://www.deepseaelectronics.com)

Parameter	Description
Enable	<input type="checkbox"/> = Commissioning screens are not shown on the module display <input checked="" type="checkbox"/> = The commissioning screens are shown at the bottom of the <i>Generator</i> section on the module display. These pages are useful for the commissioning and troubleshooting of a load share system.

#### Mains Stability

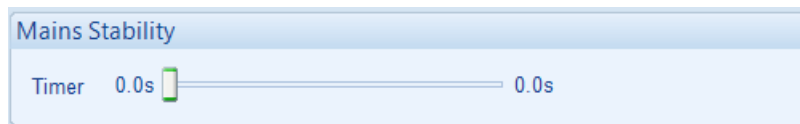

Parameter	Description
Mains Stability Timer	This is the time the DSE8600 module takes to average the Mains kilowatt during the peak lopping or peak shaving. It is used to prevent the generator kilowatt change so rapidly when the mains is unstable, instead a rolling average is used as the target for the mains rather than the actual mains kW.

### 4.9.7 LOAD LEVELS

#### Analogue Drive

Analogue Drive	
Governor	0.0 %
AVR	0.0 %

Parameter	Description
Governor Analogue Drive	<p>Shows the percentage of the module's range of adjustment over the governor (set by SW2) to run the generator at the required frequency or kW level for load sharing.</p> <p>For example, with an SW2 = 3 (<math>\pm 2 V_{DC}</math>) for the <i>Analogue Governor Output</i> and a <i>Governor Analogue Drive Percentage</i> = -50%, means that the <i>Analogue Governor Output</i> is made to change by -1 <math>V_{DC}</math> from the SW1 (Centre) voltage</p> <p>Typical magnitudes at full load, with the switchgear closed and running in <i>Isochronous Load Sharing</i> or <i>Mains Parallel Mode</i> operation are as follows:</p> <ul style="list-style-type: none"> <li>• No more than 10% when there is no external governor droop enabled</li> <li>• No more than 30% when external governor droop is enabled</li> </ul> <p>Typical magnitude at no load, with the switchgear closed and <i>Frequency Droop</i> enabled within the module's configuration are follows:</p> <ul style="list-style-type: none"> <li>• No more than 85%</li> </ul>
AVR Analogue Drive	<p>Shows the percentage of the module's range of adjustment over the AVR (set by SW2) to run the generator at the required voltage or kvar level for load sharing.</p> <p>For example, with an SW2 = 3 (<math>\pm 2 V_{DC}</math>) for the <i>Analogue AVR Output</i> and a <i>AVR Analogue Drive Percentage</i> = +75%, means that the <i>Analogue AVR Output</i> is made to change by +1.5 <math>V_{DC}</math> from the SW1 (Centre) voltage</p> <p>Typical magnitudes at full load, with the switchgear closed and running in <i>Isochronous Load Sharing</i> or <i>Mains Parallel Mode</i> operation are as follows:</p> <ul style="list-style-type: none"> <li>• No more than 10% when there is no external AVR droop enabled</li> <li>• No more than 30% when external AVR droop is enabled</li> </ul> <p>Typical magnitude at no load, with the switchgear closed and <i>Voltage Droop</i> enabled within the module's configuration are follows:</p> <ul style="list-style-type: none"> <li>• No more than 85%</li> </ul>

### 4.9.7.1 MULTI SET MODE

#### Levels

**NOTE:** The *Load Level* settings (excluding the *Minimum Load Level* setting) only have effect when a digital input is configured for *Mains Parallel Mode* instructing the module to operate in fixed export mode with the utility supply. For more information on this application, refer to DSE Publication: *056-054 DSE8x10 in Fixed Export (Base Load)* which is found on our website: [www.deepseaelectronics.com](http://www.deepseaelectronics.com)

For further details on how to configure the different power modes and their operation, refer to the sections entitled *Power Control* and *Voltage and Reactive Power Control* elsewhere in this document.

#### Generator

Parameter	Description
Mode	<b>NOTE:</b> In <i>Multi Set Mode</i> this option is not available.
Power Control Mode	Allows selection of the <i>Power Control Mode</i> when running in <i>Mains Parallel Mode</i> . This is also selectable by activation of a configured digital input or via the <i>Running Editor</i> .
Reactive Power Control Mode	Allows selection of the <i>Reactive Power Control Mode</i> when running in <i>Mains Parallel Mode</i> . This is also selectable by activation of a configured digital input or via the <i>Running Editor</i> .
Spinning Reserve	The power available over and above the load requirements on the bus. The load demand scheme will start further sets to ensure that this margin is maintained.
Spinning Capacity	The minimum power that will be available on the bus (this setting normally exceeds spinning reserve).
Minimum Load Level	The kW load level the generator starts to ramp from when its switchgear closes. It is also the kW load level when the generator's switchgear opens during ramping down and going off load.
Maximum Load Level	The maximum kW load level to be produced when running in <i>Mains Parallel Mode</i> .
Maximum VAr Level	The maximum kvar load level to be produced when running in <i>Mains Parallel Mode</i> .
Power Factor	The power factor the generator is to maintain when running in <i>Mains Parallel Mode</i> .

**VDE Levels**

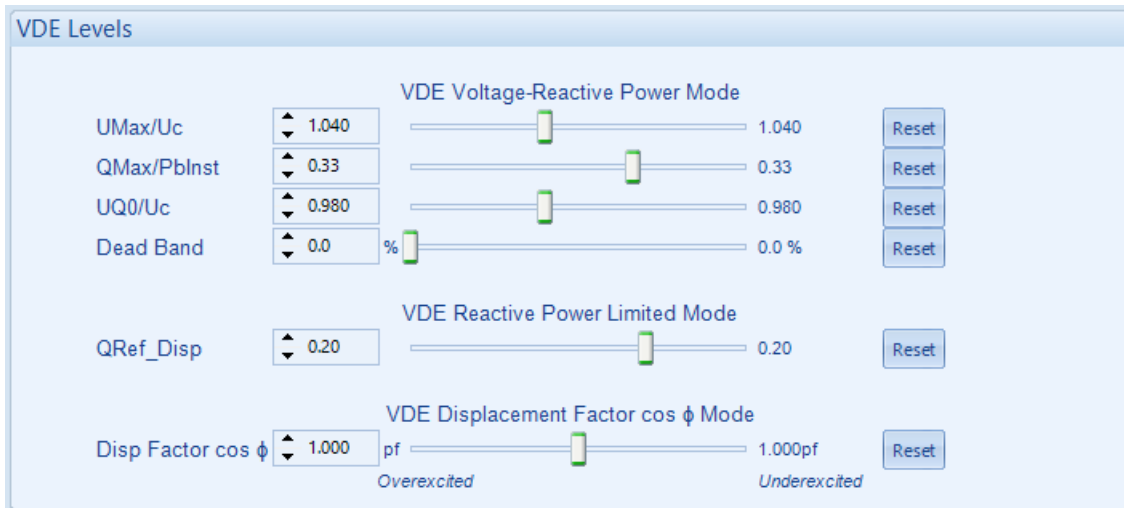

Parameter	Description
UMax/Uc	The voltage at which the maximum required reactive power will be generated.
QMax/Pbinst	The maximum required reactive power.
UQ0/Uc	The offset of the control curve along the x axis, set remotely by the grid operator to define the operating voltage of the grid at the connection point. In operation the red curve will be positioned as shown by the dotted yellow curve but has to be shown referenced to 1.00 because of the definition of the other parameters.
Dead Band	The dead band represents a range of voltage levels within which the control system does not take any corrective action. This means that minor fluctuations in voltage within this band are tolerated without triggering a response.
QRef_Displacement	Required target protection curve. The displacement of the horizontal from Qref.
Disp Factor cos φ	The power factor correction whether it is leading (under excited) or lagging (overexcited).

**Ramp Rates**

**NOTE:** These adjustable parameters do not change the module's configuration settings. These settings enable the user to change the values dynamically via SCADA or the module's internal PLC based on operating requirements.

The screenshot displays a configuration window titled "Ramp Rates". It contains four rows of controls:

- Ramp Up Rate:** A numeric input field showing "3.00", a unit of "%/s", a slider, and a "Reset" button.
- Ramp Down Rate:** A numeric input field showing "3.00", a unit of "%/s", a slider, and a "Reset" button.
- Power Ramp on Setpoint Change:** A numeric input field showing "50.00", a unit of "%/s", a slider, and a "Reset" button.
- Reactive Power Ramp on Setpoint Change:** A numeric input field showing "50.00", a unit of "%/s", a slider, and a "Reset" button.

Parameter	Description
Ramp Up Rate	The rate at which the generator is ramped onto the load when not running in droop.
Ramp Down Rate	The rate at which the generator is ramped off the load when not running in droop.
Power Ramp on Setpoint Change	When changing between <i>Power Control</i> modes or changing the set point, the <i>Ramp Rate</i> defines how fast the output power changes in percentage points per second.
Reactive Power Ramp on Setpoint Change	When changing between <i>Reactive Power Control</i> modes or changing the set point, the <i>Ramp Rate</i> defines how fast the output power changes in percentage points per second.

### 4.9.7.2 SINGLE SET MODE

#### Levels

Parameter	Description
Mode	Allows selection of the following modes <b>Generator:</b> <b>Mains:</b>
Power Control Mode	Allows selection of the <i>Power Control Mode</i> when running in <i>Mains Parallel Mode</i> . This is also selectable by activation of a configured digital input or via the <i>Running Editor</i> .
Reactive Power Control Mode	Allows selection of the <i>Reactive Power Control Mode</i> when running in <i>Mains Parallel Mode</i> . This is also selectable by activation of a configured digital input or via the <i>Running Editor</i> .
Minimum Load Level	The kW load level the generator starts to ramp from when its switchgear closes. It is also the kW load level when the generator's switchgear opens during ramping down and going off load.
Maximum Load Level	The maximum kW load level to be produced when running in <i>Mains Parallel Mode</i> .
Maximum VAr Level	The maximum kvar load level to be produced when running in <i>Mains Parallel Mode</i> .
Power Factor	The power factor the generator is to maintain when running in <i>Mains Parallel Mode</i> .

**VDE Levels**

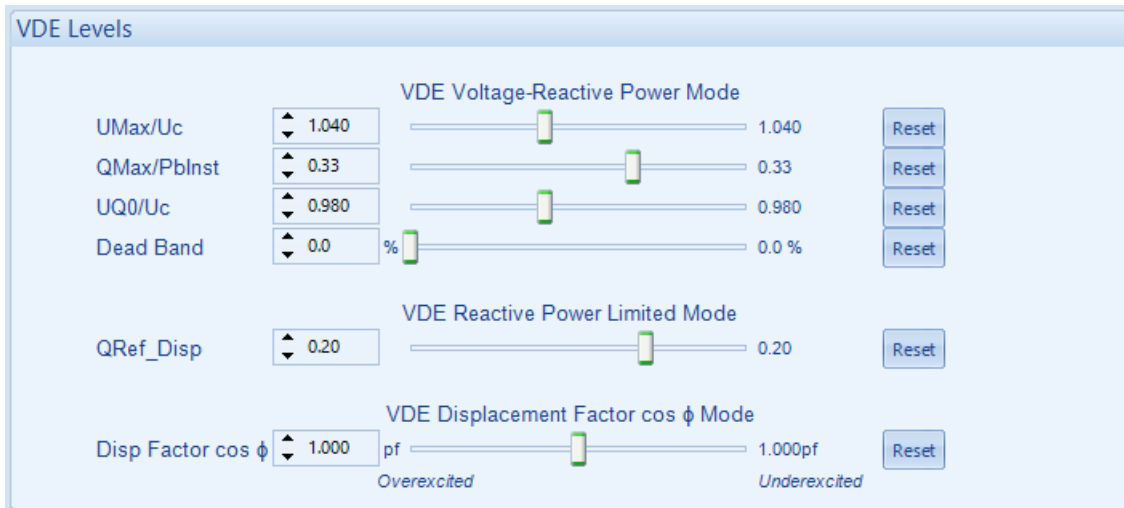

Parameter	Description
UMax/Uc	The voltage at which the maximum required reactive power will be generated.
QMax/Pbinst	The maximum required reactive power.
UQ0/Uc	The offset of the control curve along the x axis, set remotely by the grid operator to define the operating voltage of the grid at the connection point. In operation the red curve will be positioned as shown by the dotted yellow curve but has to be shown referenced to 1.00 because of the definition of the other parameters.
Dead Band	The dead band represents a range of voltage levels within which the control system does not take any corrective action. This means that minor fluctuations in voltage within this band are tolerated without triggering a response.
QRef_Displacement	Required target protection curve. The displacement of the horizontal from Qref.
Disp Factor cos φ	The power factor correction whether it is leading (under excited) or lagging (overexcited).

**Ramp Rates**

**NOTE:** These adjustable parameters do not change the module’s configuration settings. These settings enable the user to change the values dynamically via SCADA or the module’s internal PLC based on operating requirements.

The screenshot displays a configuration window titled "Ramp Rates". It contains four rows, each representing a different ramp rate parameter. Each row includes a label, a numeric input field with up/down arrows, a unit of "%/s", a slider control, a final value, and a "Reset" button.

Parameter	Value	Unit	Reset
Ramp Up Rate	3.00	%/s	Reset
Ramp Down Rate	3.00	%/s	Reset
Power Ramp on Setpoint Change	50.00	%/s	Reset
Reactive Power Ramp on Setpoint Change	50.00	%/s	Reset

Parameter	Description
Ramp Up Rate	The rate at which the generator is ramped onto the load when not running in droop.
Ramp Down Rate	The rate at which the generator is ramped off the load when not running in droop.
Power Ramp on Setpoint Change	When changing between <i>Power Control</i> modes or changing the set point, the <i>Ramp Rate</i> defines how fast the output power changes in percentage points per second.
Reactive Power Ramp on Setpoint Change	When changing between <i>Reactive Power Control</i> modes or changing the set point, the <i>Ramp Rate</i> defines how fast the output power changes in percentage points per second.

### 4.9.8 DROOP (MULTI SET)

This section displays the module's Droop settings for frequency and voltage.

**Droop**

**Frequency Droop**

Gain	20 %	<input type="range" value="20"/>	20 %
Stability	20 %	<input type="range" value="20"/>	20 %
Ramp	0.1 %	<input type="range" value="0.1"/>	0.1 %
Output Offset	0.00 %	<input type="range" value="0.00"/>	0.00 %

**Voltage Droop**

Gain	20 %	<input type="range" value="20"/>	20 %
Stability	20 %	<input type="range" value="20"/>	20 %
Ramp	0.1 %	<input type="range" value="0.1"/>	0.1 %
Output Offset	0.00 %	<input type="range" value="0.00"/>	0.00 %

Parameter	Description
Frequency Droop  Governor (kW) Gain (P) Stability (I) Derivative (D)	The settings for the Gain (P), Stability (I) and Derivative (D) of the control loop used for the control of Frequency Droop.
Voltage Droop  Governor (kW) Gain (P) Stability (I) Derivative (D)	The settings for the Gain (P), Stability (I) and Derivative (D) of the control loop used for the control of Voltage Droop.

### 4.9.9 DE-RATE

#### Watts

Watts

De-Rate	80 %	<input type="range" value="80"/>
Current De-Rated Power %	80 %	
Configured Power Rating	500 kW	
Current De-Rated Power Rating	400 kW	

Parameter	Description
De-Rate	Select with the mouse and move the cursor to override the De-Rate % to the desired level. 100% represents Full kw Load Rating. Reducing the % reduces the generator's kw capacity to limit the power produced when in Mains Parallel Mode, or when load sharing over the AMSC.
Current De-Rated Power %	The de-rated kw power in percent (%).
Configured Power Rating	The kW Rating of the generator, as configured in the <i>Generator Rating</i> section.
Current De-Rated Power Rating	The kw rating after the De-Rate

#### Var

**NOTE:** The *-kvar Rating* is also derated by the *same De-Rate %* which is used to derate the *+kvar Rating*.

VAr

De-Rate	92 %	<input type="range" value="92"/>
Current De-Rated VAr %	92 %	
Configured VAr Rating	375 kVAr	
Current De-Rated VAr Rating	345 kVAr	

Parameter	Description
De-Rate	Select with the mouse and move the cursor to override the De-Rate % to the desired level. 100% represents Full kvar Rating. Reducing the % reduces the generator's kvar capacity to limit the kvar produced when in Mains Parallel Mode, or when load sharing over the AMSC.
Current De-Rated var %	The de-rated kvar power in percent (%).
Configured var Rating	The kvar Rating of the generator, as configured in the <i>Generator Rating</i> section.
Current De-Rated var Rating	The kvar rating after the De-Rate

## 4.10 ENGINE

This section displays the measurement of the *Engine* parameters. These measurements come from either the module's inputs or from the engine ECU/ECM. For further details on how to configure these items, refer to the section entitled *Application* elsewhere in this document.

<b>Coolant Temperature</b> 81 °C, 178 °F	<b>Plant Battery</b> 13.2 V DC
<b>Oil Pressure</b> 5.16Bar, 74.8 PSI, 516 kPa	<b>Charge Alternator</b> 28.2 V DC
<b>Speed</b> 1499 RPM	<b>Hours Run</b> 1821:33
<b>Fuel Level</b> 73 %	<b>Number Of Starts</b> 578

### 4.10.1 FUEL USE AND EFFICIENCY

This section displays the measurement of the *Fuel Use and Efficiency* parameters. These measurements come from either the module's inputs or from the engine ECU/ECM. For further details on how to configure these items, refer to the section entitled *Fuel Use and Efficiency* under the *Engine* section elsewhere in this document.

<b>Fuel Consumption</b>		
Instantaneous 9.90 l/hr	Trip 10.26 l/hr	
<b>Fuel Use</b>		
Trip 1 litres	Accumulated 29978 litres	
<b>Fuel Efficiency</b>		
Instantaneous 2.60 kWh/l	Trip 2.59 kWh/l	Accumulated 2.30 kWh/l
<b>Run Time Until Empty</b>		
25:13 hh:mm		

## 4.11 FLEXIBLE SENSORS

This section displays the status and instrumentation measured by the module's analogue inputs and the functions they are configured for. For further details on how to configure these items, refer to the section entitled *Analogue Inputs* elsewhere in this document.

Flexible Sensor A
Not Used
Flexible Sensor B
Not Used
Flexible Sensor C
Not Used
Flexible Sensor D
Not Used
Flexible Sensor E
Not Used
Flexible Sensor F
Not Used
Flexible Sensor G
Not Used

## 4.12 CONFIGURABLE CAN INSTRUMENTATION

This section displays the module's readings of the configured *CAN Instrumentation*. This is only available if the module is configured for *Configurable CAN Instrumentation*, the *Enhanced CANbus* option is enabled, and the message is available over the relevant configured CAN bus. For further details on how to configure these items, refer to the section entitled *Configurable CAN Instrumentation* elsewhere in this document.

Configurable CAN Instrumentation		
1	Engine Coolant Temp - ET1	21 °C
2	Engine Oil Pressure - EFL_P1	500 kPa
3	Engine Fuel Used - LFC	Bad Data
4	Engine Speed - EEC1	1500.000 RPM
5	Engine Hours - Hours	0.0 hr
6	Engine Fuel Pressure - EFL_P1	124 kPa
7	Engine Oil Temperature - ET1	32.14723 °C
8	Engine Coolant Pressure - EFL_P1	0.62 kPa
9	Engine Inlet Temp - IC1	Bad Data
10	Engine Coolant Level - EFL_P1	100 %

### 4.13 ALARMS

This section displays the alarms that are currently active on the module.

For information regarding alarm severity, refer to the section entitled *Alarm Types* elsewhere in this document.

#### Alarms

**Shutdown Alarms**

- Emergency Stop
- Oil Pressure Sensor Open Circuit
- Temp Sender Open Circuit Alarm

**Electrical Trip Alarms**

**Warning Alarms**

Alarms that are active on the unit are grouped based on their type. For example, the *Emergency Stop* alarm appears in the *Shutdown Alarms* list because it has generated a *Shutdown* alarm type.

#### Reset Electrical Trip

**NOTE:** For further details on how this function is configured, refer to section 3.18.3 entitled *Reset Electrical Trip* for more information.

**Reset Electrical Trip**

Reset Count: 0

Time Period: 05:00

Parameter	Description
Reset Count	The number of times any electrical trips has been reset whilst the generator is running to enable it to go back on load. The counter goes to zero upon the generator stopping.
Time Period	The time interval for the <i>Reset Count</i> . It is not possible for resets to occur until the generator has stopped if the Reset Count limit is reached within configured Time Period.

## 4.14 ENGINE ALARMS

The *Engine Alarms* page is subdivided into smaller sections. Select the required section with the mouse.

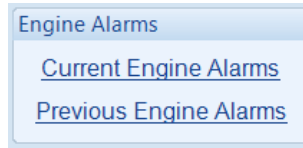

### 4.14.1 CURRENT ENGINE ALARMS

This section displays the list of active *ECU Current DTCs* (Diagnostic Trouble Codes) which are being read from the engine's ECU. *ECU Current DTCs* are DM1 messages and are only read when the engine's ECU is awake (powered up). For information, refer to DSE publication: **057-004 Electronic Engines and DSE Wiring** which is found on the DSE website: [www.deepseaelectronics.com](http://www.deepseaelectronics.com).

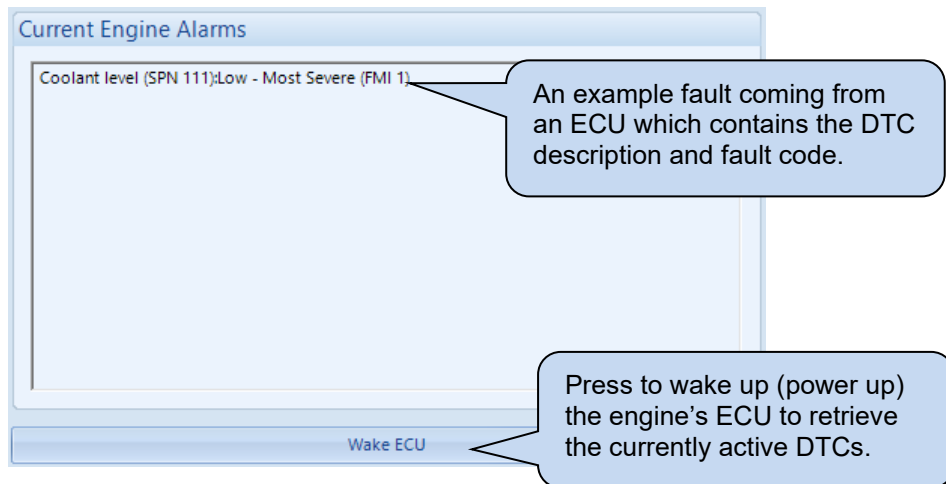

**NOTE:** The ECU Override remains powered for two minutes after pressing the Wake ECU button in Stop Mode.

#### 4.14.2 PREVIOUS ENGINE ALARMS

This section displays the list of active *ECU Previous DTCs* (Diagnostic Trouble Codes) which are being read from the engine's ECU. *ECU Previous DTCs* are DM2 messages and are only read when the engine's ECU is awake (powered up). For information, refer to DSE publication: **057-004 *Electronic Engines and DSE Wiring*** which is found on the DSE website: [www.deepseaelectronics.com](http://www.deepseaelectronics.com).

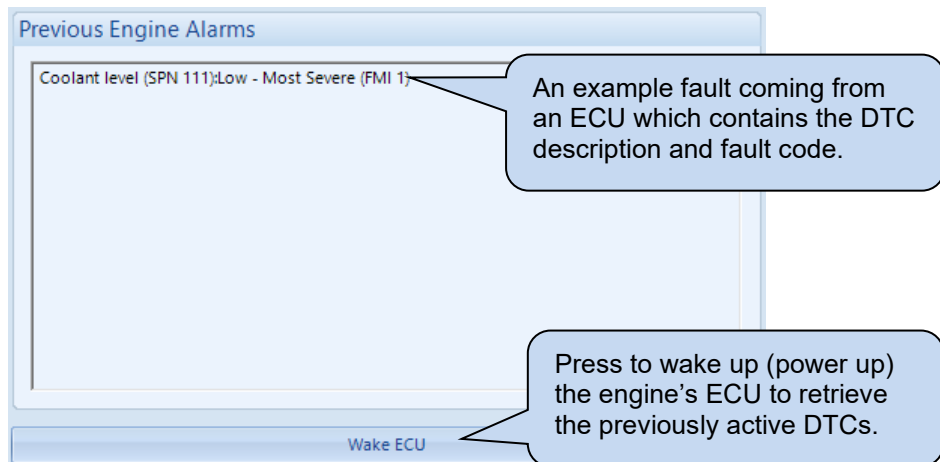

## 4.15 STATUS

This section displays the status information about the module.

<b>Supervisor State</b> Alarm Stop	<b>Application</b> Single Set Mode
<b>Engine/Generator State</b> Failed To Stop	<b>Software Version</b> Main version: 1.0.132 Bootloader: 1.3.2 Co-Processor: 1.0.7 Bootstrap: 1.3.2
<b>Mains Detection State</b> Mains Failed	<b>Module ID</b> DSEG8600
<b>Load Switching State</b> Generator And Mains Open	<b>Mode</b> 
<b>Protections</b> Enabled	
<b>Heater Fitted</b> Heater Fitted	

### 4.16 EVENT LOG

This section displays the events which are recorded with the module's event log along with the time, date, and engine hours in which they occurred. For further details on how what events are recorded, refer to the section entitled *Event Log* elsewhere in this document.

#	Date	Time	Hours Run	Event	Details
1	12/02/2019	11:00:26	1821:21	Start	Engine Started
2	12/02/2019	10:46:37	1821:21	Stop	Engine Stopped
3	12/02/2019	10:46:01	1821:21	Start	Engine Started
4	12/02/2019	10:45:56	1821:21	Warning	ECU Amber
5	12/02/2019	10:41:31	1821:21	Warning	MSC Failure
6	12/02/2019	10:38:08	1821:21	Stop	Engine Stopped
7	12/02/2019	10:37:08	1821:21	Start	Engine Started
8	12/02/2019	10:19:37	1821:21	Stop	Engine Stopped
9	12/02/2019	10:19:15	1821:21	Start	Engine Started
10	11/02/2019	16:40:25	1821:21	Stop	Engine Stopped
11	11/02/2019	16:31:28	1821:12	Start	Engine Started
12	11/02/2019	16:20:21	1821:12	Stop	Engine Stopped
13	11/02/2019	16:14:34	1821:06	Start	Engine Started
14	11/02/2019	15:49:13	1821:06	Stop	Engine Stopped
15	11/02/2019	15:43:30	1821:00	Start	Engine Started
16	11/02/2019	09:56:56	1821:00	Stop	Engine Stopped
17	11/02/2019	09:02:56	1820:06	Start	Engine Started
18	11/02/2019	08:53:26	1820:06	Warning	MSC Failure
19	08/02/2019	14:48:53	1820:06	Stop	Engine Stopped
20	08/02/2019	14:40:40	1819:57	Start	Engine Started
21	08/02/2019	14:26:48	1819:57	Stop	Engine Stopped
22	08/02/2019	13:03:46	1818:36	Start	Engine Started
23	08/02/2019	12:03:59	1818:36	Stop	Engine Stopped
24	08/02/2019	11:30:45	1818:03	Start	Engine Started
25	08/02/2019	11:29:54	1818:03	Stop	Engine Stopped
26	08/02/2019	11:27:29	1818:00	Start	Engine Started

Export to Excel
Export to CSV
Export to PDF
Print event log

Click to save the log to an Excel or csv file for use in an external spreadsheet

Click to save the log to a pdf (Adobe Acrobat) file.

Click to print the log

## 4.17 ENHANCED CANBUS

This section displays the measurement of the *Engine* parameters. These measurements come from the engine ECU/ECM. For further details on how to configure engine ECU/ECM, refer to the section entitled *Application* elsewhere in this document.

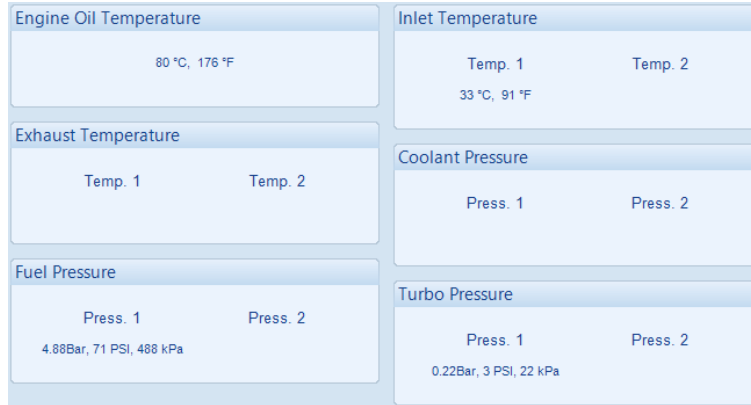

## 4.18 MAINTENANCE

The *Maintenance* section is subdivided into smaller sections. Select the required section with the mouse.



### 4.18.1 RECALIBRATE TRANSDUCERS (A TO G)

This section allows the analogue sensor inputs of the module to be calibrated to remove inaccuracies caused by the tolerance of the sensor devices. While the engine is running, the instruments are calibrated, and reference needs to be made to a third-party accurate sensing device to ensure accurate recalibration.

The screenshot displays the recalibration interface for transducers A through G. It consists of five main sections, each with a horizontal slider and a callout box:

- Analogue Input A:** The slider is positioned at the left end, labeled "0 Bar". A callout box states: "The value for the sensor as displayed on the module's display".
- Analogue Input B:** The slider is in the center, labeled "Not configured". A callout box states: "Adjust the slider to alter the module's calibration for the sensor".
- Analogue Input C:** The slider is in the center, labeled "Fault".
- Analogue Input D:** The slider is positioned at approximately 20% from the left, labeled "20 %".
- Reset:** A button labeled "Reset to Default" is located at the bottom. A callout box states: "Click to reset all the recalibration settings back to default."

### 4.18.2 EXPANSION CALIBRATION

This section allows the analogue sensor inputs of the DSE2130 and DSE2131 expansion modules to be calibrated to remove inaccuracies caused by the tolerance of the sensor devices. While the engine is running, the instruments are calibrated, and reference needs to be made to a third-party accurate sensing device to ensure accurate recalibration.



### 4.18.3 HOURS RUN AND NUMBER OF STARTS

This section allows the Hours Run and Number of Starts to be customised on the controller. Typically, this is used when fitting a new controller to an older engine so that the controller display matches the amount of work previously done by the system.

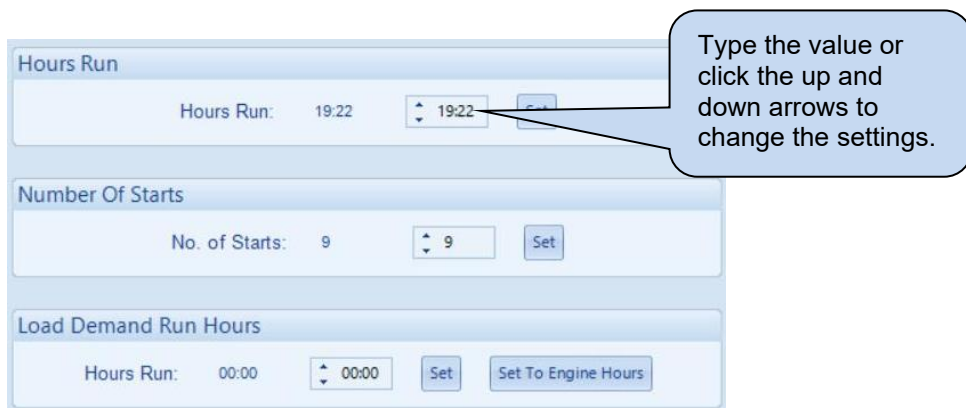

### 4.18.4 TIME

This section allows the date and time to be adjusted on the controller.

The screenshot displays a SCADA interface for time adjustment, divided into four sections:

- Module Date:** Shows the current date as 05/04/2019. A callout indicates: "Display of the module's current date and time".
- Module Time:** Shows the current time as 12:38:16. A callout indicates: "Type the new date / time or click the up and down arrows to change the settings".
- Set Date And Time:** Contains two dropdown menus for "Date" (05/04/2019) and "Time" (12:38:12), and a "Set" button. A callout points to the dropdowns: "Type the new date / time or click the up and down arrows to change the settings". Another callout points to the "Set" button: "Click Set to adjust the module to the selected date/time."
- Set To PC Time:** Shows the PC's date (05/04/2019) and time (13:38:00), and a "Set To PC Time" button. A callout points to the button: "Click Set to adjust the module to the date/time that the PC is set to."

### 4.18.5 ACCUMULATED INSTRUMENTATION

This section allows the generators accumulated instrumentation and the Fault Ride Through Events counter to be adjusted on the controller.

The screenshot displays a control interface for accumulated instrumentation, organized into five horizontal panels. Each panel includes a title, a current value, a control input, and a 'Set' button. Callout boxes provide instructions for each control element.

- kWh:** Shows a current value of 30.6 kWh. A callout points to the '30.6' value, stating: "Display of the module's current value for the parameter."
- kVAh:** Shows a current value of 38.2 kVAh. A callout points to the input field containing '38.2', stating: "Type the new value or click the up and down arrows to change the settings."
- kVArh:** Shows a current value of 22.7 kVArh. A callout points to the 'Set' button, stating: "Click Set to adjust the module to the selected value."
- Fault Ride Through:** Shows a current value of 19 Events. A callout points to the 'Set' button, stating: "Click Set to adjust the module to the selected value."
- Reset:** Contains a 'Reset all values to zero' button. A callout points to this button, stating: "Click to reset all the accumulated instrumentation counters to zero."

### 4.18.6 FULE USE AND EFFICIENCY

This section allows the total fuel used value to be adjusted on the controller.

The screenshot displays a control interface with three main sections: Fuel Use, Fuel Efficiency, and Reset. Each section has associated controls and callout boxes explaining their functions.

- Fuel Use:** Features a label "Fuel Use:" followed by a numeric input field with up and down arrow buttons. A callout box points to these arrows, stating: "Type the new value or click the up and down arrows to change the settings."
- Fuel Efficiency:** Features a label "Fuel Efficiency:" followed by a numeric input field containing "0.00 kWh/l" and a unit dropdown menu. A callout box points to the input field, stating: "Type in new value or click the up down arrows to change the setting."
- Reset:** Features a button labeled "Reset all values to zero". A callout box points to this button, stating: "Click to reset all the accumulated instrumentation counters to zero."

### 4.18.7 MAINTENANCE ALARM RESET

This section allows the module's three maintenance alarms to be reset and when the alarm is due to activate.

The screenshot displays three stacked panels for maintenance reset. Each panel contains the following information:

- Oil Filter:** Running Time Until Next Maintenance: 500:00; Date Of Next Maintenance: 04/10/2019 22:38:13. Callout: "The number of engine hours or date until the maintenance alarm activates."
- Fuel Filter:** Running Time Until Next Maintenance: 1000:00; Date Of Next Maintenance: 04/10/2019 22:38:13. Callout: "Reset the maintenance alarm based upon the module's configuration."
- Air Filter:** Running Time Until Next Maintenance: 1000:00; Date Of Next Maintenance: 04/04/2020 08:14:13.

Each panel features a "Reset" button and a note: "Press reset to schedule next maintenance, based upon module's maintenance configuration."

### 4.18.8 ELECTRONIC ENGINE CONTROLS

This section allows settings within the engine's ECU to be altered when supported.

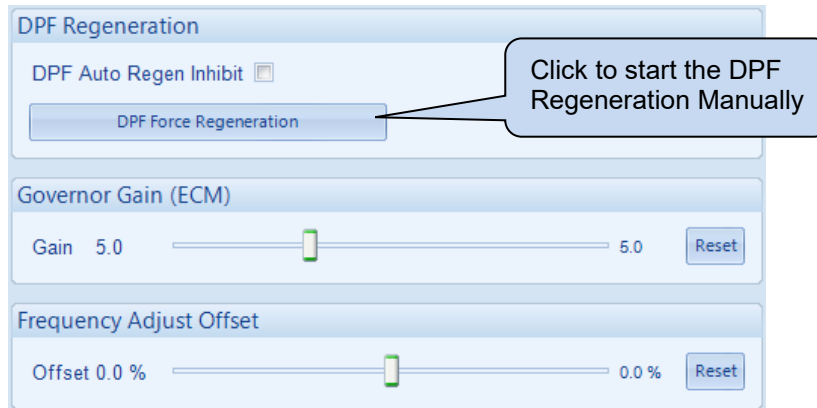

Parameter	Description
DPF Auto Regen Inhibit	<input type="checkbox"/> = The ECU's DPF Auto Regeneration happens automatically. <input checked="" type="checkbox"/> = The ECU's DPF Auto Regeneration is inhibited from activating.
Governor Gain (ECM)	The setting for the <i>Gain (P)</i> of the ECU/ECM's control loop over the engine speed.
Frequency Adjust Offset	A positive/negative offset that is applied to the entire ECU/ECM's droop setting as percentage its configured nominal speed.  An <i>Offset</i> of -1% with a nominal speed of 1500 RPM would result in the entire ECU's droop curve being offset by 15 RPM.

### 4.18.9 MODULE PIN

**⚠ CAUTION!: If the module PIN is lost or forgotten, it is no longer possible to access or make changes to the module!**

This section allows the user to configure a PIN (Personal Identification Number) for reading and writing to the module. This PIN must be entered to access the modules *Main Front Panel Configuration Editor* or, when writing a configuration or changing a value in SCADA using the DSE Configuration Suite PC Software.

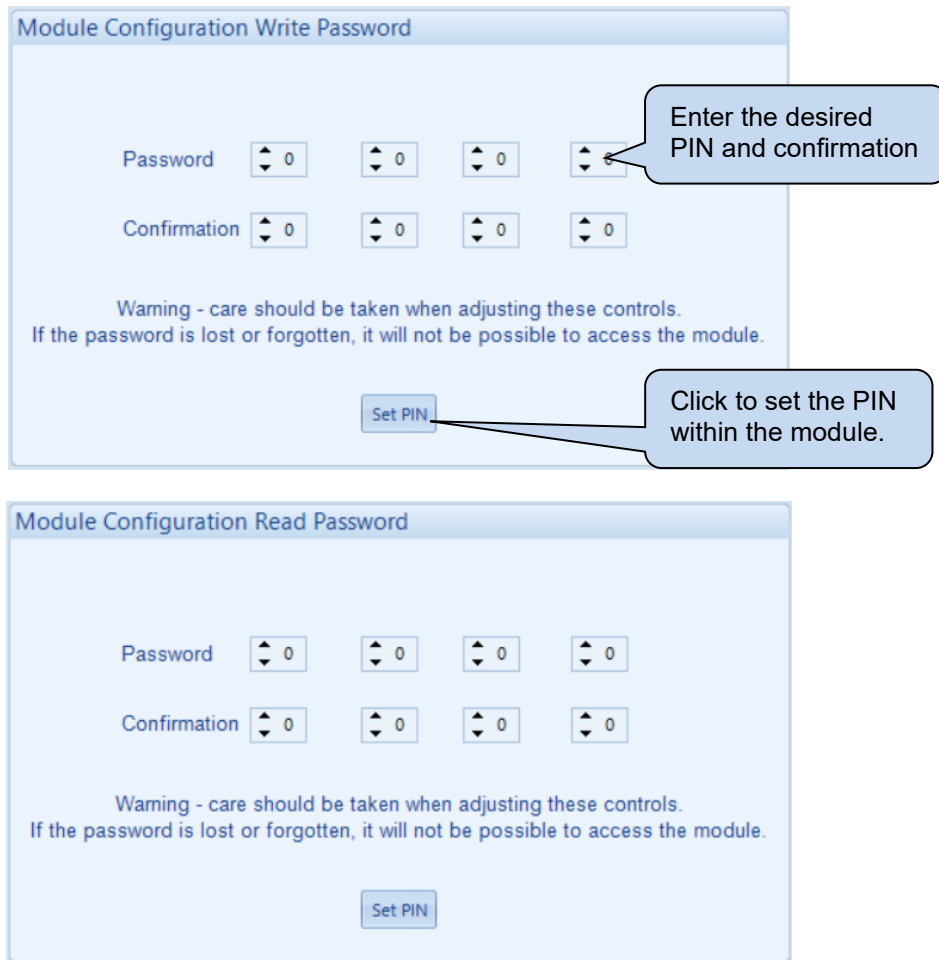

## 4.19 COMMUNICATIONS INFORMATION

This section displays the information about the configuration of the module's ethernet port. For further details on how to configure the module's ethernet port, refer to the section entitled *Ethernet* elsewhere in this document.

<b>IP address</b> 192 . 168 . 1 . 100	<b>MAC Address</b> E8 : A4 : C1 : 2 : 8D : 7
<b>Subnet Mask</b> 255 . 255 . 255 . 0	<b>DNS</b> 8 . 8 . 8 . 8
<b>Host</b> DSE Host	<b>MODBUS Preferred IP Address</b> 192 . 168 . 1 . 99
<b>Domain</b> DSE Module	<b>MODBUS Connection Port</b> 502
<b>Gateway</b> 192 . 168 . 1 . 1	<b>DHCP</b> Off
	<b>TCP Vendor</b> DSE Vender

## 4.20 DATA LOG

This section displays and temporarily records the instruments configured within the module's *Data Logging* facility to the PC. The data which is temporarily recorded is only for the duration in which the *Data Log* section is viewed. For further details on how to configure these items, refer to the section entitled *Data Logging* elsewhere in this document.

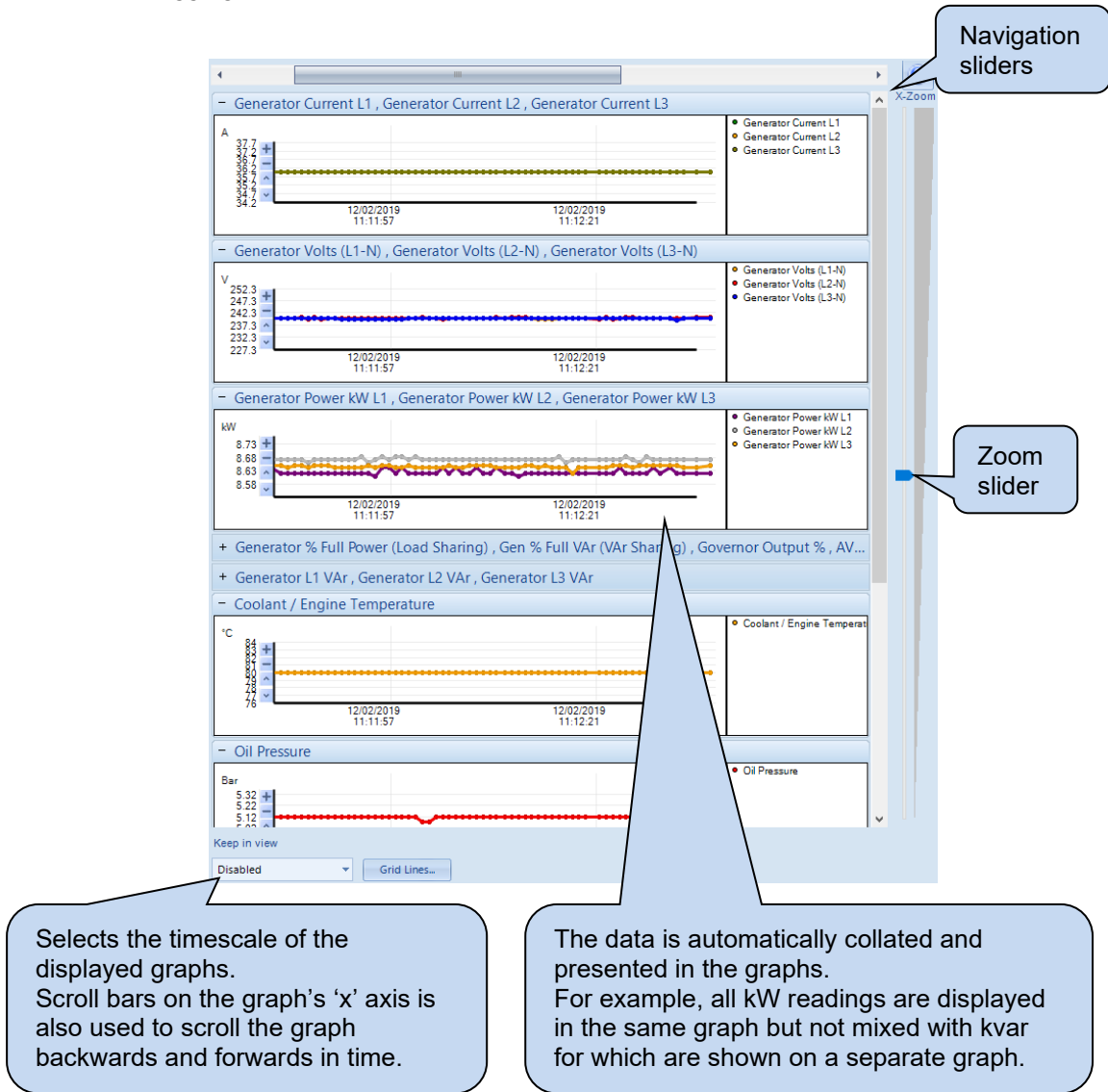

### 4.20.1 DATA LOG STATUS

This section displays the information module's *Data Logging* function. For further details on how to configure the module's Data Logging function, refer to the section entitled *Data Logging* elsewhere in this document.

<b>Internal Memory Capacity</b> 2048 kB	<b>Data Logging Status</b> Logging
<b>Remaining Data Log Memory</b> Space remaining in Internal memory: 2032 kB	<b>Data Log Mode</b> Keep New
<b>Remaining Data Log Time</b> 7h 30m	<b>USB Drive Status</b> Not Fitted
<b>Total Log Pages Available</b> 128	<b>Data Log Destination</b> Internal
<b>Current Page Usage</b> 4.473 kB	

## 4.21 AVR

The AVR section is subdivided into smaller sections.  
Select the required section with the mouse.

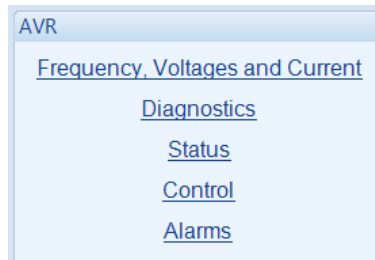

### 4.21.1 FREQUENCY, VOLTAGES AND CURRENT

**NOTE:** The *Feedback Voltages* might not indicate the true *Generator Voltage* values. The *Feedback Voltage* instruments reading depend on the CAN AVR device being used and the way it is connected to the AC alternator. The DSEA108 supports only single-phase voltage sensing connected as *Ph-N* or *Ph-Ph*. The DSEA109 supports single phase or three phase voltage sensing. For further details, refer to DSE Publication: *057-281 DSEA108 Operator Manual* or *057-295 DSEA109 Operator Manual* available on our website: [www.deepseaelectronics.com](http://www.deepseaelectronics.com)

Frequency		
50.1 Hz		
Feedback Voltage		
L1 - L2 209.4 V	L2 - L3 209.3 V	L3 - L1 209.2 V
Average 209.3 V		
Droop Current		
0.00 A		
Excitation Voltage		
12.9 V		
Auxiliary Voltage		
173.7 V		

### 4.21.2 DIAGNOSTICS

<b>External Control</b>		
Potentiometer +++	Voltage 0.02 V	
<b>Set Points</b>		
Voltage 120.0 V	Droop 3.0 %	UFRO Knee 42.7 Hz
Proportional 80.6	Integral 9.7	Derivative 50.0
<b>Excitation Output</b>		
Off Load Duty Cycle 8.0 %	Maximum Duty Cycle 100.0 %	
<b>Soft Start</b>		
Ramp Start Point (% of set point) 27.0 %	Ramp Rate (%/s) 30.0 %	

### 4.21.3 STATUS

<b>Status</b>	
<b>Software Version</b>	
2.0.2	
<b>Configuration</b>	
Active Configuration 0	Active Stability Configuration 1

### 4.21.4 CONTROL

**NOTE:** The *Active Configuration Selection* and the *Active Stability Configuration Selection* SCADA settings are only adjustable if they are enabled within the DSE CAN AVR's configuration. For further details, refer to DSE Publication: *057-283 DSEA108 Software Manual* or *057-294 DSEA109 Software Manual* available on our website: [www.deepseaelectronics.com](http://www.deepseaelectronics.com)

Set Points			
Droop	3.0 %		3.0 %
Proportional	80.6		80.6
Integral	9.7		9.7
Derivative	50.0		50.0

Excitation Output			
Off Load Duty Cycle	8.0 %		8.0 %
Maximum Duty Cycle	100.0 %		100.0 %

Soft Start			
Ramp Start Point (% of set point)	27.0 %		27.0 %
Ramp Rate (%/s)	30.0 %		30.0 %

Configuration			
Active Configuration	0		0
Active Stability Configuration	1		1

### 4.21.5 AVR ALARMS

AVR Alarms
Start-up failed trip

## 4.22 EXPANSION

The *Expansion* section is subdivided into smaller sections. Select the required section with the mouse.



The selected section displays the status of the expansion module's inputs/outputs/LEDs etc and the functions they are configured for. For further details on how to configure these items, refer to the section entitled *Expansion* in the *Edit Config* section elsewhere in this document. An example status of a DSE2157 Output Expansion is shown below.

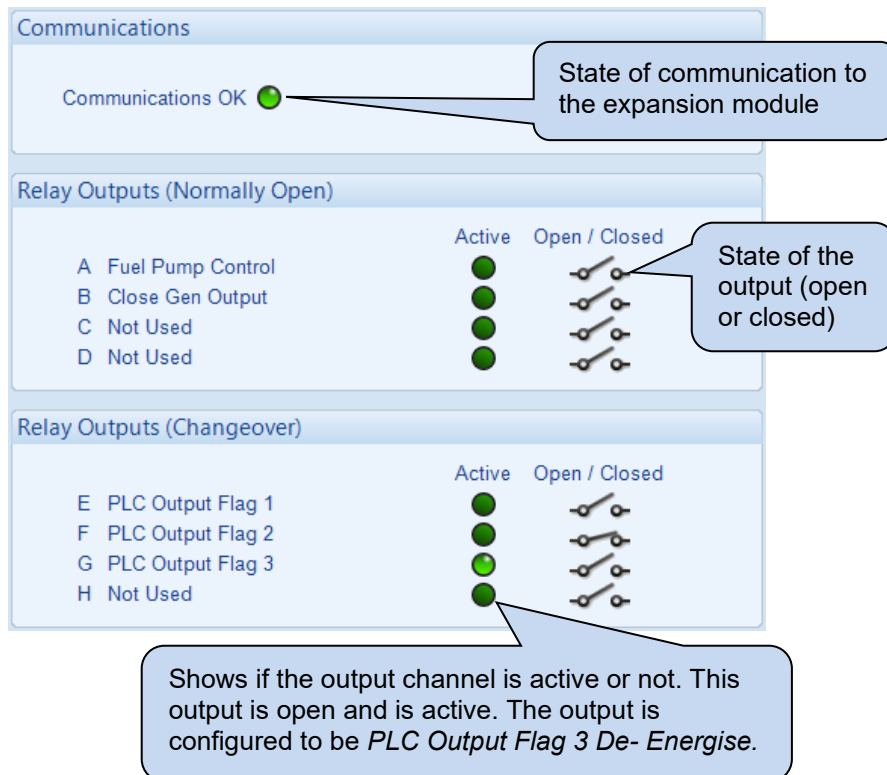

## 5 ALARM TYPES

The protection included with the DSE control modules provides increasing levels of notification, depending upon the severity of the situation:

Alarm Type	Description
Indication	No audible alarm or common warning signal occurs. <i>Indication</i> alarms are only used to illuminate indicators, activate outputs, or checked by the module's internal PLC.
Warning	Audible alarm and common alarm signal is generated. The set continues to run. <i>Warning alarms</i> are used to draw the operator's attention to a minor issue or to a problem that may escalate to an Electrical Trip or Shutdown Alarm if left untreated.
Warning & Trip Gen / Bus Breaker	Audible alarm and common alarm signal is generated, and then the gen / bus breaker is tripped. When the alarm conditions have cleared, the bus breaker is allowed to automatically reclose in auto mode.
Warning & Trip Mains Breaker	Audible alarm and common alarm signal is generated, and then the mains breaker is tripped. When the alarm conditions have cleared, the mains breaker is allowed to automatically reclose in auto mode.
Electrical Trip	Audible alarm and common alarm signal is generated. The set is taken off load and the cooling timer begins, after which the set is stopped. <i>Electrical Trip alarms</i> are series issues that require the set to be taken off load. As the name implies, this is often electrical faults that occur 'after' the load switch. The set is allowed to cool before stopping.
Shutdown	Audible alarm and common alarm signal is generated. The set is taken off load and immediately stopped. <i>Shutdown alarms</i> are serious issues that demand immediate stopping of the generator. For instance, Emergency Stop or Overspeed alarms require immediate shutdown.

## 6 ALARM ARMING

The protections on the DSE module are active during their configured *Alarm Arming* setting. The table below shows the timing segment for the different *Alarm Arming* options with regards to the generator status.

Timing Segment	Stopped	Start Delay	ECU Wake Up Delay	Preheat	Cranking	Safety on Delay	Idle Running	Idle Running Off	Warming Up	Gen Available	Gen On Load	Cooling	Cooling in Idle
Never													
Always													
When Stationary													
From Starting													
Over frequency / Overspeed Overshoot													
From Safety On													
From Breaker Closed													
From Mains Parallel													

## 6.1 NEVER

The protection is never active on the controller. This is used to disable the protection.

## 6.2 ALWAYS

The protection is always active on the controller. This is used to constantly monitor statuses such as a fuel level switch irrespective of the engine running state.

## 6.3 WHEN STATIONARY

The protection is active from the moment the engine stops until the beginning of engine cranking.

## 6.4 FROM STARTING

The protection is active from the beginning of engine cranking, until the engine stops.

## 6.5 OVERSHOOT

Active during the *Safety Delay* timer, this allows for a temporary raise of the overspeed/over frequency trip points during start-up.

Protection Level	Over Frequency Trip Level	Over Speed Trip Level
Immediate Shutdown	Over Frequency + Overshoot %	Over Speed + Overshoot %
Delayed Shutdown (Overspeed Overshoot Delay)	Over Frequency	Over Speed

### Example

57 Hz *Over Frequency* setting, 10% *Overspeed Overshoot*

During *Safety Delay* a generator frequency above  $(57 \text{ Hz} \times 1.1) = 62.7 \text{ Hz}$  results in an immediate shutdown without delay.

After *Safety delay*, a generator frequency above 57 Hz for the period of the *Generator Transient Delay* results in a shutdown

## **6.6 FROM SAFETY ON**

The protection is active when the set is running at nominal speed, until the engine stops.

## **6.7 FROM BREAKER CLOSED**

The protection is active when the set is running with its switchgear closed.

## **6.8 FROM MAINS PARALLEL**

The protection is active when the set is running with its switchgear closed and a digital input configured for *Mains Parallel Mode* is active.

*This page is intentionally left blank*