



DEEP SEA ELECTRONICS
DSEG4500 & DSEG4501
Compact Single Genset Controller
Operator Manual

Document Number: 057-379

Author: Ian Roberts





Deep Sea Electronics Ltd.

Highfield House
Hunmanby
North Yorkshire
YO14 0PH
England

Sales Tel: +44 (0) 1723 890099

E-mail: sales@deepseaelectronics.com

Website: www.deepseaelectronics.com

DSEG4500 & DSEG4501 Compact Single Genset Controller Operator Manual

© Deep Sea Electronics Ltd.

All rights reserved. No part of this publication may be reproduced in any material form (including photocopying or storing in any medium by electronic means or other) without the written permission of the copyright holder except in accordance with the provisions of the Copyright, Designs and Patents Act 1988.

Applications for the copyright holder's written permission to reproduce any part of this publication must be addressed to Deep Sea Electronics Ltd. at the address above.

The DSE logo and the names DSEGenSet®, DSEATS®, DSEPower® and DSEControl® are UK registered trademarks of Deep Sea Electronics Ltd.

Any reference to trademarked product names used within this publication is owned by their respective companies.

Deep Sea Electronics Ltd. reserves the right to change the contents of this document without prior notice.

Amendments Since Last Publication

Issue No.	Comments
1	Initial Release

Typeface: The typeface used in this document is *Arial*. Care must be taken not to mistake the upper case letter I with the numeral 1. The numeral 1 has a top serif to avoid this confusion.

TABLE OF CONTENTS

SECTION	PAGE
1 INTRODUCTION.....	6
1.1 CLARIFICATION OF NOTATION.....	7
1.2 GLOSSARY OF TERMS.....	7
1.3 BIBLIOGRAPHY	9
1.3.1 INSTALLATION INSTRUCTIONS.....	9
1.3.2 MANUALS	9
1.3.3 TRAINING GUIDES	10
1.3.4 THIRD PARTY DOCUMENTS	10
2 SPECIFICATION.....	11
2.1 PART NUMBERING.....	11
2.2 OPERATING TEMPERATURE.....	11
2.3 REQUIREMENTS FOR UL	12
2.4 TERMINAL SPECIFICATION	12
2.5 POWER SUPPLY REQUIREMENTS.....	13
2.5.1 MODULE SUPPLY INSTRUMENTATION DISPLAY.....	13
2.6 VOLTAGE & FREQUENCY SENSING.....	13
2.7 CURRENT SENSING.....	14
2.7.1 VA RATING OF THE CTS.....	14
2.7.2 CT POLARITY	15
2.7.3 CT PHASING.....	15
2.7.4 CT CLASS.....	16
2.8 INPUTS.....	17
2.8.1 DIGITAL INPUTS	17
2.8.2 ANALOGUE INPUTS	17
2.8.3 CHARGE FAIL INPUT.....	19
2.8.4 MAGNETIC PICK-UP	19
2.9 OUTPUTS.....	20
2.9.1 DC OUTPUTS A & B (FUEL & START).....	20
2.9.2 DC OUTPUTS C, D, E & F.....	20
2.10 COMMUNICATION PORTS	20
2.11 COMMUNICATION PORT USAGE.....	21
2.11.1 USB CONFIGURATION PORT (PC CONFIGURATION).....	21
2.11.2 CAN PORT (J1939).....	22
2.12 ADDING AN EXTERNAL SOUNDER	24
2.13 ACCUMULATED INSTRUMENTATION	25
2.14 DIMENSIONS AND MOUNTING.....	26
2.14.1 DIMENSIONS.....	26
2.14.2 PANEL CUTOUT.....	26
2.14.3 WEIGHT	26
2.14.4 FIXING CLIPS	27
2.15 APPLICABLE STANDARDS	28
2.15.1 ENCLOSURE CLASSIFICATIONS.....	30
3 INSTALLATION.....	31
3.1 USER CONNECTIONS	31
3.2 CONNECTION DESCRIPTIONS	32
3.2.1 DC SUPPLY, DC OUTPUTS & CHARGE FAIL INPUT	32
3.2.2 ANALOGUE SENSOR INPUTS	33
3.2.3 CONFIGURABLE DIGITAL INPUTS & CAN.....	34
3.2.4 GENERATOR & MAINS VOLTAGE & FREQUENCY SENSING	35
3.2.5 CURRENT TRANSFORMERS.....	36
3.2.6 MPU & RS485	36
3.2.7 USB CONFIGURATION (PC CONFIGURATION) CONNECTOR.....	38
3.3 TYPICAL SCHEMATIC DIAGRAM.....	39
3.3.1 DSEG4500 TYPICAL SCHEMATIC DIAGRAMS.....	40

3.3.2	DSEG4501 TYPICAL SCHEMATIC DIAGRAMS.....	42
3.3.3	EARTH SYSTEMS.....	44
3.3.4	TYPICAL 0 MA TO 20 MA AND 0 V TO 10 V SENSOR SCHEMATIC	45
3.4	ALTERNATE G4500/G4501 TOPOLOGY SCHEMATIC DIAGRAMS	48
3.4.1	AUTOMATIC MAINS FAILURE 3 PHASE 4 WIRE	48
3.4.2	AUTOMATIC MAINS FAILURE 3 PHASE 3 WIRE	49
3.4.3	AUTOMATIC MAINS FAILURE 2 PHASE (L1, L2) 3 WIRE	50
3.4.4	AUTOMATIC MAINS FAILURE 2 PHASE (L1, L3) 3 WIRE	51
3.4.5	AUTOMATIC MAINS FAILURE SINGLE PHASE (L1, N) 2 WIRE	52
3.4.6	AUTOMATIC MAINS FAILURE 3 PHASE 4 WIRE	53
3.4.7	REMOTE START 3 PHASE 4 WIRE.....	54
3.4.8	REMOTE START 3 PHASE 3 WIRE.....	55
3.4.9	REMOTE START 2 PHASE (L1, L2) 3 WIRE	56
3.4.10	REMOTE START 2 PHASE (L1, L3) 3 WIRE	57
3.4.11	REMOTE START SINGLE PHASE 2 WIRE	58
4	DESCRIPTION OF CONTROLS.....	59
4.1	CONTROL PUSH BUTTONS	60
4.2	MODULE DISPLAY.....	62
4.2.1	SINGLE LINE DIAGRAM (SLD).....	63
4.2.2	SPLASH SCREEN	64
4.2.3	BACKLIGHT	64
4.3	VIEWING THE INSTRUMENT PAGES.....	65
4.3.1	PAGE MENU ICONS	65
4.3.2	GENERAL PAGE NAVIGATION	66
4.3.3	HOME	68
4.3.4	ENGINE.....	69
4.3.5	GENERATOR.....	74
4.3.6	MAINS	75
4.3.7	ALARMS.....	76
4.3.8	ENGINE DTC (ECU ALARMS)	77
4.3.9	EVENT LOG.....	78
4.3.10	SCHEDULER	79
4.3.11	CONFIGURABLE CAN INSTRUMENTS	80
4.3.12	COMMUNICATIONS.....	81
4.3.13	ABOUT	82
4.3.14	ENGINE TIER 4 INFORMATION	83
5	OPERATION.....	86
5.1	QUICKSTART GUIDE.....	86
5.1.1	STARTING THE ENGINE	86
5.1.2	STOPPING THE ENGINE	87
5.2	STOP/RESET MODE	88
5.3	AUTOMATIC MODE	89
5.3.1	WAITING IN AUTO MODE.....	89
5.3.2	STARTING SEQUENCE	90
5.3.3	ENGINE RUNNING.....	91
5.3.4	STOPPING SEQUENCE.....	91
5.4	MANUAL/START MODE	92
5.4.1	WAITING IN MANUAL MODE.....	92
5.4.2	STARTING SEQUENCE	93
5.4.3	ENGINE RUNNING.....	94
5.4.4	STOPPING SEQUENCE.....	94
5.5	FAILSAFE MODE	95
5.6	SCHEDULER	95
5.6.1	STOP MODE	96
5.6.2	MANUAL MODE.....	96
5.6.3	AUTO MODE.....	96
5.7	ALTERNATIVE CONFIGURATIONS.....	97
6	PROTECTIONS	98

6.1	ALARMS	98
6.1.1	WARNING ALARMS	99
6.1.2	ELECTRICAL TRIP ALARMS	101
6.1.3	SHUTDOWN ALARMS	103
6.1.4	MAINTENANCE ALARMS	106
7	FRONT PANEL CONFIGURATION.....	107
7.1	FRONT PANEL EDITOR	108
7.1.1	FRONT PANEL EDITOR DISPLAY	108
7.1.2	ACCESSING THE FRONT PANEL EDITOR	109
7.1.3	ENTERING PIN	109
7.1.4	EDITING A PARAMETER	110
7.1.5	EXITING THE MAIN CONFIGURATION EDITOR	110
7.1.6	FRONT PANEL EDITOR PARAMETERS.....	111
8	COMMISSIONING	114
9	CAN INTERFACE SPECIFICATION (J1939-75).....	115
9.1	BROADCAST MESSAGES J1939-75	115
9.1.1	INSTRUMENTATION	116
9.1.2	DM1 - CONDITIONS ACTIVE DIAGNOSTIC TROUBLE CODES	132
10	FAULT FINDING	135
10.1	STARTING	135
10.2	LOADING	135
10.3	ALARMS	136
10.4	COMMUNICATIONS	136
10.5	INSTRUMENTS	137
10.6	MISCELLANEOUS	137
11	MAINTENANCE, SPARES, REPAIR AND SERVICING	138
11.1	PURCHASING ADDITIONAL CONNECTOR PLUGS FROM DSE.....	138
11.1.1	PACK OF PLUGS	138
11.1.2	INDIVIDUAL PLUGS	138
11.2	PURCHASING ADDITIONAL FIXING CLIPS FROM DSE	138
12	WARRANTY	139
13	DISPOSAL.....	139
13.1	WEEE (WASTE ELECTRICAL AND ELECTRONIC EQUIPMENT)	139

1 INTRODUCTION

This document details the installation and operation requirements of the DSEG4500 and DSEG4501 *Compact Single Genset Controller* and is part of the DSE *Genset*® range of products.

The manual forms part of the product and must be kept for the entire life of the product. If the product is passed or supplied to another party, ensure that this document is passed to them for reference purposes.

This is not a *controlled document*. DSE do not automatically inform on updates. Any future updates of this document are included on the DSE website at www.deepseaelectronics.com

The DSEG4xxx series is designed to provide differing levels of functionality across a common platform. This allows the generator OEM greater flexibility in the choice of controller to use for a specific application.

The DSEG45xx modules have been designed to allow the operator to start and stop the generator, and if required, transfer the load to the generator either manually or automatically. Additionally, the DSEG4500 automatically starts and stops the generator set depending upon the status of the mains (utility) supply.

The user also has the facility to view the system operating parameters via the text LCD display.

The DSEG45xx modules monitor the engine, indicating the operational status and fault conditions, automatically shutting down the engine and giving a true first up fault condition of an engine failure by the text LCD display.

The powerful ARM microprocessor contained within the module allows for incorporation of a range of complex features:

- *Icon based LCD display*
- *True RMS Voltage*
- *Current and Power monitoring*
- *USB Communications*
- *Engine parameter monitoring.*
- *Fully configurable inputs for use as alarms or a range of different functions.*
- *Engine ECU interface to electronic engines*



The DSE Configuration Suite PC Software allows alteration of selected timers, alarms, and operational sequences. Additionally, the module's integral front panel configuration editor allows adjustment of this information.

Access to critical operational sequences and timers for use by qualified engineers can be protected by a security code. Module access can also be protected by PIN code. Selected parameters can be changed from the module's front panel.

The module is housed in a robust plastic case suitable for panel mounting. Connections to the module are via locking plug and sockets.

1.1 CLARIFICATION OF NOTATION

Clarification of notation used within this publication.

 NOTE:	Highlights an essential element of a procedure to ensure correctness.
 CAUTION!	Indicates a procedure or practice, which, if not strictly observed, could result in damage or destruction of equipment.
 WARNING!	Indicates a procedure or practice, which could result in injury to personnel or loss of life if not followed correctly.

1.2 GLOSSARY OF TERMS

Term	Description
DSEG4xxx	All modules in the DSEG4xxx range.
DSEG4500 DSEG45xx	All modules in the DSEG45xx range.
DSEG4500	DSEG4500 module/controller
DSEG4501	DSEG4501 module/controller
AWG	American Wire Gauge A standardized system used in the United States (and some other countries) to denote the diameter of electrically conducting wires.
CAN	Controller Area Network Vehicle standard to allow digital devices to communicate to one another.
CDMA	Code Division Multiple Access. Cell phone access used in small number of areas including parts of the USA and Australia.
CT	Current Transformer An electrical device that takes a large AC current and scales it down by a fixed ratio to a smaller current.
DEF	Diesel Exhaust Fluid (AdBlue) A liquid used as a consumable in the SCR process to lower nitric oxide and nitrogen dioxide concentration in engine exhaust emissions.
DM1	Diagnostic Message 1 A DTC that is currently active on the engine ECU.
DM2	Diagnostic Message 2 A DTC that was previously active on the engine ECU and has been stored in the ECU's internal memory.
DPF	Diesel Particulate Filter A filter fitted to the exhaust of an engine to remove diesel particulate matter or soot from the exhaust gas.
DPTC	Diesel Particulate Temperature Controlled Filter A filter fitted to the exhaust of an engine to remove diesel particulate matter or soot from the exhaust gas which is temperature controlled.
DTC	Diagnostic Trouble Code The name for the entire fault code sent by an engine ECU.
ECU/ECM	Engine Control Unit/Management An electronic device that monitors engine parameters and regulates the fuelling.
FMI	Failure Mode Indicator A part of DTC that indicates the type of failure, e.g. high, low, open circuit etc.
HEST	High Exhaust System Temperature Initiates when DPF filter is full in conjunction with an extra fuel injector in the exhaust system to burn off accumulated diesel particulate matter or soot.

Continued over page...

Introduction

Term	Description
NFPA	National Fire Protection Association A U.S.-based nonprofit organization that develops and publishes codes and standards intended to minimize the risk and effects of fire and other hazards.
OC	Occurrence Count A part of DTC that indicates the number of times that failure has occurred.
PGN	Parameter Group Number A CAN address for a set of parameters that relate to the same topic and share the same transmission rate.
PIN	Personal Identification Number A PIN is a numeric code used to verify someone's identity.
PLC	Programmable Logic Controller A programmable digital device used to create logic for a specific purpose.
SCADA	Supervisory Control And Data Acquisition A system that operates with coded signals over communication channels to provide control and monitoring of remote equipment
SCR	Selective Catalytic Reduction A process that uses DEF with the aid of a catalyst to convert nitric oxide and nitrogen dioxide into nitrogen and water to reduce engine exhaust emission.
SPN	Suspect Parameter Number A part of DTC that indicates what the failure is, e.g. oil pressure, coolant temperature, turbo pressure etc.
UL	Underwriters Laboratories A global safety certification company that develops standards and conducts testing to ensure products meet specific safety requirements.

1.3 BIBLIOGRAPHY

This document refers to and is referred by the following DSE publications which are obtained from the DSE website: www.deepseaelectronics.com or by contacting DSE technical support: support@deepseaelectronics.com.

1.3.1 INSTALLATION INSTRUCTIONS

Installation instructions are supplied with the product in the box and are intended as a 'quick start' guide only.

DSE Part	Description
053-280	DSEG4500 & DSEG4501 Installation Instructions

1.3.2 MANUALS

Product manuals are obtained from the DSE website: www.deepseaelectronics.com or by contacting DSE technical support: support@deepseaelectronics.com.

DSE Part	Description
N/A	Gencomm (MODBUS protocol for DSE controllers)
057-004	Electronic Engines and DSE Controllers
057-151	DSE Configuration Suite PC Software Installation & Operation Manual
057-220	Options for Communications with DSE Controllers
057-378	DSEG4500 & DSEG4501 DSE Configuration Suite PC Software Manual

1.3.3 TRAINING GUIDES

Training guides are provided as 'hand-out' sheets on specific subjects during training sessions and contain specific information regarding to that subject.

DSE Part	Description
056-005	Using CTs With DSE Products
056-006	Introduction to Data Communications
056-010	Overcurrent Protection
056-022	Switchgear Control
056-023	Adding Development Engine Files
056-026	kW, kvar, kVA and pf.
056-028	Smoke Limiting and Idle Speed
056-030	Module PIN Codes
056-055	Alternative Configurations
056-069	Firmware Update
056-075	Adding New Language Files
056-076	Gencomm Alarms
056-079	Gencomm Status
056-080	Modbus
056-081	Screen Heaters
056-082	DSE PLC Logic Example
056-091	Equipotential Earth Bonding
056-092	Recommended Practices for Wiring Resistive Sensors
056-095	Remote Start Input Functions
056-097	USB Earth Loops and Isolation

1.3.4 THIRD PARTY DOCUMENTS

The following third party documents are also referred to:

Reference	Description
ISBN 1-55937-879-4	IEEE Std C37.2-1996 IEEE Standard Electrical Power System Device Function Numbers and Contact Designations. Institute of Electrical and Electronics Engineers Inc
ISBN 0-7506-1147-2	Diesel Generator Handbook. L.L.J. Mahon
ISBN 0-9625949-3-8	On-Site Power Generation. EGSA Education Committee.

2 SPECIFICATION

2.1 PART NUMBERING

At the time of this document production, there are two variants of this product.

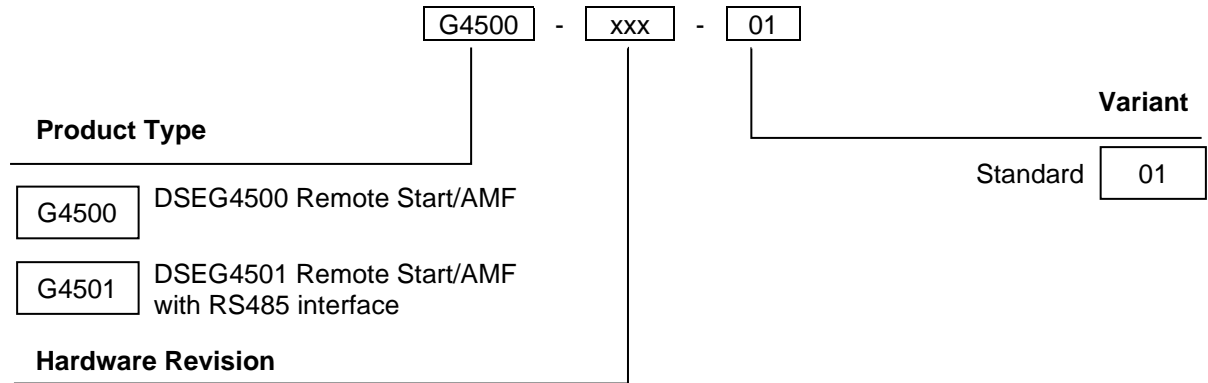

2.2 OPERATING TEMPERATURE

Module	Specification
Standard Variants	-22 °F to +158 °F (-30 °C to +70 °C)

2.3 REQUIREMENTS FOR UL

 **WARNING!** More than one live circuit exists, refer to section entitled *Typical Schematic Diagram* elsewhere in this document

Description	Specification
Screw Terminal Tightening Torque	4.5 lb-in (0.5 Nm)
Conductors	<ul style="list-style-type: none"> Terminals suitable for connection of conductor size 13 AWG to 20 AWG (0.5 mm² to 2.5 mm²). Conductor protection must be provided in accordance with NFPA 70, Article 240. Low voltage circuits (35 V or less) must be supplied from the engine starting battery or an isolated secondary circuit. The communication, sensor, and/or battery derived circuit conductors shall be separated and secured to maintain at least ¼" (6 mm) separation from the generator and mains connected circuit conductors unless all conductors are rated 600 V or greater. Use min. 90 °C Copper Conductors Only.
Current Inputs	From Listed or R/C (XODW2.8) current transformers.
Communication Circuits	Must be connected to communication circuits of UL Listed equipment.
Output Pilot Duty	0.5 A
Mounting	<ul style="list-style-type: none"> Suitable for use on a flat surface of a Type 1 Enclosure rating with surrounding air temperature -22 °F to +158 °F (-30 °C to +70 °C). Suitable for pollution degree 3 environments when voltage sensing inputs do not exceed 300 V. When used to monitor voltages over 300 V device to be installed in an unventilated or filtered ventilation enclosure to maintain a pollution degree 2 environment.
Operating Temperature	-22 °F to +158 °F (-30 °C to +70 °C)
Storage Temperature	-40 °F to +176 °F (-40 °C to +80 °C)

2.4 TERMINAL SPECIFICATION

Description	Specification	
Connection Type	Two part connector. Male part fitted to module Female part supplied in module packing case - Screw terminal, rising clamp, no internal spring.	 Example showing cable entry and screw terminals of a 10 way connector
Minimum Cable Size	0.5 mm ² (AWG 20)	
Maximum Cable Size	2.5 mm ² (AWG 13)	
Tightening Torque	4.5 lb-in (0.5 Nm)	
Wire Strip Length	7 mm (9/32")	

2.5 POWER SUPPLY REQUIREMENTS

Description	Specification
Minimum Supply Voltage	8 V continuous, 5 V for up to 1 minute.
Start Dropouts	Able to survive 0 V for greater than 50 ms providing the supply was at least was greater than 10 V for 5 seconds before the dropout and recovers to greater than 10 V afterwards.
Maximum Supply Voltage	35 V continuous (60 V protection)
Reverse Polarity Protection	-35 V continuous
Maximum Operating Current	200 mA at 12 V 120 mA at 24 V
Maximum Standby Current	65 mA at 12 V 35 mA at 24 V
Maximum Current When In Sleep Mode	95 mA at 12 V 55 mA at 24 V
Maximum Current When In Deep Sleep Mode	Less than 10 μ A at 12 V Less than 10 μ A at 24 V
Typical Power	1 W to 3 W
Typical Power (Controller On, Heater On)	No heater fitted or available

2.5.1 MODULE SUPPLY INSTRUMENTATION DISPLAY

Description	Specification
Range	0 V to 70 V DC (Maximum continuous operating voltage of 35 V DC)
Resolution	0.1 V
Accuracy	1 % full scale (\pm 0.35 V)

2.6 VOLTAGE & FREQUENCY SENSING

Description	Specification
Measurement Type	True RMS conversion
Harmonics	Up to 21 st or better
Input Impedance	450 k Ω phase to neutral
Phase To Neutral	15 V (minimum required for sensing frequency) to 415 V AC (absolute maximum) Suitable for 345 V AC nominal (\pm 20 % for under/overvoltage detection)
Phase To Phase	25 V (minimum required for sensing frequency) to 720 V AC (absolute maximum) Suitable for 600 V AC nominal (\pm 20 % for under/overvoltage detection)
Common Mode Offset From Earth	100 V AC (max)
Resolution	1 V AC phase to neutral 2 V AC phase to phase
Accuracy	\pm 1 % of full scale phase to neutral \pm 2 % of full scale phase to phase
Minimum Frequency	3.5 Hz
Maximum Frequency	75.0 Hz
Frequency Resolution	0.1 Hz
Frequency Accuracy	\pm 0.05 Hz

2.7 CURRENT SENSING

Description	Specification
Measurement Type	True RMS conversion
Harmonics	Up to 21 st
Nominal CT Secondary Rating	1 A and 5 A (Software derived not Hardware)
Maximum Continuous Current	5 A
Absolute Maximum Overload	15 A for 1 second
Burden	0.25 VA (0.01 Ω current shunts)
Resolution	25 mA
Accuracy	±1 % of Nominal (excluding CT error)

2.7.1 VA RATING OF THE CTS

NOTE: Details for 4 mm² cables are shown for reference only. The connectors on the DSE modules are only suitable for cables up to 2.5 mm².

The VA burden of the module on the CTs is 0.25 VA. However, depending upon the type and length of cabling between the CTs and the module, CTs with a greater VA rating than the module are required.

Estimate the distance between the CTs and the measuring module and cross-reference it against the chart opposite to find the VA burden of the cable itself.

If the CTs are fitted within the alternator top box, connect the star point (common) of the CTs to system ground (earth) as close as possible to the CTs. This minimizes the length of cable used to connect the CTs to the DSE module.

Example:

If 1.5 mm² cable is used and the distance from the CT to the measuring module is 20 m, then the burden of the cable alone is approximately 15 VA. As the burden of the DSE controller is 0.25 VA, then a CT with a rating of at least 15 VA + 0.25 VA = 15.25 VA

must be used. If 2.5 mm² cables are used over the same distance of 20 m, then the burden of the cable on the CT is approximately 7 VA. CT's required in this instance is at least 7.25 VA (7 + 0.25).

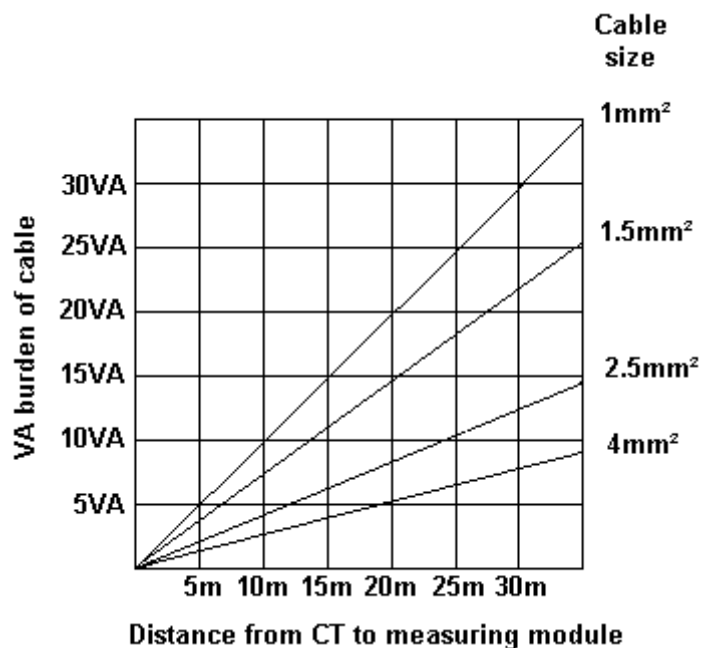

2.7.2 CT POLARITY

NOTE: Take care to ensure correct polarity of the CT primary as shown above. If in doubt, check with the CT supplier.

Take care to ensure the correct polarity of the CTs. Incorrect CT orientation leads to negative kW readings when the set is supplying power. Take note that paper stick-on labels on CTs that show the orientation are often incorrectly placed on the CT. It is more reliable to use the labelling in the case moulding as an indicator to orientation (if available).

To verify correct phase orientation, run the generator as a standalone unit (not connected to the mains or other generators). Apply a load of approximately 10% of the generator's rated capacity.

- For three-phase systems, ensure the DSE module displays positive kW readings on all three individual phases.
- For single-phase systems, only the active phase needs to show a positive kW reading.

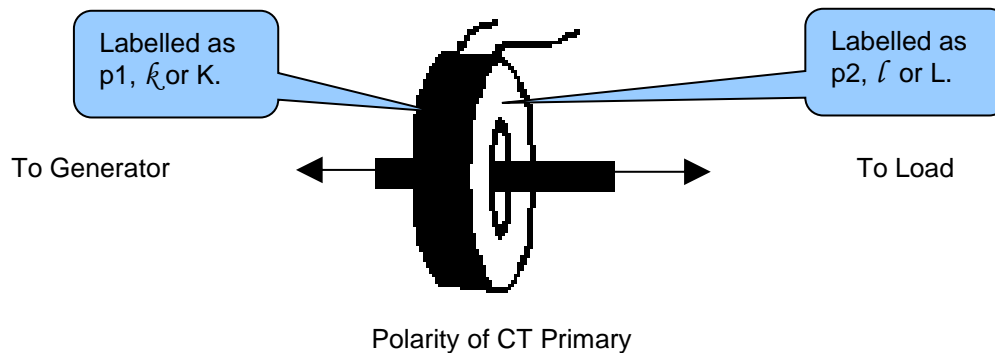

2.7.3 CT PHASING

Take particular care that the CTs are connected to the correct phases. For instance, ensure that the CT on phase 1 is connected to the terminal on the DSE module intended for connection to the CT for phase 1.

Additionally, ensure that the voltage sensing for phase 1 is connected to generator phase 1. Incorrect connection of the phases as described above results in incorrect power factor (PF) measurements, which in turn results in incorrect kW measurements.

One way to check for this is to make use of a single-phase load. Place the load on each phase in turn, run the generator and ensure the kW value appears in the correct phase. For instance, if the load is connected to phase 3, ensure the kW figure appears in phase 3 display and not in the display for phase 1 or 2.

2.7.4 CT CLASS

Ensure the correct CT type is chosen. For instance, if the DSE module is providing overcurrent protection, ensure the CT is capable of measuring the overload level required to protect against, and at the accuracy level required.

For instance, this may mean fitting a protection class CT (P15 type) to maintain high accuracy while the CT is measuring overload currents.

Conversely, if the DSE module is using the CT for instrumentation only (current protection is disabled or not fitted to the controller), then measurement class CTs can be used. Again, bear in mind the accuracy required. The DSE module is accurate to better than 1% of the full-scale current reading. To maintain this accuracy, fit a Class 0.5 or Class 1 CT.

Check with the CT manufacturer for further advice on selecting CTs.

2.8 INPUTS

2.8.1 DIGITAL INPUTS

Description	Specification
Number	4 configurable digital inputs (7 when <i>Analogue Inputs</i> are configured as digital inputs)
Arrangement	Contact between terminal and ground
Low Level Threshold	3.2 V minimum
High Level Threshold	8.1 V maximum
Maximum Input Voltage	+60 V DC with respect to module DC supply negative
Minimum Input Voltage	-24 V DC with respect to module DC supply negative
Contact Wetting Current	5 mA typical
Open Circuit Voltage	12 V typical

2.8.2 ANALOGUE INPUTS

2.8.2.1 ANALOGUE INPUT A

Description	Specification
Input Type	Flexible: Configured for <i>Oil Sensor</i> in the DSE default configuration. Flexible Options: Not used, Coolant Level Sensor, Digital Input, Flexible Analogue & Oil Sensor
Flexible Input Selection	Pressure Sensor Percentage Sensor Temperature Sensor
Flexible Measured Quantity	Resistive Voltage Current

Resistive Configuration

Description	Specification
Measurement Type	Resistance measurement by internal ratiometric system
Arrangement	Differential resistance measurement input
Measurement Current	15 mA \pm 10% Nominal
Full Scale	3 k Ω
Over Range / Fail	5 k Ω
Resolution	\pm 1% of Value
Accuracy	\pm 2% of Value \pm 2 Counts excluding sensor error
Max Common Mode Voltage	\pm 2 V
Display Range	Configurable by PC Software

0 V to 10 V Configuration

Description	Specification
Full Scale	0 V to 10 V
Resolution	1% of full scale
Accuracy	±2% of full-scale voltage (±0.2 V) excluding sensor error
Max Common Mode Voltage	±2 V
Display Range	Configurable by PC Software

4 mA to 20 mA Configuration

Description	Specification
Full Scale	0 mA to 20 mA
Resolution	2% of full scale
Accuracy	±2% of full-scale current (±0.4 mA) excluding sensor error
Max Common Mode Voltage	±2 V
Display Range	Configurable by PC Software

2.8.2.2 ANALOGUE INPUT B

Description	Specification
Input Type	<i>Coolant Temperature Sensor or Coolant Level Sensor or Digital Input or Not Used</i>
Measurement Type	Resistance measurement by measuring voltage across sensor with a fixed current applied
Arrangement	Differential resistance measurement input
Measurement Current	10 mA ±10%
Full Scale	3 kΩ
Over Range / Fail	5 kΩ
Resolution	±1 % of value
Accuracy	±2 % of value ±2 Counts excluding sensor error
Max Common Mode Voltage	±2 V
Display Range	Configurable by PC Software

2.8.2.3 ANALOGUE INPUT C

Description	Specification
Input Type	Flexible: Configured for <i>Fuel Level Sensor</i> in the DSE default configuration. Flexible Options: <i>Not Used, Coolant Level Sensor, Digital Input, Flexible Analogue & Fuel Level</i>
Flexible Input Selection	Pressure Sensor, Percentage Sensor or Temperature Sensor
Measurement Type	Resistance measurement by measuring voltage across sensor with a fixed current applied
Arrangement	Differential resistance measurement input
Measurement Current	8.5 mA \pm 10 %
Full Scale	3 k Ω
Over Range / Fail	5 k Ω
Resolution	\pm 1 % of value
Accuracy	\pm 2% of value \pm 2 Counts excluding sensor error
Max Common Mode Voltage	\pm 2 V
Display Range	Configurable by PC Software

2.8.3 CHARGE FAIL INPUT

The charge fail input is a combined input and output. Whenever the generator is required to run, the terminal provides excitation current to the charge alternator field winding. When the charge alternator is correctly charging the battery, the voltage of the terminal is close to the plant battery supply voltage. In a failed charge situation, the voltage of this terminal is pulled down to a low voltage. It is this drop in voltage that triggers the *Charge Failure* alarm. The level at which this operates and whether this triggers a warning or shutdown alarm is configurable using the DSE Configuration Suite Software.

Description	Specification
Minimum Voltage	0 V
Maximum Voltage	35 V
Resolution	0.2 V
Accuracy	\pm 1 % of full scale
Excitation	Active circuit constant power output
Output Power	2.5 W nominal at 12 V and 24 V
Current At 12V	210 mA
Current At 24V	105 mA

2.8.4 MAGNETIC PICK-UP

Magnetic Pickup devices can often be 'shared' between two or more devices. For example, one device can often supply the signal to both the DSE module and the engine governor. The possibility of this depends upon the amount of current that the magnetic pickup can supply.

Description	Specification
Type	Differential input
Minimum Voltage	0.5 V RMS
Maximum Voltage	70 V RMS
Max Common Mode Voltage	\pm 2 V peak
Minimum Frequency	5 Hz
Maximum Frequency	10,000 Hz
Resolution	6.25 rpm
Accuracy	\pm 25 rpm
Flywheel Teeth	10 to 500

2.9 OUTPUTS

2.9.1 DC OUTPUTS A & B (FUEL & START)

Description	Specification
Type	Normally used as <i>Fuel & Start</i> outputs. Fully configurable for other purposes if the module is configured to control an electronic engine, supplied from DC supply terminal 2.
Rating	0.5 A resistance continuous at module supply.

2.9.2 DC OUTPUTS C, D, E & F

DC Output Configuration

Description	Specification
Type	Fully configurable, supplied from DC supply terminal 2.
Rating	0.5 A resistance continuous at module supply.

5 V Sensor Supply Output Configuration (AUX)

Description	Specification
Type	Supplied from DC supply terminal 2.
Rating	20 mA resistive at 5 V.

2.10 COMMUNICATION PORTS

 **NOTE: All communication ports can be used at the same time.**

Description	Specification
USB Configuration Port	Type B USB 2.0 For connection to PC running DSE Configuration Suite Max distance 5 m (16 feet)
CAN Port	<div style="border: 1px solid black; padding: 5px; margin-bottom: 5px;">  NOTE: For additional length, the DSE124 CANbus Extender is available. For more information, refer to DSE Publication: 057-116 DSE124 CAN Extender Operator Manual </div> Engine CAN Port Standard implementation of 'Slow mode', up to 250 kb/s Non-Isolated Internal Termination provided (120 Ω) Max distance 40 m (133 feet)

2.11 COMMUNICATION PORT USAGE

2.11.1 USB CONFIGURATION PORT (PC CONFIGURATION)

NOTE: DSE stock 2 m (6.5 feet) USB type A to type B cable, DSE Part Number: 016-125. Alternatively, they are purchased from any PC or IT store.

NOTE: The DC supply must be connected to the module for configuration by PC.

NOTE: For further details of module configuration, refer to DSE Publication: 057-378 *DSEG4500 & DSEG4501 Configuration Suite Software Manual*.

The USB port is provided to give a simple means of connection between a PC and the controller. Using the DSE Configuration Suite Software, the operator is then able to control the module, starting or stopping the engine, selecting operating modes, etc.

Additionally, the various operating parameters (such as coolant temperature, oil pressure, etc.) of the engine are available to be viewed or changed.

To connect a module to a PC by USB, the following items are required:

- DSEG4500 Module



- DSE Configuration Suite PC Software
(Available from www.deepseaelectronics.com).

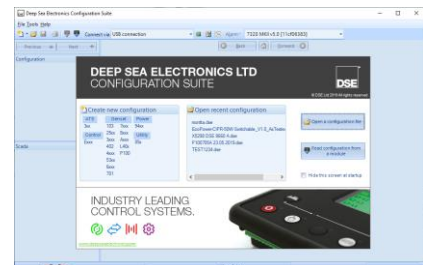

- USB cable Type A to Type B.
(This is the same cable as often used between a PC and a USB printer)
DSE stock this cable:
PC Configuration interface lead (USB type A – type B) DSE Part No 016-125



2.11.2 CAN PORT (J1939)

NOTE: For further details of module configuration, refer to DSE Publication: *057-378 DSEG4500 & DSEG4501 Configuration Suite Software Manual*.

NOTE: For further details on connection to electronic engines, refer to DSE Publication: *057-004 Electronic Engines And DSE Wiring*

NOTE: Screened 120 Ω impedance cable specified for use with CAN must be used for the CAN link.
DSE stock and supply Belden cable 9841 which is a high quality 120 Ω impedance cable suitable for CAN use (DSE part number 016-030)

NOTE: For additional length, the DSE124 CANbus Extender is available. For more information, refer to DSE Publication: *057-116 DSE124 CAN Extender Operator Manual*

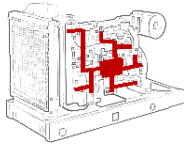

The modules are fitted with a CAN interface as standard and are capable of receiving engine data from engine ECU/ECMs compliant with the CAN J1939 standard.

ECU/ECMs monitor the engine's operating parameters such as speed, oil pressure, coolant temperature (among others) to closely monitor and control the engine. The industry standard communications interface (CAN) transports data gathered by the engine's ECU/ECM using the J1939 protocol. This allows engine controllers such as DSE to access these engine parameters with no physical connection to the sensor device.

The *ECU Port* is used for point-to-point cable connection of more than one device and allows for connection to CAN Scanner, PLC, and CAN controllers (to name just a few devices). The operator is then able to view the various operating parameters.

2.11.2.1 J1939-75

Note: For further details of module configuration, refer to DSE Publication: *057-378 DSEG4500 & DSEG4501 Configuration Suite Software Manual*.

NOTE: For further details of CAN communication, see the section entitled *CAN Interface Specification (J1939-75)* elsewhere in this document.

When the J1939-75 is enabled in the module's configuration, the module's AC measurements and alarms are sent onto the CANbus using the *ECU Port* to be received by an external monitoring device. There are two check boxes to enable each of the two parts of the interface as shown below, AC measurement and AC related alarms. The module AC alarms are translated into J1939 DM1 diagnostic messages. There are no additional display screens visible on the module when these options are selected. The default CAN source address for additional J1939-75 messages is 44 however this may be changed by the generator supplier.

Miscellaneous Options

J1939-75 Instrumentation Enable	<input checked="" type="checkbox"/>
J1939-75 Alarms Enable	<input checked="" type="checkbox"/>
CAN source address (instrumentation)	44

2.12 ADDING AN EXTERNAL SOUNDER

If an external alarm or indicator be required, this is achievable by using the DSE Configuration Suite PC software to configure an auxiliary output for *Audible Alarm*, and by configuring an auxiliary input for *Alarm Mute*.

The audible alarm output activates and de-activates at the same time as the module's internal sounder. The *Audible Alarm* output de-activates when the *Alarm Mute* input activates or after the *Audible Alarm Duration* time has ceased.

Example of configuration to achieve external sounder with external alarm mute button or an automatic mute after 1 minute and 30 seconds:

The image shows four configuration panels from the DSE Configuration Suite software:

- Relay Outputs (DC Supply Out):** Shows Output E configured with Source 'Audible Alarm' and Polarity 'Energise'.
- Digital Input A:** Shows Function 'Alarm Mute', Polarity 'Close to Activate', and an Activation Delay of 0s.
- Module Options:** A list of options with checkboxes and dropdown menus. 'Show Load Switching Icons' is checked. Other options include Lamp Test at Power-Up, Protected Start Mode, ECU Override During Protected Start, Event Log In Hours Run, Display SPN Strings, Enable Fast Loading, Maintenance Pin Protected Enable, Enable Cool Down in Stop Mode, Power Up in Mode (set to Stop), All Warnings are Latched, Enhanced Tier IV Home Screen, Limit Audible Alarm Duration, Enable Text Mode, Oil Pressure Display Option (set to Bar Graph), Coolant Temperature Display Option (set to Bar Graph 80-175°C), and Fuel Level Display Option (set to Bar Graph).
- Module Timers:** Shows sliders for Backlight Power Save Mode Delay (1m), Power Save Mode Delay (1m), Deep Sleep Delay (1m 30s), Page Delay (5m), and Audible Alarm (20s).

2.13 ACCUMULATED INSTRUMENTATION

 **NOTE: When an accumulated instrumentation value exceeds the maximum number as listed below, the value is reset and begins counting from zero again.**

The number of logged *Engine Hours* and *Number of Starts* can be set/reset using the DSE Configuration Suite PC software. Depending upon module configuration, this may have been PIN number locked by the generator supplier.

Description	Specification
Engine Hours Run	Maximum 99999 hrs 59 minutes (Approximately 11yrs 4 months)
Number of Starts	1,000,000 (1 Million)
Accumulated Power	999999 kWh / kvarh / kVAh

2.14 DIMENSIONS AND MOUNTING

2.14.1 DIMENSIONS

142 mm x 118 mm x 48 mm
(5.6 " x 4.6" x 1.9 ")

2.14.2 PANEL CUTOUT

118 mm x 92 mm
(4.6 " x 3.6 ")

2.14.3 WEIGHT

0.240 kg
(0.52 lb)

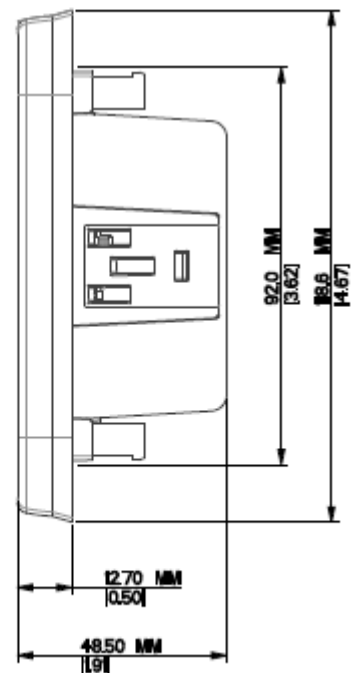
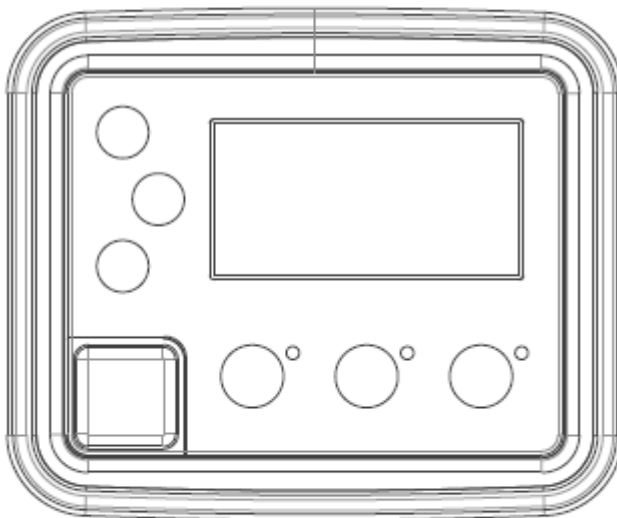
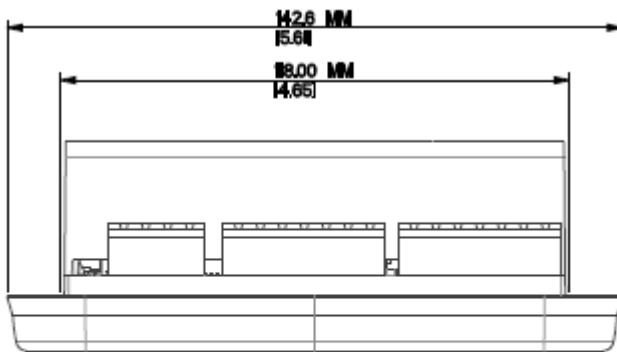

2.14.4 FIXING CLIPS

NOTE: In conditions of excessive vibration, mount the module on suitable anti-vibration mountings.

The module is held into the panel fascia using the supplied fixing clips.

- Withdraw the fixing clip screw (turn anticlockwise) until only the pointed end is protruding from the clip.
- Insert the module into the panel fascia.
- Insert the three 'prongs' of the fixing clip into the slots in the side of the module case.
- Pull the fixing clip backwards (towards the back of the module) ensuring all three prongs of the clip are inside their allotted slots.
- Turn the fixing clip screws clockwise until they contact the panel fascia.
- Turn the screw a quarter of a turn to secure the module into the panel fascia. Care must be taken not to over tighten the fixing clip screws.

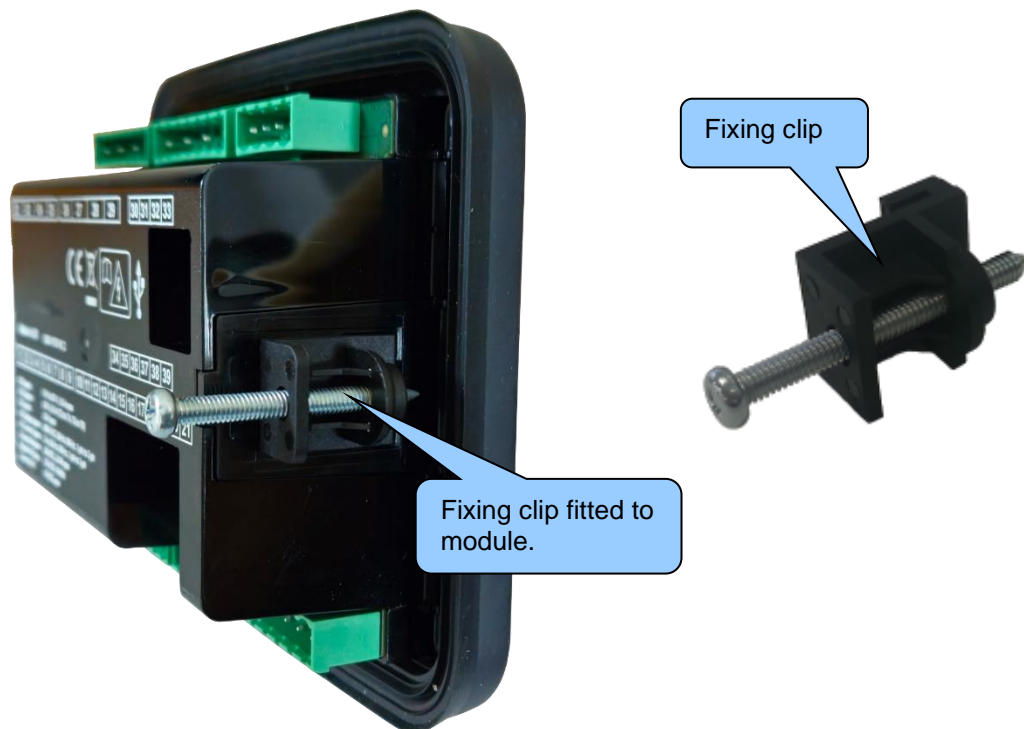

2.15 APPLICABLE STANDARDS

Standard	Description
BS EN 60068-2-1 (Minimum temperature)	-30 °C (-22 °F)
BS EN 60068-2-2 (Maximum temperature)	+70 °C (158 °F)
BS EN 60068-2-6 (Vibration)	Ten sweeps in each of three major axes 5 Hz to 8 Hz at ± 7.5 mm 8 Hz to 500 Hz at 2 gn
BS EN 60068-2-27 (Shock)	Three shocks in each of three major axes 15 gn in 11 ms
BS EN 60068-2-30 (Damp heat cyclic)	20°C to 55 °C (68 °F to 131 °F) at 95% relative humidity for 48 hours
BS EN 60068-2-78 (Damp heat static)	40 °C (104 °F) at 95% relative humidity for 48 hours
BS EN 61000-6-2 (Electro-magnetic Compatibility)	EMC Generic Immunity Standard (Industrial)
BS EN 61000-6-4 (Electro-magnetic Compatibility)	EMC Generic Emission Standard (Industrial)
BS-EN-61010 (Electrical Safety)	Safety requirements for electrical equipment for measurement, control and laboratory use.
BS EN 60529 (Degrees of protection provided by enclosures)	IP65 (front of module when installed into the control panel with the optional sealing gasket) IP42 (front of module when installed into the control panel WITHOUT being sealed to the panel)
UL508 NEMA rating (Approximate)	12 (Front of module when installed into the control panel with the optional sealing gasket). 2 (Front of module when installed into the control panel WITHOUT being sealed to the panel)
IEEE C37.2 (Standard Electrical Power System Device Function Numbers and Contact Designations)	Under the scope of IEEE 37.2, function numbers can also be used to represent functions in microprocessor devices and software programs. The controller is device number 11L-8000 (Multifunction device protecting Line (generator) –module). As the module is configurable by the generator OEM, the functions covered by the module vary. Depending on module configuration, the device numbers included within the module could be: 2 – Time Delay Starting Or Closing Relay 3 – Checking Or Interlocking Relay 5 – Stopping Device 6 – Starting Circuit Breaker 8 – Control Power Disconnecting Device 10 – Unit Sequence Switch 11 – Multifunction Device 12 – Overspeed Device 14 – Underspeed Device

Continued over the page..

Specification

Standard	Description
IEEE C37.2 (Standard Electrical Power System Device Function Numbers and Contact Designations)	Continued... 26 – Apparatus Thermal Device 27AC – AC Undervoltage Relay 27DC – DC Undervoltage Relay 29 – Isolating Contactor Or Switch 30 – Annunciator Relay 31 – Separate Excitation Device 42 – Running Circuit Breaker 50 – Instantaneous Overcurrent Relay 52 – AC Circuit Breaker 53 – Exciter Or DC Generator Relay 54 – Turning Gear Engaging Device 59AC – AC Overvoltage Relay 59DC – DC Overvoltage Relay 62 – Time Delay Stopping Or Opening Relay 63 – Pressure Switch 71 – Level Switch 74 – Alarm Relay 81 – Frequency Relay 83 – Automatic Selective Control Or Transfer Relay 86 – Lockout Relay

In line with our policy of continual development, Deep Sea Electronics, reserve the right to change specification without notice.

2.15.1 ENCLOSURE CLASSIFICATIONS

2.15.1.1 IP CLASSIFICATIONS

The modules specification under BS EN 60529 Degrees of protection provided by enclosures.

IP65 (Front of module when module is installed into the control panel with the optional sealing gasket).		IP42 (front of module when module is installed into the control panel WITHOUT being sealed to the panel)	
First Digit		Second Digit	
Protection against contact and ingress of solid objects		Protection against ingress of water	
0	No protection	0	No protection
1	Protected against ingress solid objects with a diameter of more than 50 mm. No protection against deliberate access, e.g. with a hand, but large surfaces of the body are prevented from approach.	1	Protection against dripping water falling vertically. No harmful effect must be produced (vertically falling drops).
2	Protected against penetration by solid objects with a diameter of more than 12 mm. Fingers or similar objects prevented from approach.	2	Protection against dripping water falling vertically. There must be no harmful effect when the equipment (enclosure) is tilted at an angle up to 15° from its normal position (drops falling at an angle).
3	Protected against ingress of solid objects with a diameter of more than 2.5 mm. Tools, wires etc. with a thickness of more than 2.5 mm are prevented from approach.	3	Protection against water falling at any angle up to 60° from the vertical. There must be no harmful effect (spray water).
4	Protected against ingress of solid objects with a diameter of more than 1 mm. Tools, wires etc. with a thickness of more than 1 mm are prevented from approach.	4	Protection against water splashed against the equipment (enclosure) from any direction. There must be no harmful effect (splashing water).
5	Protected against harmful dust deposits. Ingress of dust is not totally prevented but the dust must not enter in sufficient quantity to interface with satisfactory operation of the equipment. Complete protection against contact.	5	Protection against water projected from a nozzle against the equipment (enclosure) from any direction. There must be no harmful effect (water jet).
6	Protection against ingress of dust (dust tight). Complete protection against contact.	6	Protection against heavy seas or powerful water jets. Water must not enter the equipment (enclosure) in harmful quantities (splashing over).

2.15.1.2 NEMA CLASSIFICATIONS

 **NOTE: There is no direct equivalence between IP / NEMA ratings. IP figures shown are approximate only.**

12 (Front of module when module is installed into the control panel with the optional sealing gasket).		2 (Front of module when module is installed into the control panel WITHOUT being sealed to the panel)	
1 IP30	Provides a degree of protection against contact with the enclosure equipment and against a limited amount of falling dirt.		
2 IP31	Provides a degree of protection against limited amounts of falling water and dirt.		
3 IP64	Provides a degree of protection against windblown dust, rain and sleet; undamaged by the formation of ice on the enclosure.		
3R IP32	Provides a degree of protection against rain and sleet; undamaged by the formation of ice on the enclosure.		
4 (X) IP66	Provides a degree of protection against splashing water, windblown dust and rain, hose directed water; undamaged by the formation of ice on the enclosure. (Resist corrosion).		
12/12K IP65	Provides a degree of protection against dust, falling dirt and dripping noncorrosive liquids.		
13 IP65	Provides a degree of protection against dust and spraying of water, oil and non-corrosive coolants.		

3 INSTALLATION

The module is designed to be mounted on the panel fascia. For dimension and mounting details, see the section entitled *Dimension and Mounting* elsewhere in this document.

3.1 USER CONNECTIONS

NOTE: Availability of some terminals depends upon module version. Full details are given in the section entitled *Terminal Description* elsewhere in this manual.

To aid user connection, icons are used on the rear of the module to help identify terminal functions. An example of this is shown below.

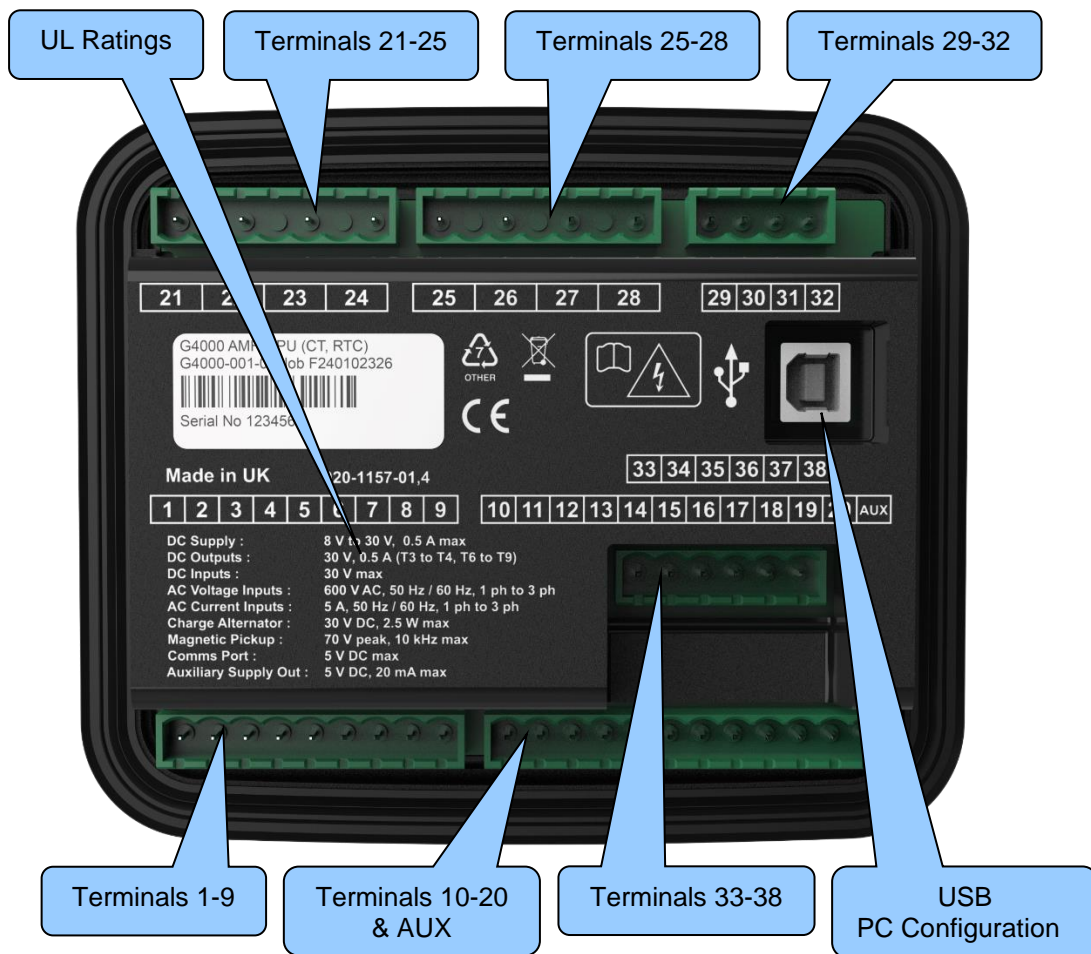

3.2 CONNECTION DESCRIPTIONS

3.2.1 DC SUPPLY, DC OUTPUTS & CHARGE FAIL INPUT

▲ NOTE: When the module is configured for operation with an electronic engine, *Fuel* and *Start* output requirements may be different. For further details on connection to electronic engines, refer to DSE Publication: *057-004 Electronic Engines And DSE Wiring*

▲ NOTE: For further details of module configuration, refer to DSE Publication: *057-378 DSEG4500 & DSEG4501 Configuration Suite Software Manual.*

Pin No	Description	Cable Size	Notes
1	DC Plant Supply Input (Negative)	2.5 mm ² AWG 13	Connect to ground where applicable.
2	DC Plant Supply Input (Positive)	2.5 mm ² AWG 13	Supplies the module and DC Outputs A, B, C, D, E & F
3	DC Output A (FUEL)	2.5 mm ² AWG 13	0.5 A resistance continuous at module supply.
4	DC Output B (START)	2.5 mm ² AWG 13	0.5 A resistance continuous at module supply.
5	Charge Fail / Excite	2.5mm ² AWG 13	Do not connect to ground (battery negative). If charge alternator is not fitted, leave this terminal disconnected.
6	DC Output C	1.0mm ² AWG 18	0.5 A resistance continuous at module supply.
7	DC Output D	1.0mm ² AWG 18	0.5 A resistance continuous at module supply.
8	DC Output E	1.0mm ² AWG 18	0.5 A resistance continuous at module supply.
9	DC Output F	1.0mm ² AWG 18	0.5 A resistance continuous at module supply.

3.2.2 ANALOGUE SENSOR INPUTS

▲ NOTE: For further details of module configuration, refer to DSE Publication: *057-378 DSEG4500 & DSEG4501 Configuration Suite Software Manual.*

▲ NOTE: It is VERY important that terminal 10 (sensor common) is connected to an earth point on the ENGINE BLOCK, not within the control panel, and must be a sound electrical connection to the sensor bodies. This connection **MUST NOT** be used to provide an earth connection for other terminals or devices. The simplest way to achieve this is to run a **SEPARATE** earth connection from the system earth star point, to terminal 10 directly, and not use this earth for other connections.

▲ NOTE: If PTFE insulating tape is used on the sensor thread when using earth return sensors, ensure not to insulate the entire thread, as this prevents the sensor body from being earthed via the engine block.

Pin No	Description	Cable Size	Notes
10	Sensor Common Return	0.5 mm ² AWG 20	Ground Return Feed For Sensors
11	Analogue Sensor Input A	0.5 mm ² AWG 20	Connect To Oil Pressure Sensor
12	Analogue Sensor Input B	0.5mm ² AWG 20	Connect To Coolant Temperature Sensor
13	Analogue Sensor Input C	0.5 mm ² AWG 20	Connect To Fuel Level Sensor or a Flexible Sensor

3.2.3 CONFIGURABLE DIGITAL INPUTS & CAN

NOTE: For further details of module configuration, refer to DSE Publication: *057-378 DSEG4500 & DSEG4501 Configuration Suite Software Manual.*

NOTE: For further details on connection to electronic engines, refer to DSE Publication: *057-004 Electronic Engines And DSE Wiring*

NOTE: Screened 120 Ω impedance cable specified for use with CAN must be used for the CAN link.
 DSE stock and supply Belden cable 9841 which is a high quality 120 Ω impedance cable suitable for CAN use (DSE part number 016-030)

Pin No	Description	Cable Size	Notes
14	Configurable Digital Input A	0.5mm ² AWG 20	Switch to negative
15	Configurable Digital Input B	0.5mm ² AWG 20	Switch to negative
16	Configurable Digital Input C	0.5mm ² AWG 20	Switch to negative
17	Configurable Digital Input D	0.5mm ² AWG 20	Switch to negative
18	CAN Port H	0.5mm ² AWG 20	Use only 120 Ω CAN approved cable
19	CAN Port L	0.5mm ² AWG 20	Use only 120 Ω CAN approved cable
20	CAN Port Screen	Shield	Use only 120 Ω CAN approved cable
AUX	5 V Reference Output	0.5 mm ² AWG 20	20 mA rated from module supply.

3.2.4 GENERATOR & MAINS VOLTAGE & FREQUENCY SENSING

▲ NOTE: The below table describes connections to a three phase, four wire alternator. For alternative wiring topologies, see the section entitled *Alternate Topology Wiring Diagrams* elsewhere in this document.

Pin No	Description	Cable Size	Notes
21	Generator L1 (U) Voltage Sensing	1.0 mm ² AWG 18	Connect to Generator L1 (U) output (AC) (Recommend 2 A fuse)
22	Generator L2 (V) Voltage Sensing	1.0 mm ² AWG 18	Connect to Generator L2 (V) output (AC) (Recommend 2 A fuse)
23	Generator L3 (W) Voltage Sensing	1.0 mm ² AWG 18	Connect to Generator L3 (W) output (AC) (Recommend 2 A fuse)
24	Generator Neutral (N) Input	1.0 mm ² AWG 18	Connect to Generator Neutral terminal (AC)
25	Mains L1 (R) Voltage Monitoring	1.0mm ² AWG 18	Connect to Mains L1 (R) output (AC) (Recommend 2A fuse)
26	Mains L2 (S) Voltage Monitoring	1.0mm ² AWG 18	Connect to Mains L2 (S) output (AC) (Recommend 2A fuse)
27	Mains L3 (T) Voltage Monitoring	1.0mm ² AWG 18	Connect to Mains L3 (T) output (AC) (Recommend 2A fuse)
28	Mains Neutral (N) Input	1.0mm ² AWG 18	Connect to Mains Neutral terminal (AC)

3.2.5 CURRENT TRANSFORMERS

 **WARNING!** Do not disconnect this plug when the CTs are carrying current. Disconnection open circuits the secondary of the C.T.'s and dangerous voltages may then develop. Always ensure the CTs are not carrying current and the CTs are short circuit connected before making or breaking connections to the module.

 **NOTE:** The module has a burden of 0.25 VA on the CT. Ensure the CT is rated for the burden of the controller, the cable length being used and any other equipment sharing the CT. If in doubt, consult with the CT supplier.

 **NOTE:** Take care to ensure correct polarity of the CT primary as shown below. If in doubt, consult with the CT supplier.

Pin No	Description	Cable Size	Notes
29	CT Secondary for L1	2.5mm ² AWG 13	Connect to s1 secondary of L1 monitoring CT
30	CT Secondary for L2	2.5mm ² AWG 13	Connect to s1 secondary of L2 monitoring CT
31	CT Secondary for L3	2.5mm ² AWG 13	Connect to s1 secondary of L3 monitoring CT
32	CT Common	2.5mm ² AWG 13	Connect to s2 of the CTs connected to L1, L2 and L3

3.2.6 MPU & RS485

 **NOTE:** Screened 120 Ω impedance cable specified for use with RS485 must be used for the RS485 link. DSE stock and supply Belden cable 9841 which is a high quality 120 Ω impedance cable suitable for RS485 use (DSE part number 016-030)

Pin No	Description	Cable Size	Notes
33	Magnetic Pickup Screen	Shield	Connect To Ground At One End Only
34	Magnetic Pickup Negative	0.5 mm ² AWG 20	Connect To Magnetic Pickup Device
35	Magnetic Pickup Positive	0.5 mm ² AWG 20	Connect To Magnetic Pickup Device
36	RS485 Port A (-)	0.5 mm ² AWG 20	Connect to RXD- and TXD- Use only 120 Ω CAN or RS485 approved cable
37	RS485 Port B (+)	0.5 mm ² AWG 20	Connect to RXD+ and TXD+ Use only 120 Ω CAN or RS485 approved cable
38	RS485 Port Screen	Shield	Use only 120 Ω CAN or RS485 approved cable

3.2.6.1 CT CONNECTIONS

p1, \hat{k} or K is the primary of the CT that 'points' towards the Generator

p2, \hat{l} or L is the primary of the CT that 'points' towards the Load

s1 is the secondary of the CT that connects to the DSE Module's input for the CT measuring

s2 is the secondary of the CT that is connected with other common s2 connections of all the other CTs and connected to the CT common terminal of the module.

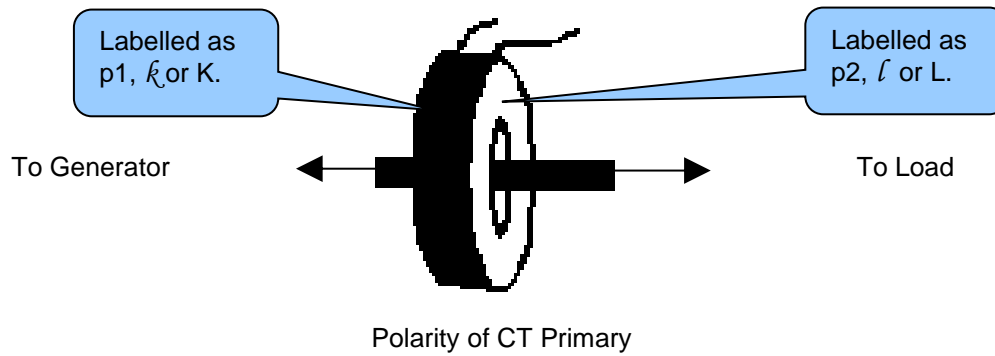



3.2.7 USB CONFIGURATION (PC CONFIGURATION) CONNECTOR

NOTE: The USB connection cable between the PC and the module must not be extended beyond 5 m (yards). For distances over 5 m, it is possible to use a third party USB extender. Typically, they extend USB up to 50 m. The supply and support of this type of equipment is outside the scope of Deep Sea Electronics Ltd.

CAUTION! Care must be taken not to overload the PC's USB system by connecting more than the recommended number of USB devices to the PC. For further information, consult a PC supplier.

NOTE: For further details of module configuration, refer to DSE Publication: *057-378 DSEG4500 & DSEG4501 Configuration Suite Software Manual*.

	Description	Cable Size	Notes
	Socket for connection to PC with DSE Configuration Suite Software	0.5 mm ² AWG 20	This is a standard USB type A to type B connector. 

3.3 TYPICAL SCHEMATIC DIAGRAM

As every system has different requirements, these diagrams show only a typical system and do not intend to show a complete system.

Genset manufacturers and panel builders may use these diagrams as a starting point; however always refer to the completed system diagram provided by the system manufacturer for complete wiring detail.

Further wiring suggestions are available in the following DSE publications, available at www.deepseaelectronics.com to website members.

DSE Part	Description
057-004	Electronic Engines and DSE Controllers
056-005	Using CTs With DSE Products
056-022	Switchgear Control
056-091	Equipotential Earth Bonding
056-092	Recommended Practices for Wiring Resistive Sensors

3.3.1 DSEG4500 TYPICAL SCHEMATIC DIAGRAMS

3.3.1.1 AUTOMATIC MAINS FAILURE

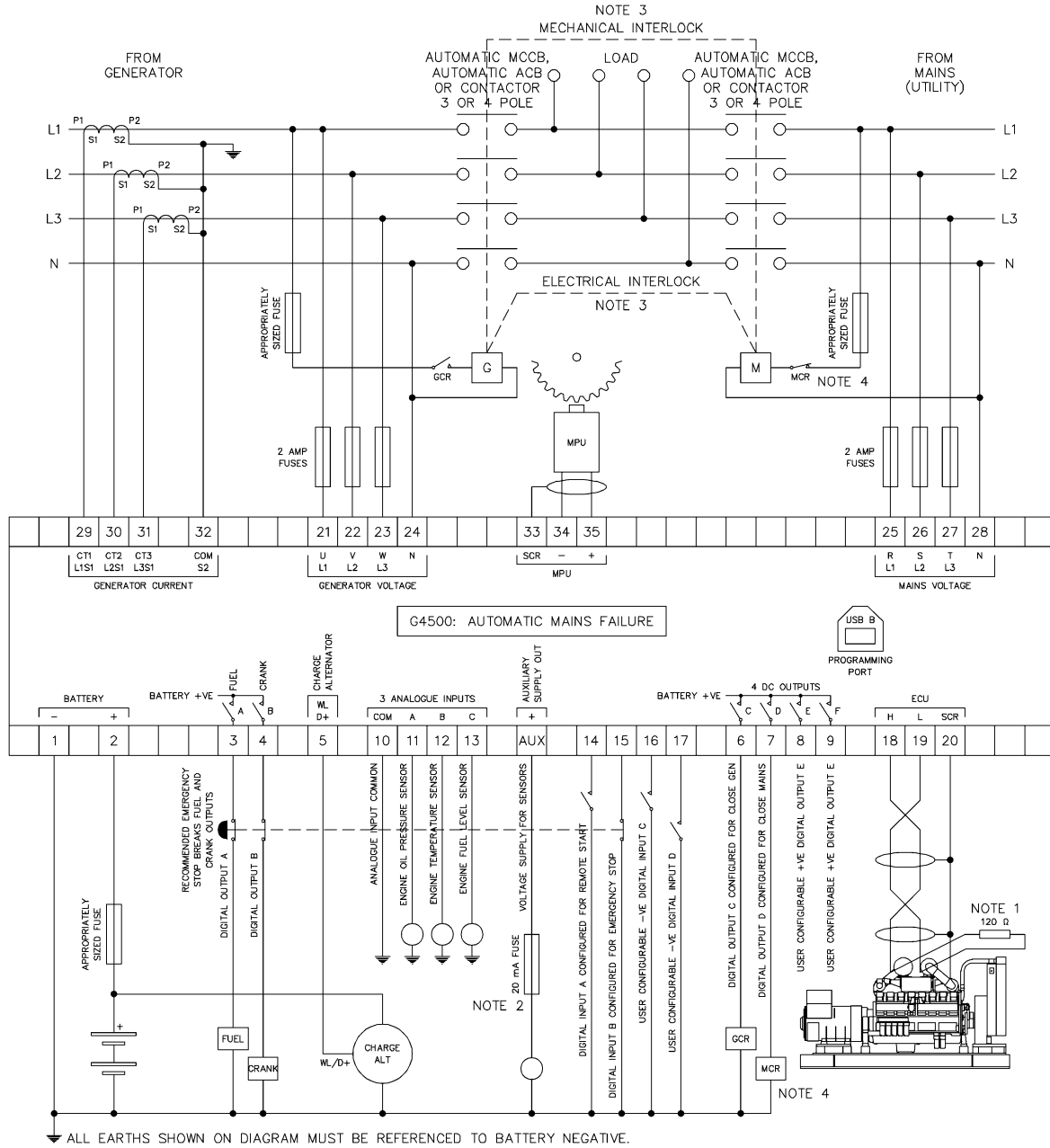

NOTE 1: A 120 Ω TERMINATION RESISTOR MAY BE REQUIRED EXTERNALLY, REFER TO ENGINE MANUFACTURER'S LITERATURE.

NOTE 2: FUSE AS CLOSE TO THE DSE MODULE'S TERMINAL AS POSSIBLE.

NOTE 3: IT IS RECOMMENDED THAT THE GENERATOR AND MAINS SWITCHGEAR ARE MECHANICALLY AND ELECTRICALLY INTERLOCKED.

NOTE 4: CLOSE MAINS OUTPUT SHOULD BE CONFIGURED FOR DE-ENERGISE AND DRIVE THE NORMALLY CLOSED CONTACT OF MCR.

Installation

3.3.1.2 REMOTE START

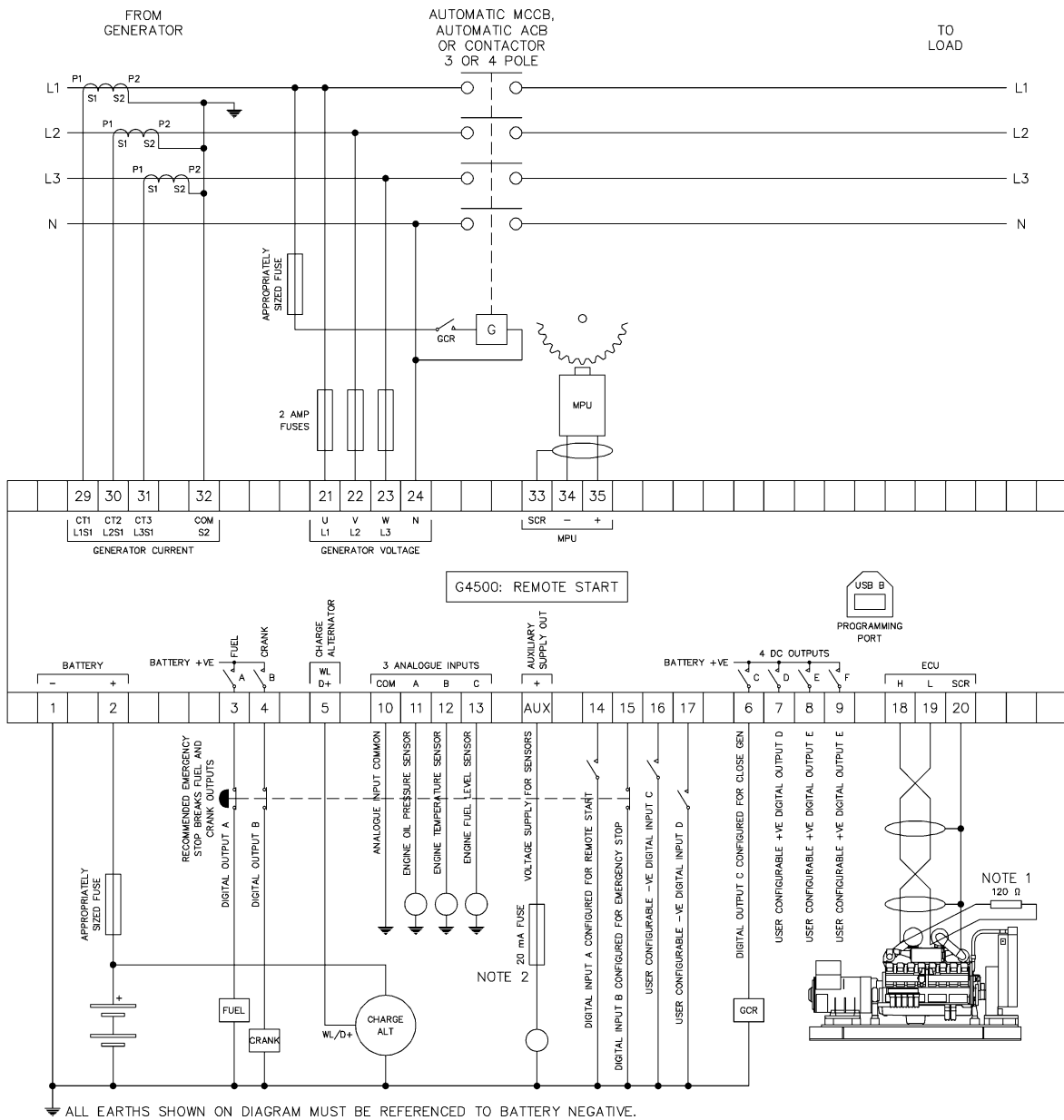

3.3.2 DSEG4501 TYPICAL SCHEMATIC DIAGRAMS

3.3.2.1 AUTOMATIC MAINS FAILURE

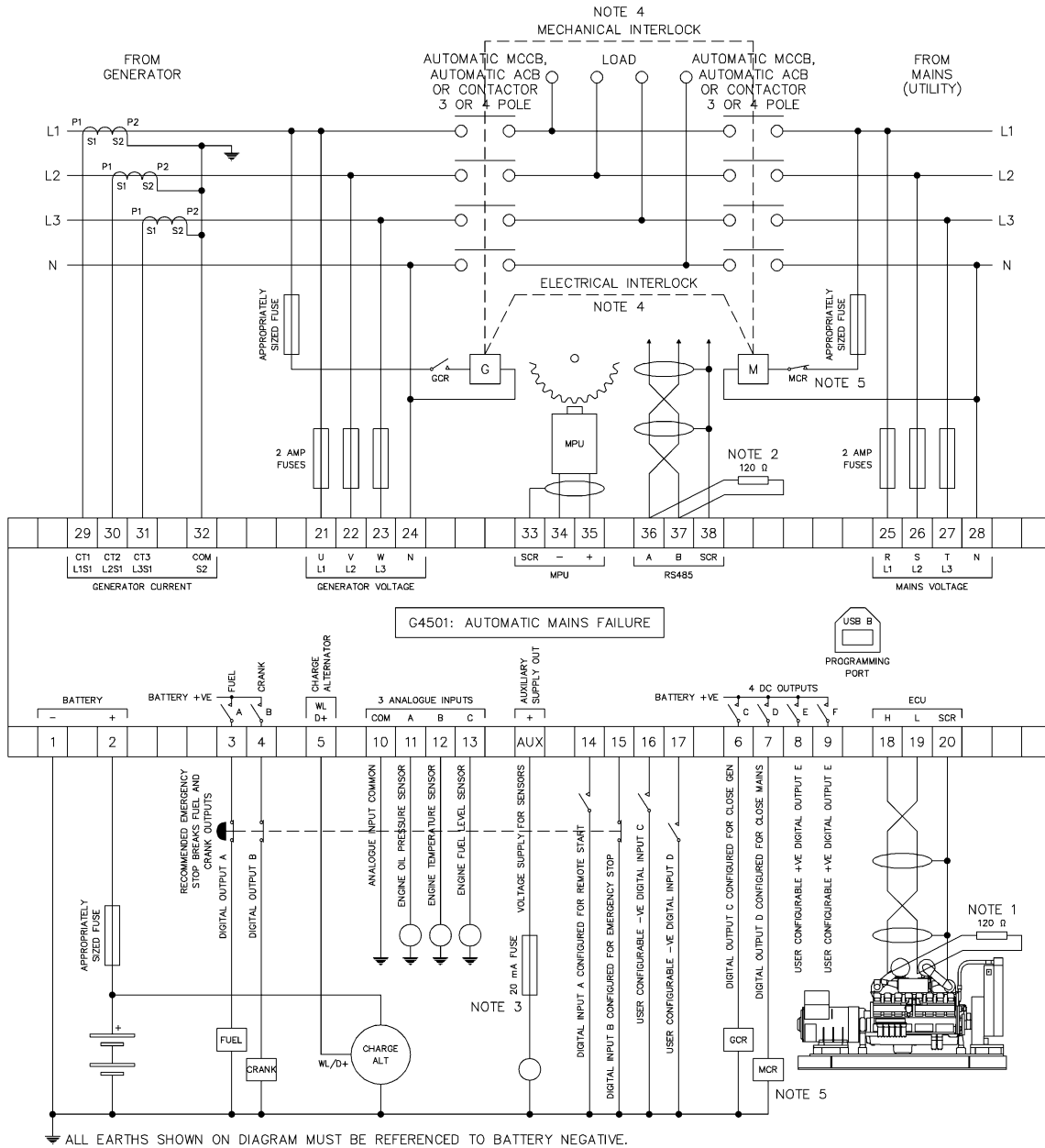

NOTE 1: A 120 Ω TERMINATION RESISTOR MAY BE REQUIRED EXTERNALLY, REFER TO ENGINE MANUFACTURER'S LITERATURE.

NOTE 2: IF THE MODULE IS FIRST OR LAST UNIT ON THE LINK, A 120 Ω TERMINATION RESISTOR MUST BE FITTED ACROSS A AND B.

NOTE 3: FUSE AS CLOSE TO THE DSE MODULE'S TERMINAL AS POSSIBLE.

NOTE 4: IT IS RECOMMENDED THAT THE GENERATOR AND MAINS SWITCHGEAR ARE MECHANICALLY AND ELECTRICALLY INTERLOCKED.

NOTE 5: CLOSE MAINS OUTPUT SHOULD BE CONFIGURED FOR DE-ENERGISE AND DRIVE THE NORMALLY CLOSED CONTACT OF MCR.

3.3.2.2 REMOTE START

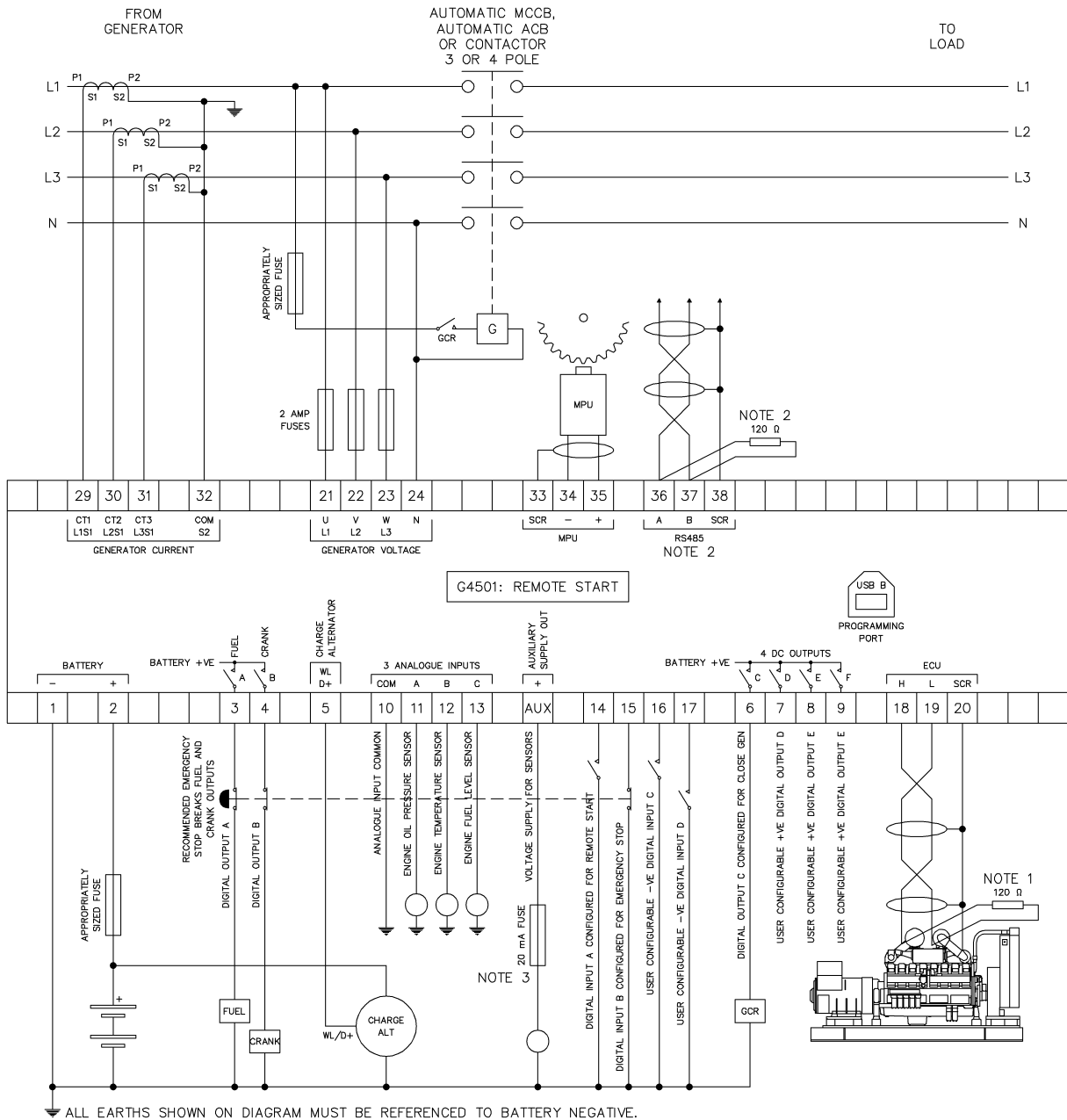

ALL EARTHS SHOWN ON DIAGRAM MUST BE REFERENCED TO BATTERY NEGATIVE.

NOTE 1: A 120 Ω TERMINATION RESISTOR MAY BE REQUIRED EXTERNALLY, REFER TO ENGINE MANUFACTURER'S LITERATURE.

NOTE 2: IF THE MODULE IS FIRST OR LAST UNIT ON THE LINK, A 120 Ω TERMINATION RESISTOR MUST BE FITTED ACROSS A AND B.

NOTE 3: FUSE AS CLOSE TO THE DSE MODULE'S TERMINAL AS POSSIBLE.

3.3.3 EARTH SYSTEMS

3.3.3.1 NEGATIVE EARTH

The typical schematic diagrams located within this document show connections for a negative earth system (the battery negative connects to Earth).

3.3.3.2 POSITIVE EARTH

When using a DSE module with a Positive Earth System (the battery positive connects to Earth), the following points must be followed:

Follow the typical schematic diagram as normal for all sections **except** the earth points. All points shown as Earth on the typical wiring diagram are connected to **battery negative** (not earth).

3.3.3.3 FLOATING EARTH

Where neither the battery positive nor battery negative terminals are connected to earth the following points must be followed:

Follow the typical schematic diagram as normal for all sections **except** the earth points. All points shown as Earth on the typical wiring diagram are connected to **battery negative** (not earth).

3.3.4 TYPICAL 0 MA TO 20 MA AND 0 V TO 10 V SENSOR SCHEMATIC

Typical Schematic For a 0 mA to 20 mA Loop Powered Sensor

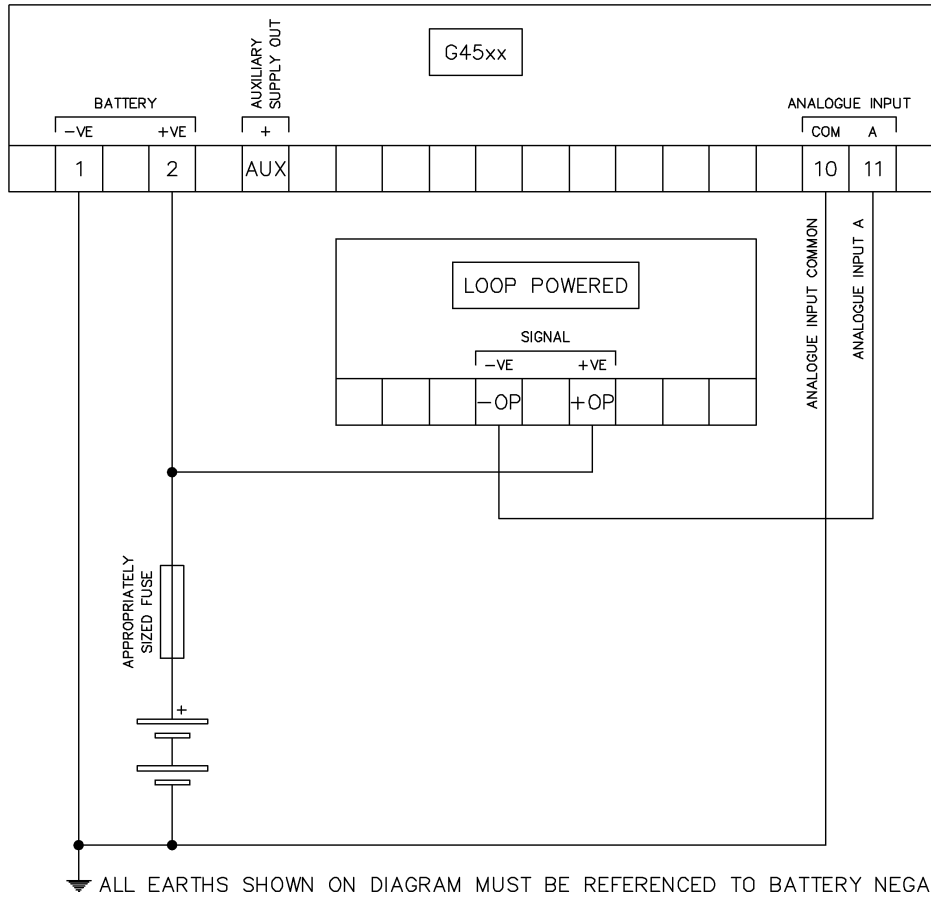

Typical Wiring For a Sensor That Requires a 5 V Supply

NOTE: The AUX sensor supply output is available for any type of sensor, a voltage sensor is used in the example below.

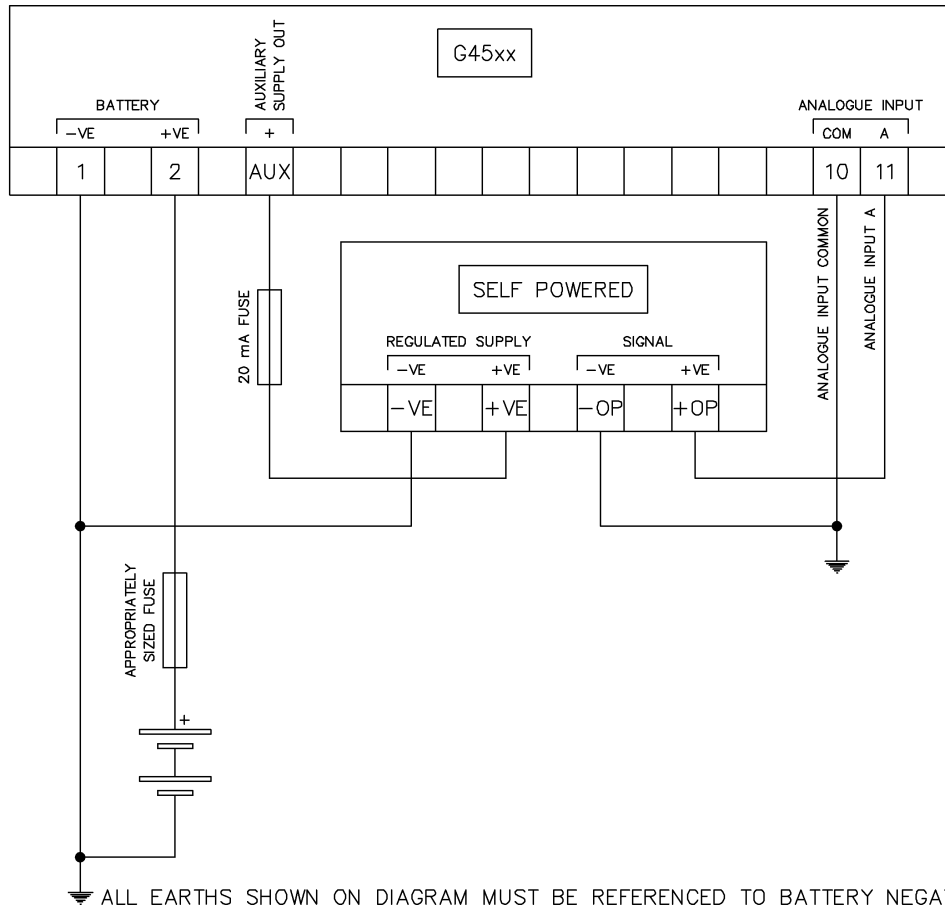

ALL EARTHS SHOWN ON DIAGRAM MUST BE REFERENCED TO BATTERY NEGATIVE

Typical Wiring For a Sensor That Requires a Battery Supply

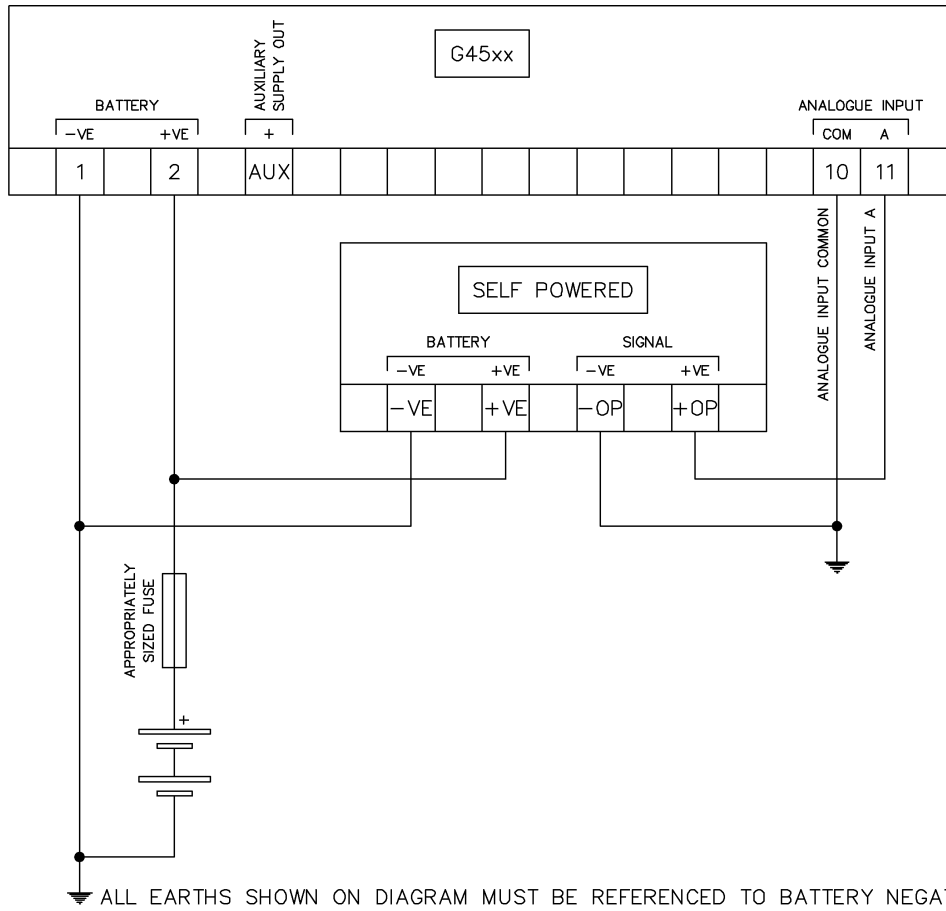

3.4.2 AUTOMATIC MAINS FAILURE 3 PHASE 3 WIRE

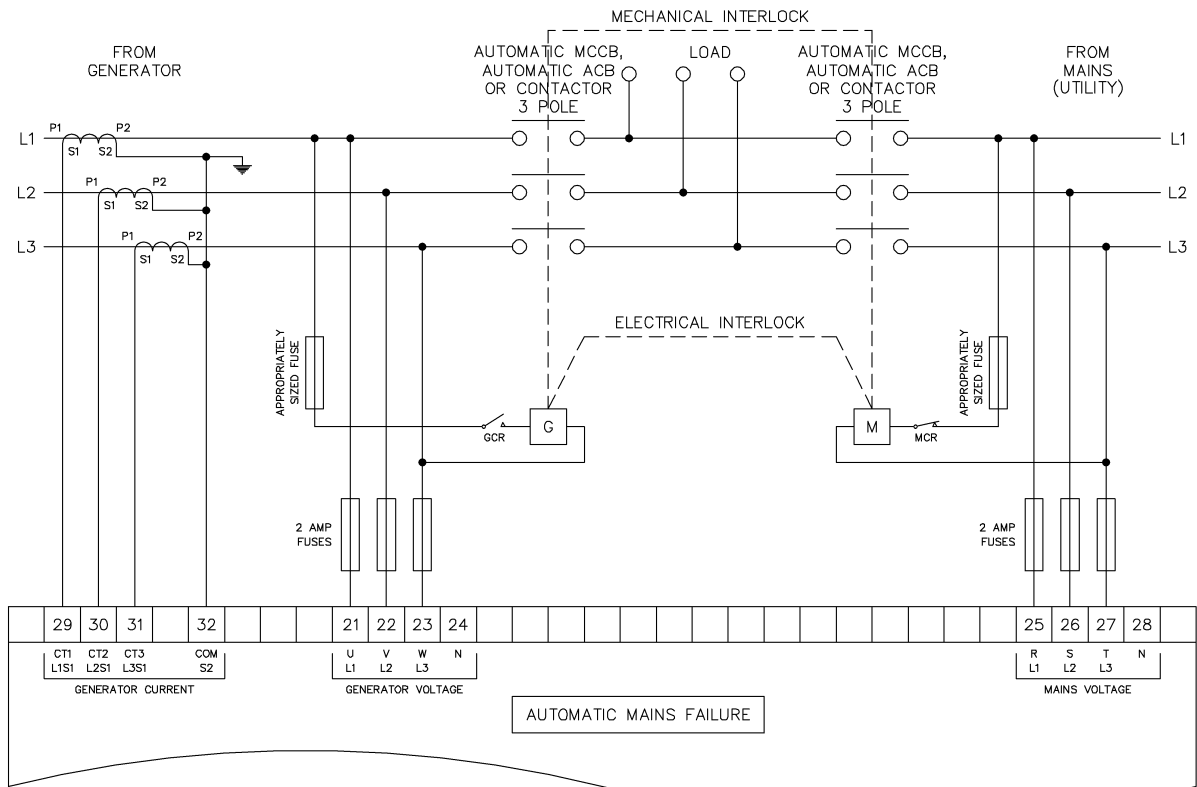

3.4.3 AUTOMATIC MAINS FAILURE 2 PHASE (L1, L2) 3 WIRE

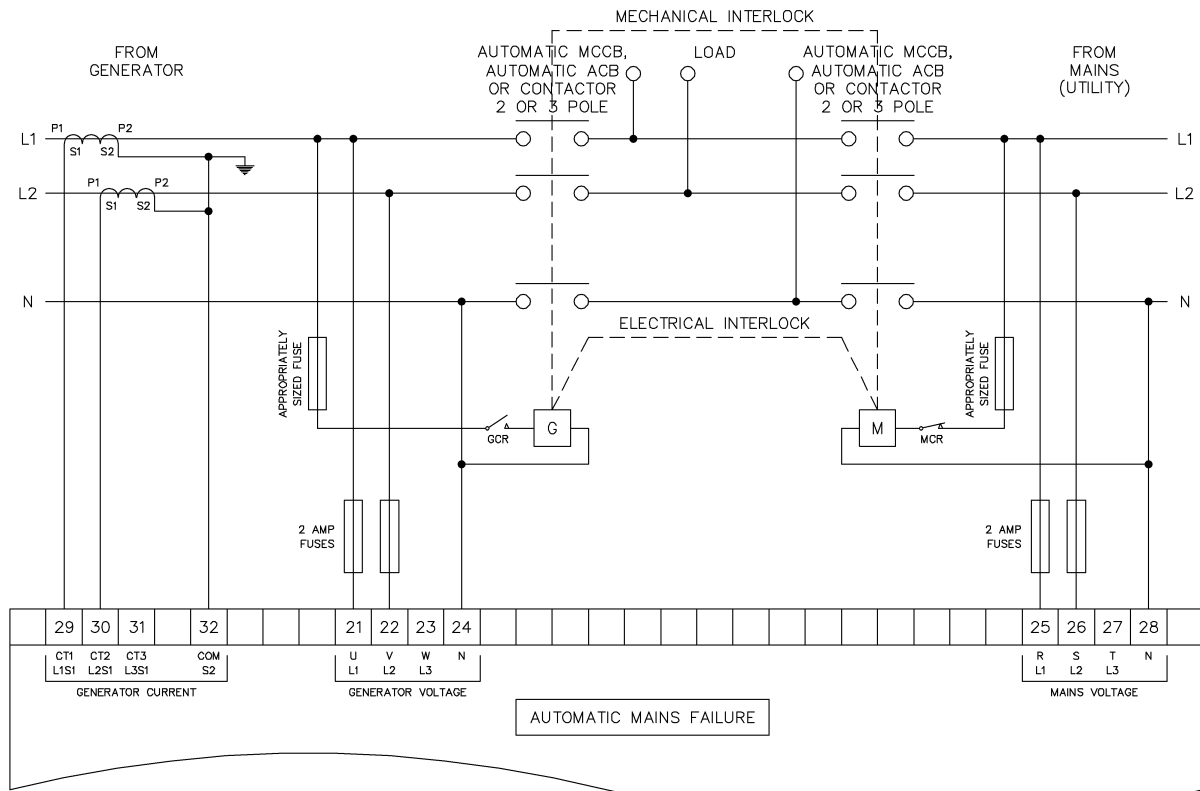

3.4.4 AUTOMATIC MAINS FAILURE 2 PHASE (L1, L3) 3 WIRE

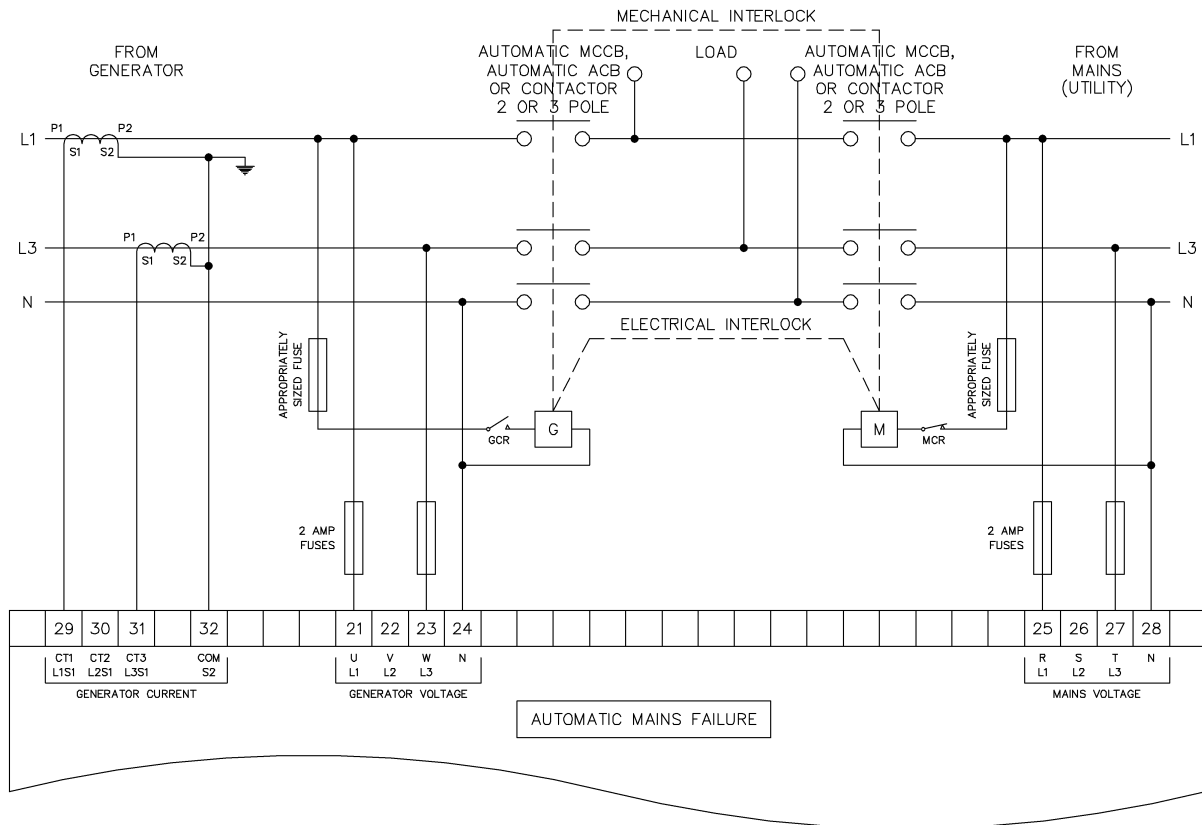

3.4.5 AUTOMATIC MAINS FAILURE SINGLE PHASE (L1, N) 2 WIRE

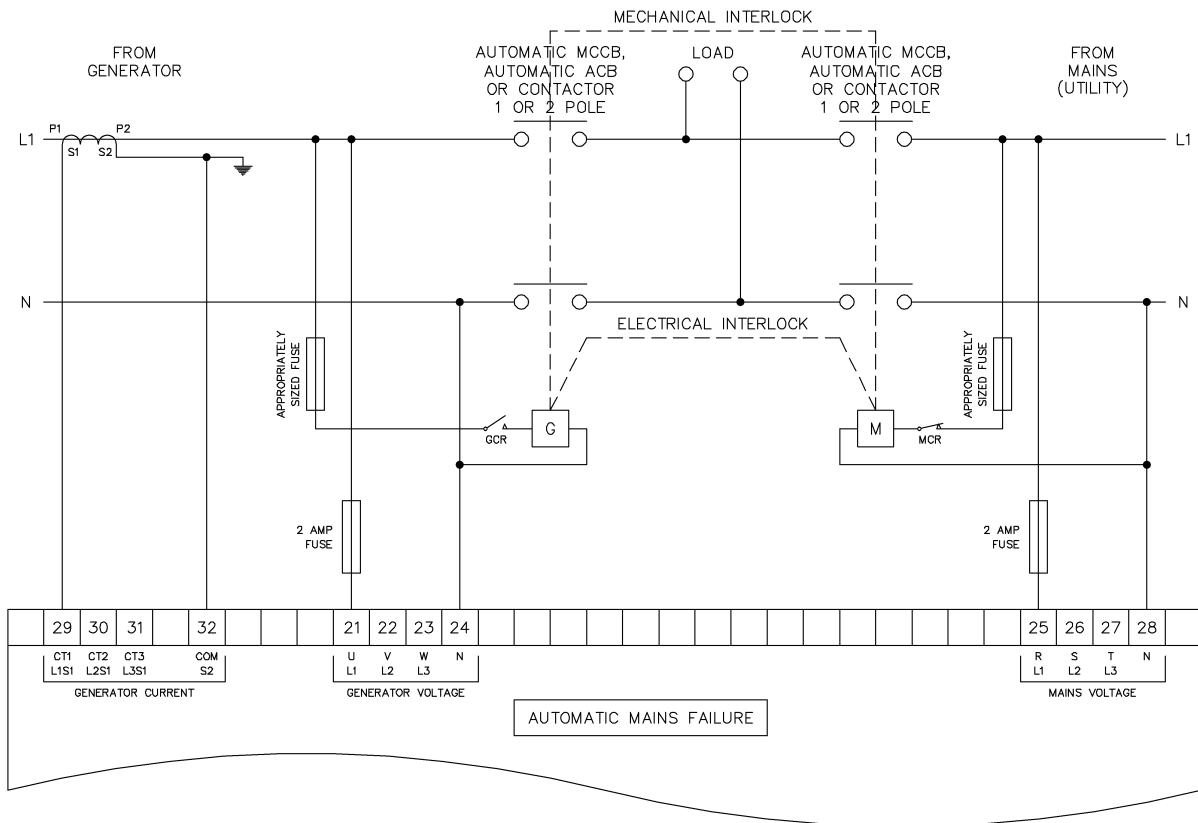

3.4.6 AUTOMATIC MAINS FAILURE 3 PHASE 4 WIRE

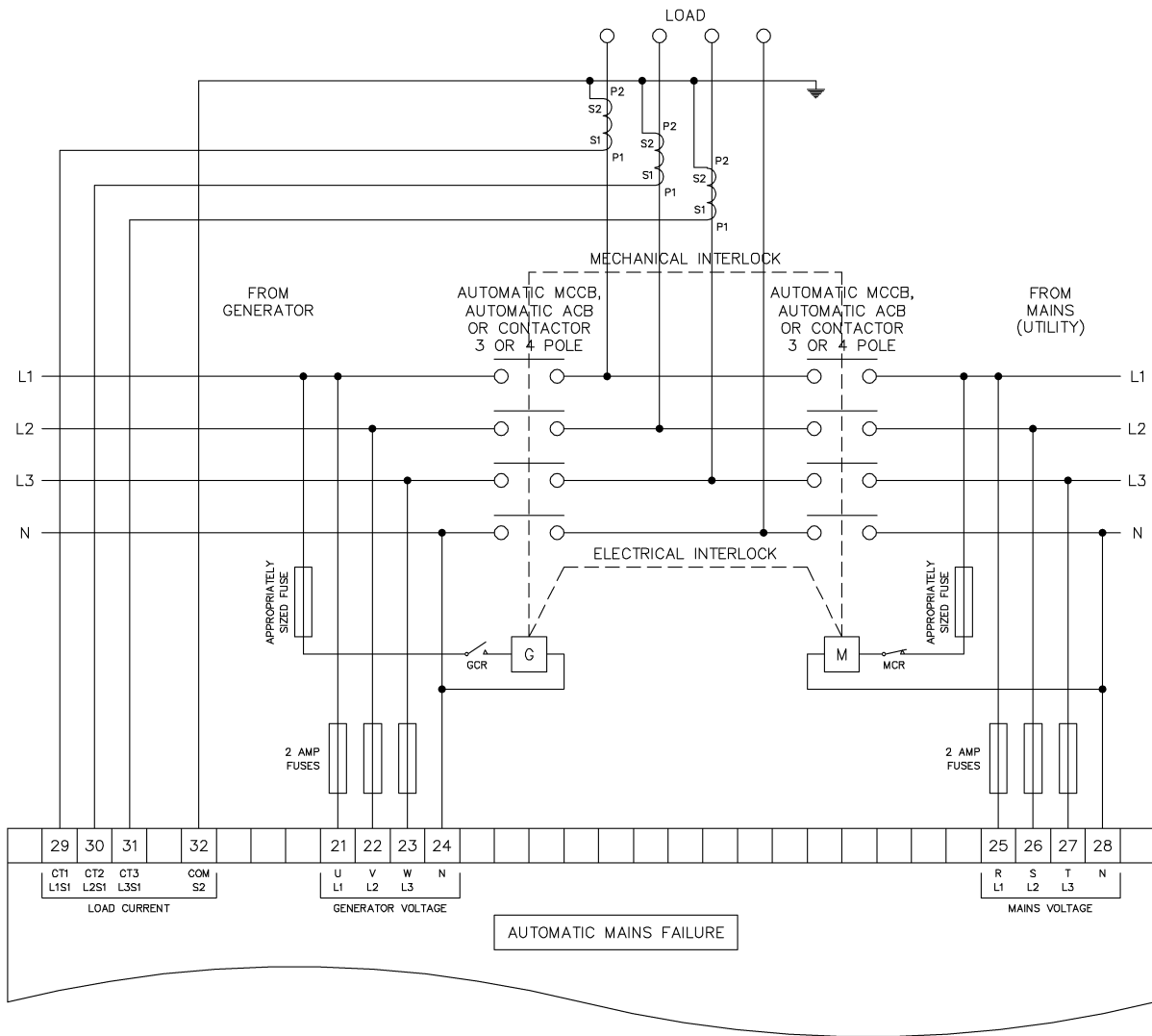

3.4.10 REMOTE START 2 PHASE (L1, L3) 3 WIRE

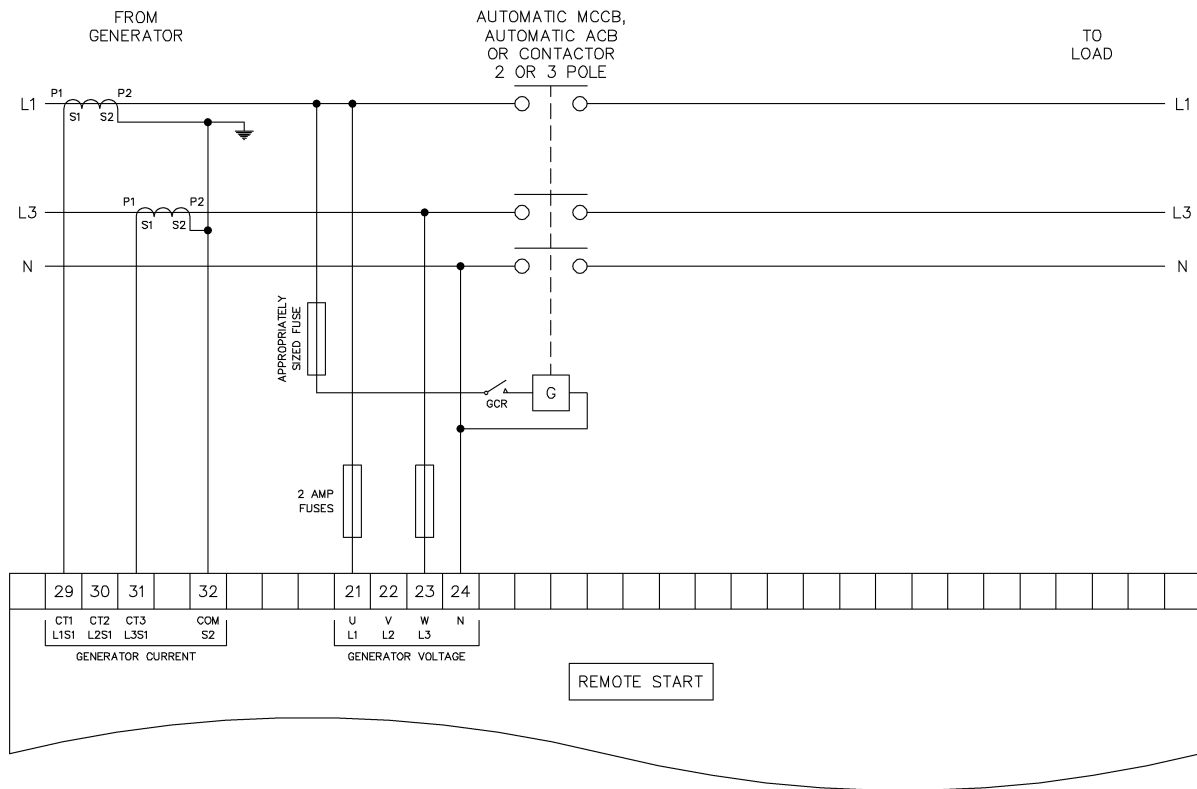

4 DESCRIPTION OF CONTROLS

CAUTION: The module may instruct an engine start event due to external influences. Therefore, it is possible for the engine to start at any time without warning. Prior to performing any maintenance on the system, it is recommended that steps are taken to remove the battery and isolate supplies.





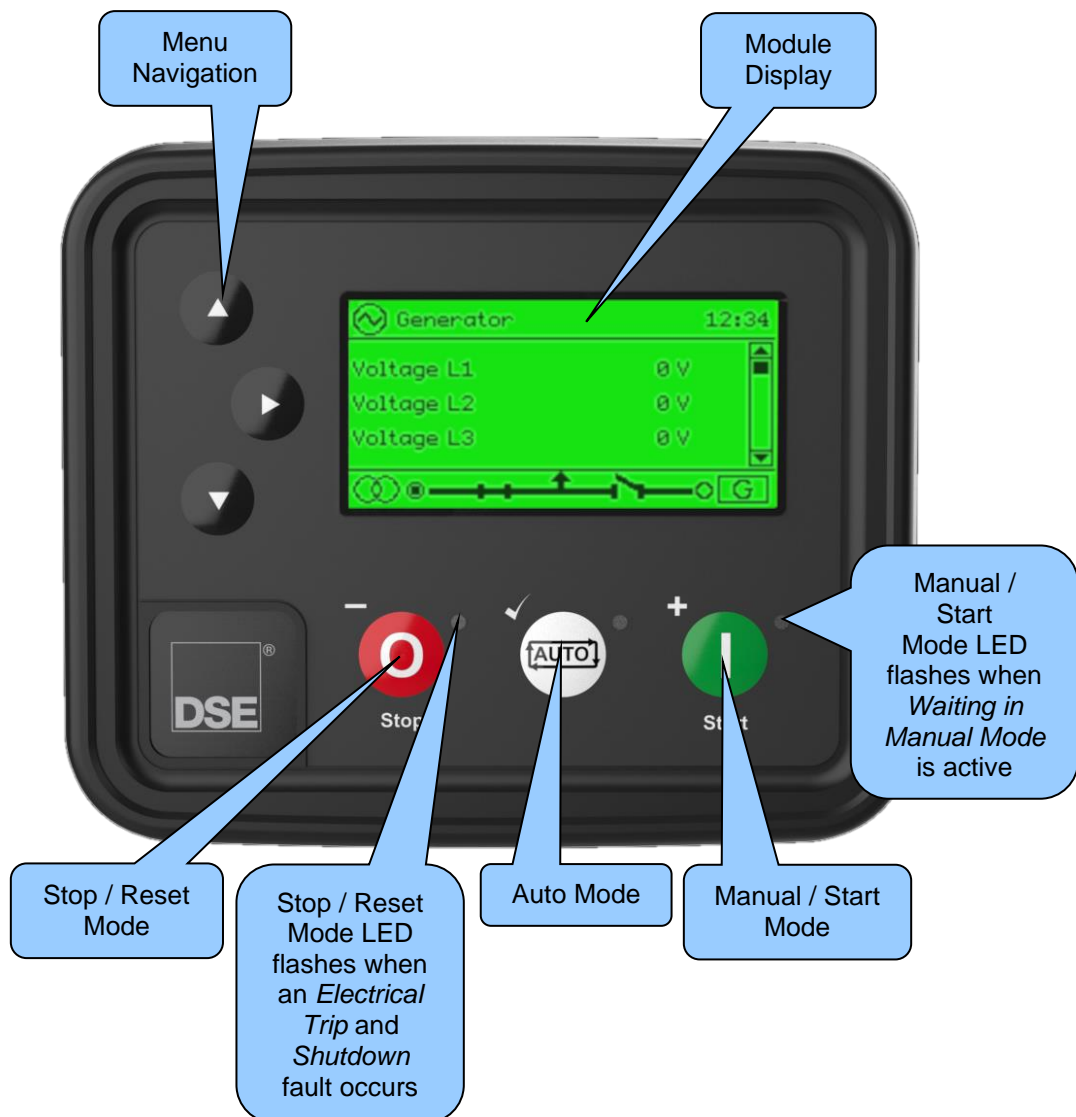

NOTE: The following descriptions detail the sequences followed by a module containing the standard 'factory configuration'. Always refer to the configuration source for the exact sequences and timers observed by any module in the field.

Control of the module is via push buttons mounted on the front of the module with **Stop/Reset Mode** (⊖), **Auto Mode** (AUTO) and **Manual/Start Mode** (⊕) functions. For normal operation, these are the only controls which need to be operated. Details of their operation are provided later in this document.







4.1 CONTROL PUSH BUTTONS

 **NOTE:** For further details, see section entitled *Operation* elsewhere in this manual.

Icon	Description
	<p>Stop / Reset Mode</p> <p>This button places the module into its Stop/Reset Mode . This clears any alarm conditions for which the triggering criteria has been removed. If the engine is running and the module is put into Stop/Reset Mode , the module automatically instructs the generator off load (Close Generator Output becomes inactive if used) and places the mains on load (Close Mains Output becomes active). The fuel supply de-energises and the engine comes to a standstill. The generator remains at rest if any form of start signal is present when in Stop/Reset Mode .</p> <p>For further details, see the more detailed section of <i>Operation</i> elsewhere in this manual.</p>
	<p>Auto Mode</p> <p>This button places the module into its Auto Mode . This mode allows the module to control the function of the generator automatically. The module monitors numerous start requests and when one has been made, the set is automatically started. Once the generator is available, the mains is taken off load (Close Mains Output becomes inactive) and the generator is placed on load (Close Generator Output becomes active if used and Delayed Load Output 1, 2, 3 & 4 becomes active if used).</p> <p>Upon removal of the starting signal, the module starts the <i>Return Delay Timer</i> and once expired, takes the generator off load (Close Generator Output becomes inactive if used and Delayed Load Output 1, 2, 3 & 4 becomes inactive if used) and places the mains on load (Close Mains Output becomes active). The generator then continues to run for the duration of the <i>Cooling Timer</i> until it stops. The module then waits for the next start event.</p> <p>For further details, see the more detailed section of <i>Operation</i> elsewhere in this manual.</p>

 **NOTE:** For further details, see section entitled *Operation* elsewhere in this manual.

Icon	Description
	<p>Manual/Start Mode</p> <p>This button starts the generator and runs it off load. To place the generator on load digital inputs are required to provide the loading/unloading instruction.</p> <p>If the engine is running off-load in Manual/Start Mode  and a <i>Remote Start Signal</i> becomes present, the module automatically instructs the changeover device to take the mains off load (Close Mains Output becomes inactive) and place the generator on load (Close Generator Output becomes active if used and Delayed Load Output 1, 2, 3 & 4 becomes active if used).</p> <p>Upon removal of the <i>Remote Start Signal</i>, the generator remains on load until Stop/Reset Mode  or Auto Mode  are selected.</p> <p>For further details, see the more detailed section of <i>Operation</i> elsewhere in this manual.</p>
	<p>Menu Navigation</p> <p>Used for navigating the instrumentation, event log and configuration screens.</p>

4.2 MODULE DISPLAY

The module's display contains the following sections. Description of each section can be viewed in the sub sections.

▲ NOTE: Depending upon the module's configuration, some display screens may be disabled. For further details of module configuration, refer to DSE Publication: *057-378 DSEG4500 & DSEG4501 Configuration Suite Software Manual.*

Standard Screen Layout

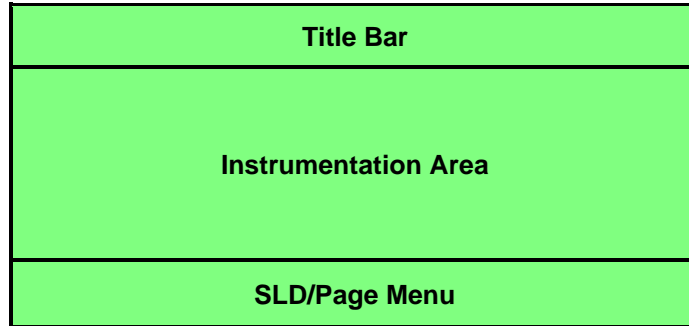

Home Screen Layout

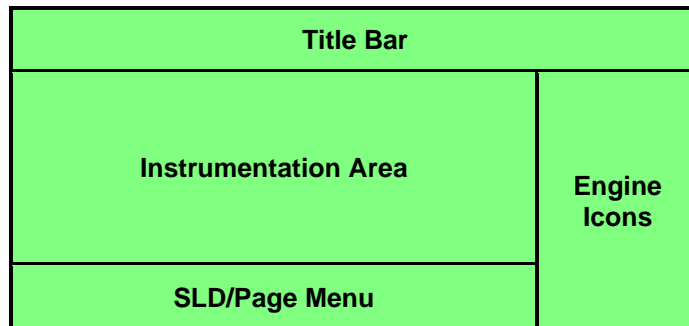

Example Home Screen Layout

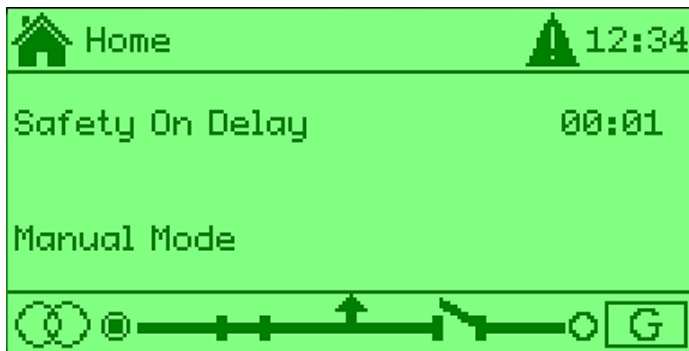

4.2.1 SINGLE LINE DIAGRAM (SLD)





NOTE: There are two types of SLD: one for the *Remote Start* module platform and another for the *Auto Mains Failure* platform, based on the module type configuration. Additionally, each of these SLD types is available in two sizes: a standard size screen in the Standard screen format and a reduced size for the home page in the Home screen format when the engine icon section is utilized.

The system summary, or single line diagram (SLD), is displayed at the bottom of the screen on all pages, with the exception of the FPE. It may, however, be obscured by the page menu while navigating between different sections. Virtual LED indicators located next to the generator and mains symbols (AMF only) indicate the availability of the generator and mains power.

Icon	Module Type	Details
	Remote Start	Appears when the generator is at rest or not available and when the generator breaker is open.
	Remote Start	Appears when the generator is at rest or not available and the generator breaker has failed to open.
	Remote Start	Appears when the generator is available, and the generator breaker is open.
	Remote Start	Appears when the generator is available, and the generator breaker is closed.
	AMF	Appears when the mains supply is not available, and the mains breaker is open.
	AMF	Appears when the mains supply is not available, and the mains breaker is closed.
	AMF	Appears when the mains supply is available, and the mains breaker is open.
	AMF	Appears when the mains supply is available, and the mains breaker is closed.

4.2.2 SPLASH SCREEN

An icon is displayed across the entire screen to indicate the when the configuration of the module is changed.

Icon	Details
	Appears when a USB connection is made to the controller.
	Appears if either the configuration file or engine file becomes corrupted.
	Appears when a configuration file is written to the module.
	Appears when the changes in the FPE have been confirmed.

4.2.3 BACKLIGHT

NOTE: It is possible to turn of the LCD backlight after a period of inactivity. For further details of module configuration, refer to DSE Publication: *057-378 DSEG4500 & DSEG4501 Configuration Suite Software Manual.*

The LCD backlight is on if the unit has sufficient voltage while the unit is turned on unless the unit is starting for which the backlight is turned off.





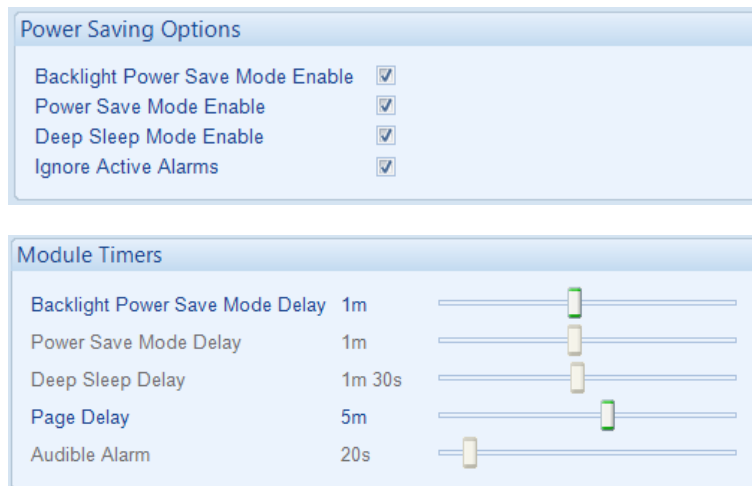









The unit supports an option for turning the LCD backlight off after a period without user interaction. The backlight may turn off during a time of inactivity when no facia control button is pressed. The backlight turns on again when a button is pressed, or an alarm is activated. The unit supports an option for turning the LCD backlight off whilst there is an active alarm.

Example of configuration to enable the LCD backlight to turn off after 1 minute of inactivity on the module's facia buttons whilst there is an active alarm:



4.3 VIEWING THE INSTRUMENT PAGES

4.3.1 PAGE MENU ICONS

Icon	Description
	Home page (either engine tier 4 or generator and voltage instrumentation, depending upon module configuration)
	Engine
	Generator instrumentation
	Mains instrumentation
	Alarms
	ECU Current DTC's (Diagnostic Trouble Codes) if active
	Event Log
	Scheduler
	Configurable CAN
	Maintenance
	Communication
	About
	FPE (Front Panel Editor)
	Engine Tier 4

4.3.2 GENERAL PAGE NAVIGATION

NOTE: For further details of module configuration, refer to DSE Publication: *057-378 DSEG4500 & DSEG4501 Configuration Suite Software Manual*.

NOTE: In addition to the standard navigation, the module includes a configurable *Page Change Delay* feature located in the *Front Panel Editor*. If no buttons are pressed within the set timeout period, the screen will automatically return to the home page. By default, the timeout is set to 10 seconds, but this can be adjusted as needed.

Users navigate through the pages using the right button, the icon corresponding to the current page is displayed in the leftmost position, while the other icons shift to the left (or to the right with a long press).

When there are more pages than can be shown as icons in the page menu, some icons may not be visible. Conversely, when there are fewer pages than can be accommodated in the menu, the icons are evenly spaced across the bar.

Example



And so on until the last page is reached. A further press of the right button returns the display to the Home page.



After a period of inactivity, (configurable with a default setting of 10 seconds), the menu will be replaced with the SLD until further navigation activity occurs.

Once selected, the page remains on the LCD display until the user selects a different page or, after an extended period of inactivity (*Page Delay Timer*), the module reverts to the Home  page. The *Page Delay Timer* is configurable using the DSE Configuration Suite Software or by using the Front Panel Editor.

Timer Name	Current Value
Power Save Mode Delay	1m
Deep Sleep Delay	1m 30s
Page Delay	5m

4.3.3 HOME

NOTE: Depending upon the module's configuration, the Home screen may be set to display electrical parameters or engine tier 4 information. For further details of module configuration, refer to DSE Publication: : 057-378 DSEG4500 & DSEG4501 Configuration Suite Software Manual.

This is the page that is displayed when no other page has been selected and is automatically displayed after a period of inactivity (*Page Delay Timer*) of the module facia buttons. Depending upon configuration, the page contains the voltage reading of the generator and mains that is measured from the module's voltage inputs or engine tier 4 information read from the CAN.

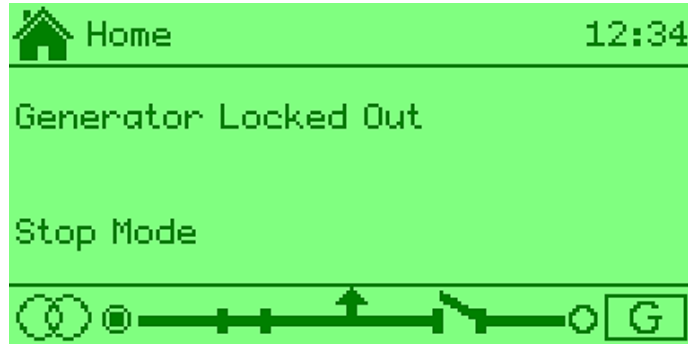

4.3.4 ENGINE

NOTE: For further details of supported engine instrumentation from CAN, refer to DSE Publication: *057-004 Electronic Engines and DSE Controllers*.

NOTE: Items marked with an asterisk are extra bar graph instrumentation which can be enabled through configuration. For further details of module configuration, refer to DSE Publication: *057-378 DSEG4500 & DSEG4501 Configuration Suite Software Manual*.

These pages contain instrumentation gathered about the engine measured or derived from the module's inputs, some of which may be obtained from the engine ECU.



- Engine Speed
- Engine Run Time
- Engine Battery Voltage
- Engine Charge Alternator Voltage
- Engine Coolant Temperature
- Engine Coolant Temperature or Flexible Sensor
- Engine Coolant Temperature Status
- Engine Coolant Level %
- Engine Oil Pressure
- Engine Oil Pressure or Flexible Sensor
- Engine Oil Pressure Status
- Engine Fuel Level or Flexible Sensor
- Engine Fuel Level %
- Engine Oil Temperature*
- Inlet Manifold Temperature*
- Exhaust Temperature 1* & 2*
- Coolant Pressure 1* & 2*
- Turbo Pressure 1* & 2*
- Fuel Consumption*
- Fuel Pressure*
- Fuel Used*
- Soot Level*
- Ash Level*
- DEF Level*
- DEF Temperature*
- DEF Consumption*
- DEF Inducement Reason*
- DEF Inducement Severity*
- EGR Pressure*
- EGR Temperature*
- Ambient Air Temp*

Description of Controls

- Air Intake Temp*
- Low Level Inducement Time*
- Severe Level Inducement Time*

4.3.4.1 DISPLAY MODE

NOTE: For further details of module configuration, refer to DSE Publication: **057-378 DSEG4500 & DSEG4501 Configuration Suite Software Manual.**

For some parameters there is the option to change the Display mode. The parameters can be viewed as Bar graphs or numerical values. This is configurable by using the DSE Configuration Suite software.

Oil Pressure

The screenshot shows a green display with the following text: "Engine 12:", "Oil Pressure 4.37 bar", "Oil Pressure [Bar Graph]", and "Oil Pressure OK". A callout box on the right contains the following text:

Indicates health of Oil Pressure.
NOT OK: Oil pressure is below 1 bar (100 kPa, 14.5 PSI)
OK: Oil pressure is above 1 bar (100 kPa, 14.5 PSI) after the Safety on Delay timer has expired.

Bar Graph	Pressure
	0 bar to 0.5 bar (0 kPa to 50 kPa, 0 PSI to 7.3 PSI)
	0.51 bar to 1 bar (51 kPa to 100 kPa, 7.4 PSI to 14.5 PSI)
	1.01 bar to 1.5 bar (101 kPa to 150 kPa, 14.6 PSI to 21.8 PSI)
	1.51 bar to 2 bar (151 kPa to 200 kPa, 21.9 PSI to 29 PSI)
	2.01 bar to 2.5 bar (201 kPa to 250 kPa, 29.1 PSI to 36.3 PSI)
	2.51 bar to 3 bar (251 kPa to 300 kPa, 36.4 PSI to 43.5 PSI)
	3.01 bar to 3.5 bar (301 kPa to 350 kPa, 43.6 PSI to 50.8 PSI)
	3.51 bar to 4 bar (351 kPa to 400 kPa, 50.9 PSI to 58 PSI)
	4.01 bar to 4.5 bar (401 kPa to 450 kPa, 58.1 PSI to 65.3 PSI)
	4.51 bar to 5 bar (451 kPa to 500 kPa, 65.4 PSI to 72.5 PSI)
	5.01 bar to 5.5 bar (501 kPa to 550 kPa, 72.6 PSI to 79.8 PSI)
	5.51 bar to 6 bar (551 kPa to 600 kPa, 79.9 PSI, 87 PSI)
	6.01 bar to 6.5 bar (601 kPa to 650 kPa, 87.1 PSI to 94.3 PSI)

Engine and Coolant Temperature

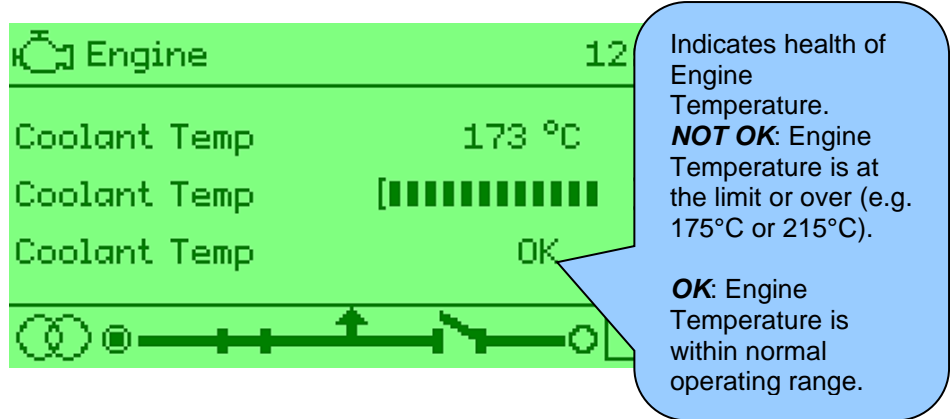

Engine Temperature has 2 different options for display mode the bars are not linear. The table below can be referenced for the Temperature represented in the bar graph.

Bar Graph	No of Bars	Temperature for 80 °C to 175 °C	Temperature for 80 °C to 215 °C
█	1	0 °C to 80 °C (32 °F to 176 °F)	0 °C to 80 °C (32 °F to 176 °F)
██	2	81 °C to 87 °C (178 °F to 189 °F)	81 °C to 90 °C (178 °F to 194 °F)
███	3	88°C to 94°C (190°F to 201°F)	91°C to 100°C (196°F to 212°F)
████	4	95 °C to 101 °C (203 °F to 214 °F)	101 °C to 109 °C (214 °F to 228 °F)
█████	5	102 °C to 108 °C (216 °F to 226 °F)	110 °C to 119 °C (230 °F to 246 °F)
██████	6	109 °C to 115 °C (228 °F to 239 °F)	120 °C to 129 °C (248 °F to 264 °F)
████████	7	116 °C to 122 °C (241 °F to 462 °F)	130 °C to 139 °C (266 °F to 282 °F)
█████████	8	123 °C to 129°C (253 °F to 264 °F)	140 °C to 149 °C (284 °F to 300 °F)
██████████	9	130°C to 136°C (266 °F to 276.8 °F)	150 °C to 159 °C (302 °F to 318 °F)
███████████	10	137 °C to 143 °C (279 °F to 289 °F)	160 °C to 169 °C (320 °F to 336 °F)
████████████	11	144 °C to 151 °C (291 °F to 304 °F)	170°C to 179°C (338 °F to 354 °F)
█████████████	12	152 °C to 159 °C (306 °F to 318 °F)	180 °C to 189 °C (356 °F to 372 °F)
██████████████	13	160 °C to 167 °C (320 °F to 333 °F)	190 °C to 199 °C (374 °F to 390 °F)
███████████████	14	168 °C to 175 °C (334 °F to 347 °F)	200 °C to 207 °C (392 °F to 405 °F)
████████████████	15	N/A	208 °C to 215 °C (406 °F to 419 °F)

Fuel Level

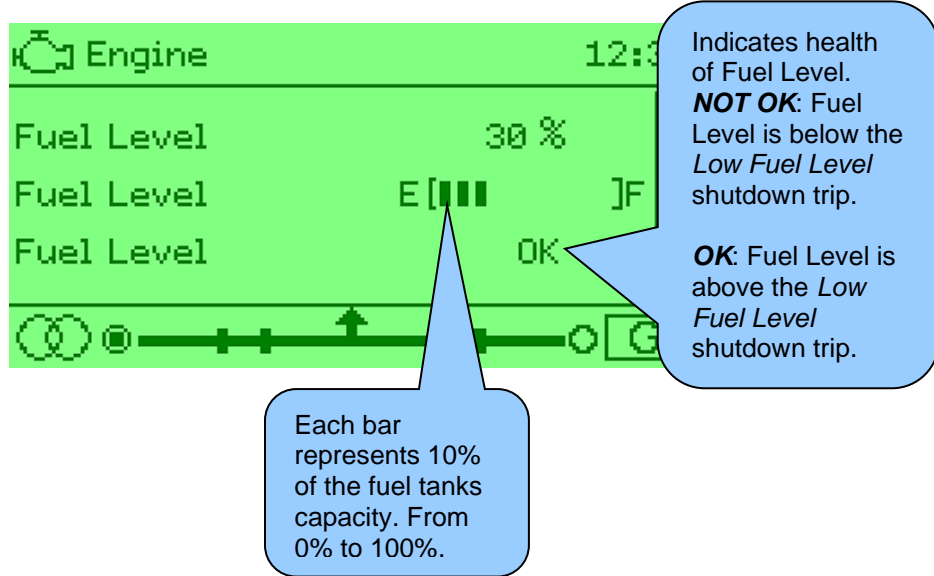

4.3.5 GENERATOR

NOTE: The Generator screen is hidden if no alternator is fitted. For further details of module configuration, refer to DSE Publication: *057-378 DSEG4500 & DSEG4501 Configuration Suite Software Manual*.

These pages contain electrical values of the generator, measured, or derived from the module's voltage inputs.

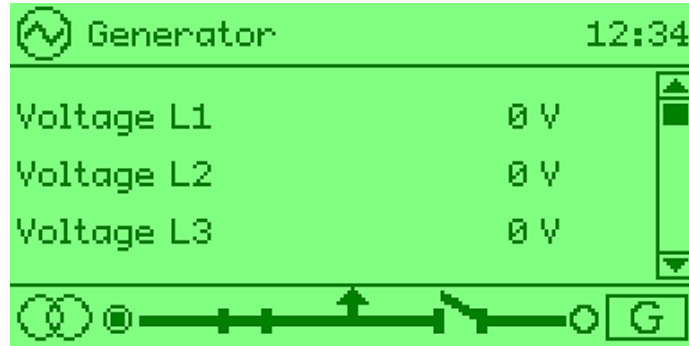

- Generator Voltage (ph-N)
- Generator Voltage (ph-ph)
- Generator Frequency
- Current L1
- Current L2
- Current L3
- kW L1
- kW L2
- kW L3
- kW Total
- kW Total %
- kVA L1
- kVA L2
- kVA L3
- kVA Total
- kVA L1
- kVA L2
- kVA L3
- kVA Total
- Power Factor L1
- Power Factor L2
- Power Factor L3
- Average Power Factor
- Accumulated kW
- Accumulated kVA
- Accumulated kVA
- Accumulated kVA
- Load Unbalance

4.3.6 MAINS

NOTE: The Mains screen is hidden when *Auto Start* is selected. For further details of module configuration, refer to DSE Publication: *057-378 DSEG4500 & DSEG4501 Configuration Suite Software Manual*.

These pages contain electrical values of the mains, measured, or derived from the module's voltage inputs.

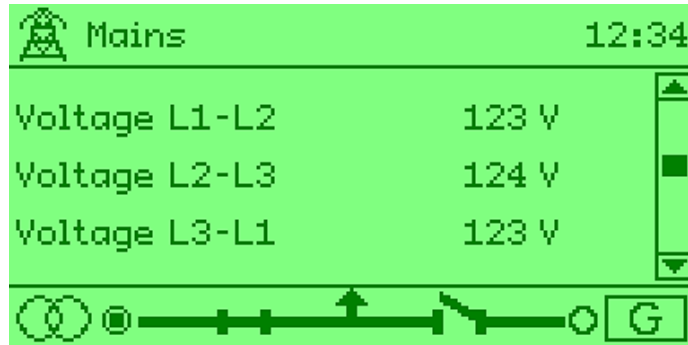

- Mains Voltage (ph-N)
- Mains Voltage (ph-ph)
- Mains Frequency
- Current L1
- Current L2
- Current L3

4.3.7 ALARMS

The *Alarms* page displays the details of the currently active alarms on the module in a list format suitable for the instrumentation area. Each alarm's details are presented on a single screen, indicating the alarm type and the corresponding alarm action *Warning*, *Shutdown* or *Electrical Trip*.



4.3.8 ENGINE DTC (ECU ALARMS)

NOTE: For details on these code meanings, refer to the ECU instructions provided by the engine manufacturer, or contact the engine manufacturer for further assistance.

NOTE: For further details on connection to electronic engines, refer to DSE Publication: *057-004 Electronic Engines and DSE Controllers.*

If the DSE module is connected to an ECU, this page contains active *Diagnostic Trouble Codes (DTC)* only if the engine ECU is generating a fault code. These alarm conditions are detected by the engine ECU and displayed by the DSE controller.

The DTC pages display the details of the currently active DTCs detected on the module in a list instrumentation area layout. Each DTC is presented on a single screen, providing information such as description, fault code, SPN, FMI, and OC in the following format:

The screenshot shows a green background with white text. At the top, it says 'ECU Current DTCs' with a warning icon on the left and the time '12:34' on the right. Below this, the text reads 'Start-up Failed Trip', 'Fault Exists', and 'SPN=520193 FMI=31 OC=12'. At the bottom right of the main text area, it says '1/3'. A vertical scrollbar is on the right side. At the bottom of the screen, there is a navigation bar with several icons: a warning icon, a book icon, a calendar icon, a CAN bus icon, a network icon, an information icon, and a right arrow icon. Two blue callout boxes are present: one on the left pointing to the text 'Start-up Failed Trip' and 'Fault Exists' with the text 'Description and fault code of active DTC alarm'; and one on the right pointing to the '1/3' text with the text 'Number of DTC displayed out of number of active DTCs.'

KW2000 & MTU

The screenshot shows a green background with white text. At the top, it says 'ECU Current DTCs' with a warning icon on the left and the time '12:34' on the right. Below this, the text reads 'Check Engine', 'DTC=5600, OC=7'. At the bottom right of the main text area, it says '1/3'. A vertical scrollbar is on the right side. At the bottom of the screen, there is a navigation bar with several icons: a warning icon, a book icon, a calendar icon, a CAN bus icon, a network icon, an information icon, and a right arrow icon.

4.3.9 EVENT LOG

The module's *Event Log* contains a list of the last 50 record electrical trips, shutdowns, mains fails, mains returns and power up events and the engine hours at which they occurred.

Once the log is full, any subsequent electrical trip or shutdown alarms overwrites the oldest entry in the log. Hence, the log always contains the most recent shutdown alarms. The module logs the alarm, along with the engine running hours.

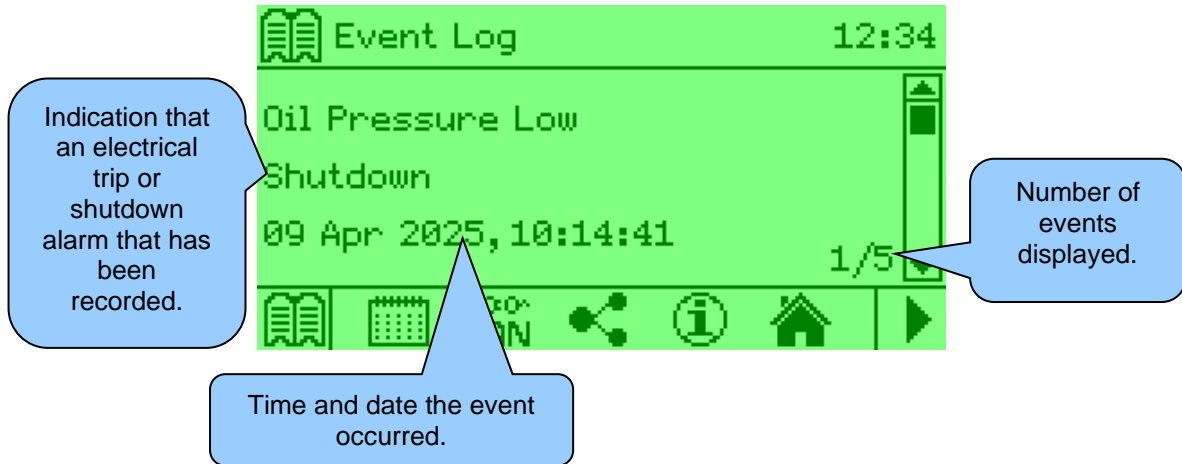

The events shown in the below table are recorded into the module's event log in addition to all electrical trip and shutdown alarms.

Event	Description
Mains Failure	The mains supply was detected as failed as it had risen above or fallen below the pre-set alarm setting.
Mains Return	The mains supply was detected as healthy as it was no longer in a fault condition.
Module Power Up	The module was powered up.

4.3.10 SCHEDULER

The *Scheduler* page gives details of the schedule currently configured. If the exercise schedule is not enabled, the page is not displayed (or shown in the page menu). A scroll bar on the right-hand side of the screen indicates the position of the currently displayed scheduler entry in the list of 8 entries. Each scheduler entry is shown on a single screen, giving scheduler action (On Load/Off Load), start time, duration, day, week (if the schedule period is weekly, or a blank if monthly), and the number of the scheduler entry (1-8) in the following format:

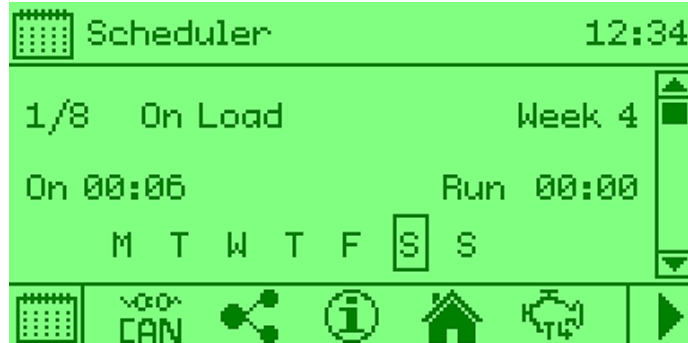

4.3.11 CONFIGURABLE CAN INSTRUMENTS

NOTE: Depending upon the module's configuration, some display screens may be disabled. For further details of module configuration, refer to DSE Publication: *057-378 DSEG4500 & DSEG4501 Configuration Suite Software Manual*.

The *Configurable CAN Instruments* page is intended to display CAN information from external third party CAN devices such as fuel flow meters. The contents of these screens vary depending upon configuration by the engine manufacturer or supplier.

Under default factory settings the configurable CAN instruments are not viewable. They are configurable by the system designer using the DSE Configuration Suite software.



- Configurable CAN Instrumentation 1 to 10

4.3.12 COMMUNICATIONS

The *Communications* page displays the current communications options and status in a single scrollable list.

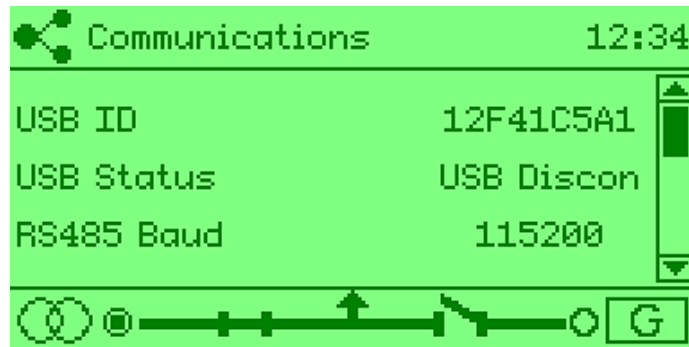

- USB ID
- USB Status
- RS485 Baud (G4501)
- RS485 Server ID (G4501)

4.3.13 ABOUT

These pages contain information about the controller.

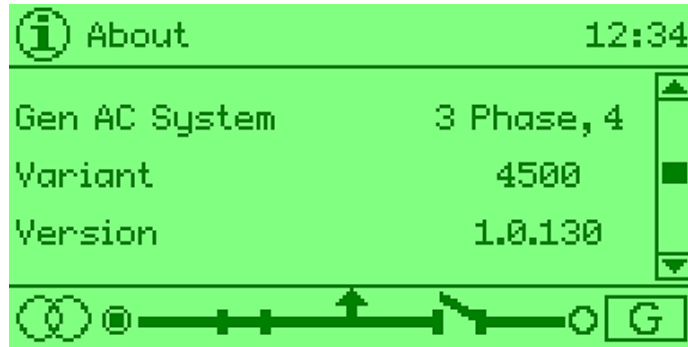

- Platform
- Active Configuration
- Mains AC System
- Gen AC Sysytem
- Variant
- Version
- Engine Type
- Engine Version



4.3.14 ENGINE TIER 4 INFORMATION



 **NOTE:** For further details of module configuration, refer to DSE Publication: *057-378 DSEG4500 & DSEG4501 Configuration Suite Software Manual*.

 **NOTE:** For details on these icon meanings, refer to the ECU instructions provided by the engine manufacturer, or contact the engine manufacturer for further assistance.

 **NOTE:** For further details on connection to electronic engines, refer to DSE Publication: *057-004 Electronic Engines and DSE Controllers*.

If the DSE module is connected to an ECU, this page contains active *Engine Tier 4 Lamps* only if the engine ECU is generating a fault code. These alarm conditions are detected by the engine ECU and displayed by the DSE controller.

To view the *Engine Tier 4 Lamps* or *DPF Inhibit Control* page, press on the right button  until it cycles to the *Engine Tier 4* () section.

Holding down the  (up) or  (down) button scrolls through previous alarms. Once all past alarms have been displayed, the most recent alarm appears again, and the cycle restarts.

To exit the *Engine Tier 4* section, press on the right button  until it cycles the desired page.

4.3.14.1 ENGINE TIER 4 LAMPS

NOTE: Depending upon the module's configuration, the home screen may be set to display engine tier 4 information. For further details of module configuration, refer to DSE Publication: 057-378 DSEG4500 & DSEG4501 Configuration Suite Software Manual.





Icon	Fault	Description
	DPF Stop	The module received a fault indication from the engine ECU informing that the <i>Diesel Particulate Filter</i> has been stopped.
	DPF Warning	The module received a fault condition from the engine ECU informing that the <i>Diesel Particulate Filter</i> has a fault condition.
	HEST Active	The module received a fault indication from the engine ECU informing that the <i>High Exhaust System Temperature</i> is active.
	DEF Low Level	The module received a fault condition from the engine ECU informing that the <i>Diesel Exhaust Fluid Low Level</i> is active.
	SCR Inducement	The module received a fault indication from the engine ECU informing that the <i>Selective Catalytic Reduction Inducement</i> is active.

4.3.14.2 DPF INHIBIT CONTROL

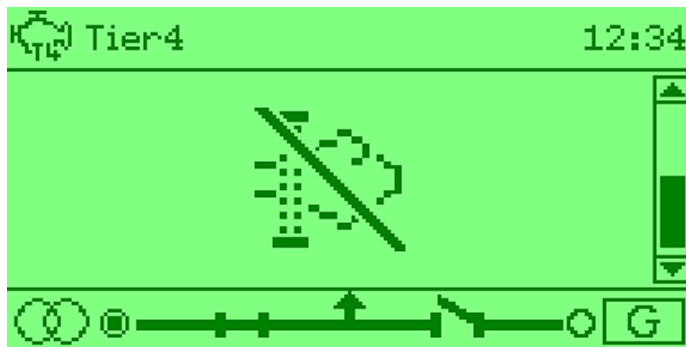
To inhibit or enable the DPF Control, press the **Auto Mode**  (✓) button.



Icon	Fault	Description
	DPF Active	The module received a fault indication from the engine ECU informing that the <i>Diesel Particulate Filter</i> is active.
	DPF Inhibited	The module received a fault indication from the engine ECU informing that the <i>Diesel Particulate Filter</i> has been inhibited.

5 OPERATION

NOTE: The following descriptions detail the sequences followed by a module containing the standard 'factory configuration'. Always refer to the configuration source for the exact sequences and timers observed by any module in the field.

5.1 QUICKSTART GUIDE

This section provides a quick start guide to the module's operation.

5.1.1 STARTING THE ENGINE

NOTE: For further details, see the section entitled *Operation* elsewhere in this document.



5.1.2 STOPPING THE ENGINE

NOTE: For further details, see the section entitled *Operation* elsewhere in this document.



5.2 STOP/RESET MODE

NOTE: If a digital input configured to *Panel Lock* is active, changing module modes is not possible. Viewing the instruments and event logs is NOT affected by *Panel Lock*.

NOTE: For further details of module configuration, refer to DSE Publication: *057-378 DSEG4500 & DSEG4501 Configuration Suite Software Manual*.

Stop/Reset Mode is activated by pressing the **Stop/Reset Mode** button.

In **Stop/Reset Mode**, the module removes the generator from load (if necessary) before stopping the generator.

If the generator does not stop when requested, the **Fail To Stop** alarm is activated (subject to the setting of the *Fail to Stop* timer). To detect the engine at rest the following must occur:

- Engine speed is zero as detected by the CAN ECU,
- Generator AC Voltage and Frequency must be zero,
- Engine Charge Alternator Voltage must be zero, and
- Oil pressure sensor must indicate low oil pressure.

When the engine has stopped and the module is in the **Stop/Reset Mode**, it is possible to send configuration files to the module from DSE Configuration Suite PC software and to enter the Front Panel Editor to change parameters.

Any latched alarms that have been cleared are reset when **Stop/Reset Mode** is entered.

The engine is not started when in **Stop/Reset Mode**. If start signals are given, the input is ignored until **Auto Mode** is entered.

When the unit is configured for 'Power Save Mode' and has been left in **Stop/Reset Mode** with no presses of the fascia buttons, the module enters Power Save Mode. To 'wake' the module, press any fascia control buttons or activate Digital Input A. The same is true for Deep Sleep Mode.

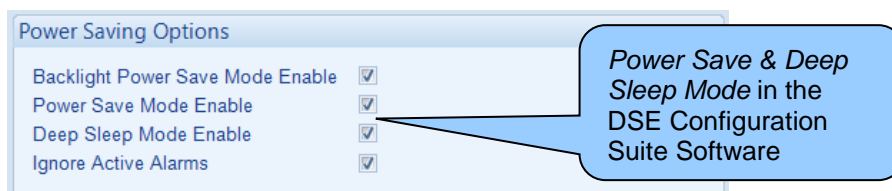

5.3 AUTOMATIC MODE

 **NOTE:** If a digital input configured to *External Panel Lock* is active, changing module modes is not possible. Viewing the instruments and event logs is NOT affected by *Panel Lock*.

Auto Mode is activated by pressing the **Auto Mode**  button.

Auto Mode  allows the generator to operate fully automatically, starting and stopping as required with no user intervention.

5.3.1 WAITING IN AUTO MODE

If a starting request is made, the starting sequence begins. Starting requests can be from the following sources:

- Failure of mains supply,
- Activation of the inbuilt exercise scheduler,
- Activation of an auxiliary input that has been configured to *Remote Start On Load* or *Remote Start Off Load*, or
- Activation of an auxiliary input that has been configured to *Auxiliary Mains Fail*.

5.3.2 STARTING SEQUENCE

 **NOTE:** If the unit has been configured for CAN, compatible ECUs receive the start command via CAN and transmit the engine speed to the DSE controller.

 **NOTE:** For further details of module configuration, refer to DSE Publication: *057-378 DSEG4500 & DSEG4501 Configuration Suite Software Manual*.

To allow for 'false' start requests, the *Start Delay Timer* begins.

The unit returns to a stand-by state if all start requests are removed during the *Start Delay Timer*.

If a start request is still present at the end of the *Start Delay Timer*, the fuel relay is energised, and the engine is started.

If the engine fails to fire during this starting attempt, then the starter motor is disengaged for the *Crank Rest* duration after which the next start attempt is made. If this sequence continues beyond the set *Number of Attempts*, the start sequence is terminated, and the display shows *Fail to Start*.

The starter motor is disengaged when the engine fires. Speed detection is factory configured to be derived from the AC alternator output frequency but can additionally be read from the CANbus link to the engine ECU depending on module configuration.

Additionally, rising oil pressure can be used to disconnect the starter motor (but cannot detect underspeed or overspeed).

After the starter motor has disengaged, the *Safety On Delay* timer activates, allowing Oil Pressure, High Engine Temperature, Under-speed, Charge Fail and any delayed Auxiliary fault inputs to stabilise without triggering the fault.

5.3.3 ENGINE RUNNING

 **NOTE: The load transfer signal remains inactive until the generator is available. This prevents excessive wear on the engine and alternator.**

The generator is placed on load if configured to do so.

If all start requests are removed, the *Stopping Sequence* begins.

5.3.4 STOPPING SEQUENCE

The *Return Delay* timer operates to ensure that the starting request has been permanently removed and is not just a short term removal. If another start request is made during the cooling down period, the set returns on load.

If there are no starting requests at the end of the *Return Delay* timer, the load is transferred from the generator to the mains supply and the *Cooling Down* timer is initiated.

The *Cooling Down* timer allows the set to run off load and cool sufficiently before being stopped. This is particularly important where turbo chargers are fitted to the engine.

After the *Cooling Down* timer has expired, the set is stopped.

5.4 MANUAL/START MODE



NOTE: If a digital input configured to Panel Lock is active, changing module modes is not possible. Viewing the instruments and event logs is NOT affected by Panel Lock.

To begin the starting sequence, press the **Manual/Start Mode**  button. If *Protected Start* is disabled, the start sequence begins immediately.

5.4.1 WAITING IN MANUAL MODE

NOTE: For further details of module configuration, refer to DSE Publication: *057-378 DSEG4500 & DSEG4501 Configuration Suite Software Manual*.

If *Protected Start* is enabled, the LED above the **Manual/Start Mode**  button flashes to indicate **Waiting in Manual Mode**.

The **Manual/Start Mode**  button must be pressed once more, within the *Protected Start Timer*, to begin the start sequence. If the *Protected Start Timer* expires before the **Manual/Start Mode**  button is pressed again, the module reverts to **Stop/Reset Mode** .

Protected Start Mode

Protected Start Mode setting in the DSE Configuration Suite Software

5.4.1.1 ECU OVERRIDE

If *ECU Override During Protected Start* is enabled, pressing the **Manual/Start Mode**  button once powers up the engine's ECU but does not start the engine. This can be used to check the status of the CAN communication and to prime the fuel system.

The *ECU Override* is active for the Duration of the *Protected Start Timer*.

ECU Override During Protected Start

ECU Override During Protected Start setting in the DSE Configuration Suite Software

5.4.2 STARTING SEQUENCE

 **NOTE:** There is no *Start Delay* in this mode of operation.

 **NOTE:** If the unit has been configured for CAN, compatible ECUs receives the start command via CAN.

 **NOTE:** For further details of module configuration, refer to DSE Publication: *057-378 DSEG4500 & DSEG4501 Configuration Suite Software Manual*.

The fuel relay is energised, and the engine is started.

If the engine fails to fire during this starting attempt, then the starter motor is disengaged for the *Crank Rest Timer* duration after which the next start attempt is made. If this sequence continues beyond the set *Number of Attempts*, the start sequence is terminated, and the display shows *Fail to Start*.

The starter motor is disengaged when the engine fires. Speed detection is factory configured to be derived from the AC alternator output frequency but can additionally be read from the CANbus link to the engine ECU depending on module configuration.

Additionally, rising oil pressure can be used to disconnect the starter motor (but cannot detect underspeed or overspeed).

After the starter motor has disengaged, the *Safety On Delay* timer activates, allowing Oil Pressure, High Engine Temperature, Under-speed, Charge Fail and any delayed Auxiliary fault inputs to stabilise without triggering the fault.



5.4.3 ENGINE RUNNING

 **NOTE: The load transfer signal remains inactive until the generator is available. This prevents excessive wear on the engine and alternator.**

In **Manual/Start Mode** , the load is not transferred to the generator unless a 'loading request' is made. A loading request can come from several sources:



- Failure of mains supply,
- Activation of an auxiliary input that has been configured to *Remote Start On Load or Transfer to Generator, Open Mains*,
- Activation of an auxiliary input that has been configured to *Auxiliary Mains Fail*, or
- Activation of the inbuilt exercise scheduler if configured for 'on load' runs.

Once the generator has been placed on load, it is not automatically removed. To manually remove the load either:

- Activate an auxiliary input that has been configured to *Transfer to Mains, Open Generator*,
- Press the **Auto Mode**  button to return to automatic mode. - the set observes all **Auto Mode**  start requests and stopping timers before beginning the *Auto Mode Stopping Sequence*,
- Press the **Stop/Reset Mode**  button to remove load and stop the generator, or
- Activate an auxiliary input that has been configured to *Generator Load Inhibit*.

5.4.4 STOPPING SEQUENCE

In **Manual/Start Mode** , the set continues to run until either:

- The **Stop/Reset Mode**  button is pressed - the delayed load outputs are de-activated immediately and the set immediately stops, or
- The **Auto Mode**  button is pressed - the set observes all **Auto Mode**  start requests and stopping timers before beginning the *Auto Mode Stopping Sequence*.

5.5 FAILSAFE MODE

Failsafe Mode has been implemented to ensure essential operations can continue even if the application code encounters issues. This mode executes the minimum necessary code to facilitate file transfers, including file writes and Device Firmware Update (DFU) processes. It is designed to override any obstacles that may prevent these actions within the application code.

Capabilities in Failsafe Mode:

- Update the configuration file.
- Update the language file.
- Update the engine file.
- Perform a DFU update on the module.

To enter *Failsafe Mode*, press and hold the **Stop/Reset Mode**  and **Manual/Start Mode**  buttons while powering up the module.

When *Failsafe Mode* is activated, the LEDs next to these buttons light up and remain on even after the buttons are released.

The screen remains blank, and the backlight is turned off.

5.6 SCHEDULER

The controller contains an inbuilt exercise run scheduler, capable of automatically starting and stopping the set. Up to 8 scheduled start/stop sequences can be configured to repeat on a 7-day or 28-day cycle.

Scheduled runs may be on load or off load depending upon module configuration.

Example

Screen capture from DSE Configuration Suite Software showing the configuration of the Exercise Scheduler.

In this example the set starts at 09:00 on Monday and run for 5 hours, then start at 13:30 on Tuesday and run for 30 minutes.

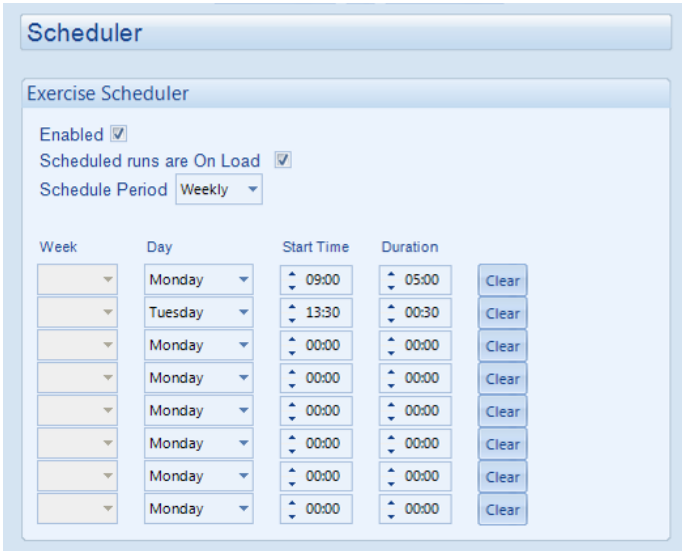



Week	Day	Start Time	Duration	
	Monday	09:00	05:00	Clear
	Tuesday	13:30	00:30	Clear
	Monday	00:00	00:00	Clear
	Monday	00:00	00:00	Clear
	Monday	00:00	00:00	Clear
	Monday	00:00	00:00	Clear
	Monday	00:00	00:00	Clear
	Monday	00:00	00:00	Clear





5.6.1 STOP MODE

- Scheduled runs do not occur when the module is in **Stop/Reset Mode** .

5.6.2 MANUAL MODE

- Scheduled runs do not occur when the module is in **Manual/Start Mode**  waiting for a start request.
- If a Scheduled Run configured as *On Load* is activated while the module is running *Off Load* in **Manual/Start Mode** , the generator will switch to run *On Load*.

5.6.3 AUTO MODE

- Scheduled runs operate only if the module is in **Auto Mode**  with no *Shutdown* or *Electrical Trip* alarm active.
- If the module is in **Stop/Reset Mode**  or **Manual/Start Mode**  when a scheduled run begins, the engine is not started. However, if the module is moved into **Auto Mode**  during a scheduled run, the engine is called to start.
- Depending upon configuration by the system designer, an external input can be used to inhibit a scheduled run.
- If the engine is running *Off Load* in **Auto Mode**  and a scheduled run configured to 'On Load' begins, the set is placed *On Load* for the duration of the Schedule.

5.7 ALTERNATIVE CONFIGURATIONS

Depending upon the configuration of the system by the generator supplier, the system may have selectable configurations (for example to select between 50 Hz and 60 Hz). If this has been enabled the generator supplier will advise how this selection can be made (usually by operating an external selector switch or by selecting the required configuration file in the module's front panel configuration editor).

6 PROTECTIONS

6.1 ALARMS

An icon is displayed in the **Alarm Icon** section to indicate the alarm that is currently active on the controller.



In the event of a warning alarm, the LCD only displays the **Alarm Page**. In the event of an electrical trip or shutdown alarm, the module displays the **Alarm Page** and the **Stop/Reset Mode**  button LED begins to flash.

If multiple alarms are active at the same time, the **Alarm Page** lists all the active alarms which can be scrolled using the the  (up) or  (down) buttons

Example:

If the DSE controller was sensing a charge alternator failure alarm, delay overcurrent alarm and an AC under voltage alarm at the same time, it would cycle through all the icons to show this.



Scroll through the alarm pages on the display by repeatedly operating the up  or down  navigation buttons.

6.1.1 WARNING ALARMS

Warnings are non-critical alarm conditions and do not affect the operation of the engine system, they serve to draw the operator's attention to an undesirable condition.

By default, warning alarms are self-resetting when the fault condition is removed. However, enabling *All Warnings Are Latched* causes warning alarms to latch until reset manually. This is enabled using the DSE Configuration Suite in conjunction with a compatible PC.

Fault	Description
Air Filter Maintenance Alarm	Maintenance due for air filter
Analogue Input Configured As Digital	The analogue inputs can be configured to digital inputs. The module detects that an input configured to create a fault condition has become active.
Analogue Input High	The module detects that an analogue input has risen above the high pre-alarm setting level.
Analogue Input Low	The module detects that an analogue input has fallen below the low pre-alarm setting level.
Auxiliary Inputs	The module detects that an auxiliary input which has been user configured to create a fault condition has become active.
Battery Over Voltage	The DC supply has risen above the high volts pre-set pre-alarm setting.
Battery Under Voltage	The DC supply has fallen below or risen above the low volts pre-set pre-alarm setting.
CAN Data Fail	The module is configured for CAN operation and does not detect data on the engine CAN data link.
CAN ECU Fault	The engine ECU has detected an alarm
Charge Failure	The auxiliary charge alternator voltage is low as measured from the W/L terminal.
Configurable CAN Instrument 1 to 10	The relevant CAN Function has triggered an alarm.
Coolant Level Alarm	The coolant level has been detected as low.
DEF Level	The engine ECU has detected that the DEF level is low.
Delayed Overcurrent	The measured current has risen above the configured trip level for a configured duration.
DPTC Filter	The engine ECU has detected that the DPF regen is required. Contact the engine manufacturer for further details.
ECU Amber	The module received an amber fault condition from the engine ECU.
ECU Malfunction	The module received a malfunction fault condition from the engine ECU.
ECU Protect	The module received a protect fault condition from the engine ECU.
ECU Red	The module received a red fault condition from the engine ECU.
Engine High Temperature	The module detects that the engine coolant temperature has exceeded the high engine temperature pre-alarm setting level after the Safety On timer has expired.

Parameter descriptions are continued overleaf...

Protections

Fault	Description
Fail To Stop	<p>The module has detected a condition that indicates that the engine is running when it has been instructed to stop.</p> <div style="border: 3px double black; padding: 5px;"> <p> NOTE: 'Fail to Stop' could indicate a faulty oil pressure sensor. If engine is at rest check oil sensor wiring and configuration.</p> </div>
Fan Speed Low	The module has detected that the cooling fan speed is too low.
Fuel Filter Maintenance Alarm	Maintenance due for fuel filter.
Fuel Usage Alarm	The module has detected that the fuel consumption is higher than expected.
Gen Over Frequency IEEE C37.2 – 81 Frequency Relay	The module detected that the generator output frequency had risen above the <i>Over Frequency Pre-Alarm Trip</i> level for the configured delay timer.
Gen Over Frequency Delayed IEEE C37.2 – 81 Frequency Relay	The module detected that the generator output frequency had risen above the <i>Over Frequency Trip</i> level but was below the <i>Over Frequency Overshoot Trip</i> for the configured <i>Overshoot Delay</i> timer during starting.
Gen Over Voltage IEEE C37.2 – 59 AC Overvoltage Relay	The module detected that the generator output voltage had risen above the <i>Over Voltage Pre-Alarm Trip</i> level for the configured delay timer.
Gen Under Frequency IEEE C37.2 – 81 Frequency Relay	The module detected that the generator output frequency had fallen below the <i>Under Frequency Pre-Alarm Trip</i> level for the configured delay timer after the <i>Safety On Delay</i> timer had expired.
Gen Under Voltage IEEE C37.2 – 27 AC Undervoltage Relay	The module detected that the generator output voltage had fallen below the <i>Under Voltage Pre-Alarm Trip</i> level for the configured delay timer after the <i>Safety On Delay</i> timer had expired.
HEST Active	The engine ECU has detected that exhaust gas recirculation temperature is high.
High Fuel Level	The level detected by the fuel level sensor is above the high fuel level pre-set pre-alarm setting.
Immediate Overcurrent	The measured current has risen above the configured trip level.
kW Overload IEEE C37.2 – 32 Directional Power Relay	The module detected that the generator output kW had risen above the <i>Overload Protection Trip</i> for the configured delay timer
Load Unbalance	The module detected that there was an imbalance of current across the generator phases greater than the Load Unbalance Trip Level percentage setting.
Low Fuel Level	The level detected by the fuel level sensor is below the low fuel level pre-set pre-alarm setting.
Low Battery Start	The module detected a low battery voltage threshold has been reached when the generator started and the battery needs attention.
Oil Filter Maintenance Alarm	Maintenance due for oil filter.
SCR Inducement	The engine ECU has detected that there is a fault with the SCR system. Contact the engine manufacturer for further details.
Tank Bund Level High	The module has detected that the fuel has leaked in the bund of the fuel tank.
Water In Fuel	The module or engine ECU has detected there is water in the fuel.

6.1.2 ELECTRICAL TRIP ALARMS

NOTE: The fault condition must be resolved before the alarm can be reset. If the fault condition remains, it is not possible to reset the alarm (the exception to this is the *Coolant Temp High* alarm and similar *Active From Safety On* alarms, as the coolant temperature could be high with the engine at rest).

Electrical Trip Alarms are latching and stop the Generator but in a controlled manner. On initiation of the electrical trip condition the module de-activates the **Close Gen Output** outputs to remove the load from the generator. Once this has occurred the module starts the *Cooling Timer* and allows the engine to cool off-load before shutting down the engine. To restart the generator the fault must be cleared, and the alarm reset.

Electrical Trip Alarms are latching alarms and to remove the fault, press the **Stop/Reset Mode**  button on the module.

Fault	Description
Analogue Input Configured As Digital	The analogue inputs can be configured to digital inputs. The module detects that an input configured to create a fault condition has become active.
Analogue Input High	The module detects that an analogue input has risen above the high alarm setting level.
Analogue Input Low	The module detects that an analogue input has fallen below the low alarm setting level.
Analogue Input Open Circuit	The analogue input has been detected as being open circuit.
Auxiliary Inputs	The module detects that an auxiliary input which has been user configured to create a fault condition has become active.
Configurable CAN Instrument 1 to 10	The relevant CAN Function has triggered an alarm.
Coolant Level Alarm	The coolant level has been detected as low.
DEF Level	The engine ECU has detected that the DEF level is low.
Delayed Overcurrent	The measured current has risen above the configured trip level for a configured duration.
DPTC Filter	The engine ECU has detected that the DPF regen is required. Contact the engine manufacturer for further details.
ECU Amber	The module received an amber fault condition from the engine ECU.
ECU Malfunction	The module received a malfunction fault condition from the engine ECU.
ECU Protect	The module received a protect fault condition from the engine ECU.
ECU Red	The module received a red fault condition from the engine ECU.

Parameter descriptions are continued overleaf...

Protections

Fault	Description
Fan Speed Low	The module has detected that the cooling fan speed is too low.
Fuel Usage Alarm	The module has detected that the fuel consumption is higher than expected.
High Fuel Level	The level detected by the fuel level sensor is above the high fuel level pre-set alarm setting.
kW Overload IEEE C37.2 – 32 Directional Power Relay	The module detected that the generator output kW had risen above the <i>Overload Protection Trip</i> for the configured delay timer
Load Unbalance	The module detected that there was an imbalance of current across the generator phases greater than the <i>Load Unbalance Trip Level</i> percentage setting.
Low Fuel Level	The level detected by the fuel level sensor is below the low fuel level pre-set alarm setting.
SCR Inducement	The engine ECU has detected that there is a fault with the SCR system. Contact the engine manufacturer for further details.
Tank Bund Level High	The module has detected that the fuel has leaked in the bund of the fuel tank.
Water In Fuel	The module or engine ECU has detected there is water in the fuel.

6.1.3 SHUTDOWN ALARMS

 **NOTE:** The fault condition must be resolved before the alarm can be reset. If the fault condition remains, it is not possible to reset the alarm (the exception to this is the *Oil Pressure Low* alarm and similar *Active From Safety On* alarms, as the oil pressure is low with the engine at rest).

Shutdown Alarms are latching and immediately stop the Generator. On initiation of the shutdown condition the module de-activates the **Close Gen Output** outputs to remove the load from the generator. Once this has occurred, the module shuts the generator set down immediately to prevent further damage. To restart the generator the fault must be cleared, and the alarm reset.

Shutdown Alarms are latching alarms and to remove the fault, press the **Stop/Reset Mode**  button on the module.

Fault	Description
Air Filter Maintenance Alarm	Maintenance due for air filter
Analogue Input Configured As Digital	The analogue inputs can be configured to digital inputs. The module detects that an input configured to create a fault condition has become active.
Analogue Input High	The module detects that an analogue input has risen above the high alarm setting level.
Analogue Input Low	The module detects that an analogue input has fallen below the low alarm setting level.
Analogue Input Open Circuit	The analogue input has been detected as being open circuit.
Auxiliary Inputs	The module detects that an auxiliary input which has been user configured to create a fault condition has become active.
CAN Data Fail	The module is configured for CAN operation and does not detect data on the engine CAN data link.
CAN ECU Fault	The engine ECU has detected an alarm – CHECK ENGINE LIGHT Contact Engine Manufacturer for support.
Charge Failure	The auxiliary charge alternator voltage is low as measured from the W/L terminal.
Configurable CAN Instrument 1 to 10	The relevant CAN Function has triggered an alarm.
Coolant Level Alarm	The coolant level has been detected as low.
Coolant Level Sensor Open Circuit	The coolant level sensor has been detected as being open circuit.
Coolant Temperature Sensor Open Circuit	The coolant temperature sensor has been detected as being open circuit.
Coolant Temp High IEEE C37.2 – 26 Apparatus Thermal Device	The module detected that the engine coolant temperature had risen above the <i>High Coolant Temperature Shutdown Trip</i> level after the <i>Safety On Delay</i> timer had expired.
Coolant Temp High Switch IEEE C37.2 – 26 Apparatus Thermal Device	The module detected that the high engine coolant temperature switch had activated after the <i>Safety On Delay</i> timer had expired.
DEF Level	The engine ECU has detected that the DEF level is low.
Delayed Overcurrent	The measured current has risen above the configured trip level for a configured duration.

Parameter descriptions are continued overleaf...

Protections

Fault	Description
DPTC Filter	The engine ECU has detected that the DPF regen is required. Contact the engine manufacturer for further details.
ECU Amber	The module received an amber fault condition from the engine ECU.
ECU Malfunction	The module received a malfunction fault condition from the engine ECU.
ECU Protect	The module received a protect fault condition from the engine ECU.
ECU Red	The module received a red fault condition from the engine ECU.
Emergency Stop IEEE C37.2 - 5 Stopping Device	The module detected that emergency stop button had been pressed removing a positive voltage supply from the emergency stop input terminal. This input is failsafe (normally closed to emergency stop) and immediately stops the generator when the signal is removed.
Engine High Temperature	The module detects that the engine coolant temperature has exceeded the high engine temperature pre-alarm setting level after the Safety On timer has expired.
Engine Over Speed IEEE C37.2 - 12 Overspeed Device	The module detected that the engine speed had risen above the <i>Over Speed Alarm Trip</i> level for the configured delay timer.
Failed to Start IEEE C37.2 - 48 Incomplete Sequence Relay	The module detected that the generator had failed to start as it did not meet the required Crank Disconnect criteria during the configured number of Crank Attempts.
Failed to Stop IEEE C37.2 - 48 Incomplete Sequence Relay	 NOTE: Fail to Stop could indicate a faulty oil pressure sensor. If engine is at rest, check the oil pressure sensor wiring and configuration.
	The module detects a condition that indicates the generator is running when the DSE module has instructed it to stop.
Fan Speed Low	The module detected that the cooling fan speed is too low.
Fuel Filter Maintenance Alarm	Maintenance due for fuel filter.
Fuel Level High IEEE C37.2 - 71 Liquid Level Switch	The module detected that the engine fuel level had risen the <i>High Fuel Level Alarm</i> level for the configured delay.
Fuel Level Low IEEE C37.2 - 71 Liquid Level Switch	The module detected that the engine fuel level had fallen below the <i>Low Fuel Level Alarm</i> level for the configured delay
Fuel Level Low Switch IEEE C37.2 - 71 Liquid Level Switch	The module detected that the engine low fuel level switch had activated.
Fuel Usage IEEE C37.2 - 80 Flow Switch	The module detected that the fuel consumption was more than the configured <i>Running Rate</i> or <i>Stopped Rate</i> .
Gen Over Frequency IEEE C37.2 - 81 Frequency Relay	The module detected that the generator output frequency had risen above the <i>Over Frequency Pre-Alarm Trip</i> level for the configured delay timer.
Gen Over Voltage IEEE C37.2 - 59 AC Overvoltage Relay	The module detected that the generator output voltage had risen above the <i>Over Voltage Pre-Alarm Trip</i> level for the configured delay timer.
Gen Under Frequency IEEE C37.2 - 81 Frequency Relay	The module detected that the generator output frequency had fallen below the <i>Under Frequency Pre-Alarm Trip</i> level for the configured delay timer after the <i>Safety On Delay</i> timer had expired.
Gen Under Voltage IEEE C37.2 - 27 AC Undervoltage Relay	The module detected that the generator output voltage had fallen below the <i>Under Voltage Pre-Alarm Trip</i> level for the configured delay timer after the <i>Safety On Delay</i> timer had expired.

Parameter descriptions are continued overleaf...

Protections

Fault	Description
kW Overload IEEE C37.2 – 32 Directional Power Relay	The module detected that the generator output kW had risen above the <i>Overload Protection Trip</i> for the configured delay timer
Load Unbalance	The module detected that there was an imbalance of current across the generator phases greater than the Load Unbalance Trip Level percentage setting.
Low Fuel Level	The level detected by the fuel level sensor is below the low fuel level pre-set alarm setting.
Low Oil Pressure	The module detects that the engine oil pressure has fallen below the low oil pressure pre-alarm setting level after the Safety On timer has expired.
Oil Filter Maintenance Alarm	Maintenance due for oil filter.
Oil Sensor Open Circuit	The oil pressure sensor has been detected as being open circuit.
Over Speed	The engine speed has risen above the over speed pre alarm setting
SCR Inducement	The engine ECU has detected that there is a fault with the SCR system. Contact the engine manufacturer for further details.
Tank Bund Level High	The module has detected that the fuel has leaked in the bund of the fuel tank.
Under Speed	The engine speed has fallen below the under speed pre alarm setting
Water In Fuel	The module or engine ECU has detected there is water in the fuel.

6.1.4 MAINTENANCE ALARMS

Depending upon module configuration, one or more levels of engine maintenance alarm may occur based upon a configurable schedule.

Example 1

Screen capture from DSE Configuration Suite Software showing the configuration of the Maintenance Alarm for Oil, Air and Fuel.

When activated, the maintenance alarm can be either a **warning** (set continues to run) or **shutdown** (running the set is not possible).

Resetting the maintenance alarm is normally actioned by the site service engineer after performing the required maintenance.

The method of reset is either by:

- Activating an input that has been configured to Maintenance Reset Alarm x, where x is the type of maintenance alarm (Oil, Air or Fuel).
- Pressing the maintenance reset button in the DSE Configuration Suite, Maintenance section.
- Pressing and holding the **Stop/Reset Mode**  button for 10 seconds on the desired Maintenance Alarm status page. This can be protected by a PIN.

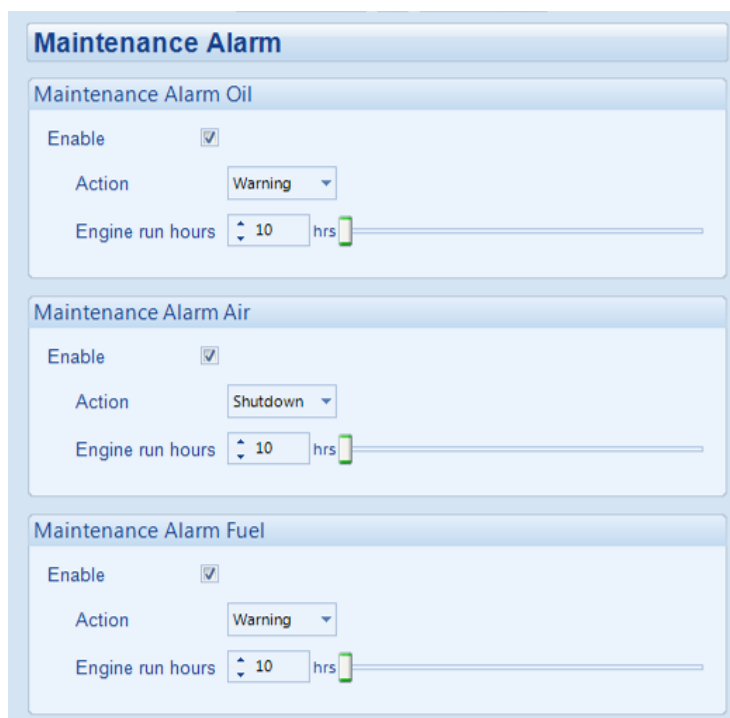

Example 2

Screen capture from DSE Configuration Suite Software showing the configuration of a digital input for Maintenance Reset Alarm Air.

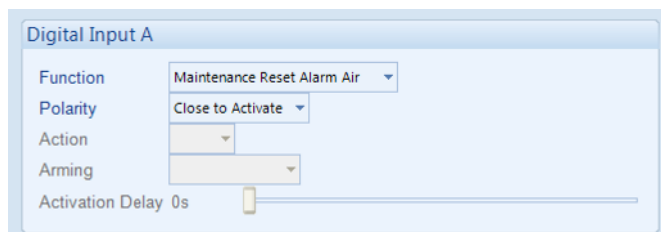

Example 3

Screen capture from DSE Configuration Suite Software showing the Maintenance Alarm Reset 'button' in the DSE Configuration Suite SCADA | MAINTENANCE section.

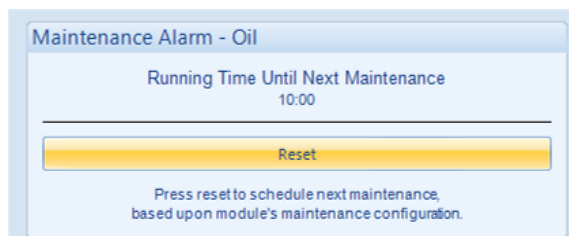

7 FRONT PANEL CONFIGURATION

This configuration mode allows the operator to configure most of the module through its display without the use of the DSE Configuration Suite PC Software.

Use the module's facia buttons to traverse the menu and make value changes to the parameters.



7.1 FRONT PANEL EDITOR

7.1.1 FRONT PANEL EDITOR DISPLAY

The Front Panel Editor (FPE) is organized into pages of screens that contain related configurable items. The page item displayed on the title bar is the FPE page icon; however, the page string in the title bar and the leftmost page icon in the menu bar (which will always be visible in the FPE) changes to reflect the currently selected FPE page.

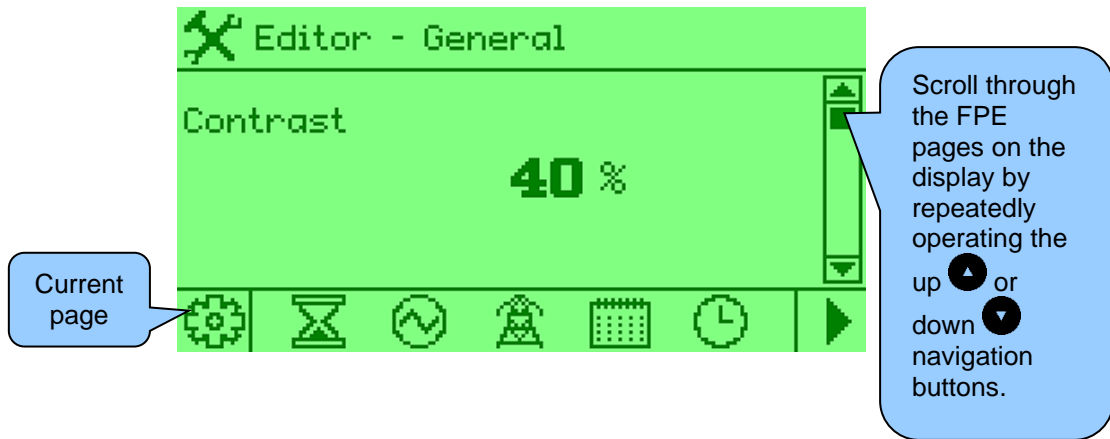

When viewing an FPE item, the tick button can be utilized to select the item for editing. Once selected, the item's value will flash to indicate that it is in the editing mode. At this stage, the (+) and (-) buttons can be used to increment or decrement the value.

The tick button (✓) may then be used again to complete the editing process.



7.1.2 ACCESSING THE FRONT PANEL EDITOR







 **NOTE:** More comprehensive module configuration is possible via PC configuration software. For further details of module configuration, refer to DSE Publication: 057-378 *DSEG4500 & DSEG4501 Configuration Suite Software Manual*.

- Ensure the engine is at rest by pressing the **Stop/Reset Mode**  button.
- Press and hold the **Stop/Reset Mode**  (-) and **Auto Mode**  (✓) buttons together to enter the main configuration editor.

7.1.3 ENTERING PIN

 **NOTE:** The PIN is not set by DSE when the module leaves the factory. If the module has a PIN code set, the generator supplier has entered this. Contact the generator supplier if the code is required. If the code has been 'lost' or 'forgotten', the module must be returned to the DSE factory to have the PIN removed. A charge is made for this procedure. This procedure cannot be performed away from the DSE factory.









 **NOTE:** The PIN is automatically reset when the editor is exited (manually or automatically) to ensure security.

- If a module security PIN has been set, the PIN request is then shown.
- Press the **Auto Mode**  (✓) button, the first '#' changes to '0'. Press the **Up**  or **Down**  buttons to adjust it to the correct value.
- Press the **Manual/Start Mode**  (+) buttons to move to the next digit. The digit previously entered now shows as '#' for security.
- Repeat this process for the other digits of the PIN number. Press the **Stop/Reset Mode**  (-) button to move back to adjust one of the previous digits.
- When the **Auto Mode**  (✓) button is pressed after editing the final PIN digit, the PIN is checked for validity. If the number is not correct, the display will return to the Home page.
- If the PIN has been successfully entered (or the module PIN has not been enabled), the editor is displayed.

7.1.4 EDITING A PARAMETER



 **NOTE:** Pressing and holding the *Stop/Reset Mode*  (-) or *Manual/Start Mode*  (+) buttons enables an auto-repeat functionality.

 **NOTE:** In addition to the standard navigation, the module includes a configurable *Page Change Delay* feature. If no buttons are pressed within the set timeout period, the screen will automatically return to the Home page. By default, the timeout is set to 10 seconds, but this can be adjusted as needed.

- Once in the selected editor, press the *Up*  and *Down*  navigation buttons to cycle through various pages (General, Timers, Generator, etc.).
- Press the *Stop/Reset Mode*  (-) or *Manual/Start Mode*  (+) buttons to cycle through the editor in increments of 1.
- When viewing the parameter to be edited, press the *Auto Mode*  (✓) button, the value begins to flash.
- Press the *Stop/Reset Mode*  (-) or *Manual/Start Mode*  (+) buttons to adjust the value to the required setting.
- Press the *Auto Mode*  (✓) button to save the current value, the value ceases flashing.

7.1.5 EXITING THE MAIN CONFIGURATION EDITOR

 **NOTE:** The editor automatically exits after 5 minutes of inactivity to ensure security.

- Press and hold the *Stop/Reset Mode*  (-) button to exit the editor without saving changes.
- Press and hold the *Auto Mode*  (✓) button to exit the editor and save the changes.

7.1.6 FRONT PANEL EDITOR PARAMETERS

	Functionality in DSEG4500 & DSEG4501 Remote Start and AMF
	Functionality in DSEG4500 & DSEG4501 AMF Only

Section	Parameter As Shown On Display	Values
General	Contrast	0 (%)
	Language	English, Other.
	Pressure Units	0 (0 = kPa, 1 = bar, 2 = psi)
	Temperature Units	0 (0 = C, 1 = F)
	Volume Units	0 (0 = L, 1 = gal, 2 = USgal)
	Fast Loading Enabled	On (1), Off (0)
	All Warnings Latched	On (1), Off (0)
	Lamp Test At Startup	On (1), Off (0)
	Power Save Mode Enable	On (1), Off (0)
	Deep Sleep Mode Enable	On (1), Off (0)
	Protected Start Enable	On (1), Off (0)
	Event Log Display Format	On (1), Off (0)
	Power Up Mode	0 (Power Up Mode)
	DTC String Enable	On (1), Off (0)
	PIN Protected Maintenance Reset	On (1), Off (0)
	Stop Button Cool Down	On (1), Off (0)
	Backlight Inactivity Enable	On (1), Off (0)
	ECU Periodic Wakeup Enabled	On (1), Off (0)
	Limit Audible Alarm Duration	On (1), Off (0)
	ECU Override During Protected Enable	On (1), Off (0)
Timers	Mains Transient Delay	0 s
	Start Delay	hh:mm:ss
	Preheat Timer	hh:mm:ss
	Crank Time	0.0 s
	Crank Rest Time	0 s
	Smoke Limiting	hh:mm:ss
	Smoke Limiting Off	0 s
	DPF Ramp	0 s
	Safety On Delay	0 s
	Warm Up Time	hh:mm:ss
	Return Delay	hh:mm:ss
	Cooling Time	hh:mm:ss
	ETS Solenoid Hold	hh:mm:ss
	Failed To Stop Delay	hh:mm:ss
	Transfer Delay	0.0 s
	Breaker Trip Pulse	0.0 s
	Breaker Close Pulse	0.0 s
	Delayed Load Output 1	hh:mm:ss
	Delayed Load Output 2	hh:mm:ss
	Delayed Load Output 3	hh:mm:ss
	Delayed Load Output 4	hh:mm:ss
	Power Save Mode Delay	hh:mm:ss
	Deep Sleep Mode Delay	hh:mm:ss
	Page Delay	hh:mm:ss
	Page Change Delay	0 s
	Cooling Time at Idle	hh:mm:ss
	Backlight Power Save Delay	hh:mm:ss
	Audible Alarm Timer	0 s
	Fuel Pull in Coil Duration	0.0 s

Parameter descriptions are continued overleaf...

Front Panel Configuration

Section	Parameter As Shown On Display	Values
	ECU Override Time	hh:mm:ss
	ECU Periodic Wakeup Period	hh:mm:ss
Timers	Post-Heat Timer	0 s
	Delay Crank Timer	0.0 s
	Max Start Pause Time	0.0 s
	Engage Attempt Time	0.0 s
	Engage Rest Time	0.0 s
	Protected Start Timeout	hh:mm:ss
	Exhaust Temperature Based Cooling Time	hh:mm:ss
Generator	Under Voltage Shutdown Enable	On (1), Off (0)
	Under Voltage Trip Shutdown	0 V
	Under Voltage Warning Enable	On (1), Off (0)
	Under Voltage Warning Trip	0 V
	Under Voltage Activation Delay	0.0 s
	Loading Voltage	0 V
	Nominal Voltage	0 V
	Over Voltage Warning Enable	On (1), Off (0)
	Over Voltage Warning Return	0 V
	Over Voltage Warning Trip	0 V
	Over Voltage Shutdown Trip	0 V
	Over Voltage Activation Delay	0.0 s
	Under Frequency Shutdown Enable	On (1), Off (0)
	Under Frequency Shutdown Trip	0.0 Hz
	Under Frequency Warning Enable	On (1), Off (0)
	Under Frequency Warning Trip	0.0 Hz
	Under Frequency Activation Delay	0.0 s
	Loading Frequency	0.0 Hz
	Nominal Frequency	0.0 Hz
	Over Frequency Warning Enable	On (1), Off (0)
	Over Frequency Warning Return	0.0 Hz
	Over Frequency Warning Trip	0.0 Hz
	Over Frequency Shutdown Enable	On (1), Off (0)
	Over Frequency Shutdown Trip	0.0 Hz
	Over Frequency Activation Delay	0.0 s
	Immediate Overcurrent 1 Enable	On (1), Off (0)
	Delayed Overcurrent 1 Alarm Enable	On (1), Off (0)
	Delayed Overcurrent 1 Alarm Action	0 (Action)
	Overcurrent 1 Delay	hh:mm:ss
	Overcurrent 1 Trip	0 %
	Immediate Overcurrent 2 Enable	On (1), Off (0)
	Delayed Overcurrent 2 Alarm Enable	On (1), Off (0)
	Delayed Overcurrent 2 Alarm Action	0 (Action)
	Overcurrent 2 Delay	hh:mm:ss
	Overcurrent 2 Trip	0 %
	kW Rating	0 kW
	Over kW Protection Enable	On (1), Off (0)
	Over kW Protection Action	0 (Action)
	Over kW Protection Trip	0 %
	Over kW Protection Trip Delay	hh:mm:ss
	Over kW Protection Return	0 %
	Load Unbalance Alarm	On (1), Off (0)
	Load Unbalance Alarm Action	0 (Action)
Load Unbalance Trip	0 %	
Load Unbalance Warning Return	0 %	
Load Unbalance Delay Time	0.0 s	

Parameter descriptions are continued overleaf...





Front Panel Configuration

Section	Parameter As Shown On Display	Values
Mains	Mains Failure Detection	On (1), Off (0)
	Immediate Mains Dropout	On (1), Off (0)
	Under Voltage Enable	On (1), Off (0)
	Under Voltage Level	0 V
	Under Voltage Return	0 V
	Over Voltage Enable	On (1), Off (0)
	Over Voltage Return	0 V
	Over Voltage Level Trip	0 V
	Under Frequency Enable	On (1), Off (0)
	Under Frequency Trip	0.0 Hz
	Under Frequency Return	0.0 Hz
	Over Frequency Enable	On (1), Off (0)
	Over Frequency Return	0 Hz
	Over Frequency Trip	0.0 Hz
Scheduler	Enable Scheduler	On (1), Off (0)
	Schedule Run On or Off Load	On (1), Off (0)
	Scheduler Period	Weekly (0), Monthly(1)
	Start Time (Entry 1)	hh:mm
	Day (Entry 1)	0 (1=Monday)
	Week (Entry 1)	1, 2, 3 or 4
	Duration (Entry 1)	hh:mm
	Start Time (Entry 2)	hh:mm
	Day (Entry 2)	0 (1=Monday)
	Week (Entry 2)	1, 2, 3 or 4
	Duration (Entry 2)	hh:mm
	Start Time (Entry 3)	hh:mm
	Day (Entry 3)	0 (1=Monday)
	Week (Entry 3)	1, 2, 3 or 4
	Duration (Entry 3)	hh:mm
	Start Time (Entry 4)	hh:mm
	Day (Entry 4)	0 (1=Monday)
	Week (Entry 4)	1, 2, 3 or 4
	Duration (Entry 4)	0 s
	Start Time (Entry 5)	hh:mm
	Day (Entry 5)	0 (1=Monday)
	Week (Entry 5)	1, 2, 3 or 4
	Duration (Entry 5)	hh:mm
	Start Time (Entry 6)	hh:mm
	Day (Entry 6)	0 (1=Monday)
	Week (Entry 6)	1, 2, 3 or 4
	Duration (Entry 6)	0 s
	Start Time (Entry 7)	hh:mm
	Day (Entry 7)	0 (1=Monday)
	Week (Entry 7)	1, 2, 3 or 4
	Duration (Entry 7)	hh:mm
	Start Time (Entry 8)	hh:mm
Day (Entry 8)	0 (1=Monday)	
Week (Entry 8)	1, 2, 3 or 4	
Duration (Entry 8)	hh:mm	
Date & Time	Time of Day	hh:mm:ss
	Day of Month	1-31
	Month of Year	1-12
	Year	0-99

8 COMMISSIONING

 **NOTE: If Emergency Stop feature is not required, link the input to the DC Negative or disable the input. For further details of module configuration, refer to DSE Publication: 057-378 DSEG4500 & DSEG4501 Configuration Suite Software Manual.**

Before the system is started, it is recommended that the following checks are made:

- The unit is adequately cooled and all the wiring to the module is of a standard and rating compatible with the system. Check all mechanical parts are fitted correctly and that all electrical connections (including earths) are sound.
- The unit DC supply is fused and connected to the battery and that it is of the correct polarity.
- The Emergency Stop input is wired to an external **normally closed** switch connected to **DC negative**.
- To check the start cycle operation, take appropriate measures to prevent the engine from starting (disable the operation of the fuel solenoid). After a visual inspection to ensure it is safe to proceed, connect the battery supply. Press the **Manual/Start Mode**  button, the unit start sequence commences.
- The starter engages and operates for the pre-set start period. After the starter motor has attempted to start the engine for the pre-set number of attempts, the LCD displays **Fail to Start** . Press the **Stop/Reset Mode**  button to reset the unit.
- Restore the engine to operational status (reconnect the fuel solenoid). Press the **Manual/Start Mode**  button. This time the engine is expected to start, and the starter motor is expected to disengage automatically. If not then check that the engine is fully operational (fuel available, etc.) and that the fuel solenoid is operating. The engine must now run up to operating speed. If not, and an alarm is present, check the alarm condition for validity, then check input wiring. The engine is expected to continue running for an indefinite period. It is possible currently to view the engine and alternator parameters - refer to the 'Description of Controls' section of this manual.
- Press the **Auto Mode**  button, the engine runs for the pre-set cooling down period, then stops. The generator is expected to stay in the standby mode. If it does not, check that the *Remote Start* input is not active.
- Initiate an automatic start by supplying the remote start signal (if configured). The start sequence commences, and the engine runs up to operational speed. Once the generator is available the delayed load outputs activate, the Generator accepts the load. If not, check the wiring to the delayed load output contactors. Check the Warming timer has timed out.
- Remove the remote start signal. The return sequence begins. After the pre-set time, the generator is unloaded. The generator then runs for the pre-set cooling down period, then shuts down into its standby mode.
- Set the module's internal clock/calendar to ensure correct operation of the scheduler and event logging functions. For details of this procedure see section entitled *Front Panel Configuration*.
- If, despite repeated checking of the connections between the controller and the customer's system, satisfactory operation cannot be achieved, then contact DSE Technical Support Department. **E-mail:** support@deepseaelectronics.com

9 CAN INTERFACE SPECIFICATION (J1939-75)

The ECU port is used for live operational communications between the DSE module and other CAN enabled devices. The specification below details all broadcast messages which are transmitted when the J1939-75 is enabled, and the relevant engine file is selected.

Parameter	Description
Protocol	SAE J1939 with PGNs as listed in the following subsections.
Bit Rate	250 kb/s
Isolation	± 2.5 kVrms
Termination	120 Ω termination resistor fitted internally.

9.1 BROADCAST MESSAGES J1939-75

 **NOTE:** All instrumentation is transmitted from the DSE module using a default source address of 44 (0x2C), however this is configurable. Refer to the module's configuration for further clarification of the configured source address.

 **NOTE:** Availability of instrumentation changes depends on module type and configuration. For SPNs that are not applicable/configured within a PGN, the module transmits have all bits set to '1'. For PGNs where all SPNs that are not applicable/configured, the module no longer transmits the PGN.

 **NOTE:** All message ID information is shown in a Hexadecimal format.

 **NOTE:** Values larger than 8 bits utilise *Little-Endian* format. For example, a 16 bit value, occupying two Bytes has Byte2 as the most significant Byte and Byte1 as the least significant Byte.

Parameter Groups below are broadcast by the module and are detailed in the following subsections.

9.1.1 INSTRUMENTATION

9.1.1.1 ENGINE

NOTE: When the *Conventional Diesel Plus* engine file is selected (no engine ECU), all the *Engine* instruments are transmitted from the DSE module.

When any other engine file is selected, the *Engine* instruments are not transmitted by the DSE module unless the DSE module is configured to ignore the engine ECU's transmission for that specific instrument.

The *Engine* instrumentation listed in this section is what the DSE module transmits on the CANbus link when *J1939-75 Instrumentation* is enabled in the configuration.

DD1 - Dash Display 1

PGN 65276

Priority	Ext Data Page	Data Page	PDU Format	PDU Specific	Default Source Address	Default Message ID	Transmit Rate
0x6	0x0	0x0	0xFE	0xFC	0x2C (44)	0x18FEFC2C	1000 ms
0x18			0x0FEFC (65276)				

SPN	Instrument	Byte / Bit	Range	Scaling	Offset
96	Engine Fuel Level	Byte 2	0 to 100 %	0.4 %	0

EC2 - Engine Configuration 2

PGN 64895

Priority	Ext Data Page	Data Page	PDU Format	PDU Specific	Default Source Address	Default Message ID	Transmit Rate
0x6	0x0	0x0	0xFD	0x7F	0x2C (44)	0x18FD7F2C	Request
0x18			0x0FD7F (64895)				

SPN	Instrument	Byte / Bit	Range	Scaling	Offset
3670	Maximum Crank Attempts per Start Attempt	Byte 1	0 to 250	1	0

Request Message

Priority	Ext Data Page	Data Page	PDU Format	PDU Specific	Source Address of Requesting Device	Default Message ID
0x6	0x0	0x0	0xEA	0xFF	0x##	0x18FEE5##
0x18						

Byte	Data
1	0x7F (PDU Specific of requested message ID)
2	0xFD (PDU Format of requested message ID)
3	0x00 (Ext Data Page & Data Page of requested message ID)

EEC1- Electronic Engine Controller 1

PGN 61444

Priority	Ext Data Page	Data Page	PDU Format	PDU Specific	Default Source Address	Default Message ID	Transmit Rate
0x3	0x0	0x0	0xF0	0x04	0x2C (44)	0x0CF0042C	100 ms
0x0C							
		0x0F004 (61444)					

SPN	Instrument	Byte / Bit	Range	Scaling	Offset
190	Engine Speed	Byte 4 to 5	0 to 8031.875 RPM	0.125 RPM	0

EEC4 - Electronic Engine Controller 4

PGN 65214

Priority	Ext Data Page	Data Page	PDU Format	PDU Specific	Default Source Address	Default Message ID	Transmit Rate
0x7	0x0	0x0	0xFE	0xBE	0x2C (44)	0x1CFEBE2C	Request
0x1C							
		0x0FEBE (65214)					

SPN	Instrument	Byte / Bit	Range	Scaling	Offset
3671	Crank Attempt Count on Present Start Attempt	Byte 6	0 to 250	1	0

Request Message

Priority	Ext Data Page	Data Page	PDU Format	PDU Specific	Source Address of Requesting Device	Default Message ID
0x6	0x0	0x0	0xEA	0xFF	0x##	0x18FEE5##
0x18						

Byte	Data
1	0xBE (PDU Specific of requested message ID)
2	0xFE (PDU Format of requested message ID)
3	0x00 (Ext Data Page & Data Page of requested message ID)

EFL/P1 – Engine Fluid Level/Pressure 1

PGN 65263

Priority	Ext Data Page	Data Page	PDU Format	PDU Specific	Default Source Address	Default Message ID	Transmit Rate
0x6	0x0	0x0	0xFE	0xEF	0x2C (44)	0x18FEEF2C	500 ms
0x18							
		0x0FEEF (65263)					

SPN	Instrument	Byte / Bit	Range	Scaling	Offset
100	Engine Oil Pressure	Byte 4	0 to 1000 kPa	1 kPa	0

EOI - Engine Operating Information

PGN 64914

Priority	Ext Data Page	Data Page	PDU Format	PDU Specific	Default Source Address	Default Message ID	Transmit Rate
0x3	0x0	0x0	0xFD	0x92	0x2C (44)	0x0CFD922C	250 ms
0x0C							
		0x0FD92 (64914)					

SPN	Instrument	Byte / Bit	State
3543	Engine Operating State	Byte 1 Bits 1 to 4	0000: Stopped (<i>At Rest, Power on Before Start, or Failed to Start</i> are active). 0001: Pre-Start (<i>Fuel or Pre-Heat Timer</i> are active). 0010: Starting (<i>Cranking Timer or Crank Rest Timer</i> is active). 0100: Running (<i>Idle Speed, Rated Speed, Running or Fail to Stop Timer</i> are active). 0101: Stopping (<i>Stopping Timer</i> is active).
3607	Emergency Stop	Byte 6 Bit 5 to 6	00: Off (No Shutdown Requested) 01: On (Shutdown Requested) 10: Reserved 11: Don't care / take no action

ET1 - Engine Temperature 1

PGN 65262

Priority	Ext Data Page	Data Page	PDU Format	PDU Specific	Default Source Address	Default Message ID	Transmit Rate
0x6	0x0	0x0	0xFE	0xEE	0x2C (44)	0x18FEEEE2C	1000 ms
0x18							
		0x0FEEE (65262)					

SPN	Instrument	Byte / Bit	Range	Scaling	Offset
110	Engine Coolant Temperature	Byte 1	-40 to 210 °C	1 °C	-40

HOURS - Engine Hours, Revolutions

PGN 65253

Priority	Ext Data Page	Data Page	PDU Format	PDU Specific	Default Source Address	Default Message ID	Transmit Rate
0x6	0x0	0x0	0xFE	0xE5	0x2C (44)	0x18FEE52C	Request
0x18	0x0FEE5 (65253)						

SPN	Instrument	Byte / Bit	Range	Scaling	Offset
247	Engine Total Hours of Operation	Byte 1 to 4	0 to 210554060.75 hr	0.05 hr	0

Request Message

Priority	Ext Data Page	Data Page	PDU Format	PDU Specific	Source Address of Requesting Device	Default Message ID
0x6	0x0	0x0	0xEA	0xFF	0x##	0x18FEE5##
0x18						

Byte	Data
1	0xE5 (PDU Specific of requested message ID)
2	0xFE (PDU Format of requested message ID)
3	0x00 (Ext Data Page & Data Page of requested message ID)

SOFT - Software Identification (Engine File)

PGN 65242

Priority	Ext Data Page	Data Page	PDU Format	PDU Specific	Default Source Address	Default Message ID	Transmit Rate
0x6	0x0	0x0	0xFE	0xDA	0x2C (44)	0x18FEDA2C	Request
0x18	0x0FEDA (65242)						

SPN	Instrument	Byte / Bit	Range	Scaling	Offset
965	Number of software identification fields	Byte 1	0 to 250	1	0
234	Major Version Number	Byte 2	N/A	1	0
234	Minor Version Number	Byte 3	N/A	1	0
234	Build Version Number	Byte 4	N/A	1	0
234	De-limiter	Byte 5	N/A	1	0

Request Message

Priority	Ext Data Page	Data Page	PDU Format	PDU Specific	Source Address of Requesting Device	Default Message ID
0x6	0x0	0x0	0xEA	0xFF	0x##	0x18FEE5##
0x18						

Byte	Data
1	0xDA (PDU Specific of requested message ID)
2	0xFE (PDU Format of requested message ID)
3	0x00 (Ext Data Page & Data Page of requested message ID)

VEP1 - Vehicle Electrical Power 1

PGN 65271

Priority	Ext Data Page	Data Page	PDU Format	PDU Specific	Default Source Address	Default Message ID	Transmit Rate
0x6	0x0	0x0	0xFE	0xF&	0x2C (44)	0x18FEF72C	1000 ms
0x18							
		0x0FEF7 (65271)					

SPN	Instrument	Byte / Bit	Range	Scaling	Offset
167	Charge Alternator Voltage	Byte 3 to 4	0 to 3212.75 V	0.05 V	0
168	Plant Battery Voltage	Byte 5 to 6	0 to 3212.75 V	0.05 V	0

PROPB 00 - Remote Start Status

PGN 65280

Priority	Ext Data Page	Data Page	PDU Format	PDU Specific	Default Source Address	Default Message ID	Transmit Rate
0x6	0x0	0x0	0xFF	0x00	0x2C (44)	0x18FF002C	250 ms
0x18							
		0x0FF00 (65280)					

SPN	Instrument	Byte / Bit	State
Proprietary	Remote Start Status	Byte 1	No Bits Active: No Remote Start Signal Active Bit 1 Active: Remote Start Off Load is Active Bit 2 Active: Remote Start On Load is Active Bit 3 Active: Remote Start On Load Demand is Active Bit 4 Active: Remote Start in Island Mode is Active Bit 5 to 8: Reserved

9.1.1.2 GENERATOR

NOTE: The *Generator* instrumentation does not change depending on the engine file selected.

The *Generator* instrumentation listed in this section is what the DSE module transmits on the CANbus link when *J1939-75 Instrumentation* is enabled in the configuration.

ACS - AC Switching Device Status

PGN 64913

Priority	Ext Data Page	Data Page	PDU Format	PDU Specific	Default Source Address	Default Message ID	Transmit Rate
0x6	0x0	0x0	0xFD	0x91	0x2C (44)	0x18FD912C	250 ms
0x18			0x0FD91 (64913)				

SPN	Instrument	Byte / Bit	State
3545	Generator Breaker Status	Byte 1 Bits 1 to 3	00: Open 001: Closed 010: Locked Out 011-101: Available for SAE assignment 110: Error 111: Not available

GC1 - Generator Control 1

PGN 64915

Priority	Ext Data Page	Data Page	PDU Format	PDU Specific	Default Source Address	Default Message ID	Transmit Rate
0x6	0x0	0x0	0xFD	0x93	0x2C (44)	0x18FD932C	100 ms
0x18			0x0FD93 (64915)				

SPN	Instrument	Byte / Bit	State
3567	Generator Control Not In Automatic Start State	Byte 1 Bits 5 to 6	00: Inactive (ready to start automatically) 01: Active (not ready to start automatically) 10: Error 11: Not available

GAAC - Generator Average Basic AC Quantities

PGN 65030

Priority	Ext Data Page	Data Page	PDU Format	PDU Specific	Default Source Address	Default Message ID	Transmit Rate
0x6	0x0	0x0	0xFE	0x06	0x2C (44)	0x18FE062C	100 ms
0x18			0x0FE06 (65030)				

SPN	Instrument	Byte / Bit	Range	Scaling	Offset
2440	Generator Avg. L-L AC Voltage	Byte 1 to 2	0 to 64255 V	1 A	0
2444	Generator Avg. L-N AC Voltage	Byte 3 to 4	0 to 64255 V	1 A	0
2436	Generator Avg. AC Frequency	Byte 5 to 6	0 to 501.9921875 Hz	7.8125*10 ⁻³ Hz	0
2448	Generator Avg. AC RMS Current	Byte 7 to 8	0 to 64255 A	1 A	0

GPAAC - Generator Phase A Basic AC Quantities

PGN 65027

Priority	Ext Data Page	Data Page	PDU Format	PDU Specific	Default Source Address	Default Message ID	Transmit Rate
0x6	0x0	0x0	0xFE	0x03	0x2C (44)	0x18FE032C	100 ms
0x18			0x0FE03 (65027)				

SPN	Instrument	Byte / Bit	Range	Scaling	Offset
2441	Generator Phase A Line Line AC RMS Voltage	Byte 1 to 2	0 to 64255 V	1 V	0
2445	Generator Phase A Line Neutral AC RMS Voltage	Byte 3 to 4	0 to 64255 V	1 V	0
2437	Generator Phase A AC Frequency	Byte 5 to 6	0 to 501.9921875 Hz	7.8125*10 ⁻³ Hz	0
2449	Generator Phase A AC RMS Current	Byte 7 to 8	0 to 64255 A	1 A	0

GPAACP - Generator Phase A AC Power

PGN 65026

NOTE: When the DSEG4500 is configured for an AMF application and the mains is on load, the values in SPN 2453 and 2461 change from generator to mains instrumentation

Priority	Ext Data Page	Data Page	PDU Format	PDU Specific	Default Source Address	Default Message ID	Transmit Rate
0x6	0x0	0x0	0xFE	0x02	0x2C (44)	0x18FE022C	100 ms
0x18			0x0FE02 (65026)				

SPN	Instrument	Byte / Bit	Range	Scaling	Offset
2453	Generator Phase A Real Power	Byte 1 to 4	-2000000000 to 2211081215 W	1 W	-2*10 ⁹
2461	Generator Phase A Apparent Power	Byte 5 to 8	-2000000000 to 2211081215 VA	1 VA	-2*10 ⁹

GPAACR - Generator Phase A AC Reactive Power

PGN 65025

NOTE: When the DSEG4500 is configured for an AMF application and the mains is on load, the values in SPN 2457, 2465 and 2519 change from generator to mains instrumentation.

Priority	Ext Data Page	Data Page	PDU Format	PDU Specific	Default Source Address	Default Message ID	Transmit Rate
0x6	0x0	0x0	0xFE	0x01	0x2C (44)	0x18FE012C	100 ms
0x18			0x0FE01 (65025)				

SPN	Instrument	Byte / Bit	Scaling	Scaling	Offset
2457	Generator Phase A Reactive Power	Byte 1 to 4	-2000000000 to 2211081215 var	1 var	-2*10 ⁹
2465	Generator Phase A Power Factor	Byte 5 to 6	-1.00000 to 2.921814	6.103515625*10 ⁻⁵	-1
2519	Generator Phase A Power Factor Lagging	Byte 7 Bits 1 to 2	00: Leading 01: Lagging / Unity 10: Error 11: Not Available		

GPBAC - Generator Phase B Basic AC Quantities

PGN 65024

Priority	Ext Data Page	Data Page	PDU Format	PDU Specific	Default Source Address	Default Message ID	Transmit Rate
0x6	0x0	0x0	0xFE	0x00	0x2C (44)	0x18FE002C	100 ms
0x18							
		0x0FE00 (65024)					

SPN	Instrument	Byte / Bit	Range	Scaling	Offset
2442	Generator Phase B Line Line AC RMS Voltage	Byte 1 to 2	0 to 64255 V	1 V	0
2446	Generator Phase B Line Neutral AC RMS Voltage	Byte 3 to 4	0 to 64255 V	1 V	0
2438	Generator Phase B AC Frequency	Byte 5 to 6	0 to 501.9921875 Hz	$7.8125 \cdot 10^{-3}$ Hz	0
2450	Generator Phase B AC RMS Current	Byte 7 to 8	0 to 64255 A	1 A	0

GPBACP - Generator Phase B AC Power

PGN 65023

 **NOTE:** When the DSEG4500 is configured for an AMF application and the mains is on load, the values in SPN 2454 and 2462 change from generator to mains instrumentation.

Priority	Ext Data Page	Data Page	PDU Format	PDU Specific	Default Source Address	Default Message ID	Transmit Rate
0x6	0x0	0x0	0xFD	0xFF	0x2C (44)	0x18FEFF2C	100 ms
0x18							
		0x0FDFF (65023)					

SPN	Instrument	Byte / Bit	Range	Scaling	Offset
2454	Generator Phase B Real Power	Byte 1 to 4	-2000000000 to 2211081215 W	1 W	$-2 \cdot 10^9$
2462	Generator Phase B Apparent Power	Byte 5 to 8	-2000000000 to 2211081215 VA	1 VA	$-2 \cdot 10^9$

GPBACR - Generator Phase B AC Reactive Power

PGN 65022

NOTE: When the DSEG4500 is configured for an AMF application and the mains is on load, the values in SPN 2458, 2466 and 2520 change from generator to mains instrumentation.

Priority	Ext Data Page	Data Page	PDU Format	PDU Specific	Default Source Address	Default Message ID	Transmit Rate
0x6	0x0	0x0	0xFD	0xFE	0x2C (44)	0x18FEFE2C	100 ms
0x18							
		0x0FD FE (65022)					

SPN	Instrument	Byte / Bit	Scaling	Scaling	Offset
2458	Generator Phase B Reactive Power	Byte 1 to 4	-2000000000 to 2211081215 var	1 var	-2*10 ⁹
2466	Generator Phase B Power Factor	Byte 5 to 6	-1.00000 to 2.921814 PF	6.103515625*10 ⁻⁵ PF	-1
2520	Generator Phase B Power Factor Lagging	Byte 7 Bits 1 to 2	00: Leading 01: Lagging / Unity 10: Error 11: Not Available		

GPCAC - Generator Phase C Basic AC Quantities

PGN 65021

Priority	Ext Data Page	Data Page	PDU Format	PDU Specific	Default Source Address	Default Message ID	Transmit Rate
0x6	0x0	0x0	0xFD	0xFD	0x2C (44)	0x18FEFD2C	100 ms
0x18							
		0x0FD FD (65021)					

SPN	Instrument	Byte / Bit	Range	Scaling	Offset
2443	Generator Phase C Line Line AC RMS Voltage	Byte 1 to 2	0 to 64255 V	1 V	0
2447	Generator Phase C Line Neutral AC RMS Voltage	Byte 3 to 4	0 to 64255 V	1 V	0
2439	Generator Phase C AC Frequency	Byte 5 to 6	0 to 501.9921875 Hz	7.8125*10 ⁻³ Hz	0
2451	Generator Phase C AC RMS Current	Byte 7 to 8	0 to 64255 A	1 A	0

GPCACP - Generator Phase C AC Power

PGN 65020

NOTE: When the DSEG4500 is configured for an AMF application and the mains is on load, the values in SPN 2455 and 2463 change from generator to mains instrumentation.

Priority	Ext Data Page	Data Page	PDU Format	PDU Specific	Default Source Address	Default Message ID	Transmit Rate
0x6	0x0	0x0	0xFD	0xFC	0x2C (44)	0x18FDFC2C	100 ms
0x18							
		0x0FDFC (65020)					

SPN	Instrument	Byte / Bit	Range	Scaling	Offset
2455	Generator Phase C Real Power	Byte 1 to 4	-2000000000 to 2211081215 W	1 W	-2*10 ⁹
2463	Generator Phase C Apparent Power	Byte 5 to 8	-2000000000 to 2211081215 VA	1 VA	-2*10 ⁹

GPCACR - Generator Phase C AC Reactive Power

PGN 65019

NOTE: When the DSEG4500 is configured for an AMF application and the mains is on load, the values in SPN 2459, 2467 and 2521 change from generator to mains instrumentation.

Priority	Ext Data Page	Data Page	PDU Format	PDU Specific	Default Source Address	Default Message ID	Transmit Rate
0x6	0x0	0x0	0xFD	0xFB	0x2C (44)	0x18FDFB2C	100 ms
0x18							
		0x0FDFB (65019)					

SPN	Instrument	Byte / Bit	Scaling	Scaling	Offset
2459	Generator Phase C Reactive Power	Byte 1 to 4	-2000000000 to 2211081215 var	1 var	-2*10 ⁹
2467	Generator Phase C Power Factor	Byte 5 to 6	-1.00000 to 2.921814 PF	6.103515625*10 ⁻⁵ PF	-1
2521	Generator Phase C Power Factor Lagging	Byte 7 Bits 1 to 2	00: Leading 01: Lagging / Unity 10: Error 11: Not Available		

GTACE - Generator Total kW Hours Export

PGN 65018

Priority	Ext Data Page	Data Page	PDU Format	PDU Specific	Default Source Address	Default Message ID	Transmit Rate
0x6	0x0	0x0	0xFD	0xFA	0x2C (44)	0x18FDFA2C	100 ms
0x18							
		0x0FDFA (65018)					

SPN	Instrument	Byte / Bit	Range	Scaling	Offset
2468	Generator Total kW Hours Export	Byte 1 to 4	0 to 4211081215 kWh	1 kWh	0

GTACER - Generator Total AC Reactive Energy

PGN 64910

Priority	Ext Data Page	Data Page	PDU Format	PDU Specific	Default Source Address	Default Message ID	Transmit Rate
0x6	0x0	0x0	0xFD	0x8E	0x2C (44)	0x18FD8E2C	250 ms
0x18							
		0x0FD8E (64910)					

SPN	Instrument	Byte / Bit	Range	Scaling	Offset
3593	Generator Total kvar Hours Export	Byte 1 to 4	0 to 4211081215 kvarh	1 kvarh	0

GTACP - Generator Total AC Power

PGN 65029

NOTE: When the DSEG4500 is configured for an AMF application and the mains is on load, the values in SPN 2452 and 2460 change from generator to mains instrumentation.

Priority	Ext Data Page	Data Page	PDU Format	PDU Specific	Default Source Address	Default Message ID	Transmit Rate
0x6	0x0	0x0	0xFE	0x05	0x2C (44)	0x18FE052C	100 ms
0x18							
		0x0FE05 (65029)					

SPN	Instrument	Byte / Bit	Range	Scaling	Offset
2452	Generator Total Real Power	Byte 1 to 4	-2000000000 to 2211081215 W	1 W	-2*10 ⁹
2460	Generator Total Apparent Power	Byte 5 to 8	-2000000000 to 2211081215 VA	1 VA	-2*10 ⁹

GTACPP - Generator Total AC Percent Power

PGN 64911

NOTE: When the DSEG45xx is configured for an AMF application and the mains is on load, the value in SPN 3590 changes from generator to mains instrumentation.

Priority	Ext Data Page	Data Page	PDU Format	PDU Specific	Default Source Address	Default Message ID	Transmit Rate
0x6	0x0	0x0	0xFD	0x8F	0x2C (44)	0x18FD8F2C	250 ms
0x18							
		0x0FD8F (64911)					

SPN	Instrument	Byte / Bit	Range	Scaling	Offset
3590	Generator Total Percent kW	Byte 1 to 2	-251 to 250.99 %	7.8125*10 ⁻³ %	-251

GTACR - Generator Total AC Reactive Power

PGN65028

NOTE: When the DSEG4500 is configured for an AMF application and the mains is on load, the values in SPN 2456, 2464 and 2518 change from generator to mains instrumentation.

Priority	Ext Data Page	Data Page	PDU Format	PDU Specific	Default Source Address	Default Message ID	Transmit Rate
0x6	0x0	0x0	0xFE	0x04	0x2C (44)	0x18FE042C	100 ms
0x18							
		0x0FE04 (65028)					

SPN	Instrument	Byte / Bit	Range	Scaling	Offset
2456	Generator Total Reactive Power	Byte 1 to 4	-2,000,000,000 to 2,211,081,215 var	1 var	-2*10 ⁹
2464	Generator Overall Power Factor	Byte 5 to 6	-1.00000 to 2.921814 PF	6.103515625*10 ⁻⁵ PF	-1
2518	Generator Overall Power Factor Lagging	Byte 7 to 8	00: Leading 01: Lagging / Unity 10: Error 11: Not Available		

9.1.1.3 MAINS

NOTE: The *Mains* instrumentation does not change depending on the engine file selected.

NOTE: The *Mains* instrumentation is only applicable when the G45xx is configured as AMF.

The *Utility* instrumentation listed in this section is what the DSE module transmits on the CANbus link when *J1939-75 Instrumentation* is enabled in the configuration.

ACS - AC Switching Device Status

PGN 64913

Priority	Ext Data Page	Data Page	PDU Format	PDU Specific	Default Source Address	Default Message ID	Transmit Rate
0x6	0x0	0x0	0xFD	0x91	0x2C (44)	0x18FD912C	250 ms
0x18							
		0x0FD91 (64913)					

SPN	Instrument	Byte / Bit	State
3546	Utility Circuit Breaker Status	Byte 1 Bits 4 to 6	000: Open 001: Closed 010: Locked Out 011-101: Available for SAE assignment 110: Error 111: Not available

UAAC - Utility Average Basic AC Quantities

PGN 65017

Priority	Ext Data Page	Data Page	PDU Format	PDU Specific	Default Source Address	Default Message ID	Transmit Rate
0x6	0x0	0x0	0xFD	0xF9	0x2C (44)	0x18FDF92C	100 ms
0x18							
		0x0FDF9 (65017)					

SPN	Instrument	Byte / Bit	Range	Scaling	Offset
2474	Utility Avg. L-L AC Voltage	Byte 1 to 2	0 to 64255 V	1 V	0
2478	Utility Avg. L-N AC Voltage	Byte 3 to 4	0 to 64255 V	1 V	0
2470	Utility Avg. AC Frequency	Byte 5 to 6	0 to 501.9921875 Hz	7.8125*10 ⁻³ Hz	0
2482	Utility Avg. AC RMS Current	Byte 7 to 8	0 to 64255 A	1 A	0

UPAAC - Utility Phase A Basic AC Quantities

PGN 65014

Priority	Ext Data Page	Data Page	PDU Format	PDU Specific	Default Source Address	Default Message ID	Transmit Rate
0x6	0x0	0x0	0xFD	0xF6	0x2C (44)	0x18FDF62C	100 ms
0x18							
		0x0FDF6 (65014)					

SPN	Instrument	Byte / Bit	Range	Scaling	Offset
2475	Utility Phase A Line Line AC RMS Voltage	Byte 1 to 2	0 to 64255 V	1 V	0
2479	Utility Phase A Line Neutral AC RMS Voltage	Byte 3 to 4	0 to 64255 V	1 V	0
2471	Utility Phase A AC Frequency	Byte 5 to 6	0 to 501.9921875 Hz	7.8125*10 ⁻³ Hz	0
2483	Utility Phase A AC RMS Current	Byte 7 to 8	0 to 64255 A	1 A	0

UPBAC - Utility Phase B Basic AC Quantities

PGN 65011

Priority	Ext Data Page	Data Page	PDU Format	PDU Specific	Default Source Address	Default Message ID	Transmit Rate
0x6	0x0	0x0	0xFD	0xF3	0x2C (44)	0x18FDF32C	100 ms
0x18							
		0x0FDF3 (65012)					

SPN	Instrument	Byte / Bit	Range	Scaling	Offset
2476	Utility Phase B Line Line AC RMS Voltage	Byte 1 to 2	0 to 64255 V	1 V	0
2480	Utility Phase B Line Neutral AC RMS Voltage	Byte 3 to 4	0 to 64255 V	1 V	0
2472	Utility Phase B AC Frequency	Byte 5 to 6	0 to 501.9921875 Hz	7.8125*10 ⁻³ Hz	0
2484	Utility Phase B AC RMS Current	Byte 7 to 8	0 to 64255 A	1 A	0

UPCAC - Utility Phase C Basic AC Quantities

PGN 65008

Priority	Ext Data Page	Data Page	PDU Format	PDU Specific	Default Source Address	Default Message ID	Transmit Rate
0x6	0x0	0x0	0xFD	0xF0	0x2C (44)	0x18FDF02C	100 ms
0x18							
		0x0FDF0 (65008)					

SPN	Instrument	Byte / Bit	Range	Scaling	Offset
2477	Utility Phase C Line Line AC RMS Voltage	Byte 1 to 2	0 to 64255 V	1 V	0
2481	Utility Phase C Line Neutral AC RMS Voltage	Byte 3 to 4	0 to 64255 V	1 V	0
2473	Utility Phase C AC Frequency	Byte 5 to 6	0 to 501.9921875 Hz	$7.8125 \cdot 10^{-3}$ Hz	0
2485	Utility Phase C AC RMS Current	Byte 7 to 8	0 to 64255 A	1 A	0

9.1.2 DM1 - CONDITIONS ACTIVE DIAGNOSTIC TROUBLE CODES

NOTE: All DM1s are transmitted from the DSE module using a default source address of 44 (0x2C), however this is configurable. Refer to the module's configuration for further clarification of the configured source address.

NOTE: If only one DM1 alarm is active the DM1 priority of the message is 6. If two or more DM1 alarms are active the priority of the message changes to 7.

NOTE: SPN 1216 Occurrence Count is not supported and is fixed to a value of 127 (i.e. not available).

NOTE: Once a fault condition is cleared, the corresponding DTCs continues to transmit via DM01 PGN for 10 seconds.

PGN 65226

The Amber Warning and Red Stop lamps are enabled for the DM01 message such that:

- SPN 623 Red Stop Lamp is 01 (Lamp On) if any of the supported alarms are active as a Shutdown or Electrical Trip alarm.
- SPN 624 Amber Warning Lamp is 01 (Lamp On) if any of the supported alarms are active as a Warning alarm.

Priority	Ext Data Page	Data Page	PDU Format	PDU Specific	Default Source Address	Default Message IDs	Transmit Rate
0x6/0x7	0x0	0x0	0xFE	0xCA	0x2C (44)	0x18FECA2C 0x1CFECA2C	1000 ms
0x18/0x1C		0x0FECA (65226)					

SPN	Instrument	Byte / Bit	Range	Scaling	Offset
624	Amber Warning Lamp	Byte 1 Bits 3 to 4	00: Lamp Off 01: Lamp On 10: Reserved 11: Not available		
623	Red Stop Lamp	Byte 1 Bits 5 to 6	00: Lamp Off 01: Lamp On 10: Reserved 11: Not available		
1214	Suspect Parameter Number	Byte 3 Bits 1 to 19	0 to 524,287	1	0
1215	Failure Mode Identifier	Byte 5 Bits 1 to 5	0 to 31	1	0
1706	SPN Conversion Method	Byte 6 Bit 8	0: Convert SPNs per the J1939-73 Version 4 definition 1: Convert SPNs per the J1939-73 Version 1, 2 or 3 definitions.		

Diagnostic Trouble Code FMI Conditions

Value	Condition
0	High Fault - Most Severe
1	Low Fault - Most Severe
2	Data Erratic, Intermittent or Incorrect
7	Mechanical System Not Responding
9	Abnormal Update Rate
11	Other Failure Mode
12	Failure
13	Out of Calibration
14	Special Instruction
15	High Fault - Least Severe
17	Low Fault - Least Severe
19	Data Error
31	Condition Exists

Diagnostic Trouble Codes Conditions

Named Alarm	SPN	FMI	
		Warning	Electrical Trip / Shutdown
Battery Over Voltage	168	15	0
Battery Under Voltage	168	17	1
Charge Alternator Failure	167	17	1
Coolant Temperature High	110	15	0
Coolant Temperature High Switch	110	15	0
DEF Level Low	1761	17	1
Digital Input A	520305	11	31
Digital Input B	520306	11	31
Digital Input C	520307	11	31
Digital Input D	520308	11	31
DPTC Filter	3701	11	31
ECU Amber	624	11	31
ECU Data Fail	639	9	19
ECU Red	623	11	31
Emergency Stop	3607	11	31
Engine Over Speed	190	15	0
Engine Under Speed	190	17	1
Failed to Start	1664	11	31
Failed to Stop	520193	11	31
Fan Speed Low	1639	17	1
Fuel Level High	96	15	0
Fuel Level Low	96	17	1
Fuel Tank Bund Level High	7785	15	0
Fuel Usage Running	183	11	31
Fuel Usage Stopped	183	11	31
Generator Over Frequency	2436	15	0
Generator Overcurrent	2448	15	0
Generator Over Voltage	2444	15	0
Generator Under Frequency	2436	17	1
Generator Under Voltage	2444	17	1
HEST Active	3698	15	0
kW Overload	2452	15	0
Low Coolant Level	2430	17	1
Low Coolant Level Switch	2430	17	1
Negative Phase Sequence Current	520202	15	0
Oil Pressure Low	100	17	1

Continued overleaf...

CAN Interface Specification (J1939-75)

Named Alarm	FMI		
	SPN	Warning	Electrical Trip / Shutdown
Oil Pressure Low Switch	100	17	1
Oil Pressure Sensor Fault	100	2	12
SCR Inducement	5246	11	31
Temperature Sensor Fault	110	2	12
Water In Fuel	97	11	31

10 FAULT FINDING

 **NOTE:** The below fault finding is provided as a guide checklist only. As the module can be configured to provide a wide range of different features, always refer to the source of the module configuration if in doubt.

10.1 STARTING

Symptom	Possible Remedy
Unit is inoperative	Check the battery and wiring to the unit. Check the DC supply. Check the DC fuse.
Read/Write configuration does not operate	
Unit shuts down	Check DC supply voltage is not above 35 Volts or below 9 Volts. Check the operating temperature is not above 70°C. Check the DC fuse.
Fail to Start is activated after pre-set number of attempts to start	Check wiring of fuel solenoid. Check fuel. Check battery supply. Check battery supply is present on the Fuel output of the module. Check the speed-sensing signal is present on the module's inputs. Refer to engine manual.
Continuous starting of generator when in the Auto Mode 	Check that there is no signal present on the "Remote Start" input. Check configured polarity is correct.
Generator fails to start on receipt of Remote Start signal.	Check Start Delay timer has timed out. Check signal is on "Remote Start" input. Confirm correct configuration of input is configured to be used as "Remote Start". Check that the oil pressure switch or sensor is indicating low oil pressure to the controller. Depending upon configuration, the set does not start if oil pressure is not low.
Pre-heat inoperative	Check wiring to engine heater plugs. Check battery supply. Check battery supply is present on the Pre-heat output of module. Check pre-heat configuration is correct.
Starter motor inoperative	Check wiring to starter solenoid. Check battery supply. Check battery supply is present on the Starter output of module. Ensure oil pressure switch or sensor is indicating the "low oil pressure" state to the controller.

10.2 LOADING

Symptom	Possible Remedy
Engine runs but generator does not take load	Check Warm up timer has timed out. Ensure generator load inhibit signal is not present on the module inputs. Check connections to the switching device. Note that the set does not take load in Manual/Start Mode  unless there is an active load signal.
Incorrect reading on engine gauges	Check engine is operating correctly.
Fail To Stop when engine is at rest	Check that sensor is compatible with the module and that the module configuration is suited to the sensor.

10.3 ALARMS

Symptom	Possible Remedy
Low Oil Pressure operates after engine has fired	Check engine oil pressure. Check oil pressure switch/sensor and wiring. Check configured polarity (if applicable) is correct (i.e. Normally Open or Normally Closed) or that sensor is compatible with the module and is correctly configured.
High Coolant Temperature operates after engine has fired.	Check engine temperature. Check switch/sensor and wiring. Check configured polarity (if applicable) is correct (i.e. Normally Open or Normally Closed) or that sensor is compatible with the module.
Shutdown fault operates	Check relevant switch and wiring of fault indicated on LCD display. Check configuration of input.
Electrical Trip fault operates	Check relevant switch and wiring of fault indicated on LCD display. Check configuration of input.
Warning fault operates	Check relevant switch and wiring of fault indicated on LCD display. Check configuration of input.
CAN ECU Amber CAN ECU Red CAN ECU Malfunction CAN ECU Protect	This indicates a fault condition detected by the engine ECU and transmitted to the DSE controller.
CAN Data Fail 	Indicates failure of the CAN data link to the engine ECU. Check all wiring and termination resistors (if required).
Incorrect reading on Engine gauges	Check engine is operating correctly. Check sensor and wiring paying attention to the wiring to terminal 10.
Fail To Stop when engine is at rest	Check that sensor is compatible with the module and that the module configuration is suited to the sensor.

10.4 COMMUNICATIONS

Symptom	Possible Remedy
CAN Data Fail 	Indicates failure of the CAN data link to the engine ECU. Check all wiring and termination resistors (if required).

10.5 INSTRUMENTS

Symptom	Possible Remedy
Inaccurate generator measurements on controller display	<p>Check that the CT primary, CT secondary and VT ratio settings are correct for the application.</p> <p>Check that the CTs are wired correctly with regards to the direction of current flow (p1, p2 and s1, s2) and additionally ensure that CTs are connected to the correct phase (errors occur if CT1 is connected to phase 2).</p> <p>Remember to consider the power factor ($kW = kVA \times \text{powerfactor}$).</p> <p>The controller is true RMS measuring so gives more accurate display when compared with an 'averaging' meter such as an analogue panel meter or some lower specified digital multimeters.</p> <p>The controller accuracy is better than 1% of full scale. Generator voltage full scale is 415 V ph-N, the accuracy is $\pm 4.15 \text{ V}$ (1 % of 415 V).</p>

10.6 MISCELLANEOUS

Symptom	Possible Remedy
Module appears to 'revert' to an earlier configuration	<p>When editing a configuration using the PC software it is vital that the configuration is first 'read' from the controller before editing it. This edited configuration must then be "written" back to the controller for the changes to take effect.</p> <p>When editing a configuration using the fascia editor, be sure to press the Auto Mode  (✓) button to save the change before moving to another item or exiting the fascia editor</p>

11 MAINTENANCE, SPARES, REPAIR AND SERVICING

The controller is *Fit and Forget*. As such, there are no user serviceable parts within the controller. In the case of malfunction, contact the original equipment manufacturer (OEM).

11.1 PURCHASING ADDITIONAL CONNECTOR PLUGS FROM DSE

If additional plugs are required, please contact our Sales department using the part numbers below.

11.1.1 PACK OF PLUGS

Module Type	Plug Pack Part Number
DSEG45xx	007-1156

11.1.2 INDIVIDUAL PLUGS

Module Terminal Designation	Plug Description	Part No.
1-9	9 way 5.08 mm	007-167
10-AUX	12 way 5.08 mm	007-109
21-24	4 way 10.16 mm	007-003
25-28	4 way 10.16 mm	007-003
29-32	4 way 5.08 mm	007-444
33-38	6 way 5.08 mm	007-446
	PC Configuration interface lead (USB type A – USB type B)	016-125

11.2 PURCHASING ADDITIONAL FIXING CLIPS FROM DSE

Item	Description	Part No.
	Module Fixing Clips (Packet Of 2)	020-406

12 WARRANTY

DSE Provides limited warranty to the equipment purchaser at the point of sale. For full details of any applicable warranty, refer to the original equipment supplier (OEM).

13 DISPOSAL

13.1 WEEE (WASTE ELECTRICAL AND ELECTRONIC EQUIPMENT)

Users of electrical and electronic equipment must store, collect, treat, recycle, and dispose of WEEE separately from other waste.



This page is intentionally left blank