



DEEP SEA ELECTRONICS

DSE7310 MKII & DSE7320 MKII

Configuration Suite PC Software Manual

Document Number: 057-243

Author: Fady Atallah

DEEP SEA ELECTRONICS LTD

Highfield House
Hunmanby
North Yorkshire
YO14 0PH
ENGLAND



Sales Tel: +44 (0) 1723 890099

E-mail : sales@deepseaelectronics.com
Website : www.deepseaelectronics.com

DSE7310 MKII & DSE7320 MKII Configuration Suite PC Software Manual

© Deep Sea Electronics LTD

All rights reserved. No part of this publication may be reproduced in any material form (including photocopying or storing in any medium by electronic means or other) without the written permission of the copyright holder except in accordance with the provisions of the Copyright, Designs and Patents Act 1988.

Applications for the copyright holder's written permission to reproduce any part of this publication must be addressed to Deep Sea Electronics LTD at the address above.

The DSE logo is a UK registered trademarks of Deep Sea Electronics LTD.

Any reference to trademarked product names used within this publication is owned by their respective companies.

Deep Sea Electronics LTD reserves the right to change the contents of this document without prior notice.

Amendments List

Issue	Comments
1	Initial release
2	Configurable Front Panel Editor access added DEF Level added for electronic engines
3	Update to Fuel Usage alarm. Added Fuel Use and Efficiency, Additional Alternative configurations, DSE2131, DSE2133, DSE2152 and Battery Charger expansion support.
4	Added missing options and correction of typos.
5	Updated for the DSE2500 MKII Remote Display.
6	Updated to version 4 of the module, adding Fuel Tank Bund High Level & Water in Fuel alarm inputs, Screensaver, Low Load, Configurable CAN Instrumentation, PLC Registers/Stores, Override Gencomm Instruments in the PLC, PLC Module Display, PLC in the Scada, and more...
7	Updated to version 5 of the module, adding Check Sync, communications with CAN AVRs, CAN Icon Instruments, additional DSE25xx MKII support from Expansion, ECU Specific and Escape Mode functions.
8	Updated to version 6 of the module introducing separate AC system support for mains & generator (applicable on DSE7320 MKII only), Accumulated Instrumentation Lock, Governor Gain & Frequency Adjust from the Scada, RS485 Stop Bits & Parity selection, and more...
9	Updated to version 7.0 of the module, added Power Up in Mode in Miscellaneous Options, MPU Fail Delay in start timers, and a major re-design of the configurable CAN instruments.
10	Terminology change from master/slave to client/server.

Typeface: The typeface used in this document is *Arial*. Care must be taken not to mistake the upper case letter I with the numeral 1. The numeral 1 has a top serif to avoid this confusion.

TABLE OF CONTENTS

Section	Page
1 INTRODUCTION	7
1.1 BIBLIOGRAPHY	7
1.1.1 INSTALLATION INSTRUCTIONS.....	7
1.1.2 MANUALS.....	7
1.1.3 OTHER.....	7
1.1.4 CLARIFICATION OF NOTATION.....	8
1.1.5 GLOSSARY OF TERMS.....	8
1.2 INSTALLATION AND USING THE DSE CONFIGURATION SUITE SOFTWARE	9
2 EDITING THE CONFIGURATION	10
2.1 SCREEN LAYOUT	10
2.2 MODULE	11
2.2.1 MODULE OPTIONS.....	11
2.2.2 MISCELLANEOUS OPTIONS.....	13
2.2.3 CONFIGURABLE FRONT PANEL EDITOR	16
2.2.4 DISPLAY CONFIGURATION	17
2.2.5 USER DEFINED STRINGS.....	20
2.2.6 EVENT LOG.....	21
2.2.7 DATA LOGGING.....	23
2.2.7.1 CONFIGURATION ITEMS 1 - 10.....	23
2.2.7.2 OPTIONS.....	25
2.3 APPLICATION	27
2.4 INPUTS	33
2.4.1 ANALOGUE INPUT CONFIGURATION.....	33
2.4.2 FLEXIBLE SENSOR F.....	34
2.4.3 EDITING THE SENSOR CURVE.....	36
2.4.4 DIGITAL INPUTS	37
2.4.4.1 DIGITAL INPUTS.....	37
2.4.5 ANALOGUE INPUTS	38
2.4.6 INPUT FUNCTIONS.....	39
2.5 OUTPUTS	43
2.5.1 DIGITAL OUTPUTS	43
2.5.2 VIRTUAL LEDS.....	44
2.5.3 OUTPUT SOURCES.....	45
2.6 TIMERS	54
2.6.1 START TIMERS.....	54
2.6.2 LOAD / STOPPING TIMERS	56
2.6.3 MODULE TIMERS	57
2.7 GENERATOR	58
2.7.1 GENERATOR OPTIONS	58
2.7.1.1 BREAKER CONTROL.....	59
2.7.1.2 GENERATOR PHASE ROTATION	59
2.7.1.3 GENERATOR KW RATING	60
2.7.2 GENERATOR VOLTAGE.....	61
2.7.2.1 UNDER VOLTAGE ALARMS.....	61
2.7.2.2 LOADING VOLTAGE	62
2.7.2.3 NOMINAL VOLTAGE	62
2.7.2.4 OVER VOLTAGE ALARMS.....	62
2.7.3 GENERATOR FREQUENCY	63
2.7.3.1 UNDER FREQUENCY ALARMS	64
2.7.3.2 LOADING FREQUENCY.....	64
2.7.3.3 NOMINAL FREQUENCY.....	64
2.7.3.4 OVER FREQUENCY ALARMS	64
2.7.3.5 RUN AWAY.....	65
2.7.3.6 OVER FREQUENCY OPTIONS.....	65
2.7.4 GENERATOR CURRENT	66
2.7.4.1 GENERATOR CURRENT OPTIONS.....	66
2.7.4.2 GENERATOR CURRENT ALARMS	67
2.7.4.3 OVERCURRENT ALARM	67
2.7.4.3.1 IMMEDIATE WARNING.....	67
2.7.4.3.2 IDMT ALARM.....	68
2.7.4.3.3 CREATING A SPREADSHEET FOR THE OVER CURRENT IDMT CURVE.....	69
2.7.4.4 SHORT CIRCUIT ALARM.....	71

2.7.4.4.1	CREATING A SPREADSHEET FOR THE SHORT CIRCUIT IDMT CURVE.....	72
2.7.4.5	NEGATIVE PHASE SEQUENCE.....	74
2.7.4.6	EARTH FAULT ALARM.....	74
2.7.4.7	DEFAULT CURRENT PROTECTION TRIPPING CHARACTERISTICS.....	76
2.7.5	GENERATOR POWER.....	78
2.7.5.1	OVERLOAD PROTECTION.....	78
2.7.5.2	LOAD CONTROL.....	79
2.7.5.3	REVERSE POWER.....	80
2.7.5.4	LOW LOAD.....	80
2.7.6	AVR.....	81
2.8	MAINS.....	82
2.8.1	MAINS OPTIONS.....	82
2.8.2	MAINS ALARMS.....	85
2.8.3	MAINS CURRENT.....	86
2.9	ENGINE.....	87
2.9.1	ENGINE OPTIONS.....	88
2.9.2	ECU (ECM).....	90
2.9.2.1	ECU (ECM) OPTIONS.....	90
2.9.2.2	ECU (ECM) ALARMS.....	94
2.9.2.2.1	ECU (ECM) DATA FAIL.....	94
2.9.2.2.2	DM1 SIGNALS.....	95
2.9.2.2.3	INLET TEMPERATURE.....	99
2.9.2.2.4	ADVANCED.....	100
2.9.3	OIL PRESSURE.....	103
2.9.4	COOLANT TEMPERATURE.....	104
2.9.4.1	COOLANT TEMPERATURE ALARM.....	104
2.9.4.2	COOLANT TEMPERATURE CONTROL.....	106
2.9.5	FUEL OPTIONS.....	107
2.9.5.1	FUEL CONTROL AND MONITORING.....	108
2.9.5.2	FUEL LEVEL ALARMS.....	111
2.9.5.3	ADVANCED ALARMS.....	113
2.9.5.4	FUEL USE AND EFFICIENCY.....	115
2.9.6	DEF LEVEL.....	117
2.9.8	GAS ENGINE OPTIONS.....	118
2.9.9	CRANKING.....	119
2.9.10	SPEED SENSING.....	121
2.9.11	SPEED SETTINGS.....	122
2.9.12	PLANT BATTERY.....	124
2.9.13	ENGINE ICON DISPLAYS.....	125
2.9.13.1	TITLE INSTRUMENTATION.....	125
2.9.13.2	ICON INSTRUMENTATION.....	126
2.10	COMMUNICATIONS.....	129
2.10.1	COMMUNICATION OPTIONS.....	129
2.10.2	RS232 PORT.....	130
2.10.2.1	BASIC.....	131
2.10.2.2	ADVANCED.....	133
2.10.2.3	SMS CONTROL.....	135
2.10.2.4	TROUBLESHOOTING MODEM COMMUNICATIONS.....	136
2.10.2.4.1	MODEM COMMUNICATION SPEED SETTING.....	136
2.10.2.4.2	GSM MODEM CONNECTION.....	136
2.10.3	RS485 PORT.....	137
2.10.4	REMOTE DISPLAY.....	139
2.11	SCHEDULER.....	140
2.11.1	SCHEDULER OPTIONS.....	140
2.11.2	BANK 1 / BANK 2.....	141
2.12	MAINTENANCE ALARM.....	142
2.13	CONFIGURABLE CAN INSTRUMENTATION.....	143
2.13.1	RECEIVED INSTRUMENTATION (1-30).....	143
2.13.1.1	INSTRUMENT CONFIGURATION.....	144
2.13.2	TRANSMITTED INSTRUMENTATION.....	147
2.13.2.1.1	INSTRUMENT CONFIGURATION.....	148
2.14	ALTERNATIVE CONFIGURATIONS.....	150
2.14.1	ALTERNATIVE CONFIGURATION OPTIONS.....	150
2.14.2	ALTERNATIVE CONFIGURATION 1 TO 5.....	151
2.14.2.1	CONFIGURATION OPTIONS.....	151
2.14.2.2	GENERATOR / MAINS / ENGINE.....	151
2.15	EXPANSION.....	152

2.15.1	2130 INPUT MODULES.....	153
2.15.1.1	ANALOGUE INPUT CONFIGURATION.....	154
2.15.1.2	ANALOGUE INPUTS.....	154
2.15.1.3	DIGITAL INPUTS.....	157
2.15.1.3.1	DIGITAL INPUTS.....	158
2.15.1.3.2	ANALOGUE INPUTS.....	159
2.15.2	DSE2131 INPUT MODULES.....	160
2.15.2.1	ANALOGUE INPUT CONFIGURATION.....	161
2.15.2.2	ANALOGUE INPUTS.....	162
2.15.2.3	DIGITAL INPUTS.....	165
2.15.3	DSE2133 INPUT MODULES.....	167
2.15.3.1	ANALOGUE INPUTS.....	168
2.15.4	DSE2152 OUTPUT MODULES.....	171
2.15.4.1	ANALOGUE OUTPUTS.....	172
2.15.4.2	CREATING / EDITING THE OUTPUT CURVE.....	173
2.15.5	DSE2157 RELAY MODULES.....	175
2.15.6	2510/2520 DISPLAY MODULE.....	176
2.15.7	2510/2520 MKII DISPLAY MODULES.....	177
2.15.8	2548 ANNUNCIATOR MODULES.....	178
2.15.9	BATTERY CHARGERS.....	180
2.16	ADVANCED.....	181
2.16.1	ADVANCED OPTIONS.....	181
2.16.1.1	PROTECTIONS.....	181
2.16.1.2	ESCAPE MODE.....	182
2.16.1.3	SYNCHRONISING TIMERS.....	182
2.16.1.4	AVR OPTIONS.....	183
2.16.1.5	AVR DATA FAIL.....	184
2.16.1.6	AVR FAULT.....	184
2.16.2	PLC.....	185
2.16.2.1	PLC LOGIC.....	185
2.16.2.2	PLC FUNCTIONS.....	ERROR! BOOKMARK NOT DEFINED.
2.16.2.3	MODULE DISPLAY.....	ERROR! BOOKMARK NOT DEFINED.
2.16.3	CONFIGURABLE GENCOMM PAGES.....	187
3	SCADA.....	189
3.1	GENERATOR IDENTITY.....	190
3.2	MIMIC.....	190
3.3	LANGUAGES.....	191
3.4	DIGITAL INPUTS.....	191
3.5	DIGITAL OUTPUTS.....	192
3.6	VIRTUAL LEDS.....	193
3.7	MAINS.....	194
3.7.1	FREQUENCY, VOLTAGES AND CURRENT.....	194
3.7.2	POWER.....	195
3.8	GENERATOR.....	196
3.8.1	FREQUENCY, VOLTAGES AND CURRENT.....	196
3.8.2	POWER.....	197
3.8.3	MULTISET.....	198
3.9	ENGINE.....	199
3.10	FUEL USE AND EFFICIENCY.....	200
3.11	FLEXIBLE SENSORS.....	201
3.12	CONFIGURABLE CAN INSTRUMENTATION.....	202
3.13	ALARMS.....	203
3.14	ENGINE ALARMS.....	204
3.14.1	CURRENT ENGINE ALARMS.....	204
3.14.2	PREVIOUS ENGINE ALARMS.....	204
3.15	STATUS.....	205
3.16	EVENT LOG.....	206
3.17	ENHANCED CANBUS.....	207
3.18	REMOTE CONTROL.....	208
3.19	MAINTENANCE.....	209
3.19.1	RECALIBRATE TRANSDUCERS.....	209
3.19.1.1	FLEXIBLE SENSORS.....	210
3.19.1.2	GENERATOR CT.....	211
3.19.1.3	MAINS CT.....	212
3.19.2	EXPANSION CALIBRATION.....	213
3.19.3	HOURS RUN AND NUMBER OF STARTS.....	213
3.19.4	TIME.....	214

3.19.5	ACCUMULATED INSTRUMENTATION.....	215
3.19.5.1	GENERATOR.....	215
3.19.5.2	MAINS.....	216
3.19.6	FUEL USE AND EFFICIENCY.....	217
3.19.7	MAINTENANCE ALARM RESET.....	218
3.19.8	ELECTRONIC ENGINE CONTROLS.....	219
3.19.9	MANUAL SPEED TRIM.....	220
3.19.10	MODULE LOCK.....	221
3.20	DATA LOG.....	223
3.20.1	DATA LOG STATUS.....	223
3.21	PLC.....	224
3.21.1	PLC LOGIC.....	224
3.21.2	PLC STORES.....	224
3.22	AVR.....	225
3.22.1	FREQUENCY, VOLTAGES AND CURRENT.....	225
3.22.2	DIAGNOSTICS.....	225
3.22.3	STATUS.....	226
3.22.4	CONTROL.....	226
3.22.5	AVR ALARMS.....	226
3.23	EXPANSION.....	227
4	ALARM TYPES.....	228
5	ALARM ARMING.....	229
5.1	ALWAYS.....	230
5.2	FROM STARTING.....	230
5.3	FROM SAFETY ON.....	230
5.4	ENGINE PROTECTION.....	230
5.5	OVERSHOOT.....	230
5.6	LOADING ALARMS.....	230

1 INTRODUCTION

The **DSE Configuration Suite PC Software** allows the DSE73xx MKII modules to be connected to a PC via USB A –USB B cable. Once connected the various operating parameters within the module are viewed or edited as required by the engineer. This software allows easy controlled access to these values.

This manual details the configuration of the DSE7310 MKII & DSE7320 MKII series controllers.

A separate document covers the older DSE7310 and DSE7320 modules configuration.

The DSE Configuration Suite PC Software must only be used by competent, qualified personnel, as changes to the operation of the module may have safety implications on the panel / generating set to which it is fitted. Access to critical operational sequences and settings for use by qualified engineers, may be barred by a security code set by the generator provider.

The information contained in this manual must be read in conjunction with the information contained in the appropriate module documentation. This manual only details which settings are available and how they may be used. A separate manual deals with the operation of the individual module (See section entitled *Bibliography* elsewhere in this document).

1.1 BIBLIOGRAPHY

This document refers to and is referred to by the following DSE publications which is obtained from the DSE website www.deepseaelectronics.com

1.1.1 INSTALLATION INSTRUCTIONS

DSE PART	DESCRIPTION
053-181	DSE7310 MKII & DSE7320 MKII installation instructions sheet

1.1.2 MANUALS

DSE PART	DESCRIPTION
057-151	DSE Configuration Suite PC Software Installation & Operation Manual
057-004	Electronic Engines and DSE wiring
057-253	DSE7310 MKII & DSE7320 MKII Operator Manual
057-278	DSE2510 MKII & DSE2520 MKII Operator Manual
057-279	DSE2510 MKII & DSE2520 MKII Software Manual
057-281	DSEA108 Operator Manual
057-283	DSEA108 Software Manual



1.1.3 OTHER

The following third party documents are also referred to:

ISBN	DESCRIPTION
1-55937-879-4	IEEE Std C37.2-1996 IEEE Standard Electrical Power System Device Function Numbers and Contact Designations. Published by Institute of Electrical and Electronics Engineers Inc

1.1.4 CLARIFICATION OF NOTATION

Clarification of notation used within this publication.

	NOTE:	Highlights an essential element of a procedure to ensure correctness.
	CAUTION!	Indicates a procedure or practice, which, if not strictly observed, could result in damage or destruction of equipment.
	WARNING!	Indicates a procedure or practice, which could result in injury to personnel or loss of life if not followed correctly.

1.1.5 GLOSSARY OF TERMS

Term	Description
DSE7xxx MKII	All modules in the DSE7xxx MKII range.
DSE7300 MKII, DSE73xx MKII	All modules in the DSE73xx MKII range.
DSE7310 MKII	DSE7310 MKII module/controller
DSE7320 MKII	DSE7320 MKII module/controller
DSE2510 MKII	DSE2510 MKII remote display module
DSE2520 MKII	DSE2520 MKII remote display module
DSE2500 MKII, DSE25xx MKII	DSE25xx MKII range remote display modules.
CAN	Controller Area Network Vehicle standard to allow digital devices to communicate to one another.
CDMA	Code Division Multiple Access. Cell phone access used in small number of world areas including parts of the USA and Australia.
CT	Current Transformer An electrical device that takes a large AC current and scales it down by a fixed ratio to a smaller scale.
BMS	Building Management System A digital/computer based control system for a building's infrastructure.
DEF	Diesel Exhaust Fluid (AdBlue) A liquid used as a consumable in the SCR process to lower nitric oxide and nitrogen dioxide concentration in engine exhaust emissions.
DM1	Diagnostic Message 1 A DTC that is currently active on the engine ECU (ECM).
DM2	Diagnostic Message 2 A DTC that was previously active on the engine ECU (ECM) and has been stored in the ECU's (ECM) internal memory.
DPF	Diesel Particulate Filter A filter fitted to the exhaust of an engine to remove diesel particulate matter or soot from the exhaust gas.
DPTC	Diesel Particulate Temperature Controlled Filter A filter fitted to the exhaust of an engine to remove diesel particulate matter or soot from the exhaust gas which is temperature controlled.
DTC	Diagnostic Trouble Code The name for the entire fault code sent by an engine ECU (ECM).
ECU/ECM	Engine Control Unit/Management An electronic device that monitors engine parameters and regulates the fuelling.
FMI	Failure Mode Indicator A part of DTC that indicates the type of failure, e.g. high, low, open circuit etc.
GSM	Global System for Mobile communications. Cell phone technology used in most of the World.

Continued over page...

Term	Description
HEST	High Exhaust System Temperature Initiates when DPF filter is full in conjunction with an extra fuel injector in the exhaust system to burn off accumulated diesel particulate matter or soot.
HMI	Human Machine Interface A device that provides a control and visualisation interface between a human and a process or machine.
IDMT	Inverse Definite Minimum Time
MSC	Multi-Set Communication
OC	Occurrence Count A part of DTC that indicates the number of times that failure has occurred.
PGN	Parameter Group Number A CAN address for a set of parameters that relate to the same topic and share the same transmission rate.
PLC	Programmable Logic Controller A programmable digital device used to create logic for a specific purpose.
SCADA	Supervisory Control And Data Acquisition A system that operates with coded signals over communication channels to provide control and monitoring of remote equipment
SCR	Selective Catalytic Reduction A process that uses DEF with the aid of a catalyst to convert nitric oxide and nitrogen dioxide into nitrogen and water to reduce engine exhaust emission.
SIM	Subscriber Identity Module. The small card supplied by the GSM/CDMA provider that is inserted into the cell phone, GSM modem or DSEGateway device to give GSM/GPRS connection.
SMS	Short Message Service The text messaging service of mobile/cell phones.
SPN	Suspect Parameter Number A part of DTC that indicates what the failure is, e.g. oil pressure, coolant temperature, turbo pressure etc.

1.2 INSTALLATION AND USING THE DSE CONFIGURATION SUITE SOFTWARE

For information in regards to instating and using the DSE Configuration Suite Software please refer to DSE publication: **057-151 DSE Configuration Suite PC Software Installation & Operation Manual** which is found on our website: www.deepseaelectronics.com

2 EDITING THE CONFIGURATION

This menu allows module configuration, to change the function of Inputs, Outputs and LED's, system timers and level settings to suit a particular application.

2.1 SCREEN LAYOUT

The screenshot shows a configuration menu titled "7320 MKII Configuration v6.0". At the top are "Previous" and "Next" buttons. Below the title is a list of configuration sections, with "7320 Configuration" highlighted in yellow. The sections include: Module, Application, Inputs, Outputs, Timers (with sub-items: Start Timers, Load/Stopping Timers, Module Timers), Generator, Mains, Engine, Communications, Scheduler, Maintenance Alarm, Configurable CAN Instrumentation, Alternative Configurations, Expansion, and Advanced. Callouts explain: "The type of configuration file being edited" (points to the title), "Move to the Previous or Next configuration page" (points to the navigation buttons), "Close this configuration file" (points to a close icon), "The coloured shading shows the currently selected page." (points to the yellow highlight), and "Click + or - to show or hide the sub sections within each sections." (points to the expand/collapse icons).

This screenshot shows the same configuration menu overlaid on an image of a "DEEP SEA ELECTRONICS" device. The menu items are now underlined and appear as links. Callouts explain: "Step forward or backward through previously viewed pages" (points to "Back" and "Forward" buttons), "Click to return to this page at any time" (points to a home icon), and "Click to select the subsection to view / edit" (points to a menu item).

2.2 MODULE

The module section is subdivided into smaller sections.

Select the required section with the mouse.

This section allows the user to change the options related to the module itself.

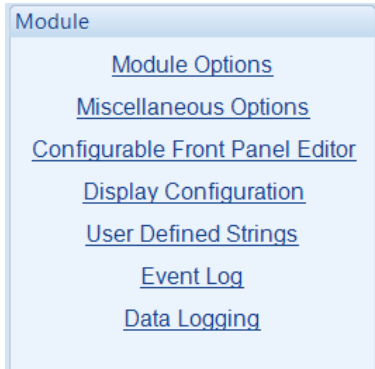

2.2.1 MODULE OPTIONS

Description

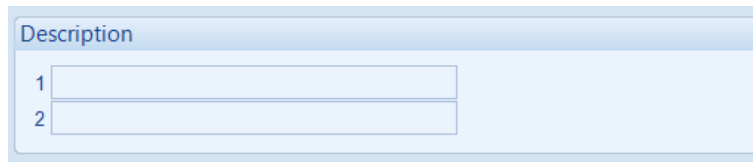

Parameter	Description
Description	Free entry boxes to allow the user to give the configuration file a description. Typically used to enter the job number, customer name, engineers name etc. This text is not shown on the module display and is only seen in the configuration file.

LED Indicators

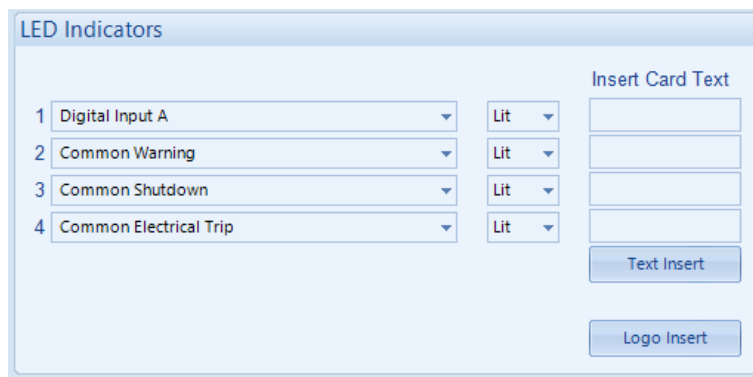

Parameter	Description
Function	Allows the user to select the function of the modules user configurable LED indicators. For details of possible selections, please see section entitled <i>Output sources</i> elsewhere in this document.
Insert Card Text	Enter a custom text to print on the text insert
Text Insert	Allows the user to print the text insert cards
Logo Insert	Allow the user to choose and print an image for the logo insert

Start Up Image

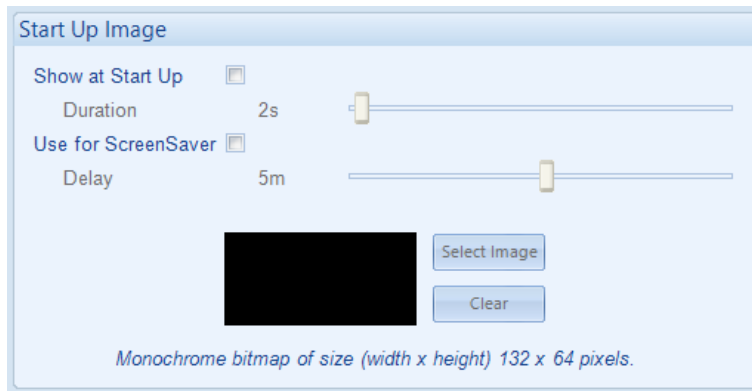

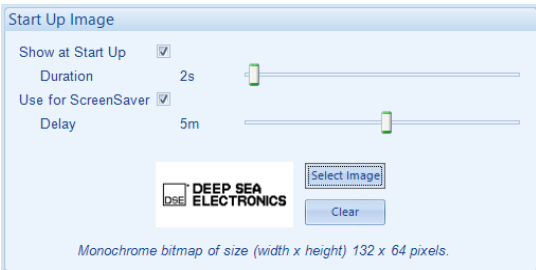
Parameter	Description
Show at Start Up	<p><input type="checkbox"/> = Start Up screen is disabled <input checked="" type="checkbox"/> = Enable a <i>Start Up Text</i> or <i>Image</i> to be displayed on the module's LCD at power up.</p> 
Use for Screensaver	<p><input type="checkbox"/> = Screensaver is disabled <input checked="" type="checkbox"/> = Module activates the Screensaver to show the selected image after inactivity in any mode for the configured <i>Delay</i> time. Press any button to 'end' the ScreenSaver.</p>
Select Image	Browse and select the image file to display at power up. The file required has to be a monochrome bitmap image of size 132 pixels in width by 64 pixels in height.
Clear	Clears the image file selection
Duration	Set the duration for which the <i>Start Up Image</i> is displayed at power up



2.2.2 MISCELLANEOUS OPTIONS

Miscellaneous Options

- Enable Fast Loading Feature
- Audible Alarm Prior to Starting
- All Warnings are Latched
- Enable Sleep Mode
- Enable Manual Fuel Pump Control
- Enable Manual Frequency Trim Control
- Support Right-To-Left Languages in Module Strings
- Power Up in Mode
- Enable Cool Down in Stop Mode
- Enable Maintenance Reset on Module Front Panel
- Enable Backlight Power Saving Mode
- Show Active DTC
- Show Inactive DTC
- Filter Generator Voltage Display
 - Filter Constant
- Filter Mains Voltage Display
 - Filter Constant

Parameter	Description
Enable Fast Loading	<p>NOTE: Enabling Fast Loading is only recommended where steps have been taken to ensure rapid start up of the engine is possible. (For example when fitted with engine heaters, electronic governors etc.)</p> <p><input type="checkbox"/> = Normal Operation, the safety on timer is observed in full. This feature is useful if the module is to be used with some small engines where pre-mature termination of the delay timer leads to overspeed alarms on start up.</p> <p><input checked="" type="checkbox"/> = The module terminates the safety on timer once all monitored parameters have reached their normal settings. This feature is useful if the module is to be used as a standby controller as it allows the generator to start and go on load in the shortest possible time.</p>
Audible Alarm Prior to Starting	<p><input type="checkbox"/> = The module starts the engine with no audible indication</p> <p><input checked="" type="checkbox"/> = The module gives an audible warning during the pre-start sequence as an indicator that the set is about to run. This is often a site's specification requirement of AUTO mode operation.</p>
All Warnings Are Latched	<p><input type="checkbox"/> = Normal Operation, the warnings and pre-alarms automatically reset once the triggering condition has cleared.</p> <p><input checked="" type="checkbox"/> = Warnings and pre-alarms latch when triggered. Resetting the alarm is performed by either an external reset applied to one of the inputs or, the 'Stop/Reset' pushbutton operated (once the triggering condition has been cleared).</p>

Parameters are continued overleaf...

Parameter	Description
Enable Sleep Mode	<p><input type="checkbox"/> = Normal operation <input checked="" type="checkbox"/> = Module goes into sleep (low current) mode after inactivity in STOP mode for the configured <i>Sleep Timer</i> time in <i>Module Timers</i> section. Press any button to 'wake' the module.</p> <p> NOTE: Sleep Mode is disabled when the module's USB, or any of its Modbus communication ports (RS232, RS485) are in use, or when it is Data Logging.</p> <p> NOTE: The Sleep Mode is disabled when the DSE25xx MKII remote display module is connected.</p>
Enable Manual Fuel Pump Control	<p><input type="checkbox"/> = Normal operation <input checked="" type="checkbox"/> = Allows manual fuel pump control when the "fuel level" instrument is being viewed.</p>
Enable Manual Frequency Trim Control	<p><input type="checkbox"/> = Normal operation <input checked="" type="checkbox"/> = When speed control over CAN is available, this allows manual speed trim control through the <i>Front Panel Running Editor</i>.</p>
Support Right-To-Left Languages in Module Strings	<p>Determines the direction of text input where supported (i.e. configurable input text)</p> <p><input type="checkbox"/> = Left to right language support <input checked="" type="checkbox"/> = Right to left language support</p>
Power Up in Mode	<p>Select the power up option: Stop: Allows the module to boot into <i>Stop Mode</i> Auto: Allows the module to boot into <i>Auto Mode</i> Manual: Allows the module to boot into <i>Manual Mode</i> Test: Allows the module to boot into <i>Test Mode</i></p>
Enable Cool Down in Stop Mode	<p><input type="checkbox"/> = Normal operation. Pressing the Stop button instantly opens the load switch and stops the generator. <input checked="" type="checkbox"/> = Alternative operation. Pressing the Stop button instantly opens the load switch and puts the generator into a cooling run. Pressing the Stop button again instantly stops the generator.</p>
Enable Maintenance Reset on Module Front Panel	<p><input type="checkbox"/> = The maintenance alarms are only reset through the SCADA section of the DSE Configuration Suite software or digital input if configured. <input checked="" type="checkbox"/> = The maintenance alarms are also reset by scrolling to the maintenance page on the module. By pressing and holding the <i>Stop / Reset</i> button on each alarm, the operator is able to reset each individual alarm.</p>
Enable Backlight Power Saving Mode	<p>Enables DC power saving by turning off the LCD Backlight when the module is not operated for the duration of the <i>Backlight Timer</i>.</p>
Show Active DTC ECU / ECM Only	<p>Enable this option to show the active ECU / ECM fault codes on the module display. (Active DTC are also called DM1 in J1939 ECU)</p>
Show Inactive DTC ECU / ECM Only	<p>Enable this option to show the in-active ECU (ECM) DTC on the module display. Inactive DTCs are the historical log of the ECU, where previous alarms have been cleared from the active DTC list. (Inactive DTC are called DM2 in J1939).</p>
Filter Generator Voltage Display	<p><input type="checkbox"/> = Normal operation. The display of generator voltage shows the instantaneous measurement. <input checked="" type="checkbox"/> = Filtered display. Generator voltage is averaged over time to produce a smoother display. This does not affect the response of voltage alarms.</p> <p> NOTE: The filtered voltage is only applicable on the module's display, and not applicable on the Scada or on any remote monitoring devices.</p>
Filter Constant	<p>Increase <i>Filter Constant</i> to further smooth the display of Generator Voltage.</p>

Parameters are continued overleaf...

Parameter	Description
Filter Mains Voltage Display	<p> <input type="checkbox"/> = Normal operation. The display of mains voltage shows the instantaneous measurement. <input checked="" type="checkbox"/> = Filtered display. Bus voltage is averaged over time to produce a smoother display. This does not affect the response of voltage alarms. </p> <hr/> <p>  NOTE: The filtered voltage is only applicable on the module's display, and not applicable on the Scada or on any remote monitoring devices. </p>
Filter Constant	Increase <i>Filter Constant</i> to further smooth the display of Mains Voltage.

2.2.3 CONFIGURABLE FRONT PANEL EDITOR

The Configurable Front Panel Editor allows generator OEMs to create a PIN protected, customised Front Panel Editor with up to two security access levels. Items may be added or removed as required by the generator supplier.

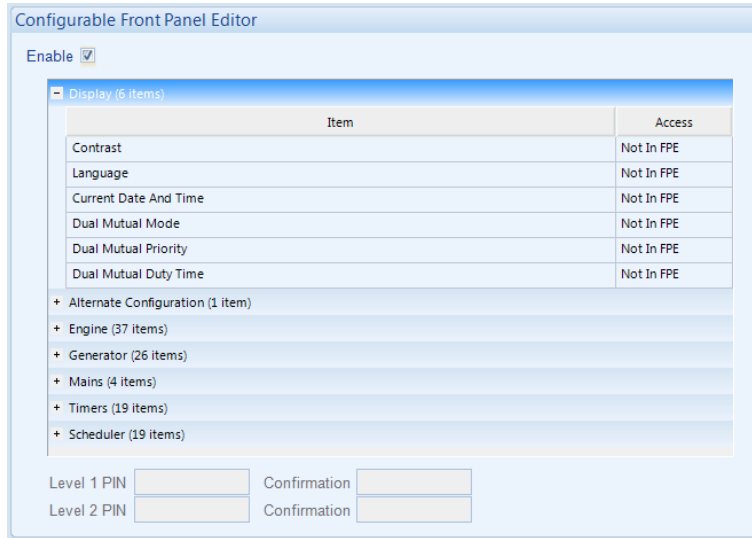



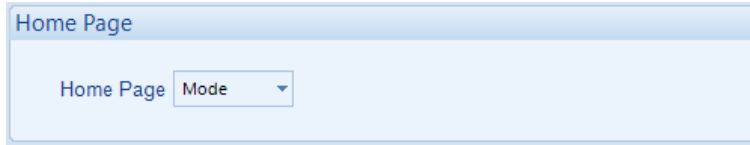

Items	Description
Enable	<input type="checkbox"/> = Configuration parameters are all accessible from Front Panel Editor. <input checked="" type="checkbox"/> = The Configuration parameters depend on their <i>Access</i> level.
Access	Permits the relevant item to be edited through the Front Panel Editor of the module. Not in FPE: The item cannot be edited through the Front Panel Editor No PIN: Allowing access to edit the item with no PIN Level 1 PIN: The Front Panel Editor asks for the configured <i>Level 1 PIN</i> to allow access to the relevant item. Level 2 PIN: The Front Panel Editor asks for the configured <i>Level 2 PIN</i> to allow access to the relevant item.
Level 1 PIN	Set four digit PIN number, then repeat the PIN in the <i>Confirmation</i> to configure <i>Level 1 PIN</i> for this access level.
Level 2 PIN	Set four digit PIN number, then repeat the PIN in the <i>Confirmation</i> to configure <i>Level 2 PIN</i> for this access level.

2.2.4 DISPLAY CONFIGURATION

Home Page



Parameter	Description
Home Page	<p style="text-align: center;">  </p> <p>Instrumentation: When no Navigation buttons are pressed for the duration of the <i>Page Timer</i>, the module's display scrolls through the <i>Configurable Status Screens</i>. Each of the <i>Configurable Status Screens</i> remains on the display for the duration of the <i>Scroll Timer</i>. The <i>Control Mode</i> page is not displayed automatically but is still accessible by manually</p> <p style="text-align: center;">  </p> <p>pressing the Navigation buttons.</p> <p style="text-align: center;">  </p> <p>Mode: When no Navigation buttons are pressed for the duration of the <i>Page Timer</i>, the module's display reverts back to show the <i>Control Mode Page</i>. The <i>Configurable Status Screens</i> are not displayed automatically but is still accessible by manually pressing</p> <p style="text-align: center;">  </p> <p>the Navigation buttons.</p>

Displayed Pages

Displayed Pages			
Page 1	Summary Screen	Page 6	Not Used
Page 2	Not Used	Page 7	Not Used
Page 3	Not Used	Page 8	Not Used
Page 4	Not Used	Page 9	Not Used
Page 5	Not Used	Page 10	Not Used

Parameter	Description
Page 1 to 10	Select the instrumentation parameter that is to be displayed for the specific <i>Configurable Status Screen</i> .

Example

In the example below, the *Home Page* is configured to *Instrumentation* so will scroll through the *Configurable Status Screens*. Depending on the application, the system designer selects the instrumentation parameters that are most important to constantly show on the module.

Home Page			
Home Page		Instrumentation	
Configurable Status Screens			
Page 1	Engine Coolant Temp	Page 6	Generator kW
Page 2	Engine Oil Pressure	Page 7	Generator Pf
Page 3	Engine Fuel Level	Page 8	Not Used
Page 4	Generator Frequency	Page 9	Not Used
Page 5	Generator Voltage L-N	Page 10	Not Used

Instrumentation Suppression

Instrumentation Suppression

Suppress the following instrumentation on the module screen

Generator Frequency <input type="checkbox"/>	Generator Voltage <input type="checkbox"/>
Mains Frequency <input type="checkbox"/>	Mains Voltage <input type="checkbox"/>
Current <input type="checkbox"/>	Power Factor <input type="checkbox"/>
kW <input type="checkbox"/>	kWh <input type="checkbox"/>
kVAr <input type="checkbox"/>	kVAh <input type="checkbox"/>
kVA <input type="checkbox"/>	



Suppress the following instrumentation on the module screen and SCADA

Charge Alternator

Suppress the following instrumentation on the module screen and SCADA, and disable PhPh alarms

Generator PhPh Voltage Mains PhPh Voltage

PhPh Voltage suppression is not supported for all the delta AC wiring topologies.

Parameter	Description
Generator Frequency	<input type="checkbox"/> = The <i>Generator Frequency Instrumentation</i> is displayed. <input checked="" type="checkbox"/> = The <i>Generator Frequency Instrumentation</i> is suppressed.
Generator Voltage	<input type="checkbox"/> = The <i>Generator Voltage Instrumentation</i> is displayed. <input checked="" type="checkbox"/> = The <i>Generator Voltage Instrumentation</i> is suppressed.
Mains Frequency 	<input type="checkbox"/> = The <i>Mains Frequency Instrumentation</i> is displayed. <input checked="" type="checkbox"/> = The <i>Mains Frequency Instrumentation</i> is suppressed.
Mains Voltage 	<input type="checkbox"/> = The <i>Mains Voltage Instrumentation</i> is displayed. <input checked="" type="checkbox"/> = The <i>Mains Voltage Instrumentation</i> is suppressed.
Current	<input type="checkbox"/> = The <i>Current Instrumentation</i> is displayed. <input checked="" type="checkbox"/> = The <i>Current Instrumentation</i> is suppressed.
Power Factor	<input type="checkbox"/> = The <i>Power Factor Instrumentation</i> is displayed. <input checked="" type="checkbox"/> = The <i>Power Factor Instrumentation</i> is suppressed.
kW	<input type="checkbox"/> = The <i>kW Instrumentation</i> is displayed. <input checked="" type="checkbox"/> = The <i>kW Instrumentation</i> is suppressed.
kWh	<input type="checkbox"/> = The <i>kWh Instrumentation</i> is displayed. <input checked="" type="checkbox"/> = The <i>kWh Instrumentation</i> is suppressed.
kvar	<input type="checkbox"/> = The <i>kvar Instrumentation</i> is displayed. <input checked="" type="checkbox"/> = The <i>kvar Instrumentation</i> is suppressed.
kvarh	<input type="checkbox"/> = The <i>kvarh Instrumentation</i> is displayed. <input checked="" type="checkbox"/> = The <i>kvarh Instrumentation</i> is suppressed.
kVA	<input type="checkbox"/> = The <i>kVA Instrumentation</i> is displayed. <input checked="" type="checkbox"/> = The <i>kVA Instrumentation</i> is suppressed.
kVAh	<input type="checkbox"/> = The <i>kVAh Instrumentation</i> is displayed. <input checked="" type="checkbox"/> = The <i>kVAh Instrumentation</i> is suppressed.
Charge Alternator	<input type="checkbox"/> = The <i>Charge Alternator Instrumentation</i> is displayed. <input checked="" type="checkbox"/> = The <i>Charge Alternator Instrumentation</i> is suppressed.
Generator PhPh Voltage	<input type="checkbox"/> = The <i>Generator Phase to Phase Voltage Instrumentation</i> is displayed and alarms are active. <input checked="" type="checkbox"/> = The <i>Generator Phase to Phase Voltage Instrumentation</i> is suppressed and alarms are disabled.
Mains PhPh Voltage 	<input type="checkbox"/> = The <i>Mains Phase to Phase Voltage Instrumentation</i> is displayed and fault detection are active. <input checked="" type="checkbox"/> = The <i>Mains Phase to Phase Voltage Instrumentation</i> is suppressed and fault detection are disabled.

2.2.5 USER DEFINED STRINGS

Page 1 and 2

Parameter	Description
Page Title	A free entry box to allow the user to give the custom display screen a title relating to the information contained on <i>Line 1 to 3</i> .
Line 1 to 3	Three free entry boxes, one for each line of the module's display. Typically used to show contact details or other information on the module's that is helpful to the end user of the generator.

About Page / Start Up Text

Parameter	Description
Text	A free entry box to allow the user to enter the text to be used for the <i>About Page</i> and <i>Start Up Text</i> .
Show at Start Up	<input type="checkbox"/> = The <i>Start Up Text</i> is disabled. <input checked="" type="checkbox"/> = The <i>Start Up Text</i> is enabled. The <i>Start Up Text</i> is displayed on the module's LCD for the configured <i>Duration</i> during power up.

2.2.6 EVENT LOG

Display Options

Display Options

Module display Date and time
 Engine hours run

Parameter	Description
Module Display	<p><input checked="" type="radio"/> Date and Time = The module displays what the <i>Date and Time</i> was when the <i>Event</i> was logged.</p> <p><input type="radio"/> Engine Hours Run = The module displays what the <i>Engine Hours</i> was when the <i>Event</i> was logged.</p>

Logging Options

Logging Options

Log the following events to the event log

Power up <input checked="" type="checkbox"/>	Fuel level when at rest <input type="checkbox"/>
ECU Lamps <input checked="" type="checkbox"/>	Fuel Level <input checked="" type="checkbox"/>
Mains return <input checked="" type="checkbox"/>	Engine starts <input checked="" type="checkbox"/>
Mains fail <input checked="" type="checkbox"/>	Engine stops <input checked="" type="checkbox"/>

'Repeat SMS' requires a GSM modem to be configured on the Communications/RS232 Port/Basic page

Shutdown alarms

Repeat SMS

Repeat delay 12h

Repeats 2

Electrical trip alarms

Repeat SMS

Repeat delay 12h

Repeats 2

Latched warnings

Unlatched warnings

Repeat SMS

Repeat delay 12h

Repeats 2

Maintenance alarms

Repeat SMS

Repeat delay 12h

Repeats 2

Parameter	Description
Power Up	<p><input type="checkbox"/> = Power up events are not logged in the module's event log</p> <p><input checked="" type="checkbox"/> = Power up events are logged when the DC Supply is applied to the module or whenever the module is rebooted</p>
ECU (ECM) Lamps	<p> NOTE: ECU Alarms are only available when the module is configured to communicate to an engine's ECU/ECM over CAN bus.</p> <p><input type="checkbox"/> = The ECU (ECM) alarm lamps signals are not logged.</p> <p><input checked="" type="checkbox"/> = The ECU (ECM) alarm lamps signals are logged when generated by the ECU (ECM)</p>
Mains Fail	<p><input type="checkbox"/> = <i>Mains Fail</i> events are not logged.</p> <p><input checked="" type="checkbox"/> = <i>Mains Fail</i> events are logged when the mains voltage/frequency rise above/falls below the configured trip levels for the duration of the <i>Mains Transient Delay</i> timer.</p>
Mains Return	<p><input type="checkbox"/> = <i>Mains Return</i> events are not logged.</p> <p><input checked="" type="checkbox"/> = <i>Mains Return</i> events are logged when the mains voltage/frequency falls below/rise above the configured return levels for the duration of the <i>Mains Transient Delay</i> timer.</p>

NOTE: Sending events by SMS is only available when the module is configured to communicate to a supported modem by RS232. Refer to section entitled *RS232 Port* elsewhere in this document for further details.

Parameter	Description
Fuel Level When at Rest	<input type="checkbox"/> = <i>Fuel Monitoring</i> events are not logged when the generator is at rest. Fuel level alarms are still logged if the appropriate alarm category is logged. <input checked="" type="checkbox"/> = <i>Fuel Monitoring</i> events are logged when the generator is at rest.
Fuel Level	<input type="checkbox"/> = <i>Fuel Monitoring</i> events are not logged when the generator running. Fuel level alarms are still logged if the appropriate alarm category is logged. <input checked="" type="checkbox"/> = <i>Fuel Monitoring</i> events are logged when the generator is running.
Engine Starts	<input type="checkbox"/> = <i>Engine Start</i> events are not logged. <input checked="" type="checkbox"/> = <i>Engine Start</i> events are logged when the generator successfully crank disconnects.
Engine Stops	<input type="checkbox"/> = <i>Engine Stop</i> events are not logged. <input checked="" type="checkbox"/> = <i>Engine Stop</i> events are when the <i>Stopping Timer</i> ceases.
Shutdown Alarms	<input type="checkbox"/> = <i>Shutdown Alarms</i> are not logged. <input checked="" type="checkbox"/> = <i>Shutdown Alarms</i> are logged when the moment they activate.
Shutdown Alarms Repeat SMS	<input type="checkbox"/> = <i>Shutdown Alarms</i> are only sent once via an SMS message. <input checked="" type="checkbox"/> = <i>Shutdown Alarms</i> are sent via SMS repeatedly until the <i>Repeats</i> value has been met. The delay between the repeated SMS is set by the <i>Repeats Delay</i> value.
Electrical Trip Alarms	<input type="checkbox"/> = <i>Electrical Trip Alarms</i> are not logged. <input checked="" type="checkbox"/> = <i>Electrical Trip Alarms</i> are logged when the moment they activate.
Electrical Trip Alarms Repeat SMS	<input type="checkbox"/> = <i>Electrical Trip Alarms</i> are only sent once via an SMS message. <input checked="" type="checkbox"/> = <i>Electrical Trip Alarms</i> are sent via SMS repeatedly until the <i>Repeats</i> value has been met. The delay between the repeated SMS is set by the <i>Repeats Delay</i> value.
Latched Warnings	<input type="checkbox"/> = <i>Latched Warnings Alarms</i> are not logged. <input checked="" type="checkbox"/> = <i>Latched Warnings Alarms</i> are logged when the moment they activate.
Unlatched Warnings	<input type="checkbox"/> = <i>Unlatched Warnings Alarms</i> are not logged. <input checked="" type="checkbox"/> = <i>Unlatched Warnings Alarms</i> are logged when the moment they activate.
Unlatched Warnings Alarms Repeat SMS	<input type="checkbox"/> = <i>Unlatched Warnings Alarms</i> are only sent once via an SMS message. <input checked="" type="checkbox"/> = <i>Unlatched Warnings Alarms</i> are sent via SMS repeatedly until the <i>Repeats</i> value has been met. The delay between the repeated SMS is set by the <i>Repeats Delay</i> value.
Maintenance Alarms	<input type="checkbox"/> = <i>Maintenance Alarms</i> are not logged. <input checked="" type="checkbox"/> = <i>Maintenance Alarms</i> are logged when the moment they activate.
Maintenance Alarms Repeat SMS	<input type="checkbox"/> = <i>Maintenance Alarms</i> are only sent once via an SMS message. <input checked="" type="checkbox"/> = <i>Maintenance Alarms</i> are sent via SMS repeatedly until the <i>Repeats</i> value has been met. The delay between the repeated SMS is set by the <i>Repeats Delay</i> value.

Engine DTC Logging

Logging Options (SMS messages will not be sent)

Engine DTC Logging ▾

Parameter	Description
Always	When selected, DTCs are immediately logged upon occurrence
Never	Select to disable Engine DTC logging
Shutdowns and Warnings	When selected, Engine DTCs are logged when an ECU Shutdown or ECU Warning occurs, the timestamp for the DTC in the event log is that of the Shutdown or Warning
Shutdowns Only	When selected, Engine DTCs are logged when an ECU Shutdown occurs, the timestamp for the DTC in the event log is that of the Shutdown

2.2.7 DATA LOGGING

The *Data Logging* section is subdivided into smaller sections. Select the required section with the mouse.

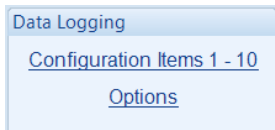

The module holds a rolling temporary store of up to ten parameters. This is saved to the *Data Log* as a *Logging Window* when any of the parameters exceed its configured *Trigger* or on an *External Trigger* (such as an alarm) activates. The configurable *Logging Window* allows the logged data to be recorded both *Pre-Trigger* and *Post-Trigger*.

The module has the ability to store up to 32 *Logging Windows*. If 10 parameters were configured to be logged, each with a *Log Interval* of 1 second, the length of each *Logging Window* would be 6 minutes and 47 seconds. As the module has the ability to store up to 32 *Logging Windows* on a rolling update, this results in a minimum total of 3 hours 37 minutes and 4 seconds of logged data. This time is extendable as the size of each *Logging Window* varies upon the number of selected parameters and their *Log Interval*.

The *Data Logging* is viewed using the *Data Log Viewer* application, which is accessed from the DSE Configuration Suite PC Software under the *Tools* menu.

2.2.7.1 CONFIGURATION ITEMS 1 - 10

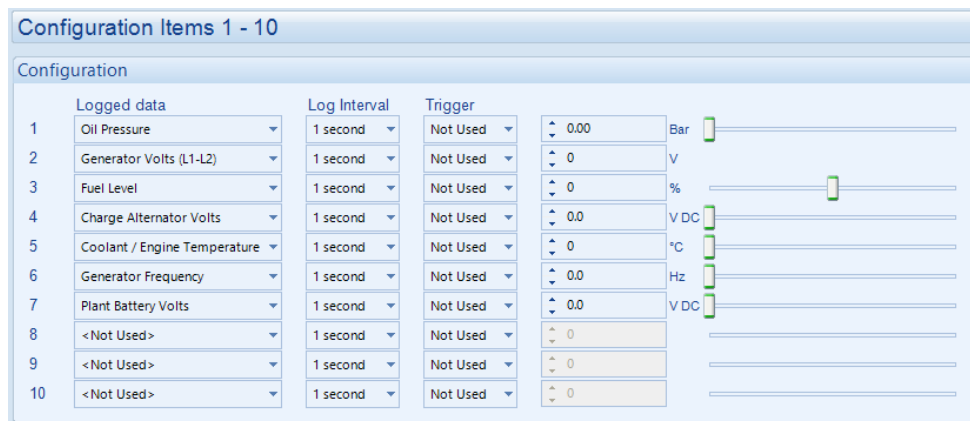

Parameter	Description
Logged Data	Select the instrument required to be logged: Specific Register Instrumentation Status
Log Interval	Select the logging interval of the data
Trigger	Select when the instrument is logged compared to the configurable value of the slider

Specific Register

NOTE: The Gencomm (MODBUS) address table for the module is available upon request by contacting DSE technical support: support@deepseaelectronics.com.

Specific Register enables the user to configure a Gencomm (MODBUS) address for the *Data Logger* to obtain information from.

The image below shows a typical example when reading battery voltage:

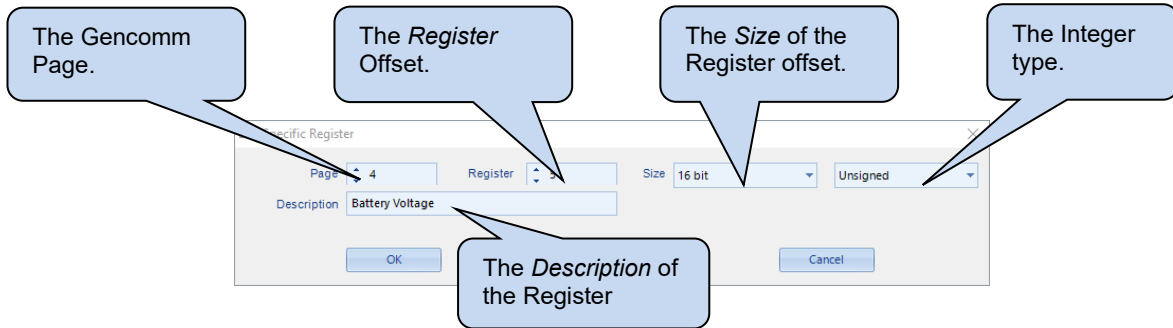

2.2.7.2 OPTIONS

Settings

Parameter	Description
Only Log When Engine is Running	<input type="checkbox"/> = The module logs data regardless of engine running state. <input checked="" type="checkbox"/> = The module only logs data when the engine is running.
Keep Oldest Data	<input type="checkbox"/> = When the logging memory is full, the module overwrites the oldest data first with the new data. <input checked="" type="checkbox"/> = When the logging memory is full, the module stops recording new data.

External Triggers

Parameter	Description
Trigger	Select an external trigger to initiate a data log
Polarity	Select the polarity of the trigger. Energise: the data log is triggered when the configured trigger goes active. De-Energise: the data log is triggered when the configured trigger goes inactive

Logging Window

Parameter	Description
Pre-Trigger	Shows the duration of time before the trigger, during which the data is logged.
Post-Trigger	Shows the duration of time after the trigger, during which the data is logged.
Logging Window	Shows the total duration of data logging time, combining the duration before and after the trigger.

Example 1

In the example below, the selected three parameters are logged when the *Generator Total Power* exceeds the set trip level of 150 kW.

The *Data Log* in the module contains the values of these three parameters for the duration of the *Logging Window*, that is 11 m 19 s before the *Generator Total Power* exceeded 150 kW and 11 m 20 s after that.

The screenshot shows the configuration interface for 10 items. Item 3 is configured with 'Generator Total Power' as the logged data, a 1-second interval, and a trigger of 'Is greater than' 150 kW. The logging window is shown as a horizontal timeline from 11m 19s to 11m 20s, with a total duration of 22m 39s.

Item	Logged data	Log Interval	Trigger	Value	Unit
1	Coolant / Engine Temperature	1 second	Not Used	0	°C
2	Oil Pressure	1 second	Not Used	0.00	Bar
3	Generator Total Power	1 second	Is greater than	150	kW
4	<Not Used>	1 second	Not Used	0	
5	<Not Used>	1 second	Not Used	0	
6	<Not Used>	1 second	Not Used	0	
7	<Not Used>	1 second	Not Used	0	
8	<Not Used>	1 second	Not Used	0	
9	<Not Used>	1 second	Not Used	0	
10	<Not Used>	1 second	Not Used	0	

Example 2

In the example below, the selected four parameters are logged when a *Common Alarm* occurs on the controller. The *Data Log* in the module contains the values of these four parameters for the duration of the *Logging Window*, that is 16 m 59 s before the *Alarm* occurred.

The screenshot shows the configuration interface for 10 items, identical to Example 1. Below it, the 'External Triggers' section shows 'Trigger 1' set to 'Common Alarm' with 'Energise' polarity. The logging window is shown as a horizontal timeline from 16m 59s to 0m 0s, with a total duration of 16m 59s.

Item	Logged data	Log Interval	Trigger	Value	Unit
1	Coolant / Engine Temperature	1 second	Not Used	0	°C
2	Oil Pressure	1 second	Not Used	0.00	Bar
3	Generator Total Power	1 second	Is greater than	150	kW
4	Generator Frequency	1 second	Not Used	0.0	Hz
5	<Not Used>	1 second	Not Used	0	
6	<Not Used>	1 second	Not Used	0	
7	<Not Used>	1 second	Not Used	0	
8	<Not Used>	1 second	Not Used	0	
9	<Not Used>	1 second	Not Used	0	
10	<Not Used>	1 second	Not Used	0	

2.3 APPLICATION

ECU (ECM) Options

 **NOTE:** For further details and instructions on ECU (ECM) options and connections, refer to DSE Publication: *057-004 Electronic Engines and DSE Controllers* which are found on our website: www.deepseaelectronics.com

ECU (ECM) Options

Engine Type Conventional Diesel ▾

Enhanced J1939

Alternative Engine Speed

Modbus Engine Comms Port RS485 Port ▾

Parameter	Description
Engine Type	<p>Select the appropriate engine type</p> <p>Conventional Engine: Select this for a traditional (non-electronic) engine, either Energise to Run or Energise to Stop.</p> <p>Conventional Gas Engine: Select this for a traditional (non-electronic) engine and require Gas engine functionality. This enables control of configurable outputs for <i>Gas Choke and Gas Ignition</i> and instructs the module to follow the gas engine timers.</p> <p>Other Engines: The list of supported CAN (or MODBUS) engines is constantly updated, check the DSE website at www.deepseaelectronics.com for the latest version of Configuration Suite software.</p>
Enhanced J1939	<p><input type="checkbox"/> = The module reads 'Basic' instrumentation from the engine ECU (ECM) and display (where supported by the engine) :</p> <ul style="list-style-type: none"> • Engine Speed • Oil Pressure • Engine Coolant Temperature • Hours Run <p><input checked="" type="checkbox"/> = The module reads and display an 'Enhanced' instrumentation list (where supported by the engine) :</p> <ul style="list-style-type: none"> • Engine Speed • Engine Speed Biasing (Subject to <i>ECM Speed Control</i> setting) • Oil Pressure • Engine Coolant Temperature • Hours Run • Engine Oil Temperature • Exhaust Temperature • Fuel Pressure • Total Fuel used • Fuel Consumption • Inlet Manifold Temperature • Coolant Pressure • Turbo Pressure <p>Where an instrument is not supported by the engine ECU (ECM), the instrument is not displayed.</p> <p>DSE Reserve the right to change these lists in keeping with our policy of continual development.</p>

Parameters are continued overleaf...

Editing the Configuration

Parameter	Description
Alternative Engine Speed	<input type="checkbox"/> = The engine is instructed to run at its <i>Nominal Speed</i> as configured by the Engine Manufacturer. <input checked="" type="checkbox"/> = The engine is instructed to run at its <i>Alternative Speed</i> as configured by the Engine Manufacturer.
MODBUS Engine Comms Port	RS485 Port : The modules RS485 port is used to communicate to the engine (when a MODBUS engine type is selected). DSENet Port : The modules DSENet port is used to communicate to the engine (when a MODBUS engine type is selected. This 'frees' the RS485 port in case connection to BMS or other RS485 compatible equipment is required.

Dual Mutual Standby

When a start request is available, the module in duty starts the generator set to supply power to the load. The start request is initiated by one of the following:

Activation of a digital input configured as *Remote Start on Load*
 Mains Failure (**DSE7320 MKII Only**)

If the engine fails to start, or is unavailable due to maintenance, engine shutdown etc, the next priority set starts and takes over to supply power to the load.

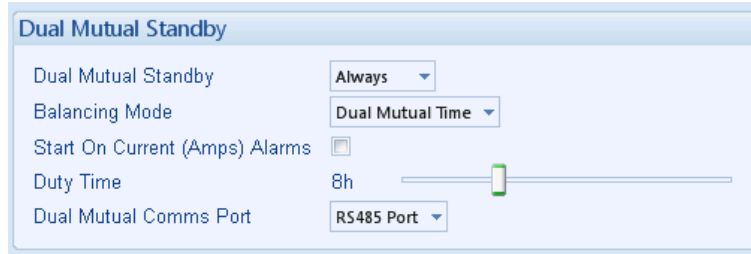

Parameter	Description
Dual Mutual Standby	Select when the feature is active Disabled: The module operates as a standalone controller Always: The <i>Dual Mutual Standby</i> is always active On Input: The <i>Dual Mutual Standby</i> is only active when a digital input configured for <i>Dual Mutual Standby</i> is active. This allows an external device or switch to enable/disable the feature.
Balancing Mode	Select how the modules are chosen for <i>Dual Mutual Standby</i> duty run Dual Mutual Time: Load balancing is based upon the configuration of the <i>Duty Time</i> , the modules duty runs change over at the configured <i>Duty Time</i> intervals. Engine Hours: The <i>Dual Mutual Standby</i> is based upon the difference in engine run hours, the modules change over when the difference in <i>Engine Hours</i> is higher than the configured <i>Duty Time</i> Set Priority: The <i>Dual Mutual Standby</i> is based upon the <i>MSC Priority</i> set in the <i>SCADA</i>
Start On Current (Amps) Alarms	This option allows the module to start and run the generator when the other module has a <i>Current (Amps) Alarm</i> . The alarms are: Generator Overcurrent IDMT Generator Earth Fault Generator Short Circuit <input type="checkbox"/> = The module does not start the generator when the other module has an active <i>Current (Amps) Alarm</i> . This prevents the generator from starting and closing onto the same potential fault, for example a short circuit. <input checked="" type="checkbox"/> = The module starts the generator when the other module has an active <i>Current (Amps) Alarm</i> .
Duty Time	Defines the hours difference the module maintains with the other controllers in <i>Dual Mutual Standby</i> . Based on the <i>Balancing Mode</i> selection, this defines <i>Duty Time</i> or the <i>Engine Hours</i> difference. The modules change over when the difference in hour meters is higher than the configured <i>Duty Time</i> or <i>Engine Hours</i> (whichever is selected).
Dual Mutual Comms Port	Select the communication port used for the <i>Dual Mutual Standby</i> : RS485 RS232

Auto Load Sensing



Auto Load Sensing

Enable Auto Load Sensing

Option	Description
Enable Auto Load Sensing	<input type="checkbox"/> = The module operates as normal. <input checked="" type="checkbox"/> = <i>Auto load sensing</i> is enabled. When called to run off load, if a load is detected, the module forces the load switch to close (if connected) and enables the cooldown timer when the set is requested to stop. This is to ensure the set is cooled down before stopping after running with an unexpected load(i.e. In a manual load switch system).

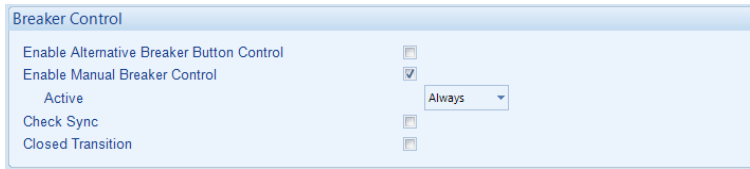
Breaker Control



Parameter	Description
Enable Alternative Breaker Control Button	Controls the operation of the fascia mounted load switch control buttons (manual mode only) <input type="checkbox"/> = Normal operation, pressing the respective load switch control button causes the supply to go on load, if it was available. Only a transfer is possible without the ability to open both breakers. <input checked="" type="checkbox"/> = Alternative operation. If a supply is on load and that supply's load switch button is pressed, the load switch opens. Pressing the button again closes the button. Pressing the 'other' button when a supply is on load causes a transfer to the 'other' supply (if available).
Enable Manual Breaker Control	<input type="checkbox"/> = Normal operation. When running in Manual mode, activation of any on load request causes the generator breaker to close. <input checked="" type="checkbox"/> = When running in Manual mode, only the following load requests cause the generator breaker to close: - Pressing the <i>Close Generator Button</i> on the module front fascia - Activating a digital input configured for <i>Close Generator</i> This also allows opening the generator breaker when running in Manual even if a load request is available.
Active	Always: <i>Manual Breaker Control</i> is always active. On Input: <i>Manual Breaker Control</i> is only active when a digital input configured for <i>Manual Breaker Mode</i> is active.
Check Sync 	<input type="checkbox"/> = None check sync operation <input checked="" type="checkbox"/> = During load transfer from Mains to Generator or Generator to Mains, the module only closes its breaker within the check sync window. See overleaf for description of the <i>Check Sync</i> options.
Closed Transition 	NOTE: It is not possible to write the configuration to the module if the <i>Closed Transition</i> option is enabled and the AC Systems in the Generator Options and in the Mains Options are not the same in either the <i>Main</i> or <i>Alternative Configurations</i> . <input type="checkbox"/> = Break before make operation. <input checked="" type="checkbox"/> = During load transfer, the module only closes its breaker within the check sync window. See overleaf for description of the <i>Check Sync</i> options.

Check Sync



= Only available on DSE7320 MKII AMF Modules

Before the breaker is closed, the following configurable conditions must be met.

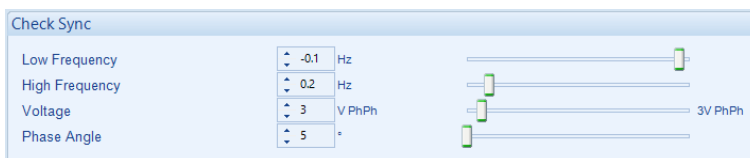

Parameter	Description
Low Frequency High Frequency	The difference between the two supplies frequencies must be between the <i>Check Sync Low Frequency</i> and <i>Check Sync High Frequency</i> .
Voltage	The difference between the two supplies voltages must be equal to or below the <i>Check Sync Voltage</i> .
Phase	The phase of the two supplies must be equal to or below the <i>Check Sync Phase Angle</i> .

Check Sync Assistant



= Only available on DSE7320 MKII AMF Modules

Parameter	Description
AVR	<p>NOTE: Check Sync Assistant with <i>AVR</i> is used when a CAN AVR is connected to the module's ECU port. This enables the module to control the Generator voltage through CAN messages before the <i>Closed Transition</i> period.</p> <p>NOTE: At the time of writing, only the DSEA109 AVR is supported. For further details, refer to DSE Publication: <i>057-295 DSEA109 Operator Manual</i> available on our website: www.deepseaelectronics.com</p> <p><input type="checkbox"/> = No CAN messages is sent from the ECU port to the CAN AVR. <input checked="" type="checkbox"/> = The module sends CAN messages to the CAN AVR to control the generator's output voltage, for the <i>Voltage Check Sync</i> takes place.</p>
Speed Trim	<p>NOTE: Check Sync Assistant with <i>Speed Trim</i> is only applicable with speed trim enabled Electronic CAN Engines, and when <i>ECU Data Fail</i> alarm is not active.</p> <p><input type="checkbox"/> = No speed CAN message is sent to the engine ECU. <input checked="" type="checkbox"/> = The module controls the Electronic CAN Engine to match the generator frequency with the mains frequency for the <i>Frequency</i> and <i>Phase Angle Check Sync</i> take place.</p>

Fail To Sync Alarm



= Only available on DSE7320 MKII AMF Modules

Used to detect that the check sync process is taking a long time. This occurs when the 'supplies' are not in sync (within the *Check Sync* window).

Parameter	Description
Action	<p>Determines the action to take upon a <i>Fail to Sync</i>.</p> <p>Electrical Trip: The set is stopped with an <i>Electrical Trip</i> alarm.</p> <p>Indication: The set continues to run and no alarm is raised. This is used for internal use, such as in the <i>PLC Logic</i> or <i>Virtual Leds</i>.</p> <p>Warning: The set continues to run without any transition to the Mains.</p>
Return To Open Transition	<p><input type="checkbox"/> = The load remains on the generator. <input checked="" type="checkbox"/> = This is only applicable with <i>Action</i> to <i>Indication</i>. The load is transferred to Mains.</p>
Delay	<p>The time to allow for successful sync check to take place. Should the process continue longer than <i>Delay</i>, the <i>Action</i> above is taken.</p>

2.4 INPUTS

The *Inputs* section is subdivided into smaller sections. Select the required section with the mouse.

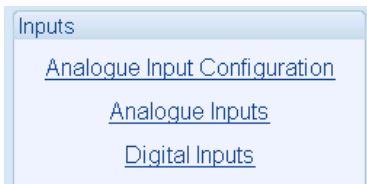

2.4.1 ANALOGUE INPUT CONFIGURATION

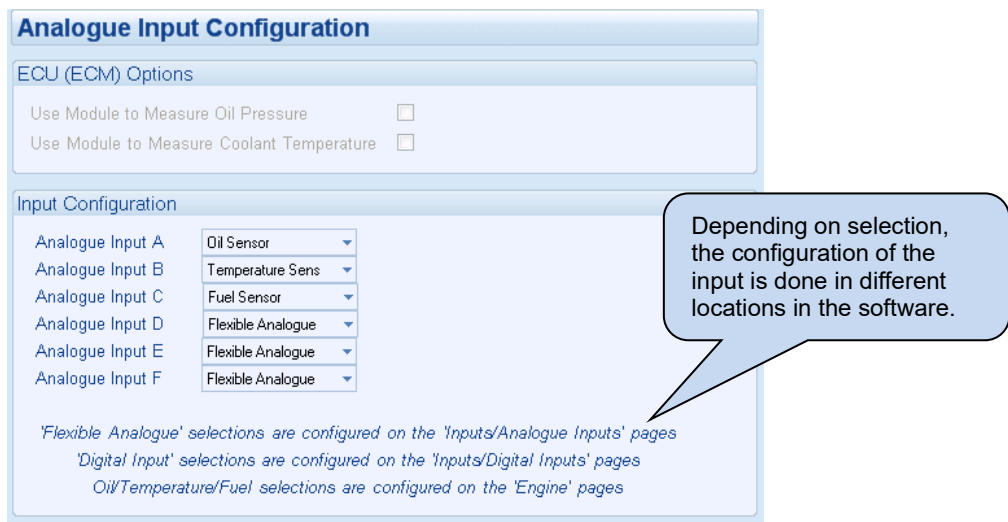

Parameter	Description
Module To Measure Oil Pressure	(Available only when the module is configured for connection to a CAN engine.) <input type="checkbox"/> = The measurements are taken from the ECU (ECM). <input checked="" type="checkbox"/> = The module ignores the CAN measurement and uses the analogue sensor input.
Module To Measure Coolant Temperature	(Available only when the module is configured for connection to a CAN engine.) <input type="checkbox"/> = The measurements are taken from the ECU. <input checked="" type="checkbox"/> = The module ignores the CAN measurement and uses the analogue sensor input.
Analogue Input A	Select what the analogue input is to be used for: Digital Input: Configured on the <i>Inputs/Digital Inputs</i> pages. Flexible Analogue: Configured on the <i>Inputs/Analogue Inputs</i> pages. Fuel Sensor: Configured on the <i>Engine</i> pages. Not Used: The input is disabled. Oil Sensor: Configured on the <i>Engine</i> pages. Temperature Sensor: Configured on the <i>Engine</i> pages.
Analogue Input B, C, D, E, and F	Select what the analogue input is to be used for: Digital Input: Configured on the <i>Inputs/Digital Inputs</i> pages. Flexible Analogue: Configured on the <i>Inputs/Analogue Inputs</i> pages. Fuel Sensor: Configured on the <i>Engine</i> pages. Not Used: The input is disabled. Temperature Sensor: Configured on the <i>Engine</i> pages.

2.4.2 FLEXIBLE SENSOR F

Analogue input D is configured for *Flexible Sensor*.

Parameter	Description
Sensor Name	Enter the <i>Sensor Name</i> , this text is shown on the module display when a sensor alarm activates.
Input Type	Select the sensor type and curve from a pre-defined list or create a user-defined curve. Current: for sensors with maximum range of 0 mA to 20 mA. Resistive: for sensors with maximum range of 0 Ω to 480 Ω. Voltage: for sensors with maximum range of 0 V to 10 V. Pressure: The input is configured as a pressure sensor. Percentage: The input is configured as a percentage sensor. Temperature: The input is configured as a temperature sensor.
Enable Volume Calculation	(Available on all Flexible Analogue Inputs when configured to Percentage). <input type="checkbox"/> = The Volume Calculation is disabled. The sensor reading is displayed alone. <input checked="" type="checkbox"/> = The Volume Calculation is enabled to display the tank's liquid volume on the controller.
Volume	Select the tank size and the unit for the display (Imperial Gallons, Litres, or US Gallons).

Parameter	Description
Enable Alarm	<input type="checkbox"/> = The Alarm is disabled. <input checked="" type="checkbox"/> = The module detects an open circuit when the sensor is disconnected.
Alarm String	Enter the text that is shown on the display when the alarm occurs.

Editing the Configuration

Sensor Alarms

Alarm Arming Always ▾

Low Alarm Enable

Action Shutdown ▾

Low Alarm 11 %

Low Pre-alarm Enable

Low Pre-alarm Trip 23 %

Low Pre-alarm Return 34 %

Low Alarm String Flexible Sensor F Low

High Pre-alarm Enable

High Pre-alarm Return 57 %

High Pre-alarm Trip 69 %

High Alarm Enable

Action Shutdown ▾

High Alarm 92 %

High Alarm String Flexible Sensor F High

Parameter	Description
Alarm Arming	Select when the input becomes active: Always: The input state is always monitored. From Safety On: The state of the input is monitored from the end of the <i>Safety On Delay</i> timer. From Starting: The state of the input is only monitored from engaging the crank.
Low Alarm Enable	<input type="checkbox"/> = The Alarm is disabled. <input checked="" type="checkbox"/> = The <i>Low Alarm</i> is active when the measured quantity drops below the <i>Low Alarm</i> setting.
Low Pre-Alarm Enable	<input type="checkbox"/> = The Pre-Alarm is disabled. <input checked="" type="checkbox"/> = The <i>Low Pre-Alarm</i> is active when the measured quantity drops below the <i>Low Pre-Alarm</i> setting. The <i>Low Pre-Alarm</i> is automatically reset when the measured quantity rises above the configured <i>Low Pre-Alarm Return</i> level.
High Pre-Alarm Enable	<input type="checkbox"/> = The Pre-Alarm is disabled. <input checked="" type="checkbox"/> = The <i>High Pre-Alarm</i> is active when the measured quantity rises above the <i>High Pre-Alarm</i> setting. The <i>High Pre-Alarm</i> is automatically reset when the measured quantity falls below the configured <i>High Pre-Alarm Return</i> level.
High Alarm Enable	<input type="checkbox"/> = The Alarm is disabled. <input checked="" type="checkbox"/> = The <i>High Alarm</i> is active when the measured quantity rises above the <i>High Alarm</i> setting.

2.4.3 EDITING THE SENSOR CURVE

While the *DSE Configuration Suite* holds sensor specifications for the most commonly used resistive sensors, occasionally it is required that the module be connected to a sensor not listed by the *Configuration Suite*. To aid this process, a sensor editor is provided.

The image shows a software interface for editing sensor curves. At the top, there is a section for 'Input Type' with a dropdown menu showing 'VDO Ohm range (10-180)' and an 'Edit...' button. Below this is the 'Curve Editor' window, which contains a graph with 'Temperature in: °C' on the y-axis and 'Ohms' on the x-axis. The graph shows a blue curve with several data points. A callout points to the 'Edit...' button, stating 'Click to edit the 'sensor curve''. Another callout points to the graph area, stating 'In this example, the closest match to the sensor in use is the VDO 10-180Ω fuel level sensor.' A third callout points to a point on the curve, stating 'Double click the left mouse button to add a point or right click on a point to remove it.' A fourth callout points to a point on the curve, stating 'Click and drag the points on the graphs to change the settings'. A fifth callout points to the 'Interpolate' button, stating 'Click *Interpolate* then select two points as prompted to draw a straight line between them.' A sixth callout points to the 'Change Axes Range' button, stating 'Click to change the range of the X and Y Axes of the graph.' A seventh callout points to a point on the curve, stating 'Use the mouse to select the graph point, then enter the value in the box or click up/down to change the value'. A large cloud-shaped callout contains a 'Hint: Deleting, renaming or editing custom sensor curves that have been added is performed in the main menu, select *Tools | Curve Manager*.' At the bottom of the interface, there are buttons for 'Interpolate', 'Change Axes Range', 'Save As', 'OK', and 'Cancel'. A status bar at the bottom indicates 'Number of points used: 5/31'. A large callout at the bottom left explains the 'Save As' and 'OK' buttons: 'Click SAVE AS, you are prompted to name your curve....', 'Click OK to save the curve.', and 'Any saved curves become selectable in the *Input Type* selection list.' Another callout points to the 'OK' button, stating 'Click OK to accept the changes and return to the configuration editor'. A third callout points to the 'Cancel' button, stating 'Click CANCEL to ignore and lose any changes you have made'. A final callout points to the status bar, stating 'Shows the number of points used in the curve.'

2.4.4 DIGITAL INPUTS

The *Digital Inputs* section is subdivided into smaller sections. Select the required section with the mouse.

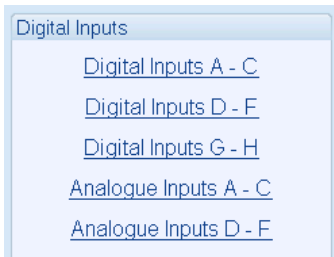

2.4.4.1 DIGITAL INPUTS

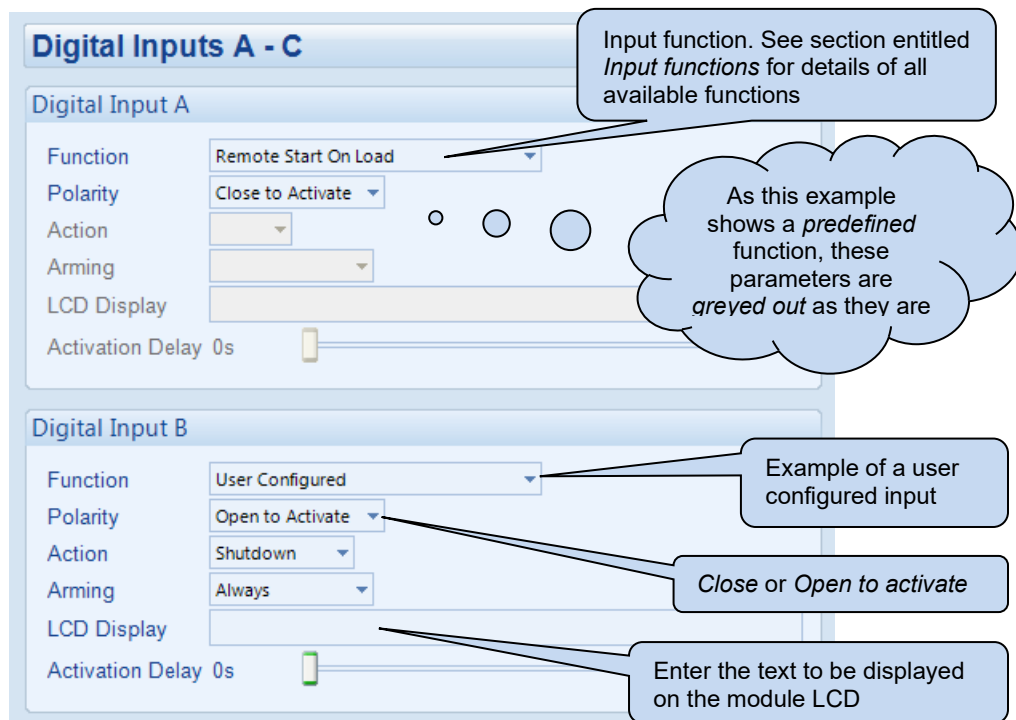

Parameter	Description
Function	Select the input function to activate when the relevant terminal is energised. See section entitled <i>Input functions</i> for details of all available functions.
Polarity	Select the digital input polarity: Close to Activate: the input function is activated when the relevant terminal is connected. Open to Activate: the input function is activated when the relevant terminal is disconnected.
Action	Select the type of alarm required from the list: Electrical Trip Shutdown Warning For details of these, see the section entitled <i>Alarm Types</i> elsewhere in this document.
Arming	Select when the input becomes active: Always: The input state is always monitored. Active From Safety On: The state of the input is monitored from the end of the <i>Safety On Delay</i> timer. Active From Starting: The state of the input is only monitored from engaging the crank Never: The input is disabled.
Activation Delay	This is used to give a delay on acceptance of the input. Useful for liquid level switches or to mask short term operations of the external switch device.

2.4.5 ANALOGUE INPUTS

Analogue Inputs A - C

Analogue Input A (Digital)

The Analogue Input is not configured as a Digital Input
To reconfigure, use the 'Analogue Input Configuration' page

Analogue Input B (Digital)

Function: User Configured
Polarity: Close to Activate
Action: Shutdown
Arming: Never
LCD Display: [Empty]
Activation Delay: 0s

Analogue Input C (Digital)

The Analogue Input is not configured as a Digital Input
To reconfigure, use the 'Analogue Input Configuration' page

Depending on selection, the configuration of the input is located in different sections in the software.

Example of an analogue input configured as digital.



2.4.6 INPUT FUNCTIONS

Where a digital input is NOT configured as “user configured”, a selection is made from a list of predefined functions. The selections are as follows:





Under the scope of IEEE 37.2, *function numbers are also used to represent functions in microprocessor devices and software programs.* Where the DSE input functions are represented by IEEE 37.2, the function number is listed below.







= Only applicable to DSE7320 MKII AMF Modules

Function	Description
Alarm Mute	This input is used to silence the audible alarm from an external source, such as a remote mute switch.
Alarm Reset	This input is used to reset any latched alarms from a remote location. It is also used to clear any latched warnings which may have occurred (if configured) without having to stop the generator.
Alt Config x Select	These inputs are used to instruct the module to follow the relevant <i>alternative</i> configuration settings instead of the <i>main</i> configuration settings.
 Auto Restore Inhibit IEEE 37.2 - 3 Checking Or Interlocking Relay	In the event of a remote start/mains failure, the generator is instructed to start and take load. On removal of the remote start signal/mains return the module continues to run the generator on load until the <i>Auto Restore Inhibit</i> input is removed. This input allows the controller to be fitted as part of a system where the restoration to mains is controlled remotely or by an automated system.
Auto Start Inhibit IEEE 37.2 - 3 Checking Or Interlocking Relay	This input is used to provide an over-ride function to prevent the controller from starting the generator in the event of a remote start/mains out of limits condition occurring. If this input is active and a remote start signal/mains failure occurs the module does not give a start command to the generator. If this input signal is then removed, the controller operates as if a remote start/mains failure has occurred, starting and loading the generator. This function is used to give an ‘AND’ function so that a generator is only called to start if the mains fails and another condition exists which requires the generator to run. If the ‘Auto start Inhibit’ signal becomes active once more it is ignored until the module has returned the mains supply on load and shutdown. This input does not prevent starting of the engine in MANUAL mode.
 Auxiliary Mains Fail	The module monitors the incoming single or three phase supply for Over voltage, Under Voltage, Over Frequency or Under frequency. It may be required to monitor a different mains supply or some aspect of the incoming mains not monitored by the controller. If the devices providing this additional monitoring are connected to operate this input, the controller operates as if the incoming mains supply has fallen outside of limits, the generator is instructed to start and take the load. Removal of the input signal causes the module to act if the mains has returned to within limits providing that the mains sensing also indicates that the mains is within limits.
Close Generator IEEE 37.2 - 52 AC Circuit Breaker	Closes the Generator load switch when the generator is available. Used to simulate the <i>Close Generator Breaker</i> button externally.
Coolant Temperature Switch IEEE 37.2 – 26 Apparatus Thermal Device	This input is used to give a <i>Coolant Temperature High</i> shutdown from a digital normally open or closed switch. It allows coolant temperature protection.
Disable Protections	The system designer provides this switch (not DSE) so its location varies depending upon manufacturer, however it normally takes the form of a key operated switch to prevent inadvertent activation. Depending upon configuration, a warning alarm is generated when the switch is operated. When active, and the module is suitably configured (see section entitled ‘Advanced’) this prevents the engine being stopped upon critical alarm (Sometimes called Battle-Short Mode, War Mode or Run to Destruction.)

Function	Description
DPF Auto Regen Inhibit	This input is used to override the ECU (ECM) function and prevent the automatic regeneration of the diesel particulate filter.
DPF Force Regeneration	This input is used to override the ECU (ECM) function and activate the regeneration of the diesel particulate filter.
DPF Regeneration Interlock	This input is used to stop a manual regeneration from occurring.
Droop Enable	This input is used to switch the engine into droop mode on CAN engines that support this function.
Dual Mutual Standby	This input activates the <i>Dual Mutual Standby</i> functionality. This is described fully in the section entitled <i>Module</i> elsewhere in this manual.
ECU Specific 1,2,3	These inputs are used with some supported engine files only for electronic CAN engines. They are used to instruct the engine file to perform certain function controls on the engine without the need to change a configuration on the module. Activating the relevant input allows the engine file to exercise a special operation on the engine.
EJP1	For the French EJP (Effacement Jours de Pointe) tariff system. This input is functionally identical to <i>Remote Start Off Load</i> . When this input is active, operation is similar to the 'Remote Start on load' function except that the generator is not instructed to take the load. This function is also used where an engine only run is required e.g. for exercise.
EJP2	For the French EJP (Effacement Jours de Pointe) tariff system. This input is functionally identical to <i>Remote Start On Load</i> . In auto mode, the module performs the start sequence and transfers load to the generator. In Manual mode, the load is transferred to the generator if the engine is already running, however in manual mode, this input does not generate start/stop requests of the engine.
Escape Mode	This input function is supported on specific new engines for Maintenance / Regeneration requirements, used when the engine is running off-load. When the Escape Mode input is active, some of the CAN engine alarms are overridden to restore the engine in alarm free mode at no load, to provide a specific maintenance / regeneration type operation to the CAN engine.
External Panel Lock	 NOTE: External control sources (i.e. Simulate Start Button) are not affected by the external panel lock input and continue to operate normally. This input is used to provide security to the installation. When the External Panel lock input is active, the module does not respond to operation of the Mode select or Start buttons. This allows the module to be placed into a specific mode (such as Auto) and then secured. The operation of the module is not affected and the operator is still able to view the various instrumentation pages etc. (<i>Front panel configuration access is still possible while the system lock is active</i>).
Fuel Tank Bund Level High	This input is used to provide protection against fuel leakage, where a level switch is fitted to the fuel tank bund. The action for this alarm is configurable under the <i>Engine Protections</i> page in the module configuration.
Generator Closed Auxiliary IEEE 37.2 - 3 Checking or Interlocking Relay	This input is used to provide feedback to allow the module to give true indication of the contactor or circuit breaker switching status. It must be connected to the generator load switching device auxiliary contact.

Function	Description
Generator Load Inhibit IEEE 37.2 - 52 AC Circuit Breaker	<p> NOTE: This input only operates to control the generator-switching device if the module load switching logic is attempting to load the generator. It does not control the generator switching device when the mains supply is on load.</p> <p>This input is used to prevent the module from loading the generator. If the generator is already on load, activating this input causes the module to unload the generator. Removing the input allows the generator to be loaded again.</p>
Inhibit Scheduled Run IEEE 37.2 - 3 Checking Or Interlocking Relay	This input is used to provide a mean of disabling a scheduled run.
Inhibit SMS Remote Start	This input is used to provide a means of disabling remote starts by SMS.
Lamp Test	This input is used to provide a test facility for the front panel indicators fitted to the module. When the input is activated all LEDs illuminate.
Low Fuel Level Switch IEEE 37.2 - 71 Liquid Level Switch	This input is used to allow feedback for low fuel level.
Main Config Select	This input is used to select the <i>Main</i> configuration when <i>Alternative Configurations</i> are enabled.
Mains Closed Auxiliary IEEE 37.2 - 3 Checking or Interlocking Relay 	This input is used to provide feedback to allow the module to give true indication of the contactor or circuit breaker switching status. It is connected to the mains load switching device auxiliary contact. Incorrect application of this signal does not trigger an alarm condition, it is used solely for indication of the load switch status.
Mains Load Inhibit IEEE 37.2 - 3 Checking or Interlocking Relay 	<p> NOTE: This input only operates to control the mains switching device if the module load switching logic is attempting to load the mains. It does not control the mains switching device when the generator is on load.</p> <p>This input is used to prevent the module from loading the mains supply. If the mains supply is already on load activating this input causes the module to unload the mains supply. Removing the input allows the mains to be loaded again.</p>
Manual Breaker Mode	When breaker control is set to <i>Active On Input</i> , this input is used to activate the <i>Manual Breaker Control</i> .
Manual Restore Contact IEEE 37.2 - 3 Checking or Interlocking Relay 	Used to 'hold off' transfer back to the mains after a mains failure and keep the generator on load. Transfer back to the mains supply is held off in <i>Auto mode</i> while the input is present. Typically, a key switch provides this input with <i>spring return to closed</i> functionality.
Oil Pressure Switch IEEE 37.2 - 63 Pressure Switch	A digital normally open or closed oil pressure switch gives this input. It allows low oil pressure protection.
Open Generator IEEE 37.2 - 52 AC circuit breaker	Opens the generator breaker. Used to simulate the <i>Open Generator Breaker</i> button externally.
Remote Start Off Load	If this input is active, operation is similar to the 'Remote Start on load' function except that the generator is not instructed to take the load. This function is used where an engine only run is required e.g. for exercise.
Remote Start On Load	When in auto mode, the module performs the start sequence and transfer load to the generator. In Manual mode, the load is transferred to the generator if the engine is already running, however in manual mode, this input does not generate start/stop requests of the engine.
Reset Maintenance Alarm 1	Provides an external digital input to reset the maintenance alarm 1.
Reset Maintenance Alarm 2	Provides an external digital input to reset the maintenance alarm 2.
Reset Maintenance Alarm 3	Provides an external digital input to reset the maintenance alarm 3.

Function	Description
Simulate Auto Button	<p> NOTE: If a call to start is present when AUTO MODE is entered, the starting sequence begins. Call to Start comes from a number of sources depending upon module type and configuration and includes (but is not limited to) : Remote start input present, Mains failure, Scheduled run, Auxiliary mains failure input present, Telemetry start signal from remote locations.</p> <p>This input mimics the operation of the 'Auto' button and is used to provide a remotely located Auto mode push button.</p>
Simulate Lamp Test Button	This input is used to provide a test facility for the front panel indicators fitted to the module. When the input is activated all LED's illuminate. The input also serves a second function, in that it also provides a mute signal to silence the audible alarm. The input is recognised by the module as though it was the Push button on the module itself being operated.
 Simulate Mains Available	This function is provided to override the module's internal monitoring function. If this input is active, the module does not respond to the state of the incoming AC mains supply.
Simulate Manual Button	This input mimics the operation of the 'Manual' button and is used to provide a remotely located Manual mode push button.
Simulate Start Button	This input mimics the operation of the 'Start' button and is used to provide a remotely located start push button.
Simulate Stop Button	This input mimics the operation of the 'Stop' button and is used to provide a remotely located stop/reset push button.
Simulate Test on load button	This input mimics the operation of the 'Test' button and is used to provide a remotely located Test on load mode push button.
Smoke Limiting IEEE 37.2 – 18 Accelerating or Decelerating Device	This input instructs the module to give a <i>run at idle speed</i> command to the engine either via an output configured to <i>smoke limit</i> or by data commands when used with supported electronic engines.
Start in Manual Mode	Combined function input that instructs the module to enter MANUAL MODE and also perform the <i>START</i> function. Once the input is active, the module is placed into manual mode and the generator starts.
Stop and Panel Lock	<p>Combined function input that instructs the module to enter STOP mode and also perform the <i>Panel Lock</i> function. Once the input is active, the module does not respond to operation of the mode select or start buttons.</p> <p>The operator is still able to view the various instrumentation pages etc. (<i>Front panel configuration access is still possible while the system lock is active</i>).</p>
 Transfer To Generator/Open Mains IEEE 37.2 - 52 AC Circuit Breaker	This input is used to transfer the load to the generator when running in MANUAL MODE.
 Transfer To Mains/ Open Generator IEEE 37.2-52 AC Circuit Breaker	This input is used to transfer the load to the mains supply when running in MANUAL MODE.
Water in Fuel	<p>Some engines are fitted with water separators, that have a switch indicator for water detection.</p> <p>This input is used to provide protection against high water content in the fuel, where a switch is fitted to the fuel filter. The action for this alarm is configurable under the <i>Engine Protections</i> page in the module configuration.</p>

2.5 OUTPUTS

The *Outputs* section is subdivided into smaller sections. Select the required section with the mouse.

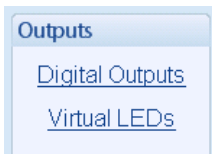

2.5.1 DIGITAL OUTPUTS

Parameter	Description
Source	Select the output source to control the state of the output. See section entitled <i>Output Sources</i> for details of all available functions.
Polarity	Select the digital output polarity: De-Energise: When the output source is true, the output deactivates. Energise: When the output source is true, the output activates.

2.5.2 VIRTUAL LEDS

The virtual LEDs provide a configuration of 'status' items. These items are not available for viewing on the module but are seen in the SCADA section of the PC software or read by third party systems (i.e. BMS or PLCs) using the Modbus protocol.

Virtual LEDs

LED Configuration

	Source	Polarity
LED 1	Not Used	Lit
LED 2	Not Used	Lit
LED 3	Not Used	Lit
LED 4	Not Used	Lit
LED 5	Not Used	Lit
LED 6	Not Used	Lit
LED 7	Not Used	Lit
LED 8	Not Used	Lit
LED 9	Not Used	Lit
LED 10	Not Used	Lit
LED 11	Not Used	Lit
LED 12	Not Used	Lit
LED 13	Not Used	Lit
LED 14	Not Used	Lit
LED 15	Not Used	Lit
LED 16	Not Used	Lit
LED 17	Not Used	Lit
LED 18	Not Used	Lit
LED 19	Not Used	Lit
LED 20	Not Used	Lit

Parameter	Description
Source	Select the output source to control the state of the output. See section entitled <i>Output Sources</i> for details of all available functions.
Polarity	Select the digital input polarity: Lit: When the output source is true, the virtual LED activates. Unlit: When the output source is true, the virtual LED deactivates.

2.5.3 OUTPUT SOURCES

The list of output sources available for configuration of the module digital outputs.



Under the scope of IEEE 37.2, *function numbers are also used to represent functions in microprocessor devices and software programs*. Where the DSE output functions is represented by IEEE 37.2, the function number is listed below.

The outputs are in alphabetical order with the *parameter* first. For instance for over frequency output, it's listed as *Generator Over Frequency*.



= Only available on DSE7320 MKII AMF Modules

Output Source	Activates...	Is Not Active...
Not Used	The output does not change state. (Unused)	
Air Flap Relay	Normally used to control an air flap, this output becomes active upon an Emergency Stop or Over-speed situation.	Inactive when the set has come to rest.
Alarm Mute	This input is used to silence the audible alarm from an external source such as a remote mute switch.	
Alarm Reset	This input is used to reset any latched alarms from a remote location. It is also used to clear any latched warnings which may have occurred (if configured) without having to stop the engine.	
Alternative Config 1, 2, 3, 4, 5 Selected	Active when the alternative configuration is selected.	
Analogue Input A,B,C,D,E,F (Digital)	Active when the analogue input A,B,C,D,E,F configured to digital is active.	
Arm Safety On Alarms	Becomes active at the end of the <i>safety delay</i> timer whereupon all alarms configured to 'From Safety On' become active.	Inactive when : <ul style="list-style-type: none"> • When the set is at rest. • In the starting sequence before the Safety Delay timer has expired.
Audible Alarm IEEE 37.2 – 74 Alarm Relay	Use this output to activate an external sounder or external alarm indicator. Operation of the Mute pushbutton resets this output once activated.	Inactive if no alarm condition is active or if the Mute pushbutton was pressed.
Auto Restore Inhibit	Active when the <i>Auto Restore Inhibit</i> digital input is active.	
Auto Start Inhibit	Active when the <i>Auto-Start Inhibit</i> function is active.	
Auxiliary Mains Fail	Active when the <i>Auxiliary Mains Fail</i> input function is active.	
AVR Data Fail	Active when the <i>AVR Data Fail</i> alarm is active, indicating communication failure with the CAN AVR.	
AVR Fault	Active when the <i>AVR Fault</i> alarm is active, indicating an alarm detection on the CAN AVR.	
Battery High Voltage IEEE 37.2 – 59 DC Overvoltage Relay	This output indicates that a Battery Over voltage alarm has occurred.	Inactive when battery voltage is not High.
Battery Low Voltage IEEE 37.2 – 27 DC Undervoltage Relay	This output indicates that a Battery Under Voltage alarm has occurred.	Inactive when battery voltage is not Low.
Calling For Scheduled Run	Active during a <i>Scheduled Run</i> request from the inbuilt <i>Scheduler</i> .	
CAN ECU Data Fail	Becomes active when no CAN data is received from the ECU after the safety delay timer has expired.	Inactive when: <ul style="list-style-type: none"> • CAN data is being received. • The set is at rest • During the starting sequence before the safety delay timer has expired
CAN ECU Power	Used to switch an external relay to power the CAN ECU (ECM). Exact timing of this output is dependent upon the type of the engine ECU. (ECM)	



Output Source	Activates...	Is Not Active...
CAN ECU Shutdown	The engine ECU (ECM) has indicated that a Shutdown alarm is present.	Inactive when no Shutdown alarm from the ECU (ECM) is present.
CAN ECU Stop	Active when the DSE controller is requesting that the CAN ECU (ECM) stops the engine.	
CAN ECU Warning	The engine ECU (ECM) has indicated that a Warning alarm is present.	Inactive when no Warning alarm from the ECU (ECM) is present.
Charge Alternator Failure Shutdown	Active when the charge alternator shutdown alarm is active.	
Charge Alternator Failure Warning	Active when the charge alternator warning alarm is active.	
Sync Check	Active when the <i>Sync Check</i> is active during the generator to mains transition.	
Clock Pulse	Also called 'heartbeat', it activates and deactivates every few milliseconds to indicate that the module is powered up. It stops energising during write configuration to the module.	
Close Gen Output IEEE 37.2 – 52 AC Circuit Breaker	Used to control the load switching device. Whenever the module selects the generator to be on load this control source is activated.	Inactive whenever the generator is not required to be on load.
Close Gen Output Pulse IEEE 37.2 – 52 AC Circuit Breaker	Used to control the load switching device. Whenever the module selects the generator to be on load this control source is activated for the duration of the Breaker Close Pulse timer, after which it becomes inactive again.	
Close Mains Output IEEE 37.2 – 52 AC Circuit Breaker 	Used to control the load switching device. Whenever the module selects the mains to be on load this control source is activated.	The output is inactive whenever the mains is not required to be on load.
Close Mains Output Pulse IEEE 37.2 – 52 AC Circuit Breaker 	Used to control the load switching device. Whenever the module selects the mains to be on load this control source is activated for the duration of the Breaker Close Pulse timer, after which it becomes inactive again.	
Combined Mains Failure 	Active when the mains supply is out of limits OR the input for Auxiliary Mains Failure is active.	
Combined Maintenance Alarm	Active when any of the maintenance alarm is active.	
Combined Under and Over Frequency Alarm	Active when an <i>Under-Frequency</i> or <i>Over-Frequency Shutdown</i> alarm is active.	
Combined Under and Over Frequency Warning	Active when an <i>Under-Frequency</i> or <i>Over-Frequency Warning</i> alarm is active.	
Combined Under and Over Voltage Alarm	Active when an <i>Under-Voltage</i> or <i>Over-Voltage Shutdown</i> alarm is active.	
Combined Under and Over Voltage Warning	Active when an <i>Under-Voltage</i> or <i>Over-Voltage Warning</i> alarm is active.	
Common Alarm	Active when one or more alarms (of any type) are active.	The output is inactive when no alarms are present.
Common Electrical Trip	Active when one or more <i>Electrical Trip</i> alarms are active.	The output is inactive when no shutdown alarms are present.
Common Shutdown	Active when one or more <i>Shutdown</i> alarms are active.	The output is inactive when no shutdown alarms are present.
Common Warning	Active when one or more <i>Warning</i> alarms are active.	The output is inactive when no warning alarms are present.
Configurable CAN x Instrument Active	Active when the relevant <i>Configurable CAN Instrumentation</i> alarm of the <i>Received Instrumentation (1-10)</i> is active.	
Coolant Cooler Control	Active by the <i>Coolant Cooler Control</i> in conjunction with the Coolant Temperature Sensor.	
Coolant Heater Control	Active by the <i>Coolant Heater Control</i> in conjunction with the Coolant Temperature Sensor.	
Coolant Temperature Switch IEEE 37.2 – 26 Apparatus Thermal Device	Active when the <i>Coolant Temperature Switch</i> input is active.	
Cooling Down	Active when the Cooling timer is in progress.	

Output Source	Activates...	Is Not Active....
Data Logging Active	Active when data is being logged.	Inactive when: <ul style="list-style-type: none"> Data logging is disabled The engine is at rest and the option <i>Only Log When Engine Is Running</i> is enabled The internal memory of the module becomes full and the option <i>Keep Oldest Data</i> is enabled
DEF Level Low	Active when <i>DEF Level Low</i> CAN alarm is active	
DEF Level Low Alarm	Active when <i>DEF Level Low Alarm</i> is active	
Digital Input A, B, C, D, E, F, G & H	Active when the relevant digital input is active	
Display Heater Fitted and On	Active when the display heater is on	
DPF Forced Regeneration Requested	Active when the <i>DPF Force Regeneration</i> is active	
DPF Non Mission State	Active when the <i>DPF Non-Mission State</i> is active	
DPF Regeneration In Progress	Active when the <i>DPF Regeneration</i> is in progress	
DPF Regeneration Interlock Active	Active when the <i>DPF Regeneration Interlock</i> is active	
DPTC Filter	Active when the diesel particulate filter CAN alarm is active	
Droop Enable	Active when an input configured to <i>Droop Enable</i> is active or if <i>Droop Enable</i> has been activated in the module configuration (CAN engine only)	
Dual Mutual Active	Active when the <i>Dual Mutual Standby</i> is active	
Dual Mutual Input	Active when the <i>Dual Mutual Standby</i> digital input is active	
Dual Mutual On Load	Active when the generator is running due to <i>Dual Mutual Standby</i>	
Dual Mutual Standby	Active when the generator is in standby in <i>Dual Mutual Standby</i>	
Dummy Load Control (1-5)	Becomes active when the engine kW falls below the Dummy Load Control Trip Setting.	Inactive when the engine kW returns to above the Dummy Load Control Return setting.
Earth Fault Trip Alarm IEEE 37.2 – 51G or 51N Generator IDMT Earth Fault Relay	Active when the <i>Earth Fault Protection Alarm</i> is active.	
ECU (ECM) Data Fail	Becomes active when no CAN data is received from the ECU after the safety delay timer has expired	Inactive when: <ul style="list-style-type: none"> CAN data is being received The set is at rest During the starting sequence before the safety delay timer has expired
ECU (ECM) Power	Used to switch an external relay to power the CAN ECU (ECM). Exact timing of this output is dependent upon the type of the engine ECU (ECM)	
ECU (ECM) Shutdown	The engine ECU (ECM) has indicated that a Shutdown alarm is present.	Inactive when no Shutdown alarm from the ECU (ECM) is present
ECU (ECM) Stop	Active when the DSE controller is requesting that the CAN ECU (ECM) stops the engine.	
ECU (ECM) Warning	The engine ECU (ECM) has indicated that a Warning alarm is present.	Inactive when no Warning alarm from the ECU (ECM) is present
ECU Pre-Heat	Active when the <i>ECU Pre-Heat</i> is active.	
ECU Specific 1,2,3	Active when the relevant <i>ECU Specific</i> input is active.	
EJP1 / EJP2	Active when an input configured for <i>EJP1</i> or <i>EJP2</i> is active	
Emergency Stop IEEE 37.2 – 5 Stopping Device	Active when the <i>Emergency Stop</i> input has been activated	

Output Source	Activates...	Is Not Active....
Energise To Stop	Normally used to control an <i>Energise to Stop</i> solenoid, this output becomes active when the controller wants the set to stop running.	Becomes inactive a configurable amount of time after the set has stopped. This is the <i>ETS hold time</i> .
Escape Mode	Active when <i>Escape Mode</i> function is active through a digital input or from the module's Running Editor.	
External Panel Lock	Active when the <i>External Panel Lock</i> digital input is active	
Fail to Close Generator IEEE 37.2 – 52B AC Circuit Breaker Position (Contact Open When Breaker Closed)	Active when the <i>Generator Closed Auxiliary</i> input fails to become active after the <i>Close Generator Output</i> or <i>Close Generator Output Pulse</i> becomes active	
Fail to Close Mains IEEE 37.2 – 52B AC Circuit Breaker Position (Contact Open When Breaker Closed)	Active when the <i>Mains Closed Auxiliary</i> input fails to become active after the <i>Close Mains Output</i> or <i>Close Mains Output Pulse</i> becomes active	
Fail To Start IEEE 37.2 - 48 Incomplete Sequence Relay	Becomes active if the set is not seen to be running after the configurable number of start attempts	
Fail To Stop IEEE 37.2 - 48 Incomplete Sequence Relay	If the set is still running a configurable amount of time after it has been given the stop command, the output becomes active. This configurable amount of time is the <i>Fail to Stop Timer</i> .	
Fail To Synchronise	Active when the <i>Fail to Sync Alarm</i> is active	
Fan Control	Energises when the engine becomes available (up to speed and volts). This output is designed to control an external cooling fan. When the engine stops, the cooling fan remains running for the duration of the Fan Overrun Delay.	
Flexible Sensor A, B, C, D, E or F High Alarm	Active when the analogue input value rises above the <i>Flexible Sensor High Alarm</i> set point.	
Flexible Sensor A, B, C, D, E or F High Pre-Alarm	Active when the analogue input value rises above the <i>Flexible Sensor High Pre-Alarm</i> set point.	
Flexible Sensor A, B, C, D, E or F Low Alarm	Active when the analogue input value falls below the <i>Flexible Sensor Low Alarm</i> set point.	
Flexible Sensor A, B, C, D, E or F Low Pre-Alarm	Active when the analogue input value falls below the <i>Flexible Sensor Low Pre-Alarm</i> set point.	
Flexible Sensor A, B, C, D, E or F Open Circuit	Active when the <i>Flexible Sensor Open Circuit</i> alarm becomes active.	
Fuel Level High Alarm	Active when the High Fuel Level Alarm is active.	
Fuel Level High Pre-Alarm	Active when the High Fuel Level Pre-Alarm is active.	
Fuel Level Low Alarm	Active when the Low Fuel Level Alarm is active.	
Fuel Level Low Pre-Alarm	Active when the Low Fuel Level Pre-Alarm is active.	
Fuel Pump Control IEEE 37.2 – 71 Level Switch	Becomes active when the <i>Fuel level</i> falls below the <i>Fuel Pump Control ON</i> setting and is normally used to transfer fuel from the bulk tank to the day tank.	If the output is already active it becomes inactive when the <i>Fuel level</i> is above the <i>Fuel Pump Control OFF</i> settings.
Fuel Relay	Becomes active when the controller requires the governor/fuel system to be active.	Becomes inactive whenever the set is to be stopped, including between crank attempts, upon controlled stops and upon fault shutdowns.
Fuel Sensor Open Circuit	Active when the <i>Fuel Sensor Open Circuit</i> alarm becomes active	
Fuel Tank Bund Level High	Active when the <i>Fuel Bund Level High Alarm</i> input is active.	
Fuel Usage Alarm IEEE 37.2 – 80 Flow Switch	Active when the <i>Fuel Usage</i> alarm becomes active	
Gas Choke On	Becomes active during starting for the duration of the Gas Choke timer. Normally used to choke a gas engine.	Inactive at all other times
Gas Ignition	Becomes active during starting.	Becomes inactive a configurable amount of time after the <i>Fuel Relay</i> becomes inactive. This is the <i>Gas Ignition Off</i> timer.

Output Source	Activates...	Is Not Active....
Gen Loading Frequency Not Reached	Indicates that the generator frequency has not reached the configured <i>Loading Frequency</i> during the starting process.	
Gen Loading Voltage Not Reached	Indicates that the generator voltage has not reached the configured <i>Loading Voltage</i> during the starting process.	
Gen Over Frequency Overshoot Alarm IEEE 37.2 – 81 Frequency Relay	Becomes active when the <i>Over Frequency Overshoot</i> alarm is active	
Gen Over Frequency Overshoot Warning IEEE 37.2 – 81 Frequency Relay	Becomes active when the <i>Over Frequency Overshoot Warning</i> alarm is active	
Generator Available	Becomes active when the generator is available to take load.	Inactive when <ul style="list-style-type: none"> • <i>Loading voltage</i> and <i>loading frequency</i> have not been reached • After <i>electrical trip</i> alarm • During the starting sequence before the end of the warming timer.
Generator Closed Aux	Active when the <i>Generator Closed Auxiliary</i> input is active	
Generator Excite IEEE 37.2 – 31 Separate Excitation Device	Used to control the excitation of the main alternator (AC).	Becomes inactive when the set is stopped.
Generator High Voltage Alarm IEEE 37.2 – 59 AC Overvoltage Relay	Active when the <i>High Voltage Electrical Trip</i> alarm is active	
Generator High Voltage Warning IEEE 37.2 – 59 AC Overvoltage Relay	Active when the <i>High Voltage Warning</i> alarm is active	
Generator High Volts Shutdown IEEE 37.2 – 59 AC Overvoltage Relay	Active when the <i>High Voltage Shutdown</i> alarm is active	
Generator Load Inhibit	Active when the <i>Generator Load Inhibit</i> input is active	
Generator Low Voltage Shutdown/Electrical Trip IEEE 37.2 – 27 AC Undervoltage Relay	Active when the generator voltage falls below the <i>Low Voltage Alarm Trip</i> level	Inactive when <ul style="list-style-type: none"> • The set is stopped • During starting sequence before the safety delay time has expired.
Generator Low Voltage Warning IEEE 37.2 – 27 AC Undervoltage Relay	Active when the generator voltage falls below the <i>Low Voltage Pre-Alarm Trip</i> level	Inactive when <ul style="list-style-type: none"> • The set is stopped • During starting sequence before the safety delay time has expired.
Generator Over Frequency Alarm IEEE 37.2 – 81 Frequency Relay	Active when the generator frequency exceeds the <i>Over Frequency Shutdown Trip</i> level.	
Generator Over Frequency Delayed Alarm IEEE 37.2 – 81 Frequency Relay	Active when the generator frequency exceeds the configured <i>Over Frequency Shutdown Trip</i> level for a duration longer than the set <i>Overshoot Delay</i> timer.	
Generator Over Frequency Delayed Warning IEEE 37.2 – 81 Frequency Relay	Active when the generator frequency exceeds the configured <i>Over Frequency Warning Trip</i> level for a duration longer than the set <i>Overshoot Delay</i> timer.	
Generator Phase Rotation Alarm IEEE 37.2 – 47 Phase Sequence Relay	Active when the detected generator phase sequence is different than the configured <i>Generator Phase Rotation</i>	
Generator Reverse Power IEEE 37.2 – 32 Directional Power Relay	Active when the <i>Generator Reverse Power</i> alarm is active	

Output Source	Activates...	Is Not Active....
HEST Active	Active when the High Exhaust System Temperature CAN alarm is active	
High Coolant Temperature Electrical Trip IEEE 37.2 – 26 Apparatus Thermal Device	Active when the <i>Coolant Temperature</i> exceeds the configured <i>High Coolant Temperature Electrical Trip</i> level	
High Coolant Temperature Shutdown IEEE 37.2 – 26 Apparatus Thermal Device	Active when the <i>Coolant Temperature</i> exceeds the configured <i>High Coolant Temperature Shutdown</i> level	
High Coolant Temperature Warning IEEE 37.2 – 26 Apparatus Thermal Device	Active when the <i>Coolant Temperature</i> exceeds the configured <i>High Coolant Temperature Warning</i> level	
High Inlet Temperature Shutdown	Active when the High Inlet Temperature Shutdown is active on the module.	
High Inlet Temperature Warning	Active when the High Inlet Temperature Warning is active on the module.	
Inhibit Scheduled run	Active when the Inhibit Scheduled run input is active	
Inhibit SMS Start	Active when the input Inhibit SMS Start input is active	
Interlock Override 	This function is used to bypass the generator and mains breakers' electrical interlock during the <i>Closed Transition</i> to allow short term paralleling. This output becomes active when the <i>Synchronisation Delay</i> activates and remains active until the <i>Interlock Override Off</i> timer is terminated.	
kW Overload Alarm	Active when the measured kW is above the setting of the <i>kW overload alarm</i> . Used to give alarms on overload, control a dummy load switch or for load shedding functionality.	
Lamp Test	Active when the lamp test is activated by a digital input or by pressing the <i>Mute/Lamp Test</i> control button	
Load Shedding Control (1-5)	Becomes active when the engine kW exceeds Load Shedding Control Trip Setting.	Inactive when the engine kW returns to below the Load Shedding Control Return setting.
Loading Frequency Not Reached	Active when the generator frequency has not reached the configured <i>Loading Frequency</i> during the starting process.	
Loading Voltage Not Reached	Active when the generator voltage has not reached the configured <i>Loading Voltage</i> during the starting process.	
Loss of Mag Pickup Signal	Active when the controller senses the loss of signal from the magnetic pickup probe	
Louvre Control	Active when the fuel relay becomes active. Normally used to drive ventilation louvres for the generator set	
Low Coolant Temperature IEEE 37.2 – 26 Apparatus Thermal Device	Active when the <i>Coolant Temperature</i> falls below the <i>Low Coolant Temperature alarm</i> setting	
Low Load	Active when the Low Load alarm is active.	
Low Fuel Level IEEE 37.2 – 71 Level Switch	Active when the <i>Low Fuel Level</i> alarm becomes active	
Low Oil Pressure Shutdown IEEE 37.2 - 63 Pressure Switch	Active when the <i>Oil Pressure</i> falls below the <i>Low Oil Pressure Shutdown</i> setting	Inactive when <ul style="list-style-type: none"> The set is stopped During starting sequence before the safety delay time has expired.
Low Oil Pressure Warning IEEE 37.2 - 63 Pressure Switch	Active when the <i>Oil Pressure</i> falls below the <i>Low Oil Pressure Warning</i> setting	Inactive when <ul style="list-style-type: none"> The set is stopped During starting sequence before the safety delay time has expired.
Main Config Selected	Active when the main configuration is active	
Mains Closed Aux	Active when the <i>Mains Closed Auxiliary</i> input is active	

Output Source	Activates...	Is Not Active....
Mains Failure IEEE 37.2 - 81 Frequency Relay IEEE 37.2 – 27 AC Undervoltage Relay IEEE 37.2 – 59 AC Overvoltage Relay 	The output indicates that one or more of the module's sources of determining mains failure is active.	
Mains High Frequency IEEE 37.2 -81 Frequency Relay	Active when the mains frequency exceeds the <i>High Frequency</i> setting	
Mains High Voltage IEEE 37.2 – 59 AC Overvoltage Relay	Active when the mains voltage exceeds the <i>High Voltage</i> setting	
Mains Load Inhibit	Active when the <i>Mains Load Inhibit</i> input is active	
Mains Low Frequency IEEE 37.2 -81 Frequency Relay	Active when the mains frequency falls below the <i>Low Frequency</i> setting	
Mains Low Voltage IEEE 37.2 – 27 AC Undervoltage Relay	Active when the mains voltage falls below the <i>Low Voltage</i> setting	
Mains Phase Rotation Alarm	Active when the detected mains phase sequence is different than the configured <i>Mains Phase Rotation</i>	
Maintenance Alarm 1, 2 or 3 Due	Active when the relevant maintenance alarm is due.	
Manual Restore Contact	Active when the manual restore contact input is active	
MPU Open circuit	This output indicates that the module has detected an open circuit failure in the Magnetic Pickup transducer circuit.	
MSC Compatibility	Active when the <i>MSC Compatibility</i> alarm is active	
MSC Failure	Active when the <i>MSC Failure</i> alarm is active	
MSC ID Error	Active when the <i>MSC ID Error</i> alarm is active	
MSC Priority Error	Active when the <i>MSC Priority Error</i> alarm is active	
Negative Phase Sequence Alarm	Active when the <i>Negative Phase Sequence</i> alarm is active	
Negative VAr Alarm IEEE 37.2 – 40 Field Under Excitation Relay	Active when the negative VAr falls below the configured Generator <i>Negative VAr Alarm</i> level for a duration longer than the set <i>Delay</i> timer	
Negative VAr Warning IEEE 37.2 – 40 Field Under Excitation Relay	Active when the negative VAr falls below the configured Generator <i>Negative VAr Pre-Alarm</i> level for a duration longer than the set <i>Delay</i> timer	
Oil Pressure Sensor Open Circuit	Active when the <i>Oil Pressure Sensor</i> is detected as being open circuit.	
Oil Pressure Switch	Active when the oil pressure switch input is active	
Open Gen Output IEEE 37.2 – 52 AC Circuit Breaker	Used to control the load switching device. Whenever the module selects the generator to be off load this control source is activated.	Inactive whenever the generator is required to be on load
Open Gen Output Pulse IEEE 37.2 – 52 AC Circuit Breaker	Used to control the load switching device. Whenever the module selects the generator to be off load this control source is activated for the duration of the Breaker Open Pulse timer, after which it becomes inactive again.	
Open Mains Output IEEE 37.2 – 52 AC Circuit Breaker 	Used to control the load switching device. Whenever the module selects the mains to be off load this control source is activated.	The output is inactive whenever the mains is required to be on load
Open Mains Output Pulse IEEE 37.2 – 52 AC Circuit Breaker 	Used to control the load switching device. Whenever the module selects the mains to be off load this control source is activated for the duration of the Breaker Open Pulse timer, after which it becomes inactive again.	
Over Current IDMT Alarm	Active when the <i>Over Current IDMT</i> alarm is active	
Over Current Immediate Warning	Active when the <i>Over Current Immediate Warning</i> alarm is active	

Output Source	Activates...	Is Not Active....
Over Frequency Runaway IEEE 37.2 -81 Frequency Relay	Active when the <i>Over Frequency Runaway</i> alarm is active	
Over Frequency Warning IEEE 37.2 -81 Frequency Relay	Active when the <i>Over Frequency Warning</i> alarm is active	
Over Speed Runaway IEEE 37.2 – 12 Over Speed Device	Active when the <i>Over Speed Runaway</i> alarm is active	
Over Speed Shutdown IEEE 37.2 – 12 Over Speed Device	Active when the <i>Over Speed Shutdown</i> alarm is active	
Over Speed Warning IEEE 37.2 – 12 Over Speed Device	Active when the <i>Over Speed Warning</i> alarm is active	
Overspeed Delayed Alarm IEEE 37.2 – 12 Over Speed Device	Active when the <i>Over Speed Delayed</i> alarm is active	
Overspeed Delayed Warning IEEE 37.2 – 12 Over Speed Device	Active when the <i>Over Speed Delayed Warning</i> alarm is active	
Over Speed Overshoot Alarm IEEE 37.2 – 12 Over Speed Device	Active when the <i>Over Speed Overshoot</i> alarm is active	
Overspeed Overshoot Warning IEEE 37.2 – 12 Over Speed Device	Active when the <i>Over Speed Overshoot Warning</i> alarm is active	
PLC Output Flag 1-100	Active when the <i>PLC Flag</i> is active	
Positive VAr Alarm	Active when the positive VAr exceeds the configured Generator <i>Positive VAr Alarm</i> level for a duration longer than the set <i>Delay</i> timer	
Positive VAr Warning	Active when the positive VAr exceeds the configured Generator <i>Positive VAr Pre-Alarm</i> level for a duration longer than the set <i>Delay</i> timer	
Preheat During Preheat Timer	Becomes active when the preheat timer begins. Normally used to control the engine preheat glow-plugs.	Inactive when : <ul style="list-style-type: none"> • The set is stopped • The preheat timer has expired
Preheat Until End Of Cranking	Becomes active when the preheat timer begins. Normally used to control the engine preheat glow-plugs.	Inactive when : <ul style="list-style-type: none"> • The set is stopped • The set has reached <i>crank disconnect</i> conditions
Preheat Until End Of Safety Timer	Becomes active when the preheat timer begins. Normally used to control the engine preheat glow-plugs.	Inactive when : <ul style="list-style-type: none"> • The set is stopped • The set has reached the end of the <i>safety delay</i> timer
Preheat Until End of Warming Timer	Becomes active when the preheat timer begins. Normally used to control the engine preheat glow-plugs.	Inactive when : <ul style="list-style-type: none"> • The set is stopped • The set has reached the end of the <i>warming</i> timer
Protections Disabled	Active when protections are turned off (Unticked) in the configuration.	
Remote Control 1-10	A series of output sources that are controlled by remote control in the SCADA section of the software, used to control external circuits.	
Remote start Off Load	Active when the <i>Remote Start Off Load</i> input is active	
Remote Start On Load	Active when the <i>Remote Start On Load</i> input is active	
Reset Maintenance 1, 2 or 3	Active when the relevant <i>Maintenance Alarm Reset</i> is active	
Scheduled Auto Start Inhibit	Active when the <i>Inhibit Scheduled Run</i> input is active	
SCR Inducement	Active when <i>SCR Inducement CAN Alarm</i> is active	
Screensaver Active	Active when the <i>Screensaver</i> is active on the module.	
Shutdown Blocked	Becomes active when protections are disabled and one of the parameters goes out of limits	

Output Source	Activates...	Is Not Active....
Simulate Auto Button	Active when the <i>Simulate Auto Button</i> digital input is active	
Simulate Close Gen Breaker	Active when the <i>Simulate Close Gen Breaker</i> digital input is active	
Simulate Lamp Test	Active when the <i>Simulate Lamp Test</i> input digital is active	
Simulate Mains Available	Active when the <i>Simulate Mains Available</i> digital input is active	
Simulate Manual Button	Active when the <i>Simulate Manual</i> digital input is active	
Simulate Open Gen Breaker	Active when the <i>Simulate Open Gen Breaker</i> digital input is active	
Simulate Start Button	Active when the <i>Simulate Start Button</i> digital input is active	
Simulate Stop Button	Active when the <i>Simulate Stop Button</i> digital input is active	
Simulate Test On Load Button	Active when the <i>Simulate Test On Load Button</i> digital input is active	
Smoke Limiting	Becomes active when the controller requests that the engine runs at idle speed. As an output, this is used to give a signal to the <i>Idle Speed Input</i> on the engine speed governor (if available)	Becomes inactive when the controller requests that the engine runs at rated speed.
SMS Remote Start Off Load	Active when the set receives an SMS message to start and run off load	
SMS Remote Start On Load	Active when the set receives an SMS message to start and run load	
Start Relay IEEE 37.2 – 54 Turning Gear Engaging Device	Active when the controller requires the cranking of the engine.	
Stop and Panel lock	Active when the <i>Stop And Panel Lock</i> digital input is active	
System in Auto Mode	Active when Auto mode is selected	
System in Manual Mode	Active when Manual mode is selected	
System in Stop Mode	Active when Stop mode is selected	
System in Test Mode	Active when Test On Load mode is selected	
Telemetry Active	Active when the communication port is live and for a short time after transmission stops. Used as a relay or LED source.	
Telemetry Data Active	Active when data is being transmitted. This output changes continuously state (flash) upon data transfer. Normally used as an LED source rather than a relay source as the signal flashes repeatedly. For a similar source more suited to drive a relay, see <i>Telemetry Active</i> .	
Temperature Sensor Open Circuit	Active when the <i>Temperature Sensor Open Circuit</i> alarm is active	
Under Frequency Shutdown \ Electrical Trip	Active when any of the <i>Generator Under Frequency Shutdown</i> or <i>Electrical Trip</i> alarm are active	
Under Frequency Warning	Active when the <i>Generator Under Frequency Warning</i> alarm is active	
Under Speed Shutdown \ Electrical trip	Active when any of the <i>Under Speed Shutdown</i> or <i>Electrical Trip</i> alarms are active	
Under Speed Warning	Active when the <i>Under Speed Warning</i> alarm is active.	
Waiting For Manual Restore 	Becomes active when the generator is on load and the mains supply is healthy but an input configured to Manual Restore is active. This is used to signal to an operator that action is required before the set transfers back to the mains supply.	
Water in Fuel	Active when the <i>Water in Fuel</i> input is active, or when the module is informed of the <i>Water in Fuel</i> CAN message from the ECU.	

2.6 TIMERS

Many timers are associated with alarms. Where this occurs, the timer for the alarm is located on the same page as the alarm setting. Timers not associated with an alarm are located on the timers page. The *Timers* page is subdivided into smaller sections. Select the required section with the mouse.

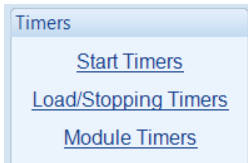

2.6.1 START TIMERS

Start Delay

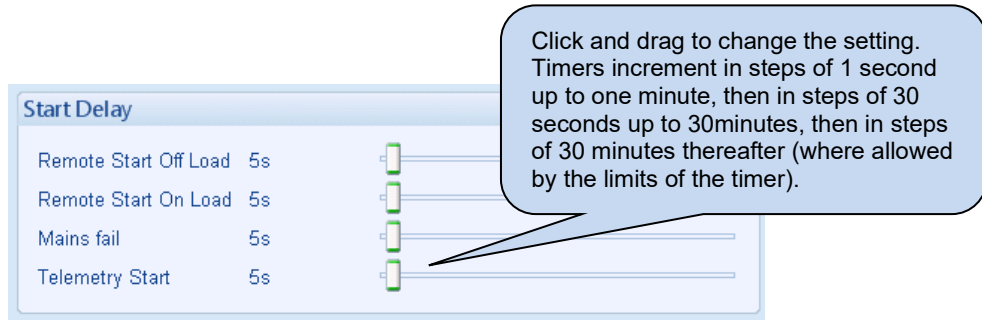



= Only available on DSE7320 MKII AMF Modules



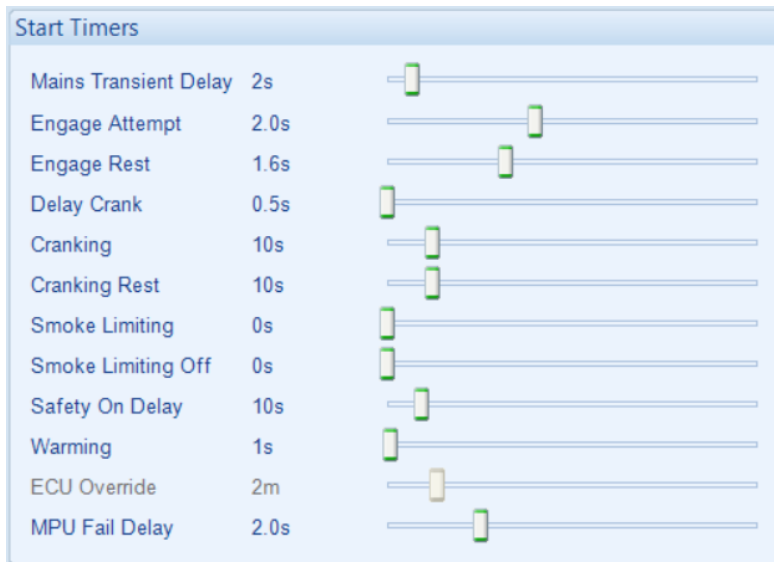

Timer	Description
Remote Start Off Load	The amount of time delay before starting in AUTO mode. This timer is activated upon the <i>Remote Start Off Load</i> command being issued. Typically this timer is applied to prevent starting upon fleeting start signals.
Remote Start On Load	The amount of time delay before starting in AUTO mode. This timer is activated upon the <i>Remote Start On Load</i> command being issued. Typically this timer is applied to prevent starting upon fleeting start signals.
Mains Fail 	The amount of time delay before starting in AUTO mode. This timer is activated upon a mains failure detection.
Telemetry Start	The amount of time delay before starting in AUTO mode. This timer is activated upon a <i>Remote Start</i> command being received from a MODBUS client. Typically this timer is applied to prevent starting upon fleeting start signals.

Parameter descriptions are continued overleaf...

Start Timers



= Only available on DSE7320 MKII AMF Modules

Timer	Description
 Mains Transient Delay	Used to give a delay between sensing mains failure and acting upon it. This is used to prevent dropouts of the mains load switch and operation of the system due to mains supply transient conditions.
Engage Attempt	<p> NOTE: Only available if using magnetic pick-up and multiple engage attempts</p> <p>The amount of time the module attempts to engage the starter motor during each engage attempt. If the Magnetic Pick-up is not detecting movement of the flywheel when this timer expires, the engage attempt terminates. When the engage fails consecutively for the configured number of <i>Engage Attempts</i>, the <i>Fail to Engage</i> alarm is activated.</p>
Engage Rest	<p> NOTE: Only available if using magnetic pick-up and multiple engage attempts</p> <p>The amount of time the module waits between attempts to engage the starter.</p>
Delay Crank	The amount of time delay between the fuel relay and the crank relay energising. This is typically used to allow fuel systems to prime.
Cranking	The amount of time for each crank attempt
Crank Rest	The amount of time between multiple crank attempts.
Smoke Limit	The amount of time that the engine is requested to run at idle speed upon starting. This is typically used to limit emissions at startup.
Smoke Limit Off	The amount of time that the engine takes to run up to rated speed after removal of the command to run at idle speed. If this time is too short, the engine is stopped due to an <i>Under Speed</i> alarm. If the time is too long, <i>Under Speed</i> protection is disabled until the <i>Smoke Limit Time Off</i> time has expired.
Safety On Delay	The amount of time at startup that the controller ignores oil pressure and engine speed and other delayed alarms. This is used to allow the engine to run up to speed before protections are activated.
Warming	The amount of time the engine runs before being allowed to take load. This is used to warm the engine to prevent excessive wear.
ECU (ECM) Override	The amount of time the CAN ECU Power stays energised when the Start button is pressed in Stop mode.
MPU Fail Delay	<p> NOTE: Only available if using Magnetic pick-up</p> <p>The amount of time during which the module must receive a speed signal once cranking has commenced. If no signal is present, the engine is stopped, and a <i>Loss of Magnetic Pickup</i> alarm given.</p>

2.6.2 LOAD / STOPPING TIMERS

Load Timers



= Only available on DSE7320 MKII AMF Modules

Timer	Description
 Transfer Time The time between one load switch opening and the other closing. Used during transfer to and from the generator.	
Breaker Close Pulse	The amount of time that <i>Breaker Close Pulse</i> signal is present when the request to close the load switch is given.
Breaker Trip Pulse	The amount of time that <i>Breaker Open Pulse</i> signal is present when the request to open the load switch is given.

Stopping Timers

Click and drag to change the setting.
Timers increment in steps of 1second up to one minute, then in steps of 30seconds up to 30minutes, then in steps of 30minutes thereafter (where allowed by the limits of the timer).

Timer	Description
Return Delay	A delay, used in auto mode only, that allows for short term removal of the request to stop the set before action is taken. This is usually used to ensure the set remains on load before accepting that the start request has been removed.
Cooling	The amount of time that the set is made to run OFF LOAD before being stopped. This is to allow the set to cool down and is particularly important for engines with turbo chargers.
Cooling At Idle	The amount of time that the set is made to run OFF LOAD and at Idle Speed before being stopped.
ETS Solenoid Hold	The amount of time the <i>Energise to stop</i> solenoid is kept energised after the engine has come to rest. This is used to ensure the set has fully stopped before removal of the stop solenoid control signal.
Fail To Stop Delay	If the set is called to stop and is still running after the <i>fail to stop</i> delay, a <i>Fail to Stop</i> alarm is generated.

2.6.3 MODULE TIMERS

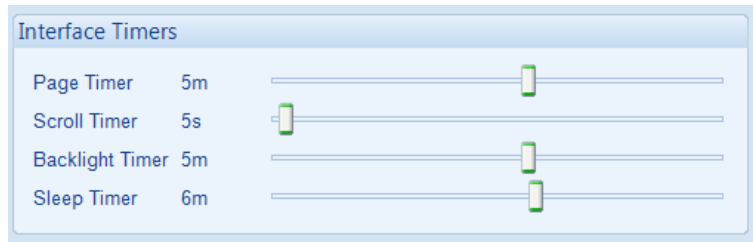

Timer	Description
LCD Page timer	If the module is left unattended for the duration of the <i>LCD Page Timer</i> it reverts to show the <i>Status</i> page.
LCD Scroll Timer	The scroll time between parameters on a selected page.
Backlight Timer	If the module is left unattended for the duration of the <i>Backlight Timer</i> , the LCD backlight turns off.
Sleep Timer	<p>NOTE: The Sleep Mode is disabled when the DSE25xx MKII remote display module is connected.</p>
	If the module is left unattended for the duration of the <i>Sleep Timer</i> , it goes into sleep mode to save power.

2.7 GENERATOR

The *Generator* section is subdivided into smaller sections. Select the required section with the mouse.

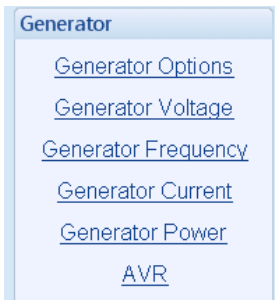

2.7.1 GENERATOR OPTIONS

Parameter	Description
Alternator Fitted	<input type="checkbox"/> = There is no alternator in the system, it is an <i>engine only</i> application. <input checked="" type="checkbox"/> = An alternator is fitted to the engine, it is a <i>generator</i> application.
Poles	The number of poles on the alternator.
VT Fitted	<input type="checkbox"/> = The voltage sensing to the controller is direct from the alternator <input checked="" type="checkbox"/> = The voltage sensing to the controller is via Voltage Transformers (VTs or PTs) This is used to step down the generated voltage to be within the controller voltage specifications. By entering the <i>Primary</i> and <i>Secondary</i> voltages of the transformer, the controller displays the <i>Primary</i> voltage rather than the actual measured voltage. This is typically used to interface the DSE module to high voltage systems (i.e. 11kV) but also used on systems such as 600V ph-ph.

2.7.1.1 BREAKER CONTROL

Parameter	Description
Enable Breaker Alarms	<p><input type="checkbox"/> = Alarm is disabled. <input checked="" type="checkbox"/> = The <i>Generator Fail To Close Alarm</i> and the <i>Generator Fail To Open Alarm</i> are enabled.</p> <p>During the generator closure process, when the <i>Close Generator</i> output is activated, if the configured <i>Generator Closed Auxiliary</i> digital input does not become active within the <i>Generator Fail To Close Delay</i> timer, the <i>Generator Fail to Close</i> alarm is activated.</p> <p>Or, during the generator opening process, when the <i>Close Generator</i> output is deactivated, if the configured <i>Generator Closed Auxiliary</i> digital input does not become inactive within the <i>Generator Fail To Open Delay</i> timer, the <i>Generator Fail To Open</i> alarm is activated.</p>
Paralleling Time 	<p>This is only applicable if the <i>Check Sync Closed Transition</i> is used.</p> <p>It is the time for the Generator Breaker remain closed with the Mains during the transfer from the generator to the mains.</p>

2.7.1.2 GENERATOR PHASE ROTATION

Parameter	Description
Generator Phase Rotation IEEE 37.2 – 47 Phase Sequence Relay	<p><input type="checkbox"/> = Generator phase rotation is not checked. <input checked="" type="checkbox"/> = An electrical trip alarm is generated when the measured phase rotation is not as configured.</p>

2.7.1.3 GENERATOR KW RATING

The screenshot shows a configuration window titled "Generator Rating". It contains three rows of settings:

- kW Rating:** A dropdown menu is set to "200". To its right is a slider control labeled "kW" with a value of "250kVA".
- kVAr Rating:** A dropdown menu is set to "150". To its right is a slider control labeled "kVAr" with a value of "0.80pf".
- Power factor:** A dropdown menu is set to "0.80". To its right is a slider control labeled "pf".

The Generator kW rating must be set in order for the *Generator Power* functions to be correctly utilised.
 The Generator kW and kVAr rating must be correctly set.
 The values you set here are the kW, kVAr, and Pf, NOT the kVA !

Calculating the VAr rating of a genset

- Most generators are rated for a power factor (W / VA) of 0.8
- From Pythagoras :
 - $\text{Cos } \phi = W / VA$
 - $\text{Cos } \phi = 0.8$
 - $\phi = \text{Cos}^{-1} 0.8 = 36.87^\circ$
- From this we calculate the VAr rating of the typical 0.8 pf rated generator as :
 - $\text{Tan } \phi = \text{VAr} / W$
 - $\text{VAr} = \text{Tan } 36.87 \times W$
 - $\text{VAr} = 0.75 \times W$
- Or to simplify this, the VAr rating of a 0.8 pf rated generator is $\frac{3}{4}$ of the W rating (kVAr rating = 75% of kW rating)

2.7.2 GENERATOR VOLTAGE

The screenshot shows the 'Generator Voltage' configuration page, divided into four sections: Under Voltage Alarms, Loading Voltage, Nominal Voltage, and Over Voltage Alarms. Each section contains adjustable parameters like trip values, activation delays, and alarm actions. Callouts provide instructions: 'Select the type of alarm required. For details of these, see the section entitled *Alarm Types* elsewhere in this document.' (pointing to the 'Shutdown' dropdown), 'Click and drag to change the setting.' (pointing to a slider), and 'Type the value or click the up and down arrows to change the settings' (pointing to a numeric input field).

2.7.2.1 UNDER VOLTAGE ALARMS

Parameter	Description
Generator Under Voltage Alarm IEEE 37.2 - 27AC Undervoltage Relay	<input type="checkbox"/> = Generator Under Volts does NOT give an alarm. <input checked="" type="checkbox"/> = Generator Under Volts gives an alarm in the event of the generator output falling below the configured <i>Under Volts Alarm Trip</i> value for longer than the <i>Activation Delay</i> . The <i>Under Voltage Alarm Trip</i> value is adjustable to suit user requirements.
Action	Select the type of alarm required from the list: Shutdown. Electrical Trip. For details of these, see the section entitled <i>Alarm Types</i> elsewhere in this document.
Generator Under Voltage Pre-Alarm IEEE 37.2 - 27AC Undervoltage Relay	<input type="checkbox"/> = Generator Under Volts does NOT give a warning alarm. <input checked="" type="checkbox"/> = Generator Under Volts gives a warning alarm in the event of the generator output falling below the configured <i>Under Volts Pre-Alarm Trip</i> value for longer than the <i>Activation Delay</i> . The <i>Under Voltage Pre-Alarm Trip</i> value is adjustable to suit user requirements.

2.7.2.2 LOADING VOLTAGE

Parameter	Description
Loading Voltage	This is the minimum voltage the generator must be operating at before the module considers it available to take the load. It is also the voltage above the under voltage trip that the generator output must return to before the module considers that the supply is back within limits. (i.e. With an under voltage trip of 184.0V and a loading voltage of 207.0V, the output voltage must return to 207.0V following an under voltage event to be considered within limits.)
Enable Alarm	<input type="checkbox"/> = Alarm is disabled. <input checked="" type="checkbox"/> = Upon starting and after the <i>Safety On Delay Timer</i> expires, if the generator output voltage fails to reach the <i>Loading Voltage</i> setpoint, the <i>Loading Voltage Not Reached</i> alarm is activated.

2.7.2.3 NOMINAL VOLTAGE

Parameter	Description
Nominal Voltage	This is used to calculate the percentages of the alarm setpoints.

2.7.2.4 OVER VOLTAGE ALARMS

Parameter	Description
Generator Over Voltage Pre-Alarm IEEE 37.2 – 59 AC Overvoltage Relay	<input type="checkbox"/> = Alarm is disabled. <input checked="" type="checkbox"/> = Generator Over Volts gives a warning alarm in the event of the generator output voltage rising above the configured <i>Over Volts Pre-Alarm Trip</i> value for longer than the <i>Activation Delay</i> . The <i>Warning</i> is automatically reset when the generator output voltage falls below the configured <i>Return</i> level. The <i>Over Volts Pre-Alarm Trip</i> value is adjustable to suit user requirements.
Generator Over Voltage IEEE 37.2 – 59 AC Overvoltage Relay	<input type="checkbox"/> = Alarm is disabled. <input checked="" type="checkbox"/> = Generator Over Volts gives a <i>Shutdown</i> alarm in the event of the generator output rising above the configured <i>Over Volts Alarm Trip</i> value for longer than the <i>Activation Delay</i> . The <i>Overvolts Alarm Trip</i> value is adjustable to suit user requirements.

2.7.3 GENERATOR FREQUENCY

The screenshot displays the 'Generator Frequency' configuration page, organized into several sections:

- Under Frequency Alarms:** Includes an 'Alarm' checkbox (checked), an 'Action' dropdown set to 'Shutdown', a 'Trip' slider at 40.0 Hz (80.0%), a 'Pre-alarm' checkbox (checked), a 'Pre-alarm Trip' slider at 42.0 Hz (84.0%), and an 'Activation Delay' slider at 0s.
- Loading Frequency:** Includes a 'Loading Frequency' slider at 45.0 Hz (90.0%) and an 'Alarm' checkbox (unchecked) with an 'Action' dropdown set to 'Warning'.
- Nominal Frequency:** Includes a 'Nominal Frequency' slider at 50.0 Hz (100%).
- Over Frequency Alarms:** Includes a 'Pre-alarm' checkbox (checked), 'Return' and 'Trip' sliders at 54.0 Hz (108.0%) and 55.0 Hz (110.0%) respectively, a 'Shutdown' checkbox (checked), a 'Trip' slider at 57.0 Hz (114.0%), and an 'Activation Delay' slider at 0s.
- Run Away:** Includes a 'Run Away' checkbox (checked) and a 'Trip' slider at 60.0 Hz (120.0%).
- Over Frequency Options:** Includes 'Over Frequency Overshoot %' set to 0 and 'Overshoot Delay' set to 2.0s.

Callouts provide the following instructions:

- Under Frequency Alarms:** "Click and drag to change the setting." (pointing to the 40.0 Hz slider).
- Nominal Frequency:** "Click to enable or disable the alarms. The relevant values below appear *greyed out* if the alarm is disabled." (pointing to the 'Alarm' checkbox in the Loading Frequency section).
- Over Frequency Alarms:** "Click to enable or disable the alarms. The relevant values below appear *greyed out* if the alarm is disabled." (pointing to the 'Pre-alarm' checkbox).
- Run Away:** "Type the value or click the up and down arrows to change the settings" (pointing to the 60.0 Hz slider).

Parameters are detailed overleaf...

2.7.3.1 UNDER FREQUENCY ALARMS

Parameter	Description
Generator Under Frequency Alarm IEEE 37.2 -81 Frequency Relay	<input type="checkbox"/> = Generator Under Frequency does NOT give an alarm <input checked="" type="checkbox"/> = Generator Under Frequency gives an alarm in the event of the generator output frequency falling below the configured <i>Under Frequency Alarm Trip</i> value for longer than the <i>Activation Delay</i> . The <i>Underfrequency Alarm Trip</i> value is adjustable to suit user requirements.
Action	Select the type of alarm required from the list: <i>Shutdown</i> . <i>Electrical Trip</i> . For details of these, see the section entitled <i>Alarm Types</i> elsewhere in this document.
Generator Under Frequency Pre-Alarm IEEE 37.2 -81 Frequency Relay	<input type="checkbox"/> = Generator Under Frequency does NOT give a warning alarm. <input checked="" type="checkbox"/> = Generator Under Frequency gives a warning alarm in the event of the generator output frequency falling below the configured <i>Under Frequency Pre-Alarm Trip</i> value for longer than the <i>Activation Delay</i> . The <i>Under Frequency Pre-Alarm Trip</i> value is adjustable to suit user requirements.

2.7.3.2 LOADING FREQUENCY

Parameter	Description
Loading Frequency	This is the minimum frequency the generator must be operating at, before the module considers it available to take the load. It is also the frequency above the under frequency trip that the generator output must return to before the module considers that the supply is back within limits. (i.e. With an underfrequency trip of 42.0 Hz and a loading frequency of 45.0 Hz, the output frequency must return to 45.0 Hz following an under frequency event to be considered within limits.)
Enable Alarm	<input type="checkbox"/> = Alarm is disabled. <input checked="" type="checkbox"/> = Upon starting and after the <i>Safety On Delay Timer</i> expires, if the generator output frequency fails to reach the <i>Loading Frequency</i> setpoint, the <i>Loading frequency Not Reached</i> alarm is activated.

2.7.3.3 NOMINAL FREQUENCY

Parameter	Description
Nominal Frequency	This is used to calculate the percentages of the alarm setpoints.

2.7.3.4 OVER FREQUENCY ALARMS

Parameter	Description
Generator Over Frequency Pre-Alarm IEEE 37.2 -81 Frequency Relay	<input type="checkbox"/> = Alarm is disabled. <input checked="" type="checkbox"/> = Generator Over Frequency gives a warning alarm in the event of the generator output frequency rising above the configured <i>Over frequency Pre-Alarm Trip</i> value for longer than the <i>Activation Delay</i> . The <i>Warning</i> is automatically reset when the generator output frequency falls below the configured <i>Return</i> level. The <i>Over Frequency Pre-Alarm Trip</i> value is adjustable to suit user requirements.
Generator Over Frequency IEEE 37.2 -81 Frequency Relay	<input type="checkbox"/> = Alarm is disabled. <input checked="" type="checkbox"/> = Generator Over Frequency gives a <i>Shutdown</i> alarm in the event of the generator output rising above the configured <i>Over Frequency Alarm Trip</i> value for longer than the <i>Activation Delay</i> . The <i>Over Frequency Alarm Trip</i> value is adjustable to suit user requirements.

2.7.3.5 RUN AWAY

Parameter	Description
Run Away IEEE 37.2 -81 Frequency Relay	<p> NOTE: Only available if using magnetic pick-up or an electronic engine is connected.</p> <p><input type="checkbox"/> = Alarm is disabled. <input checked="" type="checkbox"/> = In the event of the generator output frequency rising above the configured <i>Trip</i> value, the <i>Run Away Shutdown</i> alarm is immediately triggered. This is used to protect against engine damage due to uncontrolled speed increase, where the engine speed runs away.</p>
Trip	Set the frequency level for the <i>Run Away</i> alarm.

2.7.3.6 OVER FREQUENCY OPTIONS

Parameter	Description
Over Frequency Overshoot % IEEE 37.2 -81 Frequency Relay	To prevent spurious over-frequency alarms at start up, the module includes configurable <i>Over Frequency Overshoot</i> protection. This allows the frequency to 'overshoot' the <i>Over-Frequency Shutdown</i> level during the starting process for a short time.
Overshoot Delay	Rather than 'inhibiting' the <i>Over Frequency</i> alarms, the levels are temporarily raised by the <i>Over Frequency Overshoot %</i> for the duration of the <i>Overshoot Delay</i> from starting.

2.7.4 GENERATOR CURRENT

The *generator* section is subdivided into smaller sections. Select the required section with the mouse.



2.7.4.1 GENERATOR CURRENT OPTIONS

NOTE: It is not possible to write the configuration to the module if the *CT Location* is set to *Load* and the *AC System* in the *Generator Options* and in the *Mains Options* are not the same.

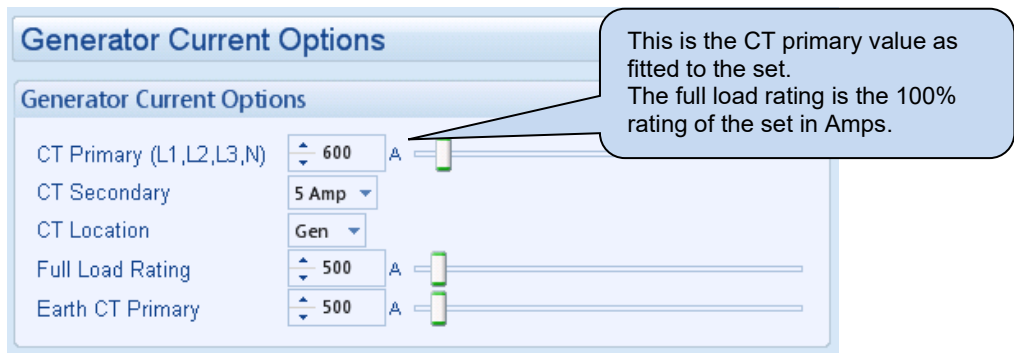

Parameter	Description
CT Primary	Primary rating of the three phase Current Transformers.
CT Secondary	Secondary rating of the Current Transformers.
CT Location	<div style="border: 1px solid black; padding: 5px; margin-bottom: 5px;"> <p>NOTE: When the <i>CT Location</i> is set to <i>Load</i>, the <i>AC System</i> in the <i>Generator Options</i> and in the <i>Mains Options</i> must be the same.</p> </div> <p>Gen: The CTs are in the feed from the generator, the module shows only generator load.</p> <p>Load: The CTs are in the feed to the load, the module then displays load current, provided by the mains supply or the generator.</p>
Full Load Rating	This is the full load current rating of the alternator.
Earth CT Primary	Primary rating of the earth fault Current Transformers.

2.7.4.2 GENERATOR CURRENT ALARMS

Generator Current Alarms

Overcurrent Alarm

Immediate Warning
 IDMT Alarm
 Trip: % 500 A
 Time Multiplier:
 Action: Electrical Trip

Short Circuit

Enabled
 Action: Electrical Trip
 Trip: % 1000 A
 Time Multiplier:

Negative Phase Sequence

Enable
 Action: Shutdown
 Trip Level: %
 Delay: s

Earth Fault

Enable
 Action: Shutdown
 Trip Level: % 50.0 A
 Time Multiplier:

2.7.4.3 OVERCURRENT ALARM

The overcurrent alarm combines a simple warning trip level combined with a fully functioning IDMT curve for thermal protection.

2.7.4.3.1 IMMEDIATE WARNING

IEEE 37.2 -50 instantaneous overcurrent relay

If the *Immediate Warning* is enabled, the controller generates a *warning alarm* as soon as the *Trip* level is reached. The alarm automatically resets once the generator loading current falls below the *Trip* level (unless *All Warnings are latched* is enabled). For further advice, consult the generator supplier.

2.7.4.3.2 IDMT ALARM

IEEE 37.2 -51 AC time overcurrent relay (shutdown / electrical trip)

If the *Over Current IDMT Alarm* is enabled, the controller begins following the IDMT 'curve' when the current on any phase passes the *Trip* setting.

If the *Trip* is surpassed for an excess amount of time, the *IDMT Alarm* triggers (*Shutdown* or *Electrical Trip* as selected in *Action*).

The larger the over circuit fault, the faster the trip. The speed of the trip is dependent upon the fixed formula:

$$T = \frac{t}{\left(\frac{I_A}{I_T} - 1\right)^2}$$

Where:

T is the tripping time in seconds.

I_A is the actual measured current of the most highly loaded line (L1, L2 or L3).

I_T is the delayed trip point setting in current.

t is the time multiplier setting and also represents the tripping time in seconds at twice full load (when $I_A/I_T = 2$).

The settings shown in the example below are a screen capture of the DSE factory settings, taken from the DSE Configuration Suite PC Software for a brushless alternator.

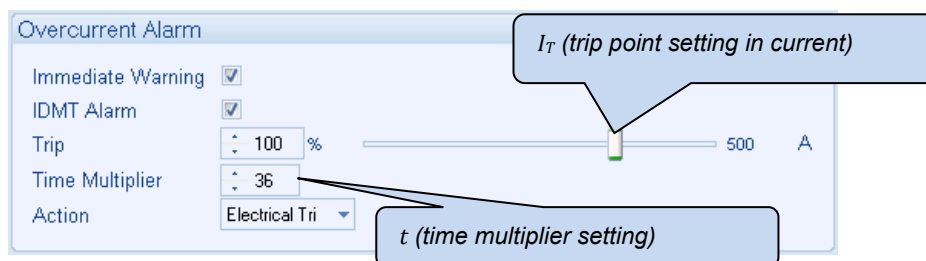

These settings provide for normal running of the generator up to 100% full load. If full load is surpassed, the *Immediate Warning* alarm is triggered and the set continues to run.

The effect of an overload on the generator is that the alternator windings begin to overheat; the aim of the *IDMT Alarm* is to prevent the windings being overload (heated) too much. The amount of time that the alternator is safely overloaded is governed by how high the overload condition is.

The default settings as shown above allow for an overload of the alternator to the limits of the *Typical Brushless Alternator* whereby 110% overload is permitted for 1 hour or 200% overload is permitted for 36 seconds.

If the alternator load reduces, the controller then *follows* a cooling curve. This means that a second overload condition may trip soon after the first as the controller *knows* if the windings have not cooled sufficiently.

For further details on the *Thermal Damage Curve* of your alternator, refer to the alternator manufacturer and generator supplier.

2.7.4.3.3 CREATING A SPREADSHEET FOR THE OVER CURRENT IDMT CURVE

The formula used:

$$T = \frac{t}{\left(\frac{I_A}{I_T} - 1\right)^2}$$

Where:

- T is the tripping time in seconds.
- I_A is the actual measured current of the most highly loaded line (L1, L2 or L3).
- I_T is the delayed trip point setting in current.
- t is the time multiplier setting and also represents the tripping time in seconds at twice full load (when $I_A/I_T = 2$).

The equation is simplified for addition into a spreadsheet. This is useful for 'trying out' different values of t (*time multiplier setting*) and viewing the results, without actually testing this on the generator.

	A	B	C	D	E	F
1		1.01	1.02	1.03	1.05	1.06
2	36	360000	90000	40000	14400	10000

t (*time multiplier setting*)

T (*tripping time in seconds*)

I_A/I_T (*multiple of the Trip setting from 1.01 to 3.0 in steps of 0.1*)

The formula for the *Tripping Time* cells is:

```
fx = $A2/POWER((B$1-1),2)
```

Over Current Alarm IDMT Curves

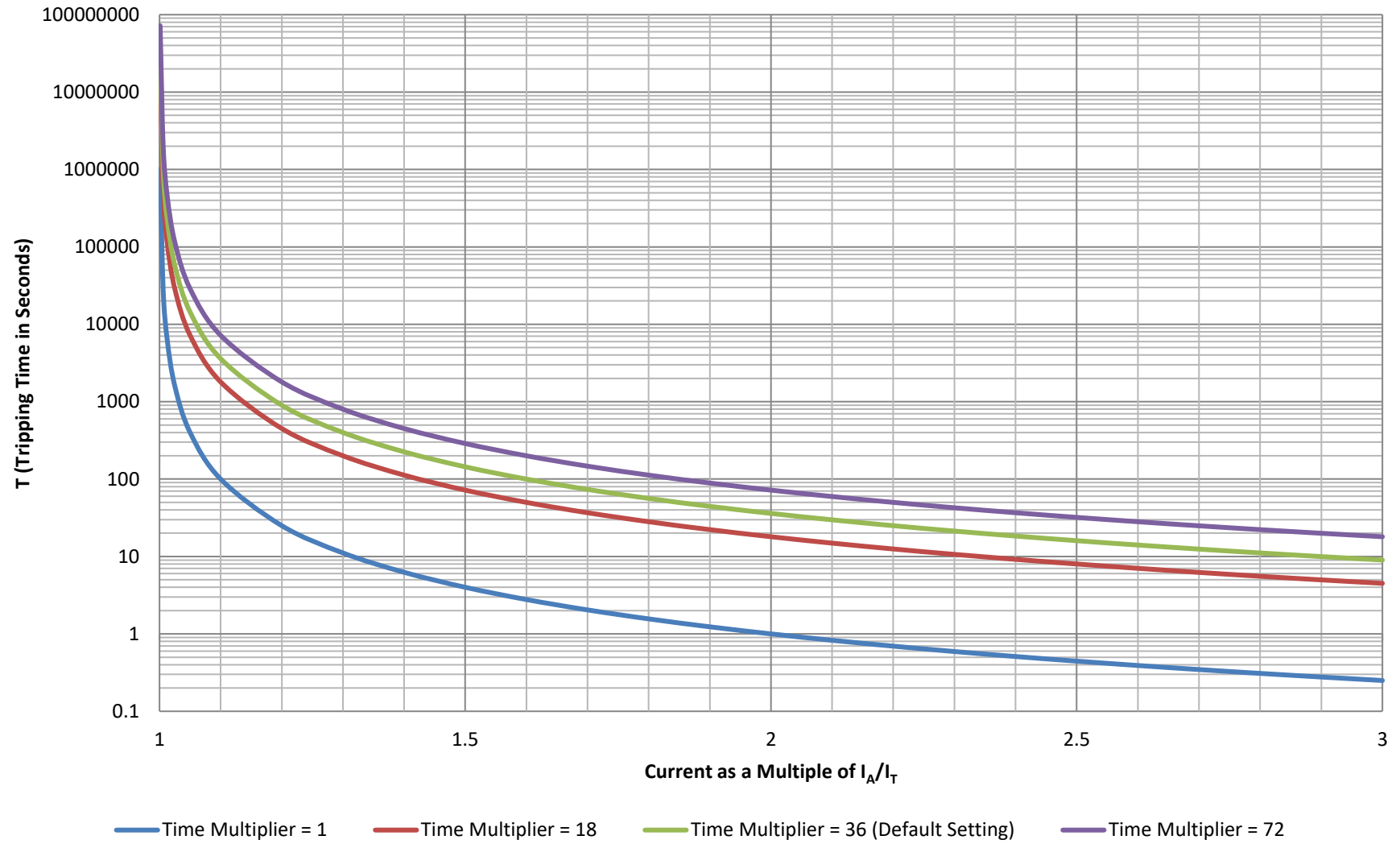

2.7.4.4 SHORT CIRCUIT ALARM

IEEE C37.2 – 51 IDMT Short Circuit Relay

If the *Short Circuit Alarm* is enabled, the controller begins following the IDMT ‘curve’ when the current on any phase passes the *Trip* setting.

If the *Trip* is surpassed for an excess amount of time, the *IDMT Alarm* triggers (*Shutdown* or *Electrical trip* as selected in *Action*).

The larger the short circuit fault, the faster the trip. The speed of the trip is dependent upon the fixed formula:

$$T = \frac{t \times 0.14}{\left(\left(\frac{I_A}{I_T}\right)^{0.02} - 1\right)}$$

Where:

- T is the tripping time in seconds (accurate to +/- 5% or +/- 50 ms (whichever is the greater)).
- I_A is the actual measured current.
- I_T is the trip point setting in current.
- t is the time multiplier setting.

The settings shown in the example below are a screen capture of the DSE factory settings, taken from the DSE Configuration Suite software.

NOTE: Due to large inrush currents from certain loads, such as motors or transformers, the default settings for the Short Circuit alarm may need adjusting to compensate.

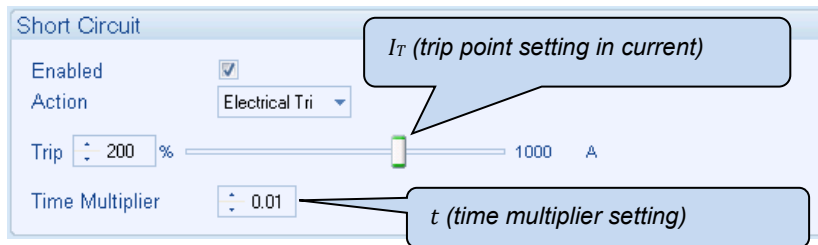

The effect of a short circuit on the generator is that the alternator stator and rotor begin to overheat; the aim of the *IDMT alarm* is to prevent the stator and rotor being overload (heated) too much. The amount of time that the alternator is safely overloaded is governed by how high the short circuit condition is.

For further details on the *Thermal & Magnetic Damage Curve* of your alternator, refer to the alternator manufacturer and generator supplier.

2.7.4.4.1 CREATING A SPREADSHEET FOR THE SHORT CIRCUIT IDMT CURVE

The formula used:

$$T = \frac{t \times 0.14}{\left(\left(\frac{I_A}{I_T}\right)^{0.02} - 1\right)}$$

Where:

T is the tripping time in seconds (accurate to +/- 5% or +/- 50 ms (whichever is the greater)).

I_A is the actual measured current.

I_T is the trip point setting in current.

t is the time multiplier setting.

The equation is simplified for addition into a spreadsheet. This is useful for 'trying out' different values of t (*time multiplier setting*) and viewing the results, without actually testing this on the generator.

	A	B	C	D	E	F
1		1.01	1.02	1.03	1.05	1.06
2	0.01	7.034242	25	11.11111	4	2.777778

t (time multiplier setting)

T (tripping time in seconds)

I_A/I_T (multiple of the Trip setting from 1.01 to 3.0 in steps of 0.1)

The formula for the *Tripping Time* cells is:

`=($A2*0.14)/(POWER((B$1),0.02)-1)`

Short Circuit Alarm IDMT Curves

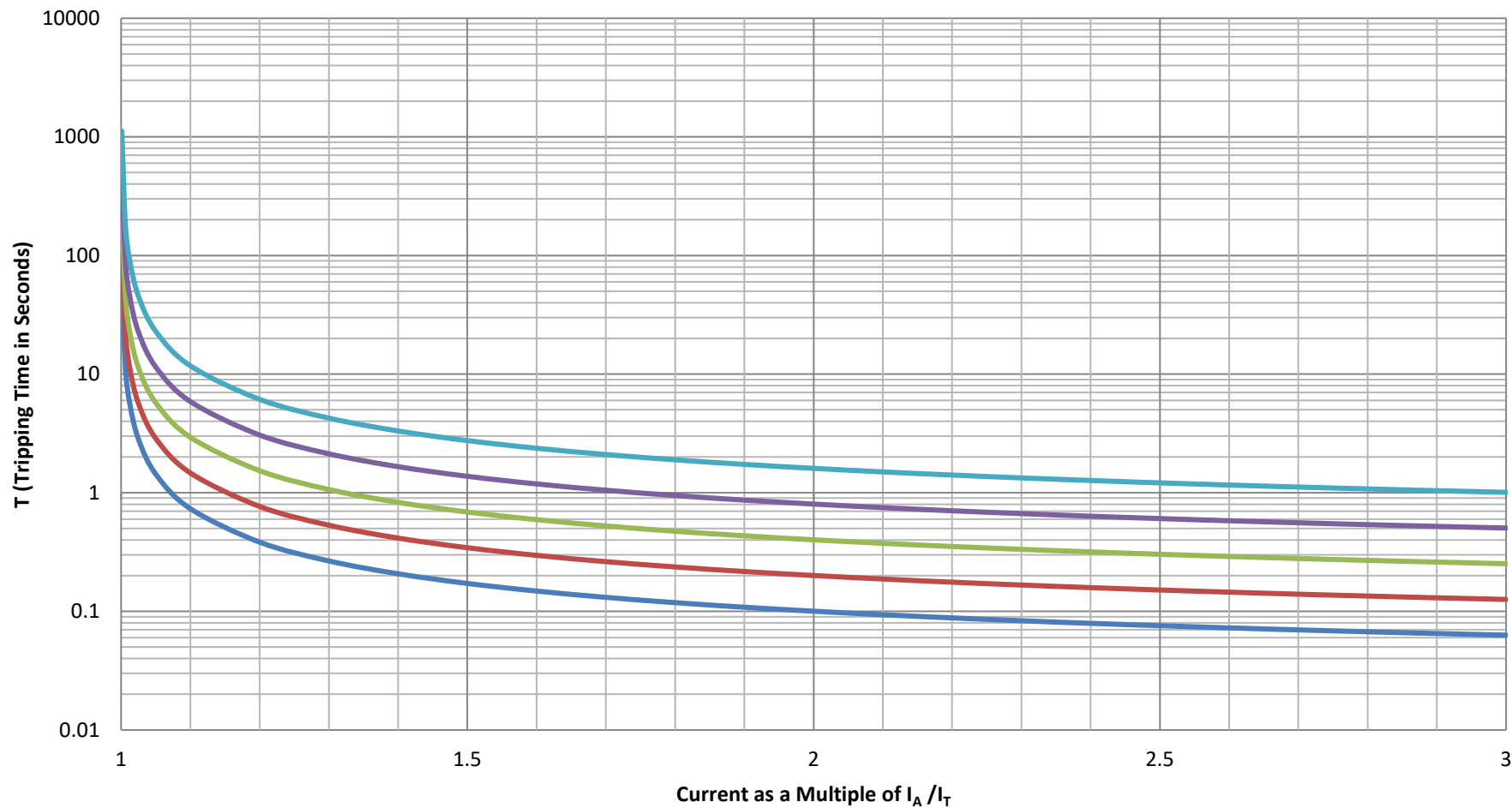

Time Multiplier = 0.01 (Default Setting) Time Multiplier = 0.02 Time Multiplier = 0.04
Time Multiplier = 0.08 Time Multiplier = 0.16

2.7.4.5 NEGATIVE PHASE SEQUENCE

IEEE C37.2 - 46 Phase-Balance Current Relay

Unbalanced loads cause negative sequence current in the alternator stator. These currents cause harmonics which eventually leads to overheating and melting of the rotor. An unbalanced load is, however, permissible within limits.

For recommended settings contact your alternator manufacturer.

2.7.4.6 EARTH FAULT ALARM

When the module is suitably connected using the 'Earth Fault CT'. The module measures Earth Fault and optionally configured to generate an alarm condition (shutdown or electrical trip) when a specified level is surpassed.

If the *Earth Fault Alarm* is enabled, the controller begins following the IDMT 'curve' when the earth fault current passes the *Trip* setting.

If the *Trip* is surpassed for an excess amount of time, the *IDMT Alarm* triggers (*Shutdown* or *Electrical Trip* as selected in *Action*).

The larger the earth fault, the faster the trip.

The settings shown in the example below are a screen capture of the DSE factory settings, taken from the DSE Configuration Suite software.

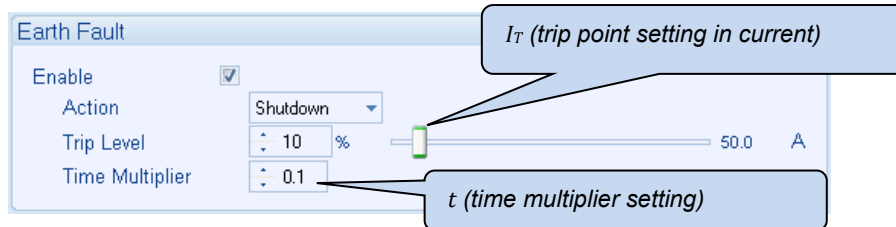

Earth Fault Alarm IDMT Curves

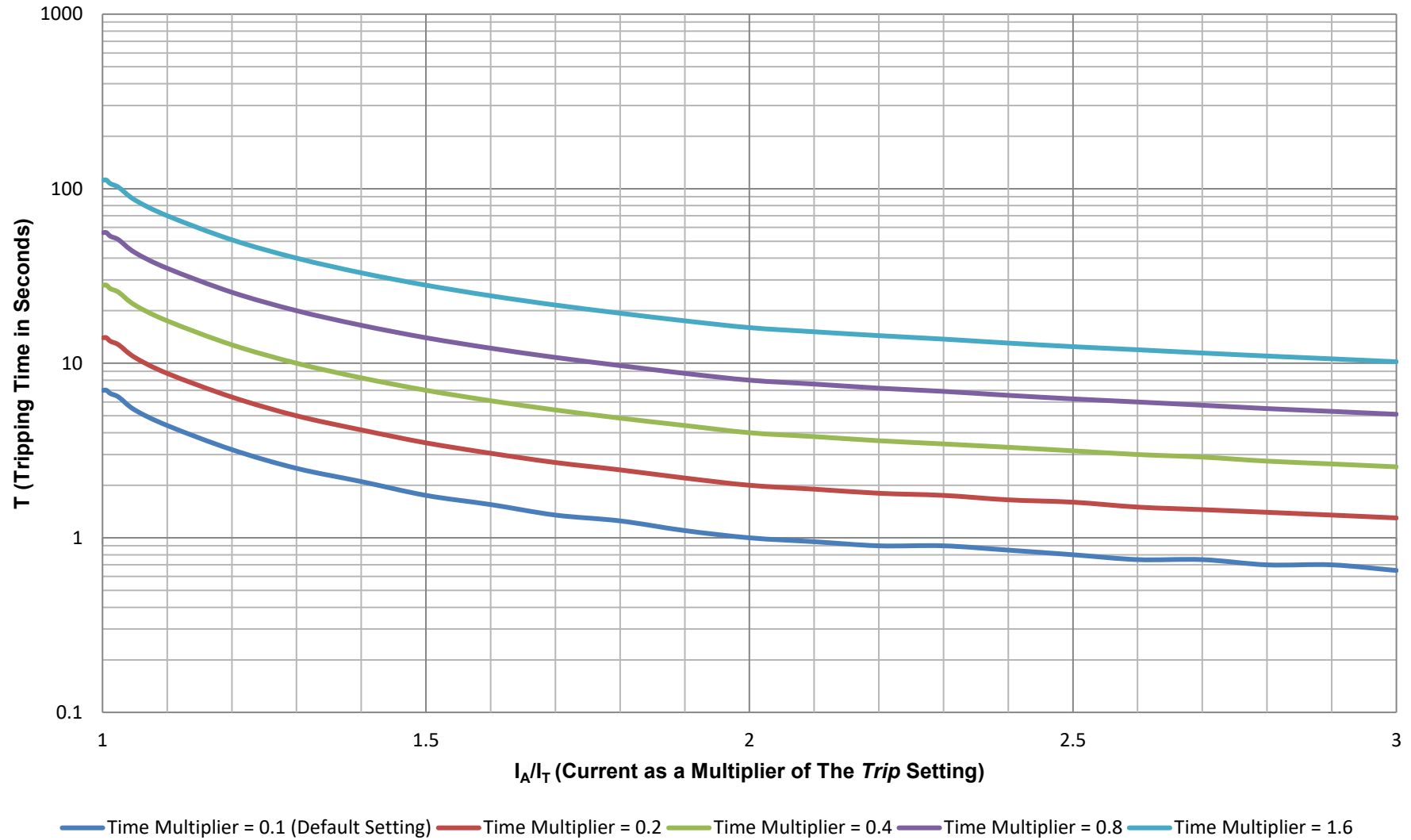

2.7.4.7 DEFAULT CURRENT PROTECTION TRIPPING CHARACTERISTICS

The graph on the following page shows the default settings for the IDMT tripping curves for the *Over Current*, *Short Circuit* and *Earth Fault* protections.

The default setting for the *Over Current* alarm allows for an overload of an alternator to the limits of the *Typical Brushless Alternator* whereby 110% overload is permitted for 1 hour or 200% overload is permitted for 36 seconds. In an over current situation the alternator begins to overheat. The aim of the *Over Current IDMT Alarm* is to prevent the windings being overload (heated) too much. The amount of time that the alternator is safely overloaded is governed by how high the overload condition is.

The default setting for the *Short Circuit* alarm allows for an alternator to supply a high current caused by an genuine short circuit or an in rush current of a motor/transformer. Whereby 300% overload is permitted for 0.17 seconds or 600% overload is permitted for 0.06 seconds. In a short circuit situation the alternator begins to overheat to the point the insulation breaks down, potentially causing a fire. The aim of the *Short Circuit IDMT Alarm* is to prevent the insulation from melting due to excessive heat. The amount of time that the alternator runs safely in a short circuit condition is governed by the alternator's construction.

DSE Default Configuration of Over Current, Short Circuit & Earth Fault Alarm IDMT Curves

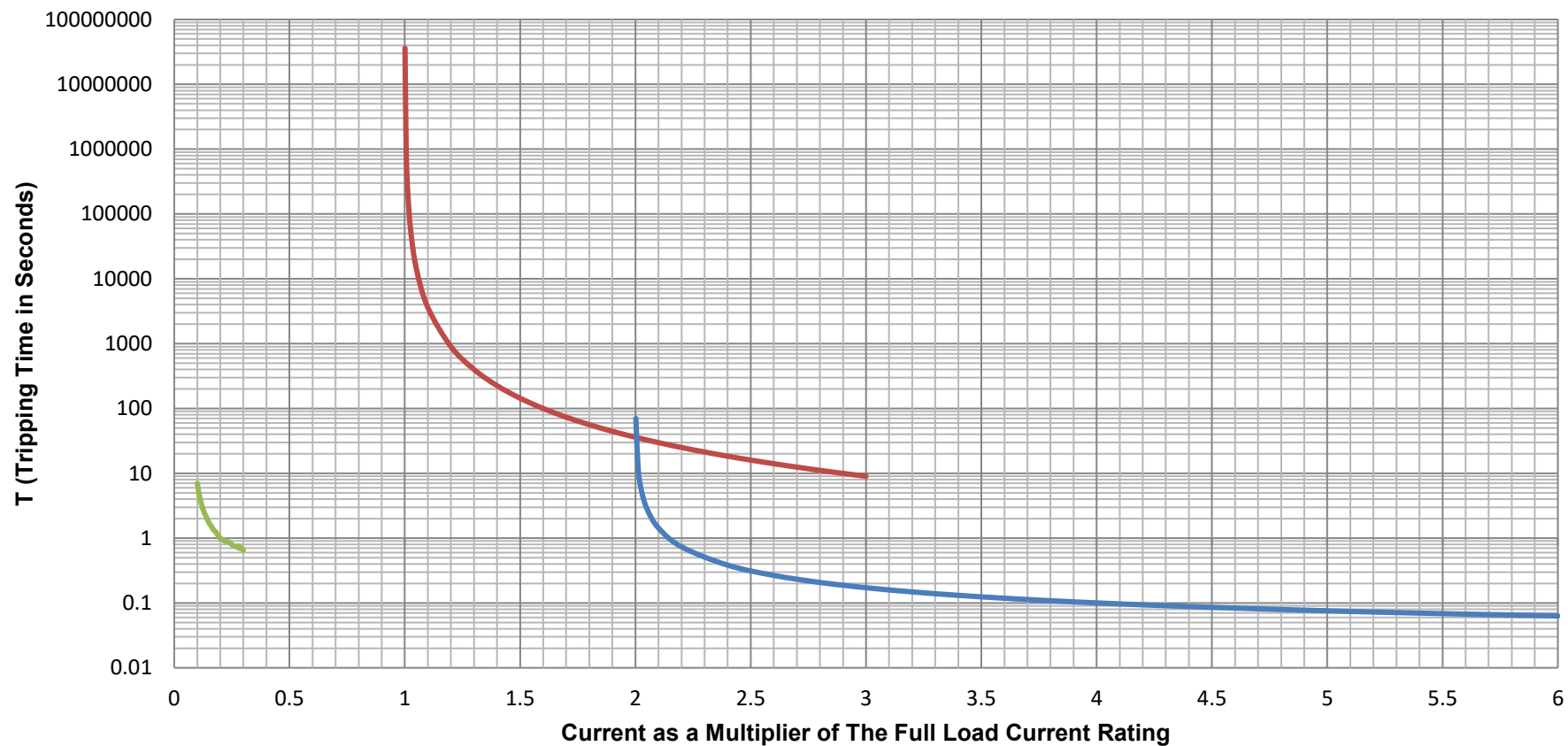

- Over Circuit IDMT Trip Curve with Time Multiplier = 36, Trip Point = 100% (Default Settings)
- Short Circuit IDMT Trip Curve with Time Multiplier = 0.01, Trip Point = 200% (Default Settings)
- Earth Fault IDMT Trip Curve with Time Multiplier = 0.1, Trip Point = 10% (Default Settings)

2.7.5 GENERATOR POWER

The *Generator Power* section is subdivided into smaller sections. Select the required section with the mouse.



2.7.5.1 OVERLOAD PROTECTION



Parameter	Description
Overload Protection	<input type="checkbox"/> = Overload Protection alarm is disabled. <input checked="" type="checkbox"/> = The <i>kW Overload Alarm</i> activates when the kW level exceeds the <i>Trip</i> setting for longer than the configured <i>Delay</i> time.
Action	Select the action for the <i>kW Overload Alarm</i> : Electrical Trip Indication Shutdown Warning

2.7.5.2 LOAD CONTROL

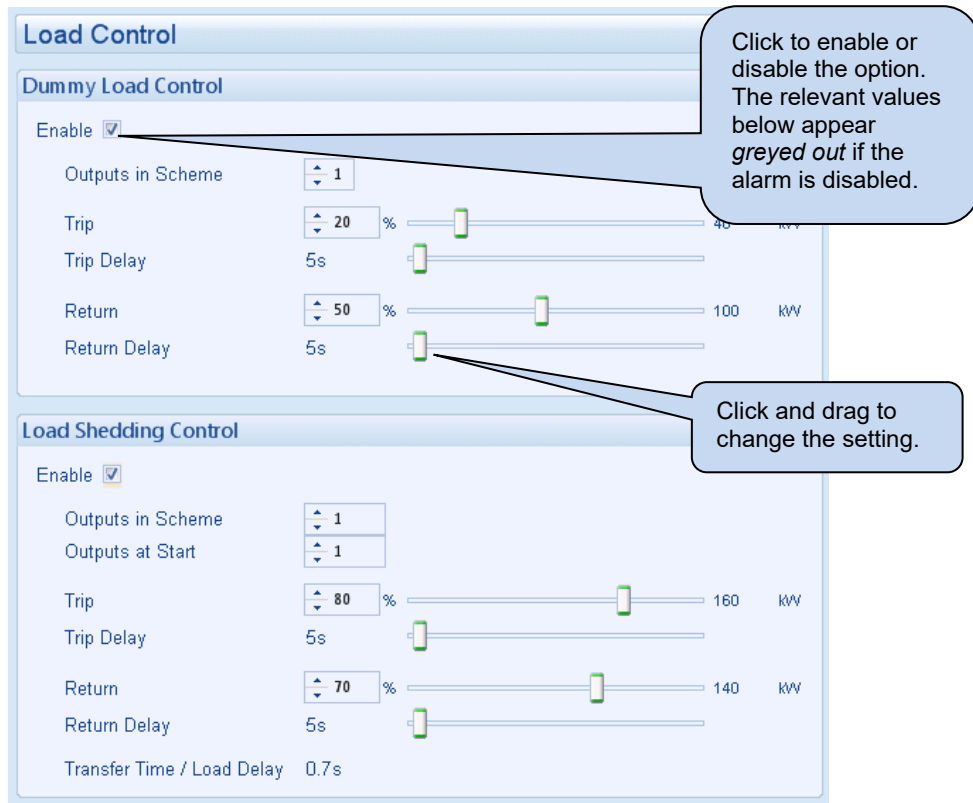

Parameter	Description
Dummy Load Control	Provides control of configurable outputs set to <i>Dummy Load Control</i> . <input type="checkbox"/> = Dummy Load Control is disabled. <input checked="" type="checkbox"/> = The module monitors the load and controls outputs configured to <i>Dummy Load Control (1-5)</i> .
Outputs in Scheme	The amount of Dummy Load Control outputs that are included in the function.
Trip / Trip Delay	When the load level is below the <i>Trip</i> setting for the duration of the <i>Trip Delay</i> , then the 'next' output configured to <i>Dummy Load Control</i> is activated (max 5).
Return / Return Delay	When the load level rises above the <i>Return</i> level for the duration of the <i>Return Delay</i> , then the 'highest numbered' output configured to <i>Dummy Load Control</i> is deactivated and the timer is reset.
Load Shedding Control	Provides control of configurable outputs set to <i>Load shedding control</i> . <input type="checkbox"/> = Load Shedding Control is disabled. <input checked="" type="checkbox"/> = The module monitors the load and controls any outputs configured to <i>Load Shedding Control (1-5)</i> .
Outputs in Scheme	The number of outputs (max 5) that is included in the function.
Outputs at Start	The number of outputs configured to <i>Load Shedding Control 1-5</i> that are energised when the set is required to take load. The <i>Transfer Delay / Load Delay</i> timer begins. At the end of this timer, the generator load switch is closed – The generator is placed on load.
Trip / Trip Delay	When the load level is above the <i>Trip</i> setting for the duration of the <i>Trip Delay</i> , then the 'next' output configured to <i>Load Shedding Control</i> is activated (max 5).
Return / Return Delay	When the load level is below the <i>Return</i> setting for the duration of the <i>Return Delay</i> , then the 'highest numbered' output configured to <i>Load Shedding Control</i> is deactivated and the timer is reset.
Transfer Time / Load Delay	The time between closing the <i>Load Shedding Control</i> outputs (<i>Outputs at Start</i>) and closing the generator load switching device.

2.7.5.3 REVERSE POWER

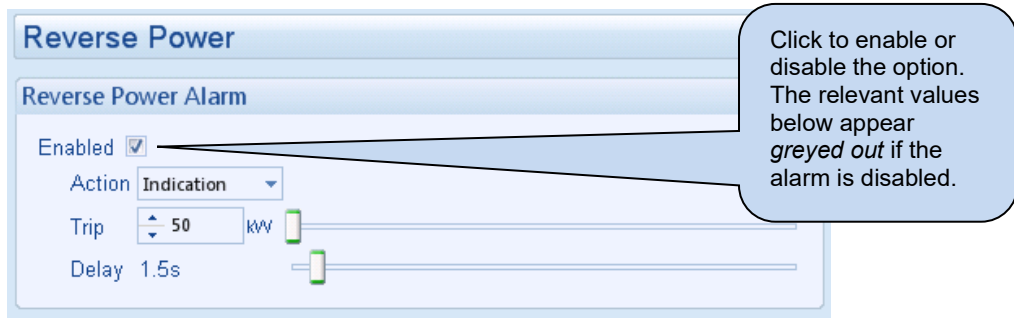

Parameter	Description
Reverse Power IEEE 37.2 – 32 Directional Power Relay	<input type="checkbox"/> = <i>Generator Reverse Power Alarm</i> is disabled. <input checked="" type="checkbox"/> = The <i>Generator Reverse Power Alarm</i> activates when the reverse power exceeds the <i>Reverse Power Trip</i> setting longer than the configured <i>Delay</i> time. This is used to protect against back feed from electric motors when mechanically overpowered.
Action	Select the action for the <i>Reverse Power Alarm</i> : Electrical Trip Indication Shutdown Warning

2.7.5.4 LOW LOAD

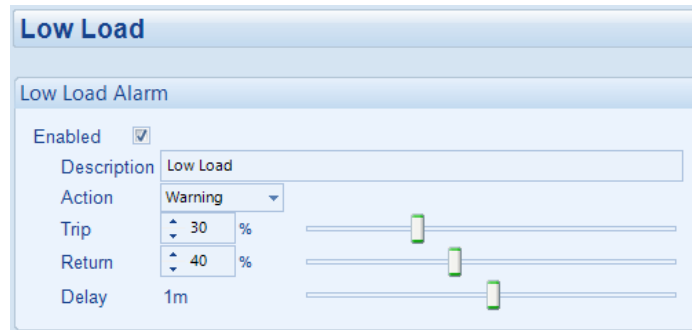

Parameter	Description
Enabled	<input type="checkbox"/> = <i>Low Load Alarm</i> is disabled. <input checked="" type="checkbox"/> = The <i>Low Load Alarm</i> activates when the generator power drops below the configured <i>Trip</i> setting longer than the configured <i>Delay</i> time. This is used to prevent the engine from running at very low load levels.
Description	Enter the LCD text that shows up on the display when this alarm activates.
Action	Select the action for the <i>Low Load Alarm</i> : Electrical Trip Indication Shutdown Warning
Trip	Set the percentage of total power at which the <i>Low Load Alarm</i> is activated.
Return	The Return level is only used for the <i>Warning Action</i> . When the load returns to above this percentage level of the total power, the <i>Warning</i> alarm is reset.
Delay	Set the amount of time before the <i>Low Load Alarm</i> activates.

2.7.6 AVR

AVR

Positive VAR

Pre-alarm

Trip %

Return %

Alarm

Action

Trip %

Delay

Negative VAR

Pre-alarm

Trip %

Return %

Alarm

Action

Trip %

Delay

Parameter	Description
AVR	<input type="checkbox"/> = Alarms are disabled. <input checked="" type="checkbox"/> = The module monitors the Positive & Negative VAR levels and provides an alarm when the level exceeds the <i>Trip</i> setting longer than the configured <i>Delay</i> setting.
Action	Select the action for the <i>Reverse Power Alarm</i> : Electrical Trip Shutdown

2.8 MAINS



= Only available on DSE7320 MKII AMF Modules

The *Mains* section is subdivided into smaller sections.
Select the required section with the mouse.

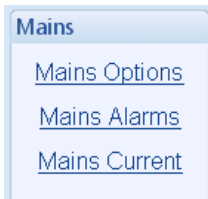

2.8.1 MAINS OPTIONS

Mains Options

Mains Options

Mains Failure Detection

Immediate Mains Dropout

AC System 3 Phase, 4 Wire

38

39

40

41

L1

N

L3





L2

VT fitted

Primary 111 3|E 110 Secondary

When three phase loads are present, it is usually desirable to set this parameter to to enable *Immediate Mains*

Parameters are detailed overleaf...

Parameter	Description
Mains Failure Detection 	<input type="checkbox"/> = The module ignores the status of the mains supply. <input checked="" type="checkbox"/> = The module monitors the mains supply and use this status for automatically starting and stopping the set in auto mode.
Immediate Mains Dropout 	<input type="checkbox"/> = Upon mains failure, the mains load switch is kept closed until the generator is up to speed and volts. <input checked="" type="checkbox"/> = Upon mains failure, the mains load switch is opened immediately, subject to the setting of the <i>mains transient</i> timer.
AC System 	<div style="border: 1px solid black; padding: 5px;"> <p>⚠NOTE: It is not possible to write the configuration to the module if the <i>Closed Transition</i> option is enabled and the <i>AC Systems</i> are not the same in the <i>Generator</i> and <i>Mains Options</i>.</p> </div> <div style="border: 1px solid black; padding: 5px; margin-top: 10px;"> <p>⚠NOTE: It is not possible to write the configuration to the module if the <i>CT Location</i> is set to <i>Load</i> and the <i>AC System</i> in the <i>Generator Options</i> and in the <i>Mains Options</i> are not the same.</p> </div> <p>The AC System of the mains is fixed to the same setting as the generator. These settings are used to detail the type of AC system to which the module is connected:</p> <ul style="list-style-type: none"> 2 Phase, 3 Wire L1 - L2 2 Phase, 3 Wire L1 - L3 3 Phase, 3 Wire 3 Phase, 4 Wire 3 Phase, 4 Wire Delta L1 - N - L2 3 Phase, 4 Wire Delta L1 - N - L3 3 Phase, 4 Wire Delta L2 - N - L3 Single Phase, 2 Wire Single Phase, 3 Wire L1 - L2 Single Phase, 3 Wire L1 - L3
VTs 	<input type="checkbox"/> = The voltage sensing to the controller is direct from the Mains. <input checked="" type="checkbox"/> = The voltage sensing to the controller is via Voltage Transformers (VTs or PTs). This is used to step down the generated voltage to be within the controller voltage specifications. By entering the <i>Primary</i> and <i>Secondary</i> voltages of the transformer, the controller displays the <i>Primary</i> voltage rather than the actual measured voltage. This is typically used to interface the DSE module to high voltage systems (i.e. 11 kV).

Mains Phase Rotation Alarm

Parameter	Description
Mains Phase Rotation IEEE 37.2 – 47 Phase Sequence Relay	<input type="checkbox"/> = Mains phase rotation is not checked. <input checked="" type="checkbox"/> = A mains failure is detected when the measured phase rotation is not as configured.





Breaker Control

Parameter	Description
Enable Breaker Alarms	<input type="checkbox"/> = Alarm is disabled. <input checked="" type="checkbox"/> = The <i>Mains Fail To Close Alarm</i> and the <i>Mains Fail To Open Alarm</i> are enabled. During the mains closure process, when the <i>Close Mains</i> output is activated, if the configured <i>Mains Closed Auxiliary</i> digital input does not become active within the <i>Mains Fail To Close Delay</i> timer, the <i>Mains Fail to Close</i> alarm is activated. Or, during the mains opening process, when the <i>Close Mains</i> output is deactivated, if the configured <i>Mains Closed Auxiliary</i> digital input does not become inactive within the <i>Mains Fail To Open Delay</i> timer, the <i>Mains Fail To Open</i> alarm is activated.

Mains Rating

Parameter	Description
Mains Rating	The Mains Rating is utilised to show the Mains load percentage in the DSE Scada Suite. The Mains kW and kVA rating must be correctly set. The values you set here are the kW, and kVA, NOT the kVA, or PF !

2.8.2 MAINS ALARMS

Alarm	IEEE designation
Mains Under Voltage IEEE 37.2 – 27 AC Undervoltage Relay 	<input type="checkbox"/> = Mains Under Voltage detection is disabled. <input checked="" type="checkbox"/> = Mains Under Voltage gives an alarm in the event of the mains voltage falling below the configured <i>Under Voltage Trip</i> value. The <i>Under Voltage Trip</i> value is adjustable to suit the application. The alarm is reset and the mains is considered within limits when the mains voltage rises above the configured <i>Under Voltage Return</i> level.
Mains Over Voltage IEEE 37.2 – 59 AC Overvoltage Relay 	<input type="checkbox"/> = Mains Over Voltage detection is disabled. <input checked="" type="checkbox"/> = Mains Over Voltage gives an alarm in the event of the mains voltage rising above the configured <i>Over Voltage Trip</i> value. The <i>Over Voltage Trip</i> value is adjustable to suit the application. The alarm is reset and the mains is considered within limits when the mains voltage falls below the configured <i>Over Voltage Return</i> level.
Mains Under Frequency IEEE 37.2 – 81 Frequency Relay 	<input type="checkbox"/> = Mains Under Frequency detection is disabled. <input checked="" type="checkbox"/> = Mains Under Frequency gives an alarm in the event of the mains frequency falling below the configured <i>Under Frequency Trip</i> value. The <i>Under Frequency Trip</i> value is adjustable to suit the application. The alarm is reset and the mains is considered within limits when the mains frequency rises above the configured <i>Under Frequency Return</i> level.
Mains Over Frequency IEEE 37.2 – 81 Frequency Relay 	<input type="checkbox"/> = Mains Over Frequency detection is disabled. <input checked="" type="checkbox"/> = Mains Over Frequency gives an alarm in the event of the mains frequency rising above the configured <i>Over Frequency Trip</i> value. The <i>Over Frequency Trip</i> value is adjustable to suit the application. The alarm is reset and the mains is considered within limits when the mains frequency falls below the configured <i>Over Frequency Return</i> level.

2.8.3 MAINS CURRENT

NOTE: Mains Current Alarms are provided on DSE7320 MKII modules only when the Current Transformers are fitted into the 'load leg'.

NOTE: These alarms are described fully in the section entitled *Generator Current Alarms* elsewhere in this manual.

Mains Current

Mains Current Options

CT Primary (L1,L2,L3,N)	600	A	
Full Load Rating	500	A	
Earth CT Primary	500	A	

Overcurrent Alarm

Immediate Warning

IDMT Alarm

Trip % 500 A

Time Multiplier

Action Electrical Trip

Short Circuit

Enabled

Action Electrical Trip

Trip % 1000 A

Time Multiplier

Earth Fault

Enable

Action Shutdown

Trip Level % 50.0 A

Time Multiplier

2.9 ENGINE

The *Engine* section is subdivided into smaller sections. Select the required section with the mouse.

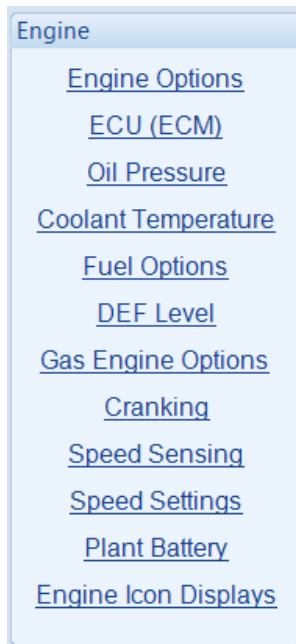

2.9.1 ENGINE OPTIONS

ECU (ECM) Options

ECU (ECM) Options

Engine Type Cummins CM2250

Enhanced J1939

Alternative Engine Speed

Modbus Engine Comms Port RS485 Port

Disable ECM Speed Control

These items are read only and not adjustable. To change these items, visit the *Module | Application* menu.

Parameter	Description
Disable ECM Speed Control	Disables speed control by the DSE module. Useful when an external device (i.e. remote speed potentiometer) is used to control engine speed.

Miscellaneous Options

NOTE: For a full list of the J1939-75 alarms and instrumentation, refer to DSE Publication: *057-253 DSE7310 MKII & DSE7320 MKII Operator Manual* which is found on our website: www.deepseaelectronics.com

Miscellaneous Options

J1939-75 Instrumentation Enable

J1939-75 Alarms Enable

CAN source address (instrumentation) 44

Parameter	Description
J1939-75 Instrumentation Enable	Allows the DSE module to be interrogated by another CAN device and transfer the generator set instrumentation over J1939 link.
J1939-75 Alarms Enable	Allows the DSE module to be interrogated by another CAN device and transfer the alarms over J1939 link.
CAN Source Address (Instrumentation)	Set the <i>CAN Source Address</i> for the DSE module over which other CAN bus devices read the generator set instrumentation.

Startup Options

Startup Options

Start Attempts 3

Parameter	Description
Start Attempts	<p>The number of starting attempts the module makes.</p> <p>If the module does not detect that the engine has fired before the end of the <i>Cranking Time</i>, then the current start attempt is cancelled and the <i>Crank Rest</i> time takes place before the next crank attempt begins.</p> <p>If, after all configured <i>start attempts</i>, the engine is not detected as running, the <i>Fail to Start</i> shutdown alarm is generated.</p> <p>The engine is detected as running by checking all methods of <i>Crank Disconnect</i>. For further details, see the section entitled <i>Crank Disconnect</i> elsewhere in this document.</p>

Pre-Heat

NOTE: For this feature to have effect, configure a digital output for *Pre-Heat*.

NOTE: Depending on *Engine Type* configuration, this is controlled direct by the ECU (ECM).

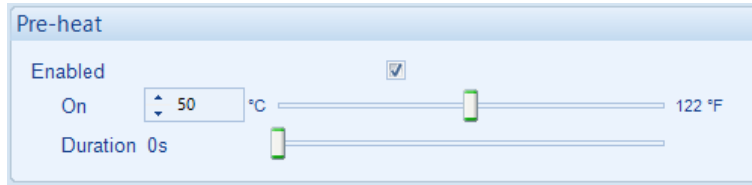

Parameter	Description
Enabled	<input type="checkbox"/> = Pre-heat is disabled. <input checked="" type="checkbox"/> = When the <i>Coolant Temperature</i> is below the configured <i>On</i> level, the <i>Pre-Heat</i> digital output is activated for the set <i>Duration</i> of time before cranking.
On	Set the coolant temperature below which the pre-heat is activated.
Duration	Set the time delay during which the <i>Pre-Heat</i> digital output remains active before cranking.

Post-Heat

NOTE: For this feature to have effect, configure a digital output for *Pre-Heat*.

NOTE: Depending on *Engine Type* configuration, this is controlled direct by the ECU (ECM).

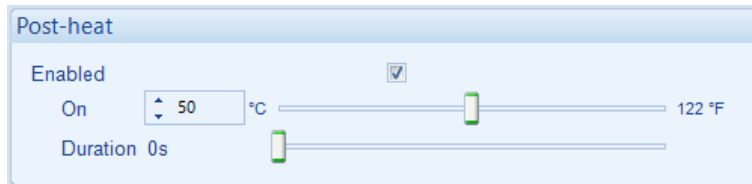

Parameter	Description
Enabled	<input type="checkbox"/> = Post-heat is disabled. <input checked="" type="checkbox"/> = When the <i>Coolant Temperature</i> is below the configured <i>On</i> level, the <i>Pre-Heat</i> digital output is activated for the set <i>Duration</i> of time after cranking and before the set is considered available.
On	Set the coolant temperature below which the pre-heat is activated.
Duration	Set the time delay during which the <i>Pre-Heat</i> digital output remains active after cranking and before the engine is considered available.

2.9.2 ECU (ECM)

The *ECU (ECM)* section is subdivided into smaller sections. Select the required section with the mouse.

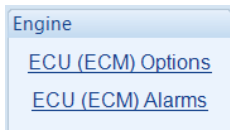

2.9.2.1 ECU (ECM) OPTIONS

Engine Hours

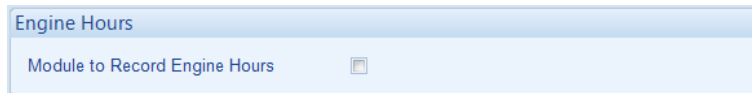

Parameter	Description
Module to Record Engine Hours	When enabled, DSE module counts Engine Run Hours. When disabled, Engine ECU (ECM) provides Run Hours.

DPF Regeneration Control

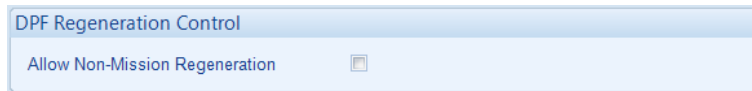

Parameter	Description
DPF Regeneration Control	Available for ECUs (ECM) which require the engine speed to drop during a manual regeneration cycle. During this time, the generator is not available to supply power and the under speed and under frequency alarms are not active.

Speed Switch

NOTE: Depending on the *EngineType* selected, the *Speed Switch* options vary to indicate certain speed switch methods such as disabling the speed switch.

Speed Switch

Enable Default Dataset ECU ▾

Parameter	Description
Speed Switch	<p>Defines the method of speed control over CAN bus when supported by the ECU (ECM). Selection needs to match the ECU (ECM) calibration for the speed control method.</p> <p>Available speed control methods to choose from:</p> <p>0: CAN Open Increase Decrease</p> <p>1: CAN Open Speed Demand</p> <p>2: Default Dataset ECU</p> <p>3: ECU Analogue Absolute</p> <p>4: ECU Analogue Relative</p> <p>5: ECU CAN Open Analogue</p> <p>6: ECU Frequency Input</p> <p>7: ECU Increase Decrease Input</p>

Example:

For some Volvo *Engine Types*, the *Speed Switch* indicates specific options as shown below.

Speed Switch

Enable Always ▾

Parameter	Description
Speed Switch Enable	<p>Defines the method of speed control over CAN bus when supported by the Volvo ECU (ECM). Selection needs to match the ECU (ECM) calibration for the speed control method.</p> <p>Available speed control methods to choose from:</p> <p>Always</p> <p>Never</p> <p>On Change</p>

ECU Wakeup

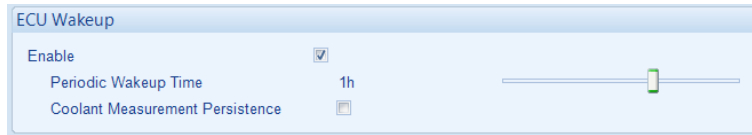

Parameter	Description
ECU Wakeup Enable	<input type="checkbox"/> = Option is disabled. <input checked="" type="checkbox"/> = When the engine is stopped, the DSE module sends a wakeup signal to the ECU (ECM) and keeps it powered up for the <i>ECU Override</i> time (configured in <i>Start Timers</i>) to read the ECU (ECM) parameters. This is periodically repeated depending on the configured <i>Periodic Wakeup Time</i> .
Coolant Measurement Persistence	<div style="border: 2px solid black; padding: 5px;"> <p>NOTE: Available only when <i>ECU Wakeup</i> is enabled.</p> </div> <input type="checkbox"/> = Option is disabled. <input checked="" type="checkbox"/> = The <i>Coolant Temperature</i> measurement is used for the <i>Coolant Temperature Control</i> .

ECU (ECM) Startup Delay

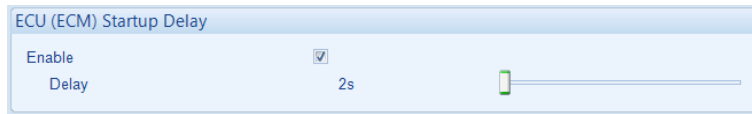

Parameter	Description
ECU Startup Delay	<input type="checkbox"/> = Option is disabled. <input checked="" type="checkbox"/> = When the engine has to start, the DSE module sends the wakeup signal to the ECU (ECM) before activating the <i>Fuel Relay</i> , <i>Start Relay</i> outputs, or sending the start signal by CAN message, and waits for the ECU to respond before sending the start request. If the ECU (ECM) doesn't respond within the <i>Delay</i> time, the module activates the <i>ECU Start Fail</i> alarm.

Droop

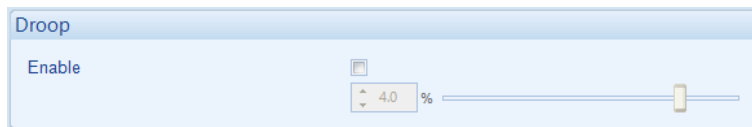

Parameter	Description
Droop	<div style="border: 2px solid black; padding: 5px;"> <p>NOTE: Droop options are only available where supported by the Engine ECU (ECM) over the CAN or MODBUS datalink. Contact the engine manufacturer for further details.</p> </div> <input type="checkbox"/> = Engine droop is not enabled. <input checked="" type="checkbox"/> = Where supported by the electronic engine ECU (ECM), the module enables droop in the engine ECU (ECM) governor at the configured percentage.

SPN Ignore List

SPN Ignore List			
	SPN	FMI	
1 <input checked="" type="checkbox"/>	8	Any	6 <input type="checkbox"/>
2 <input checked="" type="checkbox"/>	12	Any	7 <input type="checkbox"/>
3 <input checked="" type="checkbox"/>	52	Any	8 <input type="checkbox"/>
4 <input type="checkbox"/>			9 <input type="checkbox"/>
5 <input type="checkbox"/>			10 <input type="checkbox"/>

Parameter	Description
SPN Ignore List	Choose the specific SPN for the module to ignore. The module allows the engine to keep running when the ignored SPN occurs; however, depending on the severity, the engine shuts down based on the ECU (ECM) calibration. This is used to mask certain indications or warnings on the ECU (ECM) and not display them on the DSE module.

Miscellaneous

Miscellaneous	
CAN source address (engine messages)	220

Parameter	Description
CAN Source Address (Engine Messages)	Set the <i>CAN Source Address</i> the DSE module uses to communicate with the engine's ECU over the CAN bus connection. When an ECU <i>Engine Type</i> is selected in the <i>Application</i> section, the <i>CAN Source Address</i> is automatically configured to suit the engine ECU's default requirement. However in some cases a change is required depending on the ECU's configuration, contact the engine manufacturer for further details.

2.9.2.2 ECU (ECM) ALARMS

 **NOTE: This section is only available when the module is connected to an ECU.**

The *ECU (ECM) Alarms* section is subdivided into smaller sections. Select the required section with the mouse.

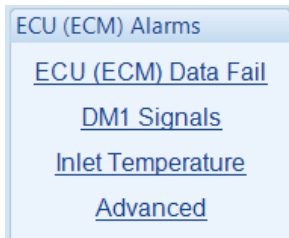

2.9.2.2.1 ECU (ECM) DATA FAIL

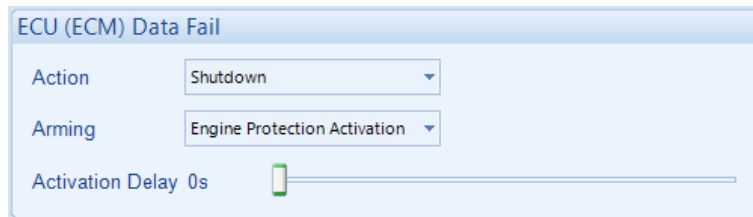

Parameter	Description
ECU (ECM) Data Fail	Provides protection against failure of the ECU (ECM) CAN data link. The alarm action list is as follows, see section entitled <i>Alarm Types</i> for more information: None Electrical Trip Shutdown Warning
Arming	Select when the <i>CAN ECU (ECM) Data Fail</i> alarm is active. Options are as follows: Always: The alarm is active at any time the CAN Link is lost Engine Protection Activation: The alarm is monitored after the engine is running and the oil pressure engine protection is in a 'healthy' state, until the engine stops. From Safety On: Active only after the <i>Safety On</i> delay timer From Starting: Active only after the <i>Crank Relay</i> is energised. Loading Alarms Activation: The alarm is monitored when the generator voltage and frequency are above their <i>Loading</i> levels. Never: Alarm is disabled When Stationary: Active only when the engine is not running
Activation Delay	The amount of time before the module activates the <i>CAN ECU (ECM) Data Fail</i> after a failure.

2.9.2.2.2 DM1 SIGNALS

NOTE: Configuration of parameters in this section only has effect when the ECU (ECM) supports these features.

NOTE: Configuration of the *Alarm Action* in this section defines the DSE module response to the CAN message; however, the ECU (ECM) still shuts down the engine depending on the alarm severity.

DM1 signals are messages from the CAN (ECM) ECU. The following parameters allows configuration of how the DSE module responds to these messages.

ECU Amber

The screenshot shows a configuration window titled "ECU Amber". It contains three settings:

- Action:** A dropdown menu currently set to "Warning".
- Arming:** A dropdown menu currently set to "Always".
- Activation Delay:** A slider control set to "0s".

Parameter	Description
ECU Amber Action	The action the DSE module takes when receiving an ECU Amber fault condition. The alarm action list is as follows, see section entitled <i>Alarm Types</i> for more information: None Electrical Trip Shutdown Warning
Arming	Select when the DSE module activates its <i>ECU Amber</i> alarm. Options are as follows, see the section entitled <i>Alarm Arming</i> elsewhere in this document: Always Engine Protection Activation From Safety On From Starting Loading Alarms Activation Never When Stationary
Activation Delay	The amount of time before the module activates the <i>ECU Amber</i> alarm after receiving an ECU Amber fault condition from the ECU.

ECU Red

The screenshot shows a configuration window titled "ECU Red". It contains three settings:

- Action:** A dropdown menu currently showing "Shutdown".
- Arming:** A dropdown menu currently showing "From Safety On".
- Activation Delay:** A slider control set to "0s".

Parameter	Description
ECU Red Action	The action the DSE module takes when receiving an ECU Red fault condition. The alarm action list is as follows, see section entitled <i>Alarm Types</i> for more information: None Electrical Trip Shutdown Warning
Arming	Select when the DSE module activates its <i>ECU Red</i> alarm. Options are as follows, see the section entitled <i>Alarm Arming</i> elsewhere in this document: Always Engine Protection Activation From Safety On From Starting Loading Alarms Activation Never When Stationary
Activation Delay	The amount of time before the module activates the <i>ECU Red</i> alarm after receiving an ECU Red fault condition from the ECU.

ECU Malfunction

The screenshot shows a configuration window titled "ECU Malfunction". It contains three settings:

- Action:** A dropdown menu currently showing "Warning".
- Arming:** A dropdown menu currently showing "Always".
- Activation Delay:** A slider control set to "0s".

Parameter	Description
ECU Malfunction Action	The action the DSE module takes when receiving an ECU Malfunction fault condition. The alarm action list is as follows, see section entitled <i>Alarm Types</i> for more information: None Electrical Trip Shutdown Warning
Arming	Select when the DSE module activates its <i>ECU Malfunction</i> alarm. Options are as follows, see the section entitled <i>Alarm Arming</i> elsewhere in this document: Always Engine Protection Activation From Safety On From Starting Loading Alarms Activation Never When Stationary
Activation Delay	The amount of time before the module activates the <i>ECU Malfunction</i> alarm after receiving an ECU Malfunction fault condition from the ECU.

ECU Protect

The screenshot shows a configuration window titled "ECU Protect". It contains three settings:

- Action:** A dropdown menu currently showing "Warning".
- Arming:** A dropdown menu currently showing "From Safety On".
- Activation Delay:** A slider bar set to "0s".

Parameter	Description
ECU Protect Action	The action the DSE module takes when receiving an ECU Protect fault condition. The alarm action list is as follows, see section entitled <i>Alarm Types</i> for more information: None Electrical Trip Shutdown Warning
Arming	Select when the DSE module activates its <i>ECU Protect</i> alarm. Options are as follows, see the section entitled <i>Alarm Arming</i> elsewhere in this document: Always Engine Protection Activation From Safety On From Starting Loading Alarms Activation Never When Stationary
Activation Delay	The amount of time before the module activates the <i>ECU Protect</i> alarm after receiving an ECU Protect fault condition from the ECU.

2.9.2.2.3 INLET TEMPERATURE

Provides inlet temperature alarms when the module is used in conjunction with electronic (ECU) engines that support the reading of inlet temperature.

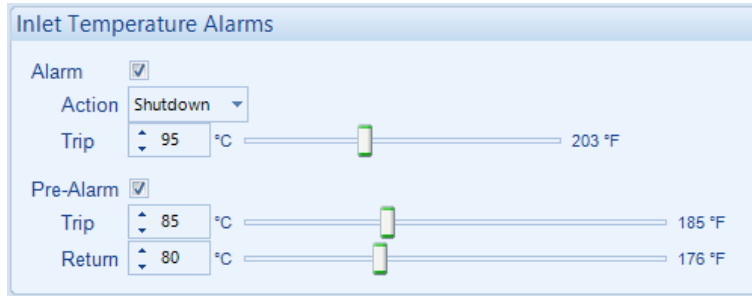

Parameter	Description
Inlet Temperature Alarm	<p>NOTE: The feature is only available when an electronic engine is selected.</p> <p><input type="checkbox"/> = Disable the alarm <input checked="" type="checkbox"/> = <i>Inlet Temperature Alarm</i> is activated when the <i>Inlet Temperature</i> sent from the ECU rise above the <i>Trip</i> level.</p>
Action	<p>Select the type of alarm required from the list:</p> <p>Electrical Trip Shutdown</p> <p>For details of these, see the section entitled <i>Alarm Types</i> elsewhere in this document.</p>
Inlet Temperature Pre-Alarm	<p><input type="checkbox"/> = The alarm is disabled. <input checked="" type="checkbox"/> = <i>Inlet Temperature Pre-Alarm</i> is activated when the <i>Inlet Temperature</i> sent from the ECU is above the configured <i>Trip</i> level The Pre-Alarm is deactivated when the <i>Inlet Temperature</i> falls below the <i>Return</i> level.</p>

2.9.2.2.4 ADVANCED

NOTE: Configuration of parameters in this section only has effect when the ECU (ECM) supports the features.

Allows configuration of selected additional CAN messages from the engine ECU (ECM).

DPTC Filter

DPTC Filter

Enabled

Action Warning

Arming From Safety On

Parameter	Description
DPTC Filter Enabled	<p><input type="checkbox"/> = The DSE module's <i>DPTC Filter</i> alarm is disabled, it does not act upon any DPTC Filter fault conditions from the ECU.</p> <p><input checked="" type="checkbox"/> = The DSE module's <i>DPTC Filter</i> alarm is enabled. The action the DSE module takes when receiving a DPTC Filter fault condition from the ECU. The alarm action list is as follows, see section entitled <i>Alarm Types</i> The alarm actionlist is as follows, see section entitled <i>Alarm Types</i> for more information:</p> <p>Electrical Trip Indication Shutdown Warning</p>
Arming	<p>Select when the DSE module activates its <i>DPTC Filter</i> alarm. Options are as follows, see the section entitled <i>Alarm Arming</i> elsewhere in this document:</p> <p>Always Engine Protection Activation From Safety On From Starting Loading Alarms Activation When Stationary</p>

HEST Active

Parameter	Description
HEST Active Enabled	<p><input type="checkbox"/> = The DSE module's <i>HEST</i> alarm is disabled, it does not act upon any HEST fault conditions from the ECU.</p> <p><input checked="" type="checkbox"/> = The DSE module's <i>HEST</i> alarm is enabled. The action the DSE module takes when receiving a HEST fault condition from the ECU.</p> <p>The alarm action list is as follows, see section entitled <i>Alarm Types</i> The alarm action list is as follows, see section entitled <i>Alarm Types</i> for more information:</p> <p>Indication Warning</p>
Arming	<p>Select when the DSE module activates its <i>HEST</i> alarm.</p> <p>Options are as follows, see the section entitled <i>Alarm Arming</i> elsewhere in this document:</p> <p>Always Engine Protection Activation From Safety On From Starting Loading Alarms Activation When Stationary</p>

DEF Level

Parameter	Description
DEF Level Enabled	<p><input type="checkbox"/> = The DSE module's <i>DEF Level</i> alarm is disabled, it does not act upon any DEF Level fault conditions from the ECU.</p> <p><input checked="" type="checkbox"/> = The DSE module's <i>DEF Level</i> alarm is enabled. The action the DSE module takes when receiving a DEF Level fault condition from the ECU.</p> <p>The alarm action list is as follows, see section entitled <i>Alarm Types</i> The alarm action list is as follows, see section entitled <i>Alarm Types</i> for more information:</p> <p>Electrical Trip Shutdown Warning</p>
Arming	<p>Select when the DSE module activates its <i>DEF Level</i> alarm.</p> <p>Options are as follows, see the section entitled <i>Alarm Arming</i> elsewhere in this document:</p> <p>Always Engine Protection Activation From Safety On From Starting Loading Alarms Activation When Stationary</p>
Activation Delay	<p>The amount of time before the module activates the <i>DEF Level</i> alarm after a receiving a DEF Level fault condition from the ECU.</p>

SCR Inducement

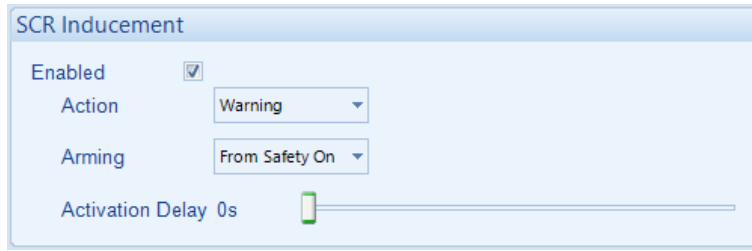

Parameter	Description
SCR Inducement Enabled	<p><input type="checkbox"/> = The DSE module's <i>SCR Inducement</i> alarm is disabled, it does not act upon any SCR Inducement fault conditions from the ECU.</p> <p><input checked="" type="checkbox"/> = The DSE module's <i>SCR Inducement</i> alarm is enabled. The action the DSE module takes when receiving a SCR Inducement fault condition from the ECU. The alarm action list is as follows, see section entitled <i>Alarm Types</i> The alarm action list is as follows, see section entitled <i>Alarm Types</i> for more information:</p> <p>Electrical Trip</p> <p>Shutdown</p> <p>Warning</p>
Arming	<p>Select when the DSE module activates its <i>SCR Inducement</i> alarm. Options are as follows, see the section entitled <i>Alarm Arming</i> elsewhere in this document:</p> <p>Always</p> <p>Engine Protection Activation</p> <p>From Safety On</p> <p>From Starting</p> <p>Loading Alarms Activation</p> <p>When Stationary</p>
Activation Delay	<p>The amount of time before the module activates the <i>SCR Inducement</i> alarm after a receiving a SCR Inducement fault condition from the ECU.</p>

2.9.3 OIL PRESSURE

NOTE: The DSE module reads oil pressure from the ECU (ECM) if the selected Engine Application supports it. In these cases, Analogue Input A is configured as Flexible Analogue or Digital Input. Configuration of Flexible Analogue Inputs and Digital Inputs is detailed elsewhere in this document.

Input Type



Parameter	Description
Input Type	Select the sensor type and curve from a pre-defined list or create a user-defined curve. Resistive: for sensors with maximum range of 0 Ω to 480 Ω Current: for sensors with maximum range of 0 mA to 20 mA Voltage: for sensors with maximum range of 0 V to 10 V

Sensor Open Circuit Alarm

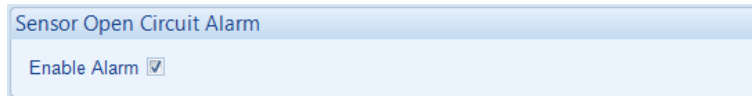

Parameter	Description
Enable Alarm	<input type="checkbox"/> = Alarm is disabled. <input checked="" type="checkbox"/> = The <i>Low Oil Pressure Open Circuit Alarm</i> is active when the module detects an open circuit when the sensor is disconnected.

Low Oil Pressure Alarms

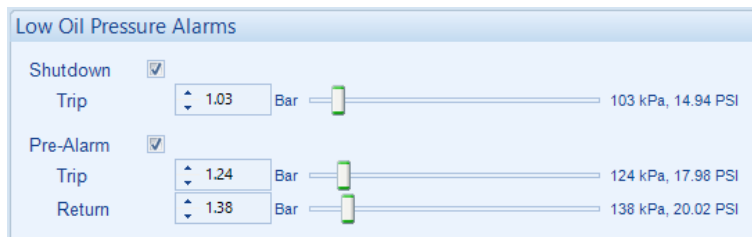

Parameter	Description
Low Oil Pressure Shutdown	<input type="checkbox"/> = Alarm is disabled. <input checked="" type="checkbox"/> = The <i>Low Oil Pressure Shutdown Alarm</i> is active when the measured oil pressure drops below the configured <i>Trip</i> level.
Low Oil Pressure Pre-Alarm	<input type="checkbox"/> = Alarm is disabled. <input checked="" type="checkbox"/> = The <i>Low Oil Pressure Warning Alarm</i> is active when the measured oil pressure drops below the configured <i>Trip</i> level. The warning is automatically reset when the oil pressure increases above the configured <i>Return</i> level.

2.9.4 COOLANT TEMPERATURE

The *Coolant Temperature* page is subdivided into smaller sections. Select the required section with the mouse.

Coolant Temperature

[Coolant Temperature Alarms](#)

[Coolant Temperature Control](#)

2.9.4.1 COOLANT TEMPERATURE ALARM

NOTE: The DSE module reads oil pressure from the ECU (ECM) if the selected Engine Application supports it. In these cases, Analogue Input B is configured as Flexible Analogue or Digital Input. Configuration of Flexible Analogue Inputs and Digital Inputs is detailed elsewhere in this document.

Input Type

Input Type

VDO 120 °C Edit...

Click to edit the sensor curve. See section entitled *Editing The Sensor Curve*.

Parameter	Description
Input Type	Select the sensor type and curve from a pre-defined list or create a user-defined curve.

Sensor Open Circuit Alarm

Sensor Open Circuit Alarm

Enable Alarm

Parameter	Description
Enable Alarm	<input type="checkbox"/> = Alarm is disabled. <input checked="" type="checkbox"/> = The <i>Coolant Temperature Open Circuit Alarm</i> is active when the module detects an open circuit when the sensor is disconnected.

Low Coolant Temperature Alarms

Low Coolant Temperature Alarms

Pre-Alarm

Trip °C 158 °F

Return °C 167 °F

Parameter	Description
Low Coolant Temperature Pre-Alarm	<input type="checkbox"/> = Alarm is disabled. <input checked="" type="checkbox"/> = The <i>Low Coolant Temperature Warning Alarm</i> is active when the measured coolant temperature falls below the configured <i>Trip</i> level. The <i>Warning</i> is automatically reset when the coolant temperature rises above the configured <i>Return</i> level.

High Coolant Temperature Alarms

High Coolant Temperature Alarms

Pre-Alarm

Return °C 190 °F

Trip °C 194 °F

Electrical Trip

Trip °C 198 °F

Shutdown

Trip °C 203 °F

Parameter	Description
High Coolant Temperature Pre-Alarm	<input type="checkbox"/> = Alarm is disabled. <input checked="" type="checkbox"/> = The <i>High Coolant Temperature Warning Alarm</i> is active when the measured coolant temperature rises above the configured <i>Trip</i> level. The <i>Warning</i> is automatically reset when the coolant temperature falls below the configured <i>Return</i> level.
High Coolant Temperature Electrical Trip	<input type="checkbox"/> = Alarm is disabled. <input checked="" type="checkbox"/> = The <i>High Coolant Temperature Controlled Shutdown Alarm</i> is active when the measured coolant temperature rises above the configured <i>Trip</i> level.
High Coolant Temperature Shutdown	The <i>High Coolant Temperature Shutdown Alarm</i> is active when the measured coolant temperature rises above the configured <i>Trip</i> level.

2.9.4.2 COOLANT TEMPERATURE CONTROL

Coolant Heater Control

Parameter	Description
Coolant Heater Control	<input type="checkbox"/> = Coolant Heater Control function is disabled. <input checked="" type="checkbox"/> = The digital output configured to <i>Coolant Heater Control</i> is energised when the engine coolant temperature falls below the configured <i>On</i> level. This is designed to control an external engine heater. When the coolant temperature rises above the configured <i>Off</i> level, the digital output is de-energised.

Coolant Cooler Control

Parameter	Description
Coolant Cooler Control Enable	<input type="checkbox"/> = Coolant Cooler Control function is disabled. <input checked="" type="checkbox"/> = The digital output configured to <i>Coolant Cooler Control</i> is energised when the engine coolant temperature exceeds the configured <i>On</i> level. This is designed to control an external engine cooling system, for instance an additional cooling fan. When the coolant temperature falls below the configured <i>Off</i> level, the digital output is then de-energised.
Disable When Set Not Available	<input type="checkbox"/> = The <i>Coolant Cooler Control</i> operates as normal. <input checked="" type="checkbox"/> = The <i>Coolant Cooler Control</i> operates only when the generator is running.

Fan Control

Parameter	Description
Fan Control	An output configured to <i>Fan Control</i> energises when the engine becomes available (up to speed). This output is designed to control an external cooling fan. When the engine stops, the cooling fan remains running for the duration of the <i>Fan Overrun Delay</i> .

2.9.5 FUEL OPTIONS

The *Fuel Level* page is subdivided into smaller sections. Select the required section with the mouse.

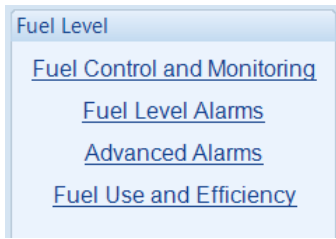

2.9.5.1 FUEL CONTROL AND MONITORING

Input Type

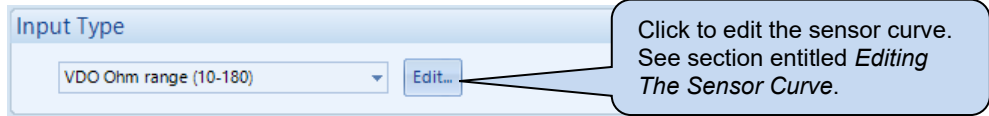

Parameter	Description
Input Type	Select the sensor type and curve from a pre-defined list or create a user-defined curve

In the case of a parallel sided fuel tank, an accurate measure of the fuel level is easily made, however this is not the case with non-parallel sided fuel tanks. Alteration to the fuel level sensor curve is required for non-parallel sided to attain more accurate level indication. This is because a fuel level sensor measures the distance between the top of the tank and the fuel level.

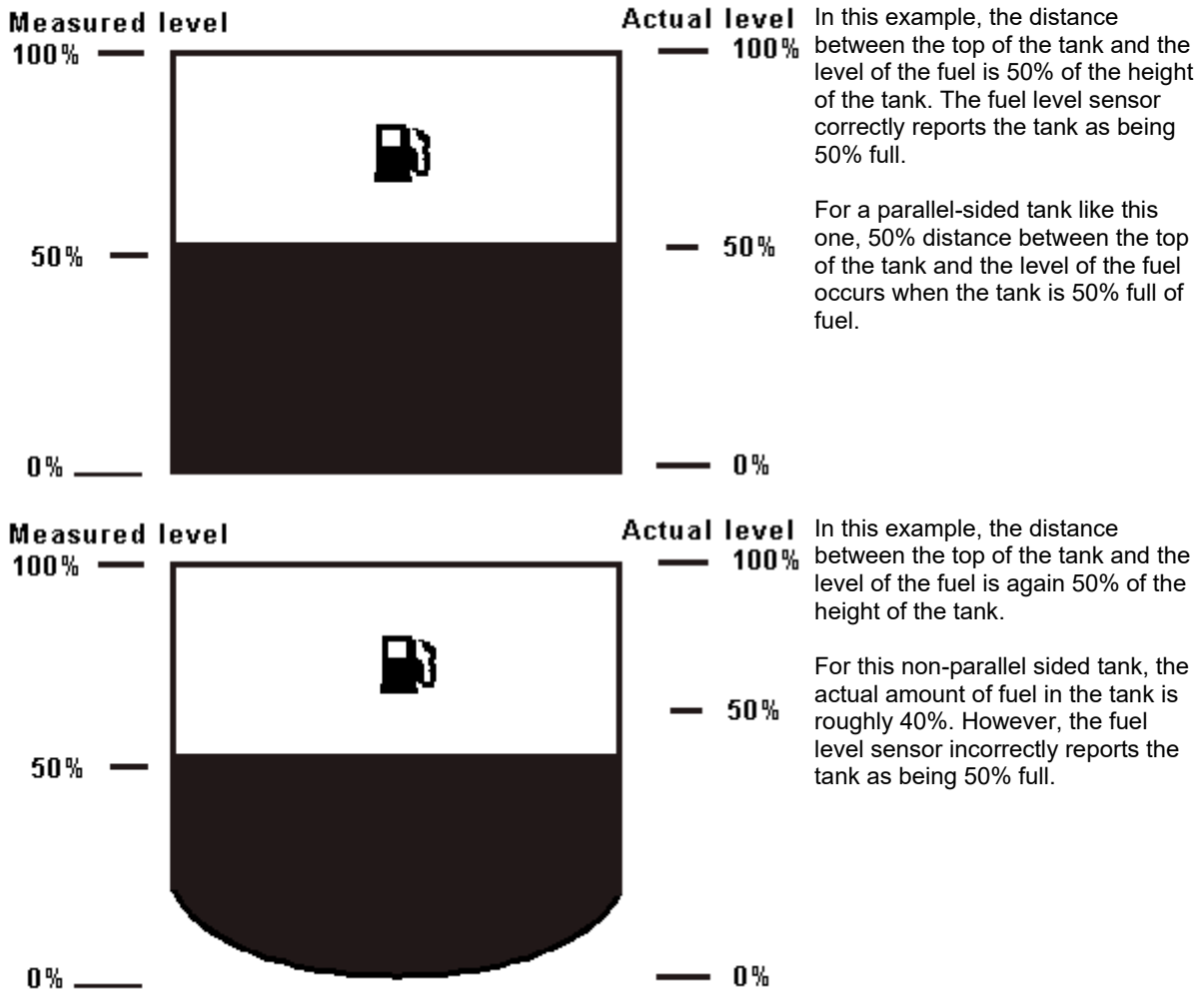

Fuel Pump Control

Parameter	Description
Fuel Pump Control Enable	<input type="checkbox"/> = Fuel Pump Control is disabled. <input checked="" type="checkbox"/> = Allows the module to control an external fuel pump to transfer fuel from a bulk tank to the day tank. A digital output configured for <i>Fuel Pump Control</i> energises when the fuel level falls below the configured <i>On</i> setting and de-energises when the fuel level exceeds the configured <i>Off</i> setting.

Fuel Monitoring

NOTE: Sending events by SMS is only available when the module is configured to communicate to a supported modem by RS232. Refer to section entitled *RS232 Port* elsewhere in this document for further details.

Parameter	Description
Fuel Tank Size	Select the tank size and the units for the module's display: Imperial Gallons Litres US Gallons
Logging Interval	The interval at which the fuel level is stored in the event log.
Dial Out on Logging	<input type="checkbox"/> = Dial Out on Logging is disabled. <input checked="" type="checkbox"/> = Dial Out on Logging is enabled. When the <i>Fuel Level</i> is recorded in the module's event log, the module dials the pre-configured number of a PC.
SMS Enabled	<input type="checkbox"/> = <i>Fuel Level Values</i> are not sent by SMS message. <input checked="" type="checkbox"/> = The value of the <i>Fuel Level</i> is sent by SMS message at the configured SMS Interval based on the Logging Interval.
Stable Timer	The controller maintains a rolling record of the fuel level percentage for the duration of the <i>Stable Timer</i> . When the rolling record of the fuel level percentage indicates that the fuel level has increased more than the <i>Change Indicating Filling</i> during the <i>Stable Timer</i> , the controller records a <i>Fuel Filling Start</i> event in its event log. When the rolling record of the fuel level indicates that the fuel level has not changed more than the <i>Change Indicating Stable</i> during the <i>Stable Timer</i> , the controller records a <i>Fuel Filling Stop</i> event in its event log.

Parameter descriptions are continued overleaf...

Parameter	Description
Change Indicating Filling	<p>When the fuel level increases at a rate higher than</p> <p><u>Change Indicating Filling</u> <i>Stable Timer</i></p> <p>Then a fuel fill start event is recorded into the event log. Depending on configuration this generates a dial out or SMS message.</p> <p>Example <i>Stable Timer = 1 minute</i> <i>Change Indicating Filling = 3 %</i></p> <p>When the fuel level increases by more than 3% in 1 minute, a fuel fill event is recorded.</p>
Change Indicating Stable	<p>During filling, if the fuel level increases at a rate less than</p> <p><u>Change Indicating Stable</u> <i>Stable Timer</i></p> <p>then a fuel fill end event is recorded into the event log. Depending on configuration this generates a dial out or SMS message.</p> <p>Example: <i>Stable Timer = 1 minute</i> <i>Change Indicating Stable = 2 %</i></p> <p>When the fuel level increases by less than 2% in 1 minute, a fuel fill end event is recorded.</p>

Fuel Usage Alarm

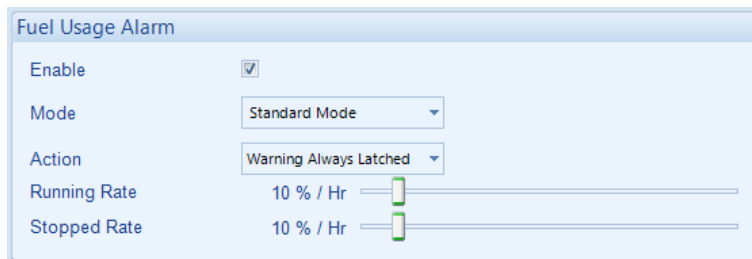

Parameter	Description
Fuel Usage Alarm	<p>Provides an alarm to monitor the usage of the fuel.</p> <p>The alarm activates when the fuel level drops at a higher rate than the configured <i>Running Rate</i> while the engine is running. Or if the fuel level drops at a higher rate than the configured <i>Stopped Rate</i> while the engine is stopped.</p> <p>This alarm is provided to check for fuel leakage problems or potential fuel theft.</p>
Mode	<p>Standard Mode: The fuel usage alarm activates when the fuel level decreases at a higher rate per hour than the configured <i>Running Rate</i> while the engine is running, or <i>Stopped Rate</i> while the engine is stopped.</p> <p>Sampling Window: The fuel usage alarm activates when the fuel level decreases at a higher rate per <i>Sampling Window</i> than the configured <i>Running Rate</i> while the engine is running, or <i>Stopped Rate</i> while the engine is stopped.</p>

2.9.5.2 FUEL LEVEL ALARMS

Sensor Open Circuit Alarm

Sensor Open Circuit Alarm

Enable Alarm

Parameter	Description
Sensor Open Circuit Alarm	<input type="checkbox"/> = Alarm is disabled. <input checked="" type="checkbox"/> = The <i>Fuel Level Open Circuit Alarm</i> is active when the module detects an open circuit when the sensor is disconnected.

Low Fuel Level Alarms

Low Fuel Level Alarms

Alarm

Action Shutdown

Trip 25 %

Delay 0s

Pre-Alarm

Trip 30 %

Return 40 %

Delay 0s

Parameter	Description
Low Fuel Level Alarm	<input type="checkbox"/> = Alarm is disabled. <input checked="" type="checkbox"/> = The <i>Low Fuel Level Alarm</i> activates with the configured <i>Action</i> when the measured fuel level drops below the <i>Trip</i> setting for the configured <i>Delay</i> time.
Action	<p> NOTE: For details of these, see the section entitled <i>Alarm Types</i> elsewhere in this document.</p> <p>Select the type of alarm required from the list: Electrical Trip Shutdown</p>
Low Fuel Level Pre-Alarm	<input type="checkbox"/> = Alarm is disabled. <input checked="" type="checkbox"/> = The <i>Low Fuel Level Pre-Alarm</i> activates with the configured <i>Action</i> when the measured fuel level drops below the <i>Low Pre-Alarm Trip</i> setting for the configured <i>Delay</i> time. The pre-alarm is automatically reset when the fuel level exceeds the configured <i>Low Pre-Alarm Return</i> setting.

High Fuel Level Alarms

The screenshot shows a configuration window titled "High Fuel Level Alarms". It is divided into two main sections: "Pre-Alarm" and "Alarm".

- Pre-Alarm:**
 - Checked (checkbox).
 - Return: 95% (with a slider).
 - Trip: 100% (with a slider).
 - Delay: 0s (with a slider).
- Alarm:**
 - Checked (checkbox).
 - Action: Shutdown (dropdown menu).
 - Trip: 105% (with a slider).
 - Delay: 0s (with a slider).

Parameter	Description
High Fuel Level Pre-Alarm	<input type="checkbox"/> = Alarm is disabled. <input checked="" type="checkbox"/> = The <i>High Fuel Level Pre-Alarm</i> activates with the configured <i>Action</i> when the measured fuel level rises above the <i>High Pre-Alarm Trip</i> setting for the configured <i>Delay</i> time. The pre-alarm is automatically reset when the fuel level drops below the configured <i>High Pre-Alarm Return</i> setting.
High Fuel Level Alarm	<input type="checkbox"/> = Alarm is disabled. <input checked="" type="checkbox"/> = The <i>High Fuel Level Alarm</i> activates with the configured <i>Action</i> when the measured fuel level raises above the <i>Trip</i> setting for the configured <i>Delay</i> time.
Action	<div style="border: 1px solid black; padding: 5px;"> <p>NOTE: For details of these, see the section entitled <i>Alarm Types</i> elsewhere in this document.</p> </div> <p>Select the type of alarm required from the list: Electrical Trip Shutdown</p>

2.9.5.3 ADVANCED ALARMS

Water in Fuel

Water In Fuel

Action Warning ▾

Arming Always ▾

Activation Delay 0s

Parameter	Description
Action	<p>The alarm activates when a <i>Water in Fuel</i> alarm is received from the engine ECU, or if a digital input configured for <i>Water in Fuel</i> activates for longer than the configured <i>Activation Delay</i> timer.</p> <p>The alarm action list is as follows, see section entitled <i>Alarm Types</i> for more information:</p> <p>None Electrical Trip Shutdown Warning</p>
Arming	<p>Select when the alarm is active, see section entitled <i>Alarm Arming</i> for more information:</p> <p>Always Engine Protection Activation From Safety On From Starting Loading Alarms Activation Never When Stationary</p>

Fuel Tank Bund

Fuel Tank Bund

Action Warning

Arming Always

Activation Delay 0s

Parameter	Description
Action	<p>The alarm goes active when a digital input configured for <i>Fuel Tank Bund Level High</i> activates for longer than the configured <i>Activation Delay</i> timer.</p> <p>The input is designed to connect to a level switch within the tank bund (sometimes known as the Fuel Retention Tank). This is used to detect fuel leaks and/or overflows.</p> <p>The alarm action list is as follows, see section entitled <i>Alarm Types</i> for more information:</p> <p>None Electrical Trip Shutdown Warning</p>
Arming	<p>Select when the alarm is active, see section entitled <i>Alarm Arming</i> for more information:</p> <p>Always Engine Protection Activation From Safety On From Starting Loading Alarms Activation Never When Stationary</p>

2.9.5.4 FUEL USE AND EFFICIENCY

Engine Efficiency Curve

Parameter	Description
Engine Type	Select the engine type from a pre-defined list or create a user-defined curve.
Specific Gravity	The relative fuel density of the fuel (usually given as kg/m ³) being consumed by the generator.

Instrumentation Sources

Parameter	Description
Instantaneous Fuel Consumption	Not Used: <i>Instantaneous Fuel Consumption</i> is not displayed. Efficiency Curve: The DSE module calculates the <i>Instantaneous Fuel Consumption</i> as Litre/hour from <i>Generator Total kW Percentage</i> using the <i>Efficiency Curve</i> and <i>Specific Gravity</i> . Engine ECU: The DSE module reads the <i>Instantaneous Fuel Consumption</i> as Litre/hour from the engine ECU.
Trip Average Fuel Consumption	Not Used: <i>Trip Average Fuel Consumption</i> is not displayed. Efficiency Curve: The DSE module calculates the <i>Trip Average Fuel Consumption</i> as litre/hour over the current or last run from <i>Generator Total kW Percentage</i> using the <i>Efficiency Curve</i> and <i>Specific Gravity</i> . Engine ECU: The DSE module reads the <i>Trip Average Fuel Consumption</i> as litre/hour over the current or last run from the engine ECU. Module Sensor: The DSE module calculates the <i>Trip Average Fuel Consumption</i> as litre/hour over the current or last run from the change in fuel tank level using the <i>Fuel Tank Size</i> .
Trip Fuel Usage	Not Used: <i>Trip Fuel Usage</i> is not displayed. Efficiency Curve: The DSE module calculates the <i>Trip Fuel Usage</i> as litres over the current or last run from <i>Generator Total kW Percentage</i> using the <i>Efficiency Curve</i> and <i>Specific Gravity</i> . Engine ECU: The DSE module reads the <i>Trip Fuel Usage</i> as litres over the current or last run from the engine ECU. Module Sensor: The DSE module calculates the <i>Trip Fuel Usage</i> as litres over the current or last run from the change in fuel tank level using the <i>Fuel Tank Size</i> .

Parameter descriptions are continued overleaf...

Parameter	Description
Accumulated Fuel Usage	<p>Not Used: <i>Accumulated Fuel Usage</i> is not displayed.</p> <p>Efficiency Curve: The DSE module calculates the <i>Accumulated Fuel Usage</i> as litres over the entire run time from <i>Generator Total kW Percentage</i> using the <i>Efficiency Curve</i> and <i>Specific Gravity</i>.</p> <p>Engine ECU: The DSE module reads the <i>Accumulated Fuel Usage</i> as litres over the entire run time from the engine ECU.</p> <p>Module Sensor: The DSE module calculates the <i>Accumulated Fuel Usage</i> as litres over the entire run time from the change in fuel tank level using the <i>Fuel Tank Size</i>.</p>
Instantaneous Efficiency	<p>Not Used: <i>Instantaneous Efficiency</i> is not displayed.</p> <p>Efficiency Curve: The DSE module calculates the <i>Instantaneous Efficiency</i> as kWh/litre from <i>Generator Total kW Percentage</i> using the <i>Efficiency Curve</i> and <i>Specific Gravity</i>.</p> <p>Engine ECU: The DSE module reads the <i>Instantaneous Fuel Consumption</i> as Litre/hour from the engine ECU and calculates the <i>Instantaneous Efficiency</i> as kWh/litre using the <i>Generator Total kW Percentage</i>.</p>
Trip Average Efficiency	<p>Not Used: <i>Trip Average Efficiency</i> is not displayed.</p> <p>Efficiency Curve: The DSE module calculates the <i>Trip Average Efficiency</i> as kWh/litre over the current or last run from <i>Generator Total kW Percentage</i> using the <i>Efficiency Curve</i> and <i>Specific Gravity</i>.</p> <p>Engine ECU: The DSE module reads the <i>Trip Average Fuel Consumption</i> as Litre/hour from the engine ECU over the current or last run and calculates the <i>Trip Average Efficiency</i> as kWh/litre using the <i>Generator Total kW Percentage</i>.</p> <p>Module Sensor: The DSE module calculates the <i>Trip Average Efficiency</i> as kWh/litre over the current or last run from the change in fuel tank level using the <i>Fuel Tank Size</i> and <i>Generator Total kW Percentage</i>.</p>
Estimate Run Time to Empty	<p>Not Used: <i>Estimate Run Time to Empty</i> is not displayed.</p> <p>Engine ECU: The DSE module reads the <i>Instantaneous Fuel Consumption</i> as Litre/hour from the engine ECU and <i>Estimates Run Time to Empty</i> using the <i>Fuel Tank Size</i>.</p> <p>Module Sensor: The DSE module <i>Estimates Run Time to Empty</i> using the <i>Run Time Until Empty</i> parameters.</p>

Run Time Until Empty

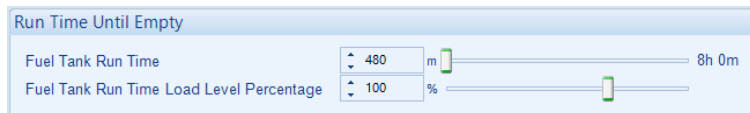

Parameter	Description
Fuel Tank Run Time	The time in minutes how long the generator's fuel tank last when running at the <i>Fuel Tank Run Time Load Level Percentage</i> .
Fuel Tank Run Time Load Level Percentage	The percentage of full load kW the generator which is used to calculate how long the fuel in the tank lasts.

2.9.6 DEF LEVEL

NOTE: Configuration of alarms in this section only has effect when the ECU (ECM) supports DEF Level.

NOTE: Configuration of the *Alarm Action* in this section defines the DSE module response to the CAN bus message; however, the ECU (ECM) still shuts down the engine depending on the alarm severity.

DEF Level is a CAN bus message from the ECU (ECM). The following parameters allow configuration of how the DSE module responds to the DEF Level.

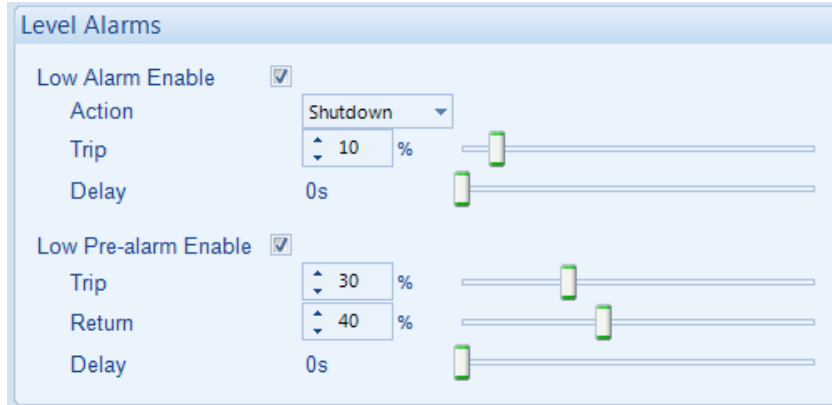

Parameter	Description
DEF Level Low Alarm	<input type="checkbox"/> = Disable the alarm. <input checked="" type="checkbox"/> = DEF Low Alarm will be activated when the DEF Level sent from the ECU is below the configured Trip level for longer than the configured Delay time.
Action	Select the type of alarm required from the list: Shutdown Electrical Trip For details of these, see the section entitled <i>Alarm Types</i> elsewhere in this document.
DEF Level Low Pre-Alarm	<input type="checkbox"/> = The Pre-alarm is disabled. <input checked="" type="checkbox"/> = DEF Low Pre-Alarm will be activated when the DEF Level sent from the ECU is below the configured Trip level for longer than the configured Delay time. The Pre-Alarm is deactivated when the DEF Level rises above the Return level.

2.9.8 GAS ENGINE OPTIONS

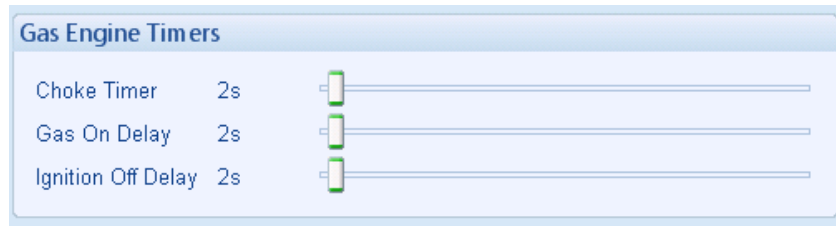

Parameter	Description
Choke Timer	Controls the amount of time that the Gas Choke output is active during the starting sequence.
Gas On Delay	Controls the amount of time between energising the Gas Ignition and energising the Fuel output. Used in the starting sequence to purge old gas from the engine.
Ignition Off Delay	Controls the amount of time between de-energising the Fuel output and de-energising the Gas Ignition output. Used in the stopping sequence to purge unburnt gas from the engine before it is stopped.

2.9.9 CRANKING

Cranking settings are used to detect when the set fires during the starting sequence.

As the set is cranked, the first parameter that passes its *Crank Disconnect* setting results in the cessation of the cranking signal.

Having more than one *crank disconnect* source allows for a much faster crank disconnect response leading to less wear on the engine and starter components and provides added safety in case one source is lost, by a blown or tripped fuse for example.

Options



When *Check Oil Pressure Prior to Starting* is enabled, the cranking is not allowed if the oil pressure is not seen as being low. This is used as a *double check* that the engine is stopped before the starter is engaged.

Parameter	Description
Crank Disconnect on Oil Pressure	<input type="checkbox"/> = The DSE module does not use oil pressure to decide when to disengage the starter motor. <input checked="" type="checkbox"/> = The DSE module does use oil pressure to decide when to disengage the starter motor in addition to the enabled methods.
Check Oil Pressure Prior to Starting	<input type="checkbox"/> = The DSE module does not use oil pressure as an indication if the engine is running. This is disabled for large engines that have an electrical oil pump which is used to maintain oil pressure even when the engine is stationary. <input checked="" type="checkbox"/> = The DSE module uses oil pressure as an indication if the engine is running.

Crank Disconnect

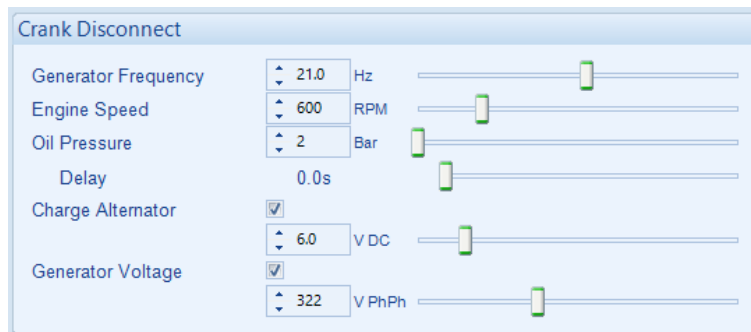

Parameter	Description
Generator Frequency	The DSE module disengages the starter motor when the generator frequency rises above the configured level.
Engine Speed	The DSE module disengages the starter motor when the engine speed rises above the configured level.
Oil Pressure	The DSE module disengages the starter motor when the engine oil pressure rises above the configured level for longer than the <i>Oil Pressure Delay time</i> .
Charge Alternator	<input type="checkbox"/> = The DSE module does not use charge alternator voltage to decide when to disengage the starter motor. <input checked="" type="checkbox"/> = The DSE module disengages the starter motor when the charge alternator voltage rises above the configured level.
Generator Voltage	<input type="checkbox"/> = The DSE module does not use the generator voltage to decide when to disengage the starter motor. <input checked="" type="checkbox"/> = The DSE module disengages the starter motor when the generator voltage rises above the configured level.

Manual Crank

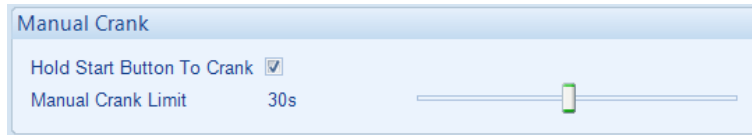

Parameter	Description
Hold Start Button To Crank	<input type="checkbox"/> = Manual Crank is disabled. <input checked="" type="checkbox"/> = Press and hold the <i>Start</i> button to crank in <i>Manual</i> mode, releasing the <i>Start</i> button during a manual start disconnects the crank.
Manual Crank Limit Timer	Manual Crank Limit protects the engine from being cranked too long in case of a start failure. This is the maximum time to crank the engine when the <i>Start</i> button is kept pressed.

2.9.10 SPEED SENSING

Options

Disable ECM Speed Sensing

Magnetic Pickup Fitted Engine speed is read from the ECU (ECM)

Flywheel Teeth

Enable Multiple Engage Attempts

Engage Attempts

Loss of Sensing Signal

Disable under speed alarms if sensor fails

Magnetic pickup open circuit

Parameter	Description
Disable ECM Speed Sensing	<input type="checkbox"/> = An ECM is connected to the DSE module and being used for speed sensing. <input checked="" type="checkbox"/> = An ECM is connected to the DSE module but another form of speed sensing fitted to the DSE module is being used.
Magnetic Pickup Fitted	<div style="border: 2px solid black; padding: 5px; margin-bottom: 5px;"> <p>NOTE: For specifications of the magnetic pickup input, refer to DSE Publication: 057-253 DSE7310 MKII & DSE7320 MKII Operator Manual which is found on our website: www.deepseaelectronics.com</p> </div> <input type="checkbox"/> = Magnetic pickup device is not connected to the DSE module. <input checked="" type="checkbox"/> = A low impedance magnetic pickup device is connected to the DSE module to measure engine speed.
Flywheel Teeth	Define the number of pulses which are counted by the speed sensing device in each engine revolution.
Enable Multiple Engage Attempts	<input type="checkbox"/> = No engage attempt is given. If no speed sensing is detected during cranking, the <i>Fail To Start</i> alarm is active. <input checked="" type="checkbox"/> = If no magnetic pickup pulses are detected during cranking, it is assumed that the starter has not engaged to turn the engine. The starter is withdrawn and re-energised for the configured number of <i>Engage Attempts</i> .
Loss of Sensing Signal	If the speed sensing signal is lost during engine running (or not present during cranking when <i>Multiple Engage Attempts</i> is enabled), an alarm is generated: <i>Shutdown:</i> The engine is removed from load and is immediately stopped. <i>Warning:</i> The engine continues to run, however a warning alarm is raised.
Disable Under Speed Alarms If Sensor Fails	<input type="checkbox"/> = Under speed alarms activate even if speed sensor has failed. <input checked="" type="checkbox"/> = Under speed alarms are disabled when the speed sensor fails.
Magnetic Pickup Open Circuit	If the magnetic pickup device is not detected, an alarm is generated: <i>Shutdown:</i> The engine is removed from load and is immediately stopped. <i>Warning Always Latched:</i> The engine continues to run, however a latched warning alarm is raised even if the magnetic pickup signal returns to normal.

2.9.11 SPEED SETTINGS

Under Speed

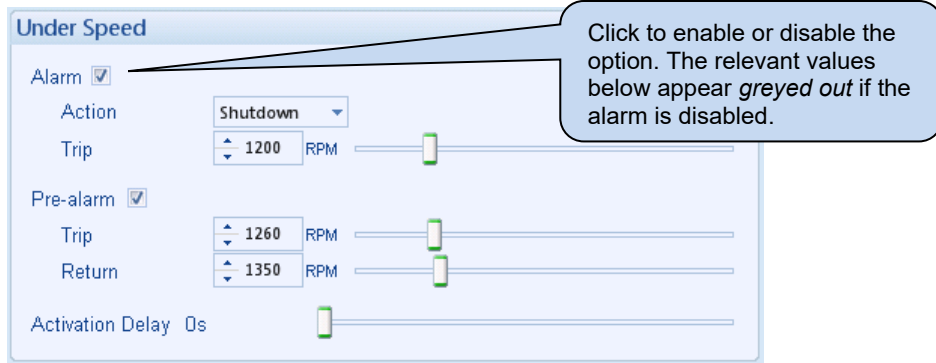

Parameter	Description
Under Speed Alarm	<input type="checkbox"/> = <i>Under Speed</i> alarm is disabled. <input checked="" type="checkbox"/> = Under Speed gives an alarm in the event of the engine speed falling below the configured <i>Under Speed Alarm Trip</i> value for longer than the <i>Activation Delay</i> . The <i>Under Speed Alarm Trip</i> value is adjustable to suit user requirements.
Action	Select the type of alarm required from the list: Shutdown Electrical Trip For details of these, see the section entitled <i>Alarm Types</i> elsewhere in this document.
Under Speed Pre-Alarm	<input type="checkbox"/> = <i>Under Speed Warning</i> alarm is disabled. <input checked="" type="checkbox"/> = Under Speed gives a warning alarm in the event of the engine speed falling below the configured <i>Under Speed Pre-Alarm Trip</i> value for longer than the <i>Activation Delay</i> . The <i>Under Speed Pre-Alarm Trip</i> value is adjustable to suit user requirements.

Over Speed

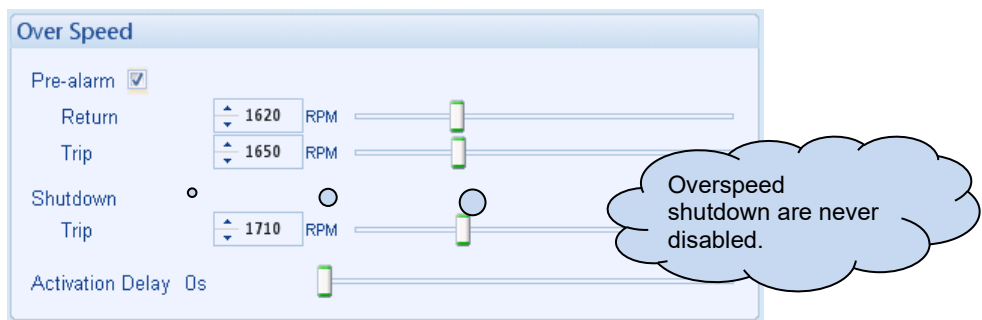

Parameter	Description
Over Speed Pre-Alarm	<input type="checkbox"/> = Alarm is disabled. <input checked="" type="checkbox"/> = Over Speed gives a warning alarm in the event of the engine speed rising above the configured <i>Over Speed Pre-Alarm Trip</i> value for longer than the <i>Activation Delay</i> . The <i>Warning</i> is automatically reset when the engine speed falls below the configured <i>Return</i> level. The <i>Over Speed Pre-Alarm Trip</i> value is adjustable to suit user requirements.
Over Speed Alarm	<input type="checkbox"/> = Alarm is disabled. <input checked="" type="checkbox"/> = Over Speed gives a <i>Shutdown</i> alarm in the event of the engine speed rising above the configured <i>Over Speed Alarm Trip</i> value for longer than the <i>Activation Delay</i> . The <i>Over Speed Alarm Trip</i> value is adjustable to suit user requirements.

Run Away

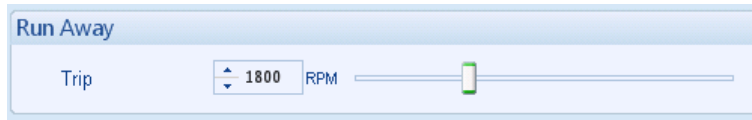

Parameter	Description
Run Away	<input type="checkbox"/> = Alarm is disabled. <input checked="" type="checkbox"/> = In the event of the engine speed rising above the configured <i>Trip</i> value the <i>Run Away Shutdown</i> alarm is immediately triggered. This is used to protect against engine damage due to uncontrolled speed increase, where the engine speed runs away.
Trip	Set the speed level for the <i>Run Away</i> alarm.

Overspeed Options

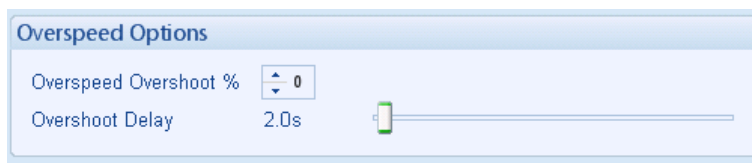

Parameter	Description
Overspeed Overshoot %	To prevent spurious overspeed alarms at engine start up, the module includes configurable <i>Overspeed Overshoot</i> protection. This allows the engine speed to 'overshoot' the Overspeed setting during the starting process for a short time. Rather than 'inhibiting' the Overspeed alarms, the levels are temporarily raised by the <i>Overspeed Overshoot %</i> for the duration of the <i>Overspeed Overshoot</i> delay from starting.
Overshoot Delay	

2.9.12 PLANT BATTERY

Voltage Alarms

Parameter	Description
Plant Battery Under Voltage IEEE 37.2 -27 DC Undervoltage Relay	The alarm activates when the battery voltage drops below the configured <i>Pre-Alarm</i> level for the configured <i>Delay</i> time. When the battery voltage rises above the configured <i>Return</i> level, the alarm is de-activated.
Plant Battery Over Voltage IEEE 37.2 -59 DC Overvoltage Relay	The alarm activates when the battery voltage rises above the configured <i>Pre-Alarm</i> level for the configured <i>Delay</i> time. When the battery voltage drops below the configured <i>Return</i> level, the alarm is de-activated.

Charge Alternator Alarm

Parameter	Description
Use Module For Charge Alternator	<p>NOTE: The feature is only available when an electronic engine is selected.</p> <p>When enabled, DSE module measures the charge alternator voltage. When disabled, Engine ECU (ECM) provides charge alternator voltage.</p>
Charge Alternator Shutdown Alarm	The alarm activates when the charge alternator voltage falls below the configured <i>Trip</i> level for the configured <i>Delay</i> time.
Charge Alternator Warning Alarm	The alarm activates when the charge alternator voltage falls below the configured <i>Trip</i> level for the configured <i>Delay</i> time.

2.9.13 ENGINE ICON DISPLAYS

This section is used with Electronic Engines, it allows to create or define a CAN Lamp icon and how to be displayed when the configured alarm or message is active, such as flashing the CAN icon rapidly or slowly. The first screen is enabled by default, and it cannot be disabled, the second and third screens are configurable to be enabled or disabled through this section to allow the user to create more CAN Icon Displays. The CAN icon instrument is activated based on a DTC message sent from the ECU or according to GenComm instrumentation conditions.

2.9.13.1 TITLE INSTRUMENTATION

Select the display form of the DEF Tank Level instrument in the relevant screen.







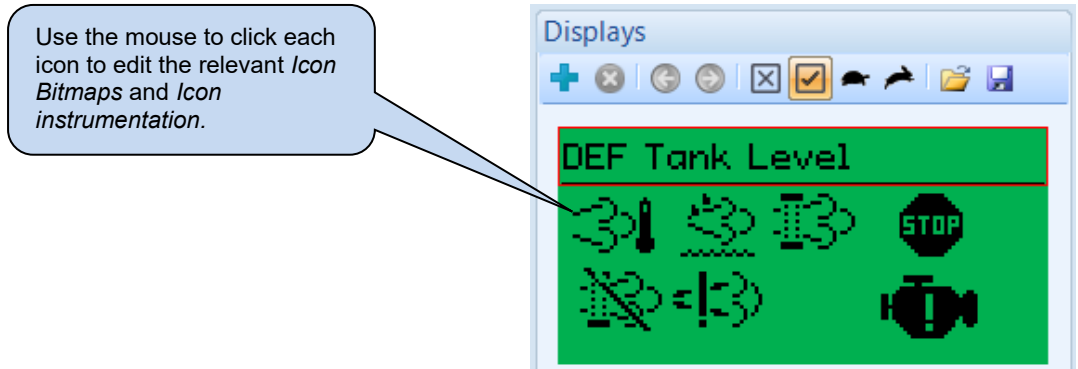

Title Instrumentation	Display
Not Used	The <i>DEF Tank Level</i> is not displayed in the title of the screen.
DEF Tank Level (Gauge)	<p>The <i>DEF Tank Level</i> is displayed in form of bar gauge meter </p> <p>The DEF Tank Level (gauge) display is flashed slowly or rapidly on the screen if the conditions and values are configured and the instrument readings are satisfied.</p>
DEF Tank Level (numeric)	The <i>DEF Tank Level</i> is displayed in numeric form

2.9.13.2 ICON INSTRUMENTATION

Displays

Select the required Lamp Icon from the screen to configure or click on the  tab to create a new Lamp Icon.



Display tab tools	Description
	Click on the Plus tab to create a new Lamp Icon within the selected screen.
	Click on the delete tab to delete the selected Lamp Icon from the screen.
	Click on the right or left tab to select the next Lamp Icon in the screen.
	Click to hide the instruments from the screens.
	Click to show all the instruments in the screens.
	This tool is for flashing demonstration. Click to flash all the instruments slowly.
	This tool is for flashing demonstration. Click to flash all the instruments rapidly.
	Click to import a saved <i>Engine Icon Displays</i> .
	Click to export the configured <i>Engine Icon Displays</i> .





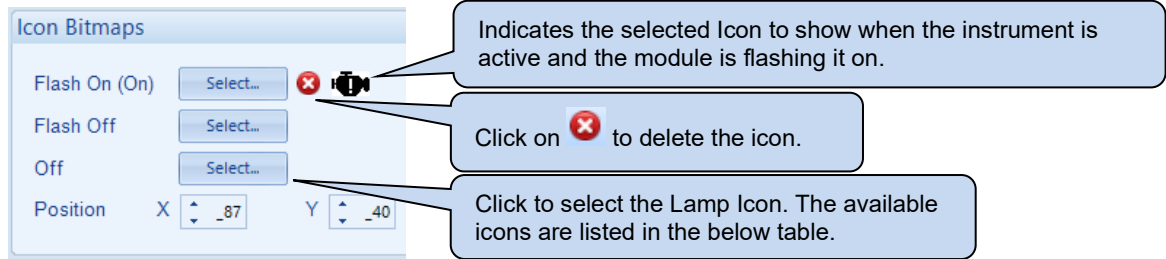





Icon Bitmaps

Configure the Icon Bitmaps of the selected instrument from the screen, to show the Lamp Icon when it is active or inactive



Icon Bitmaps	Description
Flash On (On)	Select the icon to show when the instrument is active and the module has flashed on the <i>Engine Icons</i> on the screen.
Flash Off	Select the icon to show when the instrument is active and the module has flashed off the <i>Engine Icons</i> on the screen.
Off	Select the icon to show when the instrument is not active on the screen.
Position X, Y	Configure the instrument positions for X & Y coordinates on the screen.

Continued Overleaf...

Lamp Icons	Display
	DEF On Large
	DEF On
	DPF Active
	DPF Inhibit
	DPF Stop
	DPF Warning
	ECU Red Alarm
	ECU Yellow Alarm
	HEST On
	SCR Active Large
	SCR Active

Icon Instrumentation

Configure the Type of the Instrumentation to read from the DTC or from a GenComm register, and on what condition(s) the selected instrument to be On or flashing.

Icon Instrumentation DTC Type

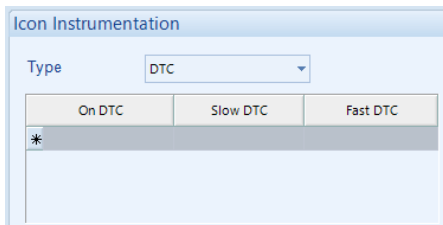

Icon Instrumentation	Description
On DTC	Configure the DTC code to activate the instrument when <i>On DTC</i> satisfied.
Slow DTC	Configure the DTC code to flash the instrument slowly when <i>Slow DTC</i> satisfied.
Fast DTC	Configure the DTC code to flash the instrument rapidly when <i>Fast DTC</i> satisfied.

Icon Instrumentation GenComm Type

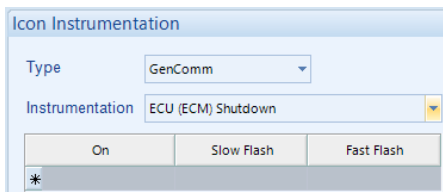

Parameters detailed overleaf...

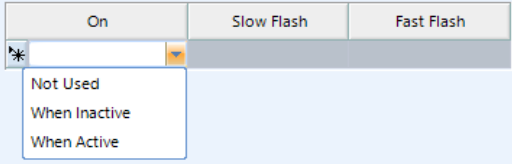
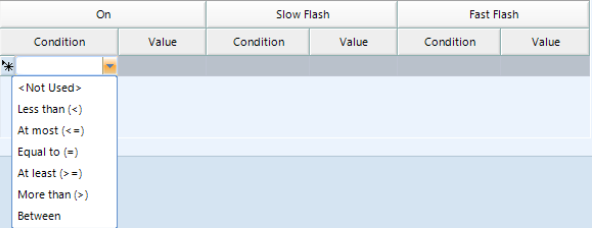
Icon Instrumentation	Description
Instrumentation	Select the instrument to monitor. This could be a flag condition or an instrumentation value.
Flag type of GenComm Icon Instrument	<p>Select the required Condition to activate the Instrumentation Icon, or to Slow Flash, or to Fast Flash based on the options below:</p> <p><i>Not Used</i> <i>When Inactive</i> <i>When Active</i></p> 
Instrumentation type of GenComm Icon Instrument	<p>Configure the required Condition to activate the Instrumentation Icon, or to Slow Flash, or to Fast Flash.</p> 

2.10 COMMUNICATIONS

The *Communications* page is subdivided into smaller sections. Select the required section with the mouse.



2.10.1 COMMUNICATION OPTIONS

Provides a means of giving the controller an identity. This is used in the SCADA section to allow the operator to see the site name and engine identity that it is currently connected to.

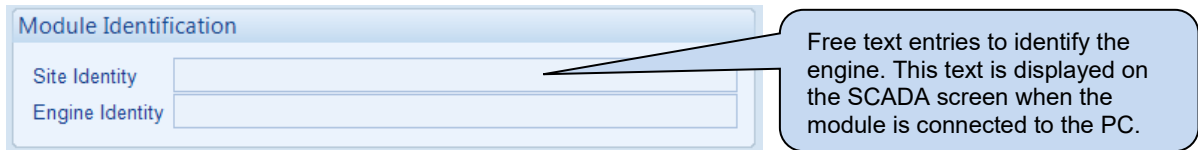

Parameter	Description
Site Identity	A free entry boxes to allow the user to give the DSE module a description of where the site is located. This text is not shown on the module's display and is only seen when performing remote communication. This aids the user in knowing where the generator is located.
Genset Identity	A free entry boxes to allow the user to give the DSE module a description of which generator it is connected to. This text is not shown on the module's display and is only seen when performing remote communication. This aids the user in knowing which generator on a specific site is being monitored.

2.10.2 RS232 PORT

The *RS232 Port* section is subdivided into smaller sections. Select the required section with the mouse.

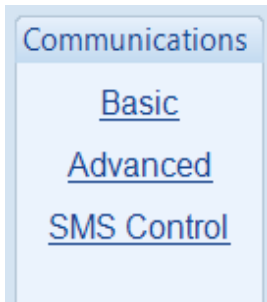

2.10.2.1 BASIC

Serial Port Configuration

 **NOTE:** Connecting a modem directly to the module's RS232 for is legacy support only. When a new installation requires remote communication using the cellular network is required, refer to DSE products DSE890, DSE891 and DSEWebNet on the DSE website: www.deepseaelectronics.com.

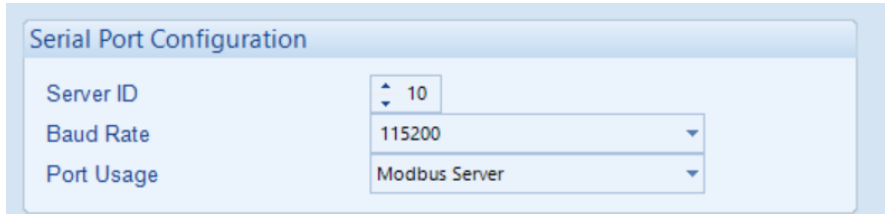

Parameter	Description
Server ID	Select the server ID of the DSE module's RS232 port.
Baud Rate	Select the Baud Rate (speed of communication) of the DSE module's RS232 port. Every device on the RS232 link must have the same Baud Rate. 1200 2400 4800 9600 14400 19200 28800 38400 57600 115200
Port Usage	<p>Modbus server: RS232 ports is used for direct RS232 connection to PLC, BMS etc</p> <p>Incoming Modem Calls: RS232 port connected to modem, used to accept incoming calls from a PC only.</p> <p>Incoming And Outgoing Modem (Sequence): RS232 port connected to modem used to accept incoming calls from a PC and also make calls upon events. When multiple <i>Alarm Numbers</i> are configured, the module attempts to dial each number. When the dial out call fails to one of the configured numbers, the module attempts to call that number for the configured number of <i>Retries</i>, before it carries on to the next number.</p> <p>Incoming And Outgoing Modem (Cyclic): RS232 port connected to modem used to accept incoming calls from a PC and also make calls upon events. When multiple <i>Alarm Numbers</i> are configured, the module attempts to dial each number. When the dial out call fails to one of the configured numbers, the module completes the cycle and re-attempts to call those numbers for the configured number of <i>Retries</i>.</p> <p>Outgoing Modem Alarms (Sequence): RS232 port connected to modem, used to make calls upon events. When multiple <i>Alarm Numbers</i> are configured, the module attempts to dial each number. When the dial out call fails to one of the configured numbers, the module attempts to call that number for the configured number of <i>Retries</i>, before it carries on to the next number.</p> <p>Outgoing Modem Alarms (Cyclic): RS232 port connected to modem, used to make calls upon events. When multiple <i>Alarm Numbers</i> are configured, the module attempts to dial each number. When the dial out call fails to one of the configured numbers, the module completes the cycle and re-attempts to call those numbers for the configured number of <i>Retries</i>.</p>

Modem Settings

NOTE: Connecting a modem directly to the module's RS232 for is legacy support only. When a new installation requires remote communication using the cellular network is required, refer to DSE products DSE890, DSE891 and DSEWebNet on the DSE website: www.deepseaelectronics.com.

Parameter	Description
Alarm Numbers	The phone number that the module dials upon an event. This number must be connected to a PC modem on a PC running the DSE Configuration Suite Software. Leave this field empty when dial-out to a PC is not required.
GSM Modem	<input type="checkbox"/> = The connected modem is a fixed line telephone modem. <input checked="" type="checkbox"/> = The connected modem is a GSM (cellular) modem. The GSM signal strength meter and GSM operator are shown on the module display.
SMS Message Centre Number	The Message centre used to send SMS messages. This number is obtained from the GSM operator.
SMS Recipient Numbers	Numbers of the cell phones to send SMS messages to. Leave blank if SMS function is not required.
Send Extended Instrumentation	<input type="checkbox"/> = The SMS message that is sent only contains information about the event. <input checked="" type="checkbox"/> = When the module sends an SMS message for an event, it also contains information about the generator (such as oil pressure) at the time the event occurred.
Send as Flash Message	<input type="checkbox"/> = The type of SMS message that is sent is standard. <input checked="" type="checkbox"/> = The type of SMS message that is sent is a flash message. A flash SMS is a type of message that without user action appears directly and full screen on the phone.

2.10.2.2 ADVANCED

NOTE: Connecting a modem directly to the module's RS232 for is legacy support only. When a new installation requires remote communication using the cellular network is required, refer to DSE products DSE890, DSE891 and DSEWebNet on the DSE website: www.deepseaelectronics.com.

Initialisation Strings

Initialisation Strings	
Init (not auto answer)	E0S7=60S0=0&S0&C1&D3
Init (auto answer)	E0S7=60S0=2&S0&C1&D3
Hangup	H0

The initialisation strings are commands that are sent to the modem upon powering up the DSE module and additionally at regular intervals subsequently, whenever the DSE module *Initialises* (resets) the modem.

Factory Set Initialisation Strings

Parameter	Description
E0	Echo off
S7=60	Wait for carrier time 60s
S0=0 (not auto answer)	Do not answer
S0=2 (auto answer)	Answer after two rings
&S0	DSR always on
&C1	DCD is active if modem is online
&D3	Reset (ATZ) on DTR-drop
H0	Hang up (disconnect)

Silent Operation

The modem connected to the DSE controller usually makes dialling noises and 'squeal' in the initial stages of making a data call. To control this noise, add the following command to the end of the initialisation string:

Parameter	Description
M0	Silent operation
M1	Sounds during the initial stages of making a data call
M2	Sounds always when connected (not recommended for troubleshooting)

Sierra/Wavecom Fastrak Supreme GSM Modem Initialisation Strings

When connected to the Wavecom Fastrak Supreme GSM modem, the initialisation strings must be altered by changing the factory set &D3 to &D2.

Initialisation Strings	
Init (not auto answer)	E057=6050=0&S0&C1&D2
Init (auto answer)	E057=6050=2&S0&C1&D2
Hangup	H0

Parameter	Description
&D2 (required for Sierra / Wavecom Fastrak Supreme)	Hang up on DTR-drop
&D3 (DSE module factory settings)	Reset on DTR-drop

Other Modems

When using modems not recommended by DSE, first try either of the options shown above. If problems are still encountered, contact your modem supplier for further advice.

Connection Settings

Connection Settings	
Client inactivity timeout	5s
Connect delay	60s
Retries	4
Retry delay	5s
Repeat cycle delay	10s
Modbus	
Inter-frame delay	0 ms

Parameter	Description
Client Inactivity Timeout	The module monitors by default the USB port for communications. When activity is detected on the RS232 port, the module monitors the port for further data. If no data activity is detected on the port for the duration of the <i>client Inactivity Timer</i> , it reverts to looking at the USB port. This needs to be set longer than the time between Modbus polls from the client.
Connect Delay	The amount of time that is allowed to elapse between the alarm being registered and the controller dialling out with the fault.
Retries	The number of times the module attempts to contact the remote PC by modem.
Retry Delay	The amount of time between retries.
Repeat Cycle Delay	The amount of time between the cycle repeats when dialling out calls to multiple <i>Alarm Numbers</i> fails.
Inter-frame Delay	Set the time delay between the DSE module receiving a MODBUS RTU request and the DSE module's response.

2.10.2.3 SMS CONTROL

NOTE: Connecting a modem directly to the module's RS232 for is legacy support only. When a new installation requires remote communication using the cellular network is required, refer to DSE products DSE890, DSE891 and DSEWebNet on the DSE website: www.deepseaelectronics.com.

Parameter	Description
Require PIN	<input type="checkbox"/> = A control code sent by SMS does not require a PIN code entered before the code. <input checked="" type="checkbox"/> = For security, the configured <i>PIN Prefix</i> must be entered in the SMS prior to the control code.
Start Off Load (Code 1)	<input type="checkbox"/> = Sending code 1 to the module via SMS does not issue a <i>Start Off Load</i> command. <input checked="" type="checkbox"/> = When in Auto mode, the module performs the start sequence but the engine is not instructed to take the load when code 1 is sent via SMS. This function is used where an engine only run is required e.g. for exercise.
Start On Load (Code 2)	<input type="checkbox"/> = Sending code 2 to the module via SMS does not issue a <i>Start On Load</i> command. <input checked="" type="checkbox"/> = When in auto mode, the module performs the start sequence and transfer load to the engine when code 2 is sent via SMS.
Cancel (Code 3)	<input type="checkbox"/> = Sending code 3 to the module via SMS does not issue a cancel the start command issued by code 1 or 2. <input checked="" type="checkbox"/> = Sending code 3 to the module via SMS cancels the start command issued by code 1 or 2.
Stop Mode (Code 4)	<input type="checkbox"/> = Sending code 4 to the module via SMS does not issue place the unit into its <i>Stop Mode</i> . <input checked="" type="checkbox"/> = Sending code 4 to the module via SMS mimics the operation of the 'Stop' button and is used to provide a remote SMS stop command.
Auto Mode (Code 5)	<input type="checkbox"/> = Sending code 5 to the module via SMS does not issue place the unit into its <i>Auto Mode</i> . <input checked="" type="checkbox"/> = Sending code 5 to the module via SMS mimics the operation of the Auto button.

2.10.2.4 TROUBLESHOOTING MODEM COMMUNICATIONS

 **NOTE: Connecting a modem directly to the module's RS232 for is legacy support only. When a new installation requires remote communication using the cellular network is required, refer to DSE products DSE890, DSE891 and DSEWebNet on the DSE website: www.deepseaelectronics.com.**

2.10.2.4.1 MODEM COMMUNICATION SPEED SETTING

First ensure the modem is set to communication with the DSE module at 9600 baud – Modems supplied by DSE are factory adjusted to operate with the DSE module. Only modems purchased from a third party may require adjustment.

To change the modems RS232 baud rate you need a command line terminal program (HyperTerminal by Microsoft is a good solution). Operation of this terminal program is not supported by DSE; contact your terminal program supplier.

Connect the modem RS232 port to your PCs RS232 port. You may need an additional card in your PC to provide this facility.

Use HyperTerminal (or similar) to connect to the modem at its current baud rate. You may need to contact your modem supplier to obtain this detail. If this is not possible, use 'trial and error' methods. Select a baud rate, attempt connection, press <ENTER> a few times. If the modem responds with **OK** then you are connected at the correct baud rate. Any other response (including nothing) means you are not connected so select another baud rate.

When connected, enter the following command:

AT+IPR=9600 and press <ENTER>
This sets the modem to 9600 baud.

Close the HyperTerminal connection (**do not** remove power from the modem) then open a new connection to the modem at 9600 baud.

Enter the following command:

AT&W and press <ENTER>

This saves the new setting in the modem. Power is now removed. The next time power is applied, the modem starts with the new settings (Baud rate = 9600), suitable to communicate with the DSE module.

2.10.2.4.2 GSM MODEM CONNECTION

Most GSM modems have a *Status* LED. The Wavecom Fastrack Supreme as recommended and previously supplied by DSE has a RED Status LED, operating as follows.

LED State	Description
Off	Modem is not powered.
On Continuous	Not connected to GSM network.
Flashing Slow (approximately once every two seconds)	Connected to GSM network.
Flashing Fast (approximately twice per second)	Connected to GSM network data transmission in progress.

2.10.3 RS485 PORT

RS485 Port 1

Parameter	Description
Server ID	Select the server ID of the DSE module's RS485 port. Every device on the RS485 link must have an individual server ID.
Baud Rate	Select the Baud Rate (speed of communication) of the DSE module's RS485 port. Every device on the RS485 link must have the same Baud Rate. 1200 2400 4800 9600 14400 19200 28800 38400 57600 115200

Advanced

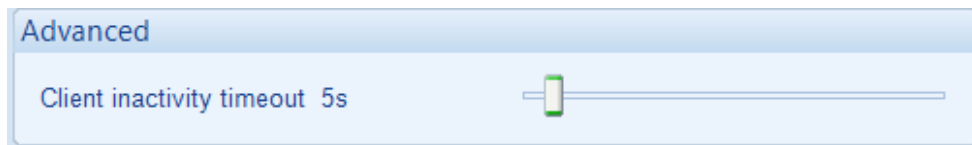

Parameter	Description
Client Inactivity Timeout	Set the time delay between a MODBUS RTU request and the receipt of a response. The module monitors by default the USB port for communications. When activity is detected on the RS485 port, the module monitors the port for further data. If no data activity is detected on the port for the duration of the <i>client Inactivity Timer</i> , it reverts to looking at the USB port. This needs to be set longer than the time between MODBUS polls from the client.

Modbus

The screenshot shows a configuration window titled 'Modbus'. It contains three settings:

- Inter-frame delay:** A numeric input field showing '0 ms' next to a horizontal slider bar.
- Stop Bits:** A dropdown menu currently showing '1'.
- Parity checking:** A dropdown menu currently showing 'No Parity'.

Parameter	Description
Inter-frame Delay	Set the time delay between the DSE module receiving a MODBUS RTU request and the DSE module's response.
Stop Bits	Select the <i>Stop Bits</i> of the RS485 network as required by the MODBUS client device or software. Options are: 1 2
Parity checking	<div style="border: 1px solid black; padding: 5px; margin-bottom: 5px;"> <p>⚠ NOTE: Selecting the <i>Parity</i> is only possible if the <i>Stop Bit</i> is set to 1.</p> </div> <p>Select the required Parity to match the RS485 network as required by the MODBUS client device or software. Options are: <i>Even Parity</i> <i>No Parity</i> <i>Odd Parity</i></p>

2.10.4 REMOTE DISPLAY

NOTE: This feature allows the module to be connected to one DSE25xx MKII remote display module. For further details on the DSE2510 MKII or DSE2520 MKII module operation and configuration, refer to DSE Publication: 057-278 DSE2510 MKII & DSE2520 MKII Operators Manual, and 057-279 DSE2510 MKII & DSE2520MKII Software Manual.

NOTE: DSE25xx MKII and DSE25xx modules cannot be used at the same time. Enabling the DSE25xx MKII through the *Remote Display* in the configuration disables the *2510/2520 Display Module* in the Expansion section. And enabling the *2510/2520 Display Module* in the Expansion section causes the DSE25xx MKII's Remote Display section to be greyed out.

Function	Description
Display Enable	<input type="checkbox"/> = The Remote Display is disabled. <input checked="" type="checkbox"/> = This feature allows the module to be connected to one DSE25xx MKII remote display module.
Link Lost Alarm Action	Select the action for the <i>Link Lost Alarm</i> . Electrical Trip Shutdown Warning This alarm takes action if the remote display DSE25xx MKII module is not detected by the host module.
Connection Port	<p>NOTE: The selected port's Baud Rate is fixed to 115200, the relevant port's server ID is configured in the Communications section.</p> Select the port to be used for the Remote Display.

2.11 SCHEDULER

The section is subdivided into smaller sections.

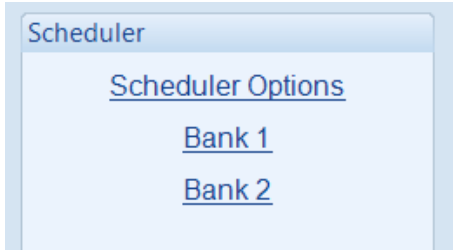

2.11.1 SCHEDULER OPTIONS

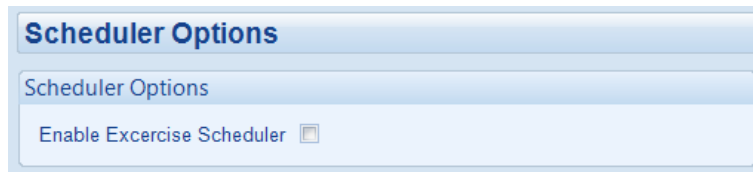

Function	Description
Enable Exercise Scheduler	<input type="checkbox"/> = The scheduler is disabled. <input checked="" type="checkbox"/> = The scheduler is enabled, Bank 1 and Bank 2 become editable.

2.11.2 BANK 1 / BANK 2

Each Bank of the Exercise Scheduler is used to give up to 8 scheduled runs per bank, 16 in total. This run schedule is configurable to repeat every 7 days (weekly) or every 28 days (monthly). The run is *On Load*, *Off Load* or *Auto Start Inhibit*.

Each scheduler bank configured differently either to weekly or monthly based exercises.

Function	Description
Schedule Period	Determines the repeat interval for the scheduled run. Options available are: Weekly: The schedule events occur every week. Monthly: The schedule events occur every month on the week selected.
Week	Specifies the week of the month, on which the scheduled run takes place.
Day	Specifies the day of week, on which the scheduled run takes place.
Run Mode	Determines the loading state mode of the generator when running on schedule. Auto Start Inhibit: The generator is prevented from running in <i>Auto</i> mode. Off Load: The module runs the generator on schedule with the load switch open. On Load: The module runs the generator on schedule and closes the load switch.
Start Time	Determines at what time of day the scheduled run starts.
Duration	Determines the time duration in hours for the scheduled run.
Clear	Resets the values for the Day, Start Time and Duration to defaults.

2.12 MAINTENANCE ALARM

Maintenance Alarm 1

Enable

Description Maintenance Alarm 1

Action Warning

Engine Run Hours 10 hrs

Enable Alarm On Due Date

Maintenance Interval 1 months

There are two ways to reset the maintenance alarm:

- 1) Activate a digital input configured to "Maintenance Reset Alarm".
- 2) Use the SCADA | Maintenance | Maintenance Alarm section of this PC Software.
- 3) Through the Front 'Panel Editor' of the module.

Maintenance Alarm 1 to 3

Function	Description
Enable	<input type="checkbox"/> = The maintenance alarm is disabled. <input checked="" type="checkbox"/> = The maintenance alarm is activated with the configured <i>Action</i> when the engine hours increases more than the <i>Engine Run Hours</i> or when the date increase more than the <i>Maintenance Interval</i> settings.
Description	The text that is displayed on the module's LCD when the maintenance alarm activates.
Action	<div style="border: 2px solid black; padding: 5px;"> <p>NOTE: For details of these, see the section entitled <i>Alarm Types</i> elsewhere in this document.</p> </div> <p>Select the type of alarm required from the list: <i>Electrical Trip</i> <i>Shutdown</i> <i>Warning</i></p>
Engine Run Hours	The value the engine hours must increase by to trigger the maintenance alarm.
Enable Alarm on Due Date	<input type="checkbox"/> = The maintenance alarm only activates on the engine hours increasing. <input checked="" type="checkbox"/> = The maintenance alarm activates on the engine hours increasing or the date increasing, whichever occurs first.
Maintenance Interval	The value the date must increase by to trigger the maintenance alarm.

2.13 CONFIGURABLE CAN INSTRUMENTATION

The *Configurable CAN Instrumentation* section is subdivided into smaller sections. Select the required section with the mouse.

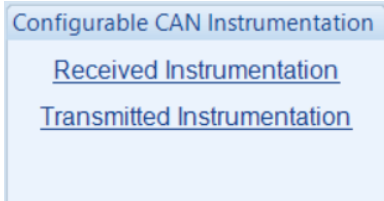

2.13.1 RECEIVED INSTRUMENTATION (1-30)

This feature allows for up to 30 custom engine CAN instrumentation items to be decoded from CAN messages on the connected ECU port.

Received Instrumentation																	
Export		Import															
Instrumentation Configuration																	
Enabled	Module	Message ID			Timeout		Data Structure				Display		Bus Value		Mapped Value		Fn
		View	Description	Bits	CAN ID	Enable	(ms)	Byte	Bit	Length	Signed	D. Places	Suffix	Smallest	Largest	Smallest	
<input checked="" type="checkbox"/>	CAN	Configurable CAN 1	29	0x0	<input checked="" type="checkbox"/>	5000	1	0	1	<input type="checkbox"/>	0		0	1	0	100	Fn
<input checked="" type="checkbox"/>	CAN	Configurable CAN 2	29	0x0	<input checked="" type="checkbox"/>	5000	1	0	1	<input type="checkbox"/>	0		0	1	0	100	Fn
<input checked="" type="checkbox"/>	CAN	Configurable CAN 3	29	0x0	<input checked="" type="checkbox"/>	5000	1	0	1	<input type="checkbox"/>	0		0	1	0	100	Fn
<input type="checkbox"/>	CAN	Configurable CAN 4	29	0x0	<input checked="" type="checkbox"/>	5000	1	0	1	<input type="checkbox"/>	0		0	1	0	100	Fn
<input type="checkbox"/>	CAN	Configurable CAN 5	29	0x0	<input checked="" type="checkbox"/>	5000	1	0	1	<input type="checkbox"/>	0		0	1	0	100	Fn
<input type="checkbox"/>	CAN	Configurable CAN 6	29	0x0	<input checked="" type="checkbox"/>	5000	1	0	1	<input type="checkbox"/>	0		0	1	0	100	Fn
<input type="checkbox"/>	CAN	Configurable CAN 7	29	0x0	<input checked="" type="checkbox"/>	5000	1	0	1	<input type="checkbox"/>	0		0	1	0	100	Fn
<input type="checkbox"/>	CAN	Configurable CAN 8	29	0x0	<input checked="" type="checkbox"/>	5000	1	0	1	<input type="checkbox"/>	0		0	1	0	100	Fn
<input type="checkbox"/>	CAN	Configurable CAN 9	29	0x0	<input checked="" type="checkbox"/>	5000	1	0	1	<input type="checkbox"/>	0		0	1	0	100	Fn
<input type="checkbox"/>	CAN	Configurable CAN 10	29	0x0	<input checked="" type="checkbox"/>	5000	1	0	1	<input type="checkbox"/>	0		0	1	0	100	Fn
<input type="checkbox"/>	CAN	Configurable CAN 11	29	0x0	<input checked="" type="checkbox"/>	5000	1	0	1	<input type="checkbox"/>	0		0	1	0	100	
<input type="checkbox"/>	CAN	Configurable CAN 12	29	0x0	<input checked="" type="checkbox"/>	5000	1	0	1	<input type="checkbox"/>	0		0	1	0	100	
<input type="checkbox"/>	CAN	Configurable CAN 13	29	0x0	<input checked="" type="checkbox"/>	5000	1	0	1	<input type="checkbox"/>	0		0	1	0	100	
<input type="checkbox"/>	CAN	Configurable CAN 14	29	0x0	<input checked="" type="checkbox"/>	5000	1	0	1	<input type="checkbox"/>	0		0	1	0	100	
<input type="checkbox"/>	CAN	Configurable CAN 15	29	0x0	<input checked="" type="checkbox"/>	5000	1	0	1	<input type="checkbox"/>	0		0	1	0	100	
<input type="checkbox"/>	CAN	Configurable CAN 16	29	0x0	<input checked="" type="checkbox"/>	5000	1	0	1	<input type="checkbox"/>	0		0	1	0	100	
<input type="checkbox"/>	CAN	Configurable CAN 17	29	0x0	<input checked="" type="checkbox"/>	5000	1	0	1	<input type="checkbox"/>	0		0	1	0	100	
<input type="checkbox"/>	CAN	Configurable CAN 18	29	0x0	<input checked="" type="checkbox"/>	5000	1	0	1	<input type="checkbox"/>	0		0	1	0	100	
<input type="checkbox"/>	CAN	Configurable CAN 19	29	0x0	<input checked="" type="checkbox"/>	5000	1	0	1	<input type="checkbox"/>	0		0	1	0	100	

Export/Import

This feature is used to import/export the *Configurable CAN Instrumentation* settings.

Parameter	Description
Export	This allows to export the configuration settings of the CAN Received Instrumentation or Transmitted Instrumentation into *.canrx file.
Import	This allows to import an existing configuration settings of the Legacy CAN Export File (*.xml) or Transmitted (*.canrx) file.

2.13.1.1 INSTRUMENT CONFIGURATION

Module

Parameter	Description
Enabled	 NOTE: The CAN instrumentation must already be available on the CAN bus. There is no request for a non-standard instrumentation. <input type="checkbox"/> = The CAN instrumentation is disabled. <input checked="" type="checkbox"/> = The CAN instrumentation is enabled. Reading depends upon the message availability on the bus.
View	The options are as follows: CAN: The value is shown under CAN page on the module display screen. Disabled: The value is not shown on the module display screen. Engine: The value is shown under Engine page on the module display screen.

Message ID

Parameter	Description
Description	Provide a description for the CAN instrumentation. This description is shown in the Scada and module display screen..
Bits	The options are: 29: A 29 bit identifier (extended format) allows a total of 229 (= 536+ million) messages. 11: An 11 bit identifier (standard format) allows a total of 211 (= 2048) different messages.
CAN ID	29-bit CAN Message Identifier to receive. CAN ID must match exactly the full ID of the message to be received in the standard J1939 29-bit (Extended) format.

Timeout

Parameter	Description
Enable	<input type="checkbox"/> = Timeout is disabled. <input checked="" type="checkbox"/> = Timeout is enabled.
(ms)	It indicates how often the messages are expected to be seen on the CAN bus in milliseconds. If no new instrumentation is seen beyond the timeout period, the calculated instrumentation value changes to a 'bad data' sentinel value.

Data Structure

Parameter	Description
Byte	Set the start position Byte.
Bit	Set the start position Bit.
Length (Bits)	Data length 1-32 bits.
Signed	<input type="checkbox"/> = Unsigned value. <input checked="" type="checkbox"/> = Signed value.

Display

 **NOTE: If the received CAN instrument is outside the configured raw values, the module displays sentinel value.**

Parameter	Description
Decimal Places	Display the decimal point. 0 represents 0 scaling factor, 1 represents 0.1 scaling factor, -1 represents 10 multiplier.
Suffix	Unit display (example: m ³ /hr).

Bus Value

Parameter	Description																								
Smallest	This is the smallest value (up to the Largest Bus Value setting) which can be sent over the CAN bus.																								
Largest	<p>This is the largest value (up to the maximum <i>Data Structure-Length</i> setting) which can be sent over the CAN bus.</p> <p>For Example:</p> <p>If the un-signed <i>Data Structure- Length</i> value is 4 then the <i>Largest Bus Value</i> will be 15.</p> <div style="display: flex; justify-content: space-around; align-items: center;"> <div style="border: 1px solid black; border-radius: 50%; padding: 5px; background-color: #e0f0ff;">Data Structure length (un-signed.)</div> <div style="border: 1px solid black; border-radius: 50%; padding: 5px; background-color: #e0f0ff;">Largest Bus Value.</div> </div> <table border="1" style="margin: 10px auto; border-collapse: collapse;"> <thead> <tr> <th colspan="4">Data Structure</th> <th colspan="2">Display</th> <th colspan="2">Bus Value</th> </tr> <tr> <th>Byte</th> <th>Bit</th> <th>Length</th> <th>Signed</th> <th>D. Places</th> <th>Suffix</th> <th>Smallest</th> <th>Largest</th> </tr> </thead> <tbody> <tr> <td>1</td> <td>0</td> <td>4</td> <td><input type="checkbox"/></td> <td>0</td> <td></td> <td>0</td> <td>15</td> </tr> </tbody> </table>	Data Structure				Display		Bus Value		Byte	Bit	Length	Signed	D. Places	Suffix	Smallest	Largest	1	0	4	<input type="checkbox"/>	0		0	15
Data Structure				Display		Bus Value																			
Byte	Bit	Length	Signed	D. Places	Suffix	Smallest	Largest																		
1	0	4	<input type="checkbox"/>	0		0	15																		

Mapped Value

Parameter	Description
Mapped Value Smallest	Details how the <i>Displayed Values</i> relate to the received <i>Bus Values</i> . For example: <i>Bus Value</i> 10 to 100.
Mapped Value Largest	<i>Mapped Value</i> 20 to 200.
	This configures the device to display 20 when the value 10 is received and to display 200 when the value 100 is received. Values in between are linearly interpolated.

Test

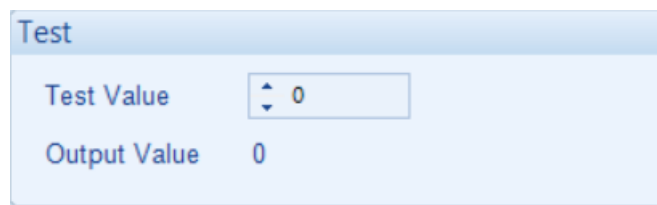

Parameter	Description
Test Raw Value	<p>NOTE: The Test Raw Value is not saved in the configuration, this is only to check the displayed value.</p> <p>This is a test case to check the representation of the <i>Raw Value</i> when they are complicated. <i>Test Raw Value</i> is the value read from the CAN bus before the transformation.</p>
Displayed Value	The <i>Test Raw Value</i> 's represented value as to be shown on the module's screen, or in the Scada.

Function

The Function is only available for the Received Instrumentation (1-30), it allows to configure a User Configured alarm by monitoring the relevant *Configurable CAN Instrumentation*.

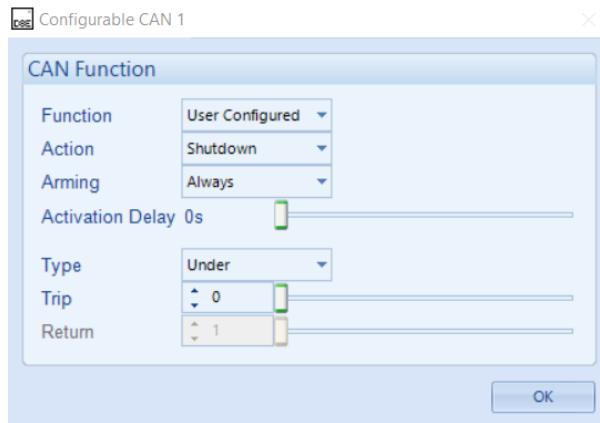

Parameter	Description
Function	<p>Select a digital input function to activate according to the CAN value received.</p> <p>NOTE: Refer to the <i>Digital Inputs</i> section elsewhere in this document for the list of descriptions of the functions list.</p> <p>NOTE: <i>Crank Disconnect</i> function has been added in this list to instruct the module to crank disconnect when the value sent over the CAN line is under or over the configured Trip level.</p>
Action	<p>NOTE: <i>Action</i> is only adjustable when <i>Function</i> is set to <i>User Configured</i>.</p> <p>Select the type of alarm to activate the <i>Function</i> after the <i>Activation Delay</i> time.</p> <p>Electrical Trip Indication Shutdown Warning</p>
Arming	<p>NOTE: <i>Arming</i> is only adjustable when <i>Function</i> is set to <i>User Configured</i>.</p> <p>Select when the <i>Trip</i> level is monitored.</p> <p>Options are as follows: Always: The protection is always active on the controller. This is used to constantly monitor status of the <i>CAN Instrumentation</i>. From Safety On: Active only after the <i>Safety On</i> delay timer. When Stationary: Active only when the engine is not running.</p>
Activation Delay	<p>The amount of time before the module activates the selected <i>Function</i> upon the <i>Configurable CAN Instrumentation</i> reaching the <i>Trip</i> level.</p>
Type	<p>Select the required option to monitor the <i>Configurable CAN Instrumentation</i> when to trip.</p> <p>Over: The <i>Function</i> is active when the <i>Configurable CAN Instrumentation</i> raises above the <i>Trip</i> level for longer than the <i>Activation Delay</i> timer. Under: The <i>Function</i> is active when the <i>Configurable CAN Instrumentation</i> lowers below the <i>Trip</i> level for longer than the <i>Activation Delay</i> timer.</p>
Return	<p>The Function is removed when the <i>Configurable CAN Instrumentation</i> value rises above the <i>Return</i> level if <i>Type</i> is <i>Under</i>. The Function is removed when the <i>Configurable CAN Instrumentation</i> value is reduced below the <i>Return</i> level if <i>Type</i> is <i>Over</i>.</p>

2.13.2 TRANSMITTED INSTRUMENTATION

The module allows transmitting up to 10 instruments over the CANbus on the ECU port by specifying the source address (message ID) of the selected Instrument.

Transmitted Instrumentation

Export Import

Instrumentation Configuration

Enabled	Message ID			Data Structure				Source Value			Bus Value	
	Bits	CAN ID	Rate (ms)	Byte	Bit	Length	Signed	Source	Smallest	Largest	Smallest	Largest
<input checked="" type="checkbox"/>	29	0x1	100	6	3	5	<input checked="" type="checkbox"/>	<Not Used>	0	100	-1	0
<input checked="" type="checkbox"/>	29	0x0	100	1	0	1	<input checked="" type="checkbox"/>	<Not Used>	0	100	-1	0
<input checked="" type="checkbox"/>	29	0x0	100	1	0	1	<input type="checkbox"/>	<Not Used>	0	100	0	1
<input checked="" type="checkbox"/>	29	0x0	100	1	0	1	<input type="checkbox"/>	<Not Used>	0	100	0	1
<input type="checkbox"/>	29	0x0	100	1	0	1	<input type="checkbox"/>	<Not Used>	0	100	0	1
<input type="checkbox"/>	29	0x0	100	1	0	1	<input type="checkbox"/>	<Not Used>	0	100	0	1
<input type="checkbox"/>	29	0x0	100	1	0	1	<input type="checkbox"/>	<Not Used>	0	100	0	1
<input type="checkbox"/>	29	0x0	100	1	0	1	<input type="checkbox"/>	<Not Used>	0	100	0	1
<input type="checkbox"/>	29	0x0	100	1	0	1	<input type="checkbox"/>	<Not Used>	0	100	0	1

Export/Import

This feature is used to import/export the *Configurable CAN Instrumentation* settings.

Parameter	Description
Export	This allows to export the configuration settings of the CAN Received Instrumentation or Transmitted Instrumentation into *.cantx file.
Import	This allows to import an existing configuration settings of the Legacy CAN Export File (*.xml) or Transmitted (*.cantx) file.

2.13.2.1.1 INSTRUMENT CONFIGURATION

Message ID

Parameter	Description
Enabled	<input type="checkbox"/> = The Transmit CAN instrumentation is disabled. <input checked="" type="checkbox"/> = The Transmit CAN instrumentation is enabled.
Bits	The options are: 29: A 29 bit identifier (extended format) allows a total of 229 (= 536+ million) messages. 11: An 11 bit identifier (standard format) allows a total of 211 (= 2048) different messages.
CAN ID	29-bit CAN Message Identifier to transmit CAN ID must match exactly the full ID of the message to be received in the standard J1939 29-bit (Extended) format.
Rate (ms)	The rate at which the <i>CAN Instrument</i> is transmitted over the 'CANbus'.

Data Structure

Parameter	Description
Offset Byte	Set the start position Byte
Offset Bit	Set the start position Bit
Length (Bits)	Data length 1-32 bits
Signed Value	<input type="checkbox"/> = Transmit unsigned value <input checked="" type="checkbox"/> = Transmit signed value

Source Value

Parameter	Description
Source	Select the source of the data to be transmitted over the CANbus. Alarms Control Instrumentation Status See section entitled <i>Output Sources</i> for details of all available functions.
Smallest Source Value	The smallest instrument value before being sent over the CAN bus.
Largest Source Value	The largest instrument value before being sent over the CAN bus.

Bus Value

Parameter	Description
Smallest	The smallest data sent over the CAN bus before the transformations (decimal places).
Largest	The largest data sent over the CAN bus before the transformations (decimal places).

Test

Test

Test Value

Output Value 0

Parameter	Description
Test Raw Value	<p>▲ NOTE: The Test Raw Value is not saved in the configuration, this is only to check the displayed value.</p> <p>This is a test case to check the representation of the <i>Raw Value</i> when they are complicated. <i>Test Raw Value</i> is the value read from the CAN bus before the transformation.</p>
Displayed Value	The <i>Test Raw Value</i> 's represented value as to be shown on the module's screen, or in the Scada.

2.14 ALTERNATIVE CONFIGURATIONS

An Alternative Configuration is provided to allow the system designer to cater for different AC requirements utilising the same generator system. Typically this feature is used by Rental Set Manufacturers where the set is capable of being operated at (for instance) 120V 50Hz and 240V 50Hz using a selector switch.

The Alternative Configuration is selected using either:

- Configuration Suite Software (Selection for 'Default Configuration')
- Module Front Panel Editor.
- Via external signal to the module input configured to "Alternative Configuration" select.

Select the required section with the mouse.

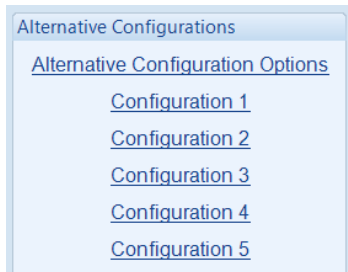

2.14.1 ALTERNATIVE CONFIGURATION OPTIONS

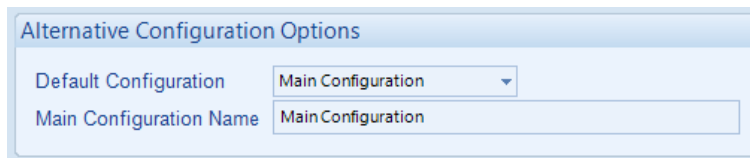

Parameter	Description
Default Configuration	Select the 'default' configuration that is used when there is no instruction to use an 'alternative configuration'.
Main Configuration Name	Free entry box to allow the user to give the Main Configuration name. This is shown on the module's display when the configuration is selected.

2.14.2 ALTERNATIVE CONFIGURATION 1 TO 5

The Alternative Configurations Editor allows for editing of the parameters that are to be changed when an Alternative Configuration is selected.

Select the required section with the mouse.

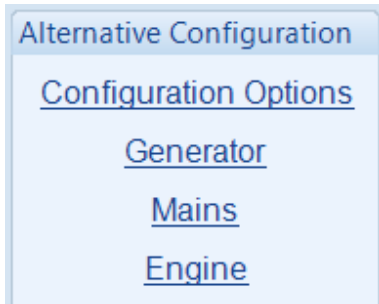

2.14.2.1 CONFIGURATION OPTIONS

Enable Alternative Configuration

The image shows a form titled 'Configuration Options'. It has two main sections: 'Enable Configuration' and 'Instrumentation Suppression'. In the 'Enable Configuration' section, there is a checked checkbox for 'Enable Configuration' and a text input field for 'Configuration Name'. In the 'Instrumentation Suppression' section, there is a text label 'Suppress the following instrumentation on the module screen and SCADA, and disable PhPh alarms' and two checkboxes: 'Generator PhPh Voltage' and 'Mains PhPh Voltage', both of which are currently unchecked.

Parameter	Description
Enable Configuration	<input type="checkbox"/> = <i>Alternative Configuration</i> is disabled. <input checked="" type="checkbox"/> = <i>Alternative Configuration</i> is enabled. The configuration is enabled by changing the <i>Default Configuration</i> , activating a digital input or through the module's <i>Front Panel Editor</i> .

2.14.2.2 GENERATOR / MAINS / ENGINE

Alternative configuration options contain a subset of the main configuration. The adjustable parameters are not discussed here as they are identical to the main configuration options:

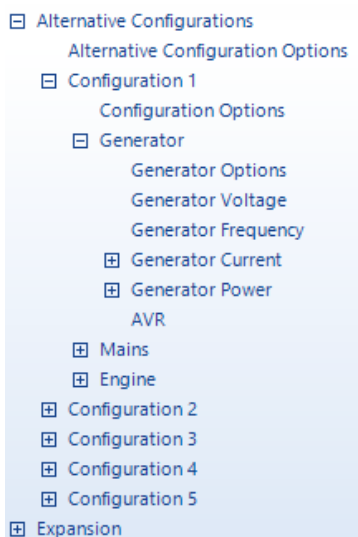

Configuration menus for the *Alternative Configuration*. For information about the configuration items within this section, refer to their description in the 'main' configuration.

2.15 EXPANSION

The *Expansion* page is subdivided into smaller sections. Select the required section with the mouse.

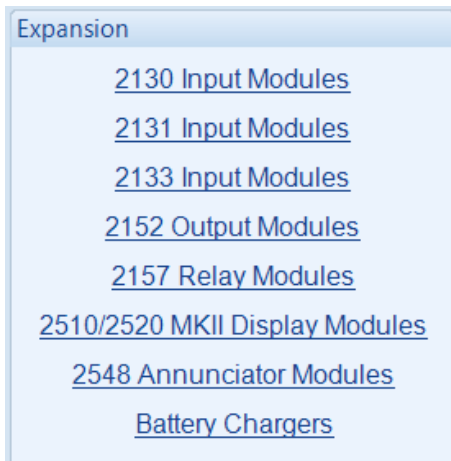

See overleaf for description of the different expansion modules.

2.15.1 2130 INPUT MODULES

Select the DSENet ID of the input expansion to be configured. The ID of the expansion module is set by rotary decimal switch accessible under the removable cover of the device.

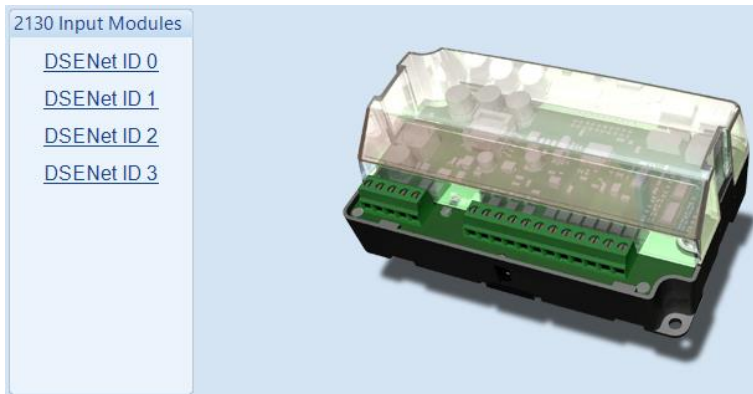

The following options are then shown:

2130 Expansion Enable

2130 Expansion Enable

Expansion Enabled

Link Lost Alarm Action Shutdown ▼

Parameter	Description
Expansion Enabled	<input type="checkbox"/> = The expansion module with the selected ID is not enabled. <input checked="" type="checkbox"/> = The expansion module with the selected ID is enabled. If the expansion module is not connected / detected by the module, the module generates an <i>Exp. Unit Failure</i> alarm with the configured <i>Link Lost Alarm Action</i> severity.

2130 Expansion Inputs

The *Expansion Unit* page is then subdivided into smaller sections. Select the required section with the mouse.

2130 Expansion Inputs

[Analogue Input Configuration](#)
[Analogue Inputs](#)
[Digital Inputs](#)

2.15.1.1 ANALOGUE INPUT CONFIGURATION

Input Configuration

Parameter	Description
Analogue Input E to H	Select what the analogue input is to be used for: Not Used: The analogue input is disabled Digital Input: Configured on the 2130/Digital Inputs pages Flexible Analogue: Configured on the 2130/Analogue Inputs pages

2.15.1.2 ANALOGUE INPUTS

NOTE: An analogue input is only configurable as a flexible sensor if it has been configured as Flexible Analogue, refer to section entitled *Analogue Input Configuration* elsewhere in this document for further details.

Sensor Description

Parameter	Description
Sensor Name	Enter the <i>Sensor Name</i> , this text is shown on the module display when viewing the instrument.

Input Type

Parameter	Description
Input Type	Select the sensor type and curve from a pre-defined list or create a user-defined curve. Available sensor types: Resistive: for sensors with maximum range of 0 Ω to 480 Ω Available parameters to be measured: Pressure: The input is configured as a pressure sensor Percentage: The input is configured as a percentage sensor Temperature: The input is configured as a temperature sensor

Parameter descriptions are continued overleaf...

Sensor Alarms

Parameter	Description
Alarm Arming	<p>NOTE: For details of these, see the section entitled <i>Alarm Arming</i> elsewhere in this document.</p> <p>Select when the alarm generated by the analogue input becomes active: Always From Safety On From Starting</p>
Low Alarm Enable	<p><input type="checkbox"/> = The Alarm is disabled. <input checked="" type="checkbox"/> = The <i>Low Alarm</i> activates when the measured quantity drops below the <i>Low Alarm</i> setting.</p>
Low Alarm Action	<p>NOTE: For details of these, see the section entitled <i>Alarm Types</i> elsewhere in this document.</p> <p>Select the type of alarm required from the list: Electrical Trip Shutdown</p>
Low Pre-Alarm Enable	<p><input type="checkbox"/> = The Pre-Alarm is disabled. <input checked="" type="checkbox"/> = The <i>Low Pre-Alarm</i> is active when the measured quantity drops below the <i>Low Pre-Alarm Trip</i> setting. The <i>Low Pre-Alarm</i> is automatically reset when the measured quantity rises above the configured <i>Low Pre-Alarm Return</i> level.</p>
Low Alarm String	<p>The text that is displayed on the module's LCD when the <i>Low Alarm</i> or <i>Low Pre-Alarm</i> activates.</p>

Parameter descriptions are continued overleaf...

Parameter	Description
High Pre-Alarm Enable	<input type="checkbox"/> = The Pre-Alarm is disabled. <input checked="" type="checkbox"/> = The <i>High Pre-Alarm</i> is active when the measured quantity rises above the <i>High Pre-Alarm Trip</i> setting. The <i>High Pre-Alarm</i> is automatically reset when the measured quantity falls below the configured <i>High Pre-Alarm Return</i> level.
High Alarm Enable	<input type="checkbox"/> = The Alarm is disabled. <input checked="" type="checkbox"/> = The <i>High Alarm</i> is active when the measured quantity rises above the <i>High Alarm</i> setting.
High Alarm Action	<div style="border: 1px solid black; padding: 5px; margin-bottom: 5px;">  NOTE: For details of these, see the section entitled <i>Alarm Types</i> elsewhere in this document. </div> <p>Select the type of alarm required from the list: <i>Electrical Trip</i> <i>Shutdown</i></p>
High Alarm String	The text that is displayed on the module's LCD when the <i>High Alarm</i> or <i>High Pre-Alarm</i> activates.

2.15.1.3 DIGITAL INPUTS

The *Digital Inputs* section is subdivided into smaller sections. Select the required section with the mouse.

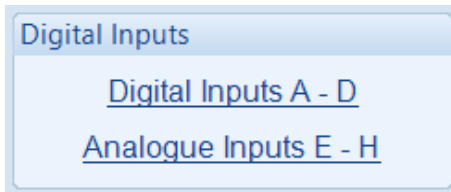

2.15.1.3.1 DIGITAL INPUTS

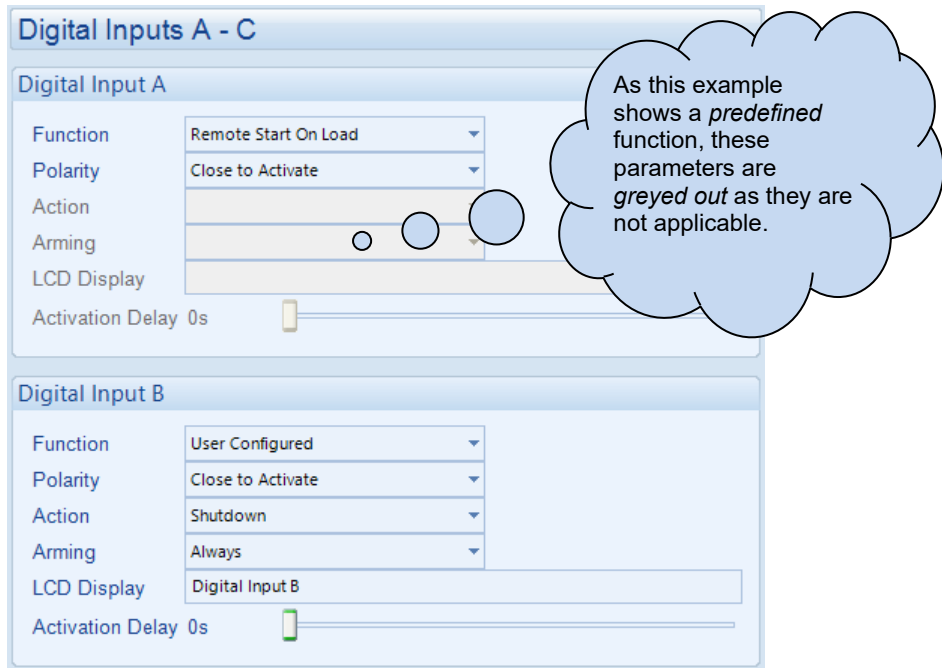

Parameter	Description
Function	Select the input function to activate when the relevant terminal is energised. See section entitled <i>Input Functions</i> for details of all available functions
Polarity	Select the digital input polarity: Close to Activate: the input function is activated when the relevant terminal is connected. Open to Activate: the input function is activated when the relevant terminal is disconnected.
Action	<div style="border: 1px solid black; padding: 5px;"> <p>NOTE: For details of these, see the section entitled <i>Alarm Types</i> elsewhere in this document.</p> </div> <p>Select the type of alarm required from the list: Electrical Trip Indication Shutdown Warning</p>
Arming	<div style="border: 1px solid black; padding: 5px;"> <p>NOTE: For details of these, see the section entitled <i>Alarm Arming</i> elsewhere in this document.</p> </div> <p>Select when the input becomes active: Active from Mains Parallel Always From Safety On From Starting Never</p>
LCD Display	The text that is displayed on the module's LCD when the input activates and generates an alarm.
Activation Delay	This is used to give a delay on acceptance of the input. Useful for liquid level switches or to mask short term operations of the external switch device.

2.15.1.3.2 ANALOGUE INPUTS

NOTE: An analogue input is only configurable as a digital input if it has been configured as Digital Input, refer to section entitled *Analogue Input Configuration* elsewhere in this document for further details.

Analogue Inputs E - H

Analogue Input E (Digital)

Function	User Configured
Polarity	Close to Activate
Action	Warning
Arming	Always
LCD Display	2130 ID0 Analogue E (Digital)
Activation Delay 0s	<input type="range"/>

Analogue Input F (Digital)

The Analogue Input is not configured as a Digital Input
To reconfigure, use the 'Analogue Input Configuration' page

Parameter	Description
Function	Select the input function to activate when the relevant terminal is energised. See section entitled <i>Input Functions</i> for details of all available functions
Polarity	Select the digital input polarity: Close to Activate: the input function is activated when the relevant terminal is connected. Open to Activate: the input function is activated when the relevant terminal is disconnected.
Action	<p>NOTE: For details of these, see the section entitled <i>Alarm Types</i> elsewhere in this document.</p> <p>Select the type of alarm required from the list: Electrical Trip Indication Shutdown Warning</p>
Arming	<p>NOTE: For details of these, see the section entitled <i>Alarm Arming</i> elsewhere in this document.</p> <p>Select when the input becomes active: Active from Mains Parallel Always From Safety On From Starting Never</p>
LCD Display	The text that is displayed on the module's LCD when the input activates and generates an alarm.
Activation Delay	This is used to give a delay on acceptance of the input. Useful for liquid level switches or to mask short term operations of the external switch device.

2.15.2 DSE2131 INPUT MODULES

Select the DSENet ID of the input expansion to be configured. The ID of the expansion module is set by rotary decimal switch accessible under the removable cover of the device.



The following options are then shown:

2131 Expansion Enable

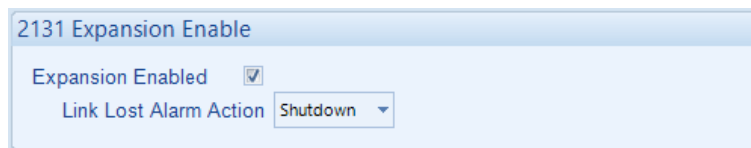

Parameter	Description
Expansion Enabled	<p><input type="checkbox"/> = The expansion module with the selected ID is not enabled.</p> <p><input checked="" type="checkbox"/> = The expansion module with the selected ID is enabled. If the expansion module is not connected / detected by the module, the module generates an <i>Exp. Unit Failure</i> alarm with the configured <i>Link Lost Alarm Action</i> severity.</p>

2131 Expansion Inputs

The *Expansion Unit* page is then subdivided into smaller sections. Select the required section with the mouse.

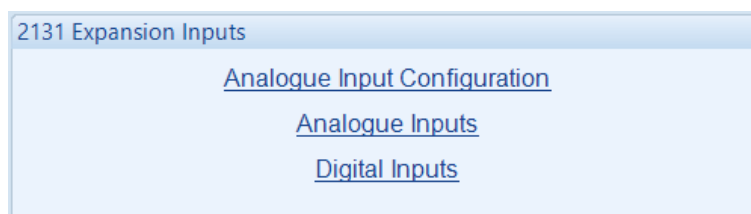

2.15.2.1 ANALOGUE INPUT CONFIGURATION

Input Configuration

Analogue Input A	Flexible Analogue ▾
Analogue Input B	Flexible Analogue ▾
Analogue Input C	Not Used ▾
Analogue Input D	Flexible Analogue ▾
Analogue Input E	Digital Input ▾
Analogue Input F	Digital Input ▾
Analogue Input G	Digital Input ▾
Analogue Input H	Flexible Analogue ▾
Analogue Input I	Digital Input ▾
Analogue Input J	Not Used ▾

Input Configuration

Parameter	Description
Analogue Input A to J	Select what the analogue input is to be used for: Not Used: The analogue input is disabled Digital Input: Configured on the <i>2131/Digital Inputs</i> pages Flexible Analogue: Configured on the <i>2131/Analogue Inputs</i> pages

2.15.2.2 ANALOGUE INPUTS

NOTE: An analogue input is only configurable as a flexible sensor if it has been configured as Flexible Analogue, refer to section entitled *Analogue Input Configuration* elsewhere in this document for further details.

Sensor Description

Sensor Description

Sensor Name

Parameter	Description
Sensor Name	Enter the <i>Sensor Name</i> , this text is shown on the module display when viewing the instrument.

Input Type

Input Type

VDO Ohm range (10-180)

Parameter	Description
Input Type	<p>Select the sensor type and curve from a pre-defined list or create a user-defined curve.</p> <p>Available sensor types:</p> <p>Current: for sensors with maximum range of 0 mA to 20 mA</p> <p>Resistive: for sensors with maximum range of 0 Ω to 1920 Ω</p> <p>Voltage: for sensors with maximum range of 0 V to 10 V</p> <p>Available parameters to be measured:</p> <p>Pressure: The input is configured as a pressure sensor</p> <p>Percentage: The input is configured as a percentage sensor</p> <p>Temperature: The input is configured as a temperature sensor</p>

Parameter descriptions are continued overleaf...

Sensor Alarms

Parameter	Description
Alarm Arming	<p>NOTE: For details of these, see the section entitled <i>Alarm Arming</i> elsewhere in this document.</p> <p>Select when the alarm generated by the analogue input becomes active: Always From Safety On From Starting</p>
Low Alarm Enable	<p><input type="checkbox"/> = The Alarm is disabled. <input checked="" type="checkbox"/> = The <i>Low Alarm</i> activates when the measured quantity drops below the <i>Low Alarm</i> setting.</p>
Low Alarm Action	<p>NOTE: For details of these, see the section entitled <i>Alarm Types</i> elsewhere in this document.</p> <p>Select the type of alarm required from the list: Electrical Trip Shutdown</p>
Low Pre-Alarm Enable	<p><input type="checkbox"/> = The Pre-Alarm is disabled. <input checked="" type="checkbox"/> = The <i>Low Pre-Alarm</i> is active when the measured quantity drops below the <i>Low Pre-Alarm Trip</i> setting. The <i>Low Pre-Alarm</i> is automatically reset when the measured quantity rises above the configured <i>Low Pre-Alarm Return</i> level.</p>
Low Alarm String	<p>The text that is displayed on the module's LCD when the <i>Low Alarm</i> or <i>Low Pre-Alarm</i> activates.</p>

Parameter descriptions are continued overleaf...

Parameter	Description
High Pre-Alarm Enable	<input type="checkbox"/> = The Pre-Alarm is disabled. <input checked="" type="checkbox"/> = The <i>High Pre-Alarm</i> is active when the measured quantity rises above the <i>High Pre-Alarm Trip</i> setting. The <i>High Pre-Alarm</i> is automatically reset when the measured quantity falls below the configured <i>High Pre-Alarm Return</i> level.
High Alarm Enable	<input type="checkbox"/> = The Alarm is disabled. <input checked="" type="checkbox"/> = The <i>High Alarm</i> is active when the measured quantity rises above the <i>High Alarm</i> setting.
High Alarm Action	<div style="border: 1px solid black; padding: 5px; margin-bottom: 5px;">  NOTE: For details of these, see the section entitled <i>Alarm Types</i> elsewhere in this document. </div> <p>Select the type of alarm required from the list: <i>Electrical Trip</i> <i>Shutdown</i></p>
High Alarm String	The text that is displayed on the module's LCD when the <i>High Alarm</i> or <i>High Pre-Alarm</i> activates.

2.15.2.3 DIGITAL INPUTS

NOTE: An analogue input is only configurable as a digital input if it has been configured as Digital Input, refer to section entitled *Analogue Input Configuration* elsewhere in this document for further details.

Analogue Inputs A - C

Analogue Input A (Digital)

Function	Alarm Mute
Polarity	Close to Activate
Action	
Arming	
LCD Display	2131 ID0 Flexible Sensor A
Activation Delay	0s

Analogue Input B (Digital)



Function	User Configured
Polarity	Close to Activate
Action	Warning
Arming	Always
LCD Display	2131 ID0 Flexible Sensor B
Activation Delay	0s

Analogue Input C (Digital)

The Analogue Input is not configured as a Digital Input
To reconfigure, use the 'Analogue Input Configuration' page

As this example shows a predefined function, these parameters are greyed out as they are not applicable.

Parameter descriptions are overleaf...

Parameter	Description
Function	Select the input function to activate when the relevant terminal is energised. See section entitled <i>Input Functions</i> for details of all available functions
Polarity	Select the digital input polarity: Close to Activate: The input function is activated when the relevant terminal is connected. Open to Activate: The input function is activated when the relevant terminal is disconnected.
Action	<div style="border: 1px solid black; padding: 5px;">  NOTE: For details of these, see the section entitled <i>Alarm Types</i> elsewhere in this document. </div> Select the type of alarm required from the list: Electrical Trip Indication Shutdown Warning
Arming	<div style="border: 1px solid black; padding: 5px;">  NOTE: For details of these, see the section entitled <i>Alarm Arming</i> elsewhere in this document. </div> Select when the input becomes active: Active from Mains Parallel Always From Safety On From Starting Never
LCD Display	The text that is displayed on the module's LCD when the input activates and generates an alarm.
Activation Delay	This is used to give a delay on acceptance of the input. Useful for liquid level switches or to mask short term operations of the external switch device.

2.15.3 DSE2133 INPUT MODULES

Select the DSENet ID of the input expansion to be configured. The ID of the expansion module is set by rotary decimal switch accessible under the removable cover of the device.



The following options are then shown:

2133 Expansion Enable

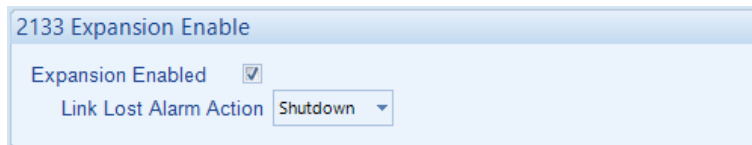

Parameter	Description
Expansion Enabled	<input type="checkbox"/> = The expansion module with the selected ID is not enabled. <input checked="" type="checkbox"/> = The expansion module with the selected ID is enabled. If the expansion module is not connected / detected by the module, the module generates an <i>Exp. Unit Failure</i> alarm with the configured <i>Link Lost Alarm Action</i> severity.

2133 Expansion Inputs

The *Expansion Unit* page is then subdivided into smaller sections. Select the required section with the mouse.

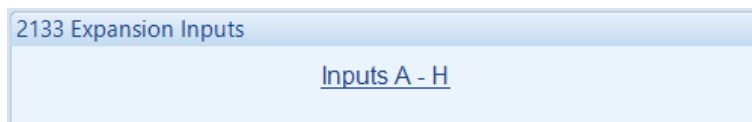

2.15.3.1 ANALOGUE INPUTS

NOTE: An analogue input is only configurable as a flexible sensor if it has been configured as Flexible Analogue, refer to section entitled *Analogue Input Configuration* elsewhere in this document for further details.

Sensor Description

Sensor Description

Sensor Name

Parameter	Description
Sensor Name	Enter the <i>Sensor Name</i> , this text is shown on the module display when viewing the instrument.

Input Type

Input Type

Parameter	Description
Input Type	Select the sensor type from the pre-defined list: 2 Wire PT100 3 Wire PT100 <i>Type J (Thermocouple)</i> <i>Type K (Thermocouple)</i>

Parameter descriptions are continued overleaf...

Sensor Alarms

Parameter	Description
Alarm Arming	<p>NOTE: For details of these, see the section entitled <i>Alarm Arming</i> elsewhere in this document.</p> <p>Select when the alarm generated by the analogue input becomes active: Always From Safety On From Starting</p>
Low Alarm Enable	<p><input type="checkbox"/> = The Alarm is disabled. <input checked="" type="checkbox"/> = The <i>Low Alarm</i> activates when the measured quantity drops below the <i>Low Alarm</i> setting.</p>
Low Alarm Action	<p>NOTE: For details of these, see the section entitled <i>Alarm Types</i> elsewhere in this document.</p> <p>Select the type of alarm required from the list: Electrical Trip Shutdown</p>
Low Pre-Alarm Enable	<p><input type="checkbox"/> = The Pre-Alarm is disabled. <input checked="" type="checkbox"/> = The <i>Low Pre-Alarm</i> is active when the measured quantity drops below the <i>Low Pre-Alarm Trip</i> setting. The <i>Low Pre-Alarm</i> is automatically reset when the measured quantity rises above the configured <i>Low Pre-Alarm Return</i> level.</p>
Low Alarm String	The text that is displayed on the module's LCD when the <i>Low Alarm</i> or <i>Low Pre-Alarm</i> activates.

Parameter descriptions are continued overleaf...

Parameter	Description
High Pre-Alarm Enable	<input type="checkbox"/> = The Pre-Alarm is disabled. <input checked="" type="checkbox"/> = The <i>High Pre-Alarm</i> is active when the measured quantity rises above the <i>High Pre-Alarm Trip</i> setting. The <i>High Pre-Alarm</i> is automatically reset when the measured quantity falls below the configured <i>High Pre-Alarm Return</i> level.
High Alarm Enable	<input type="checkbox"/> = The Alarm is disabled. <input checked="" type="checkbox"/> = The <i>High Alarm</i> is active when the measured quantity rises above the <i>High Alarm</i> setting.
High Alarm Action	<div style="border: 1px solid black; padding: 5px; margin-bottom: 5px;">  NOTE: For details of these, see the section entitled <i>Alarm Types</i> elsewhere in this document. </div> <p>Select the type of alarm required from the list: <i>Electrical Trip</i> <i>Shutdown</i></p>
High Alarm String	The text that is displayed on the module's LCD when the <i>High Alarm</i> or <i>High Pre-Alarm</i> activates.

2.15.4 DSE2152 OUTPUT MODULES

Select the DSENet ID of the output expansion to be configured. The ID of the expansion input module is set by rotary decimal switch accessible under the removable cover of the device.

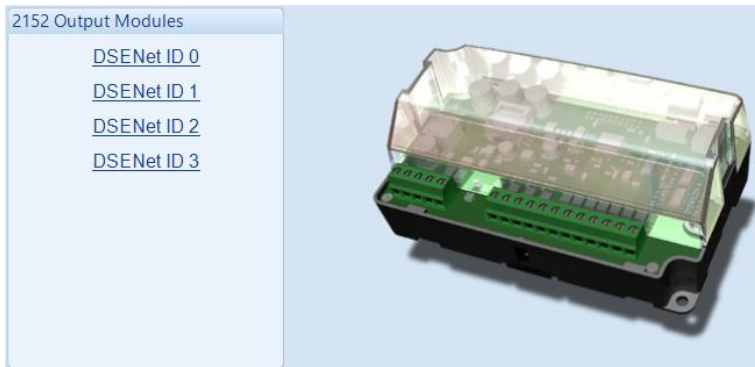

The following options are then shown:

2152 Expansion Enable

2152 Expansion Enable

Expansion Enabled

Link Lost Alarm Action Shutdown ▾

Parameter	Description
Expansion Enabled	<input type="checkbox"/> = The expansion module with the selected ID is not enabled. <input checked="" type="checkbox"/> = The expansion module with the selected ID is enabled. If the expansion module is not connected / detected by the module, the module generates an <i>Exp. Unit Failure</i> alarm with the configured <i>Link Lost Alarm Action</i> severity.

2152 Expansion Outputs

The *Expansion Unit* page is then subdivided into smaller sections. Select the required section with the mouse.

2152 Expansion Outputs

[Outputs A - F](#)

2.15.4.1 ANALOGUE OUTPUTS

Analogue Output A

Output Configuration

Output Type

Source	Curve	
Generator Power Total ▾	0kW to 100kW = 0V to 10V ▾	<input type="button" value="Edit..."/>

Output Configuration

Output Configuration

Parameter	Description
Output Name	Enter the <i>Output Name</i> , this text is shown on in the SCADA section when viewing the output.

Output Type

Output Type

Source	Curve	
Generator Power Total ▾	0kW to 100kW = 0V to 10V ▾	<input type="button" value="Edit..."/>

Click to edit the 'output curve'. See section entitled *Editing the Output Curve*.

Parameter	Description
Source	Select the parameter that is to be mapped to the analogue output.
Curve	Select the output type and curve from a pre-defined list or create a user-defined curve Current: for sensors with maximum range of 0 mA to 20 mA Voltage: for sensors with maximum range of 0 V to 10 V

2.15.4.2 CREATING / EDITING THE OUTPUT CURVE

While the *DSE Configuration Suite* holds specifications for the most used output ranges, occasionally it is required that the expansion module's output be connected to a nonstandard device. To aid this process, a curve editor is provided.

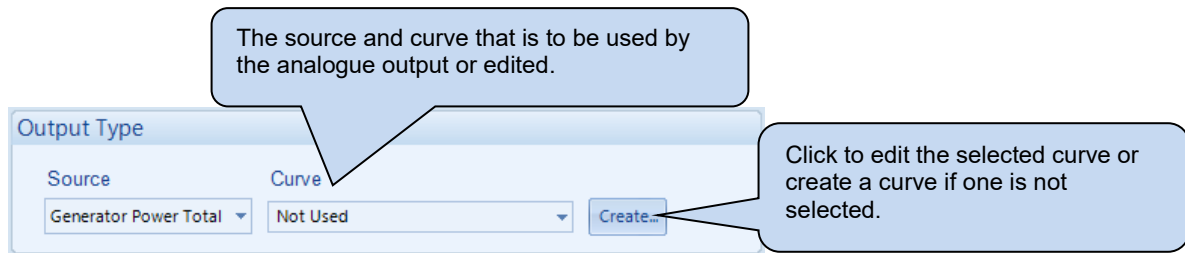

When creating a new sensor curve the measurement quantity and measured parameter are required.

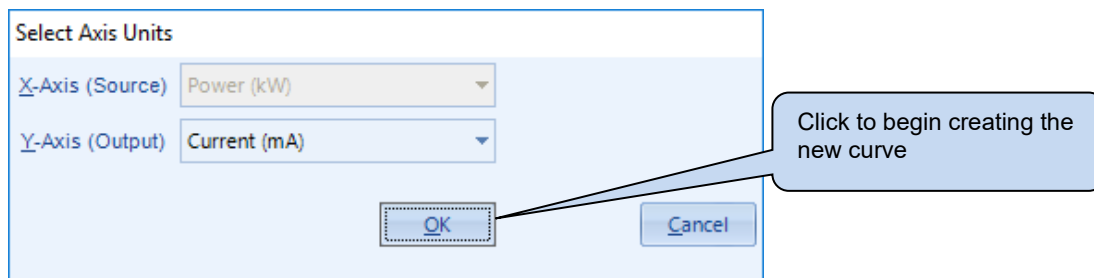

Parameter	Description
Y-Axis (Source)	The parameter measured by the DSE module that is to be mapped to the output.
X-Axis (Output)	Select the electrical quantity that the sensor outputs. Current (mA): For an output current within a range 0 mA to 20 mA Voltage (Volt): For an output voltage within a range of 0 V to 10 V

Curve creation / editor descriptions are continued overleaf...

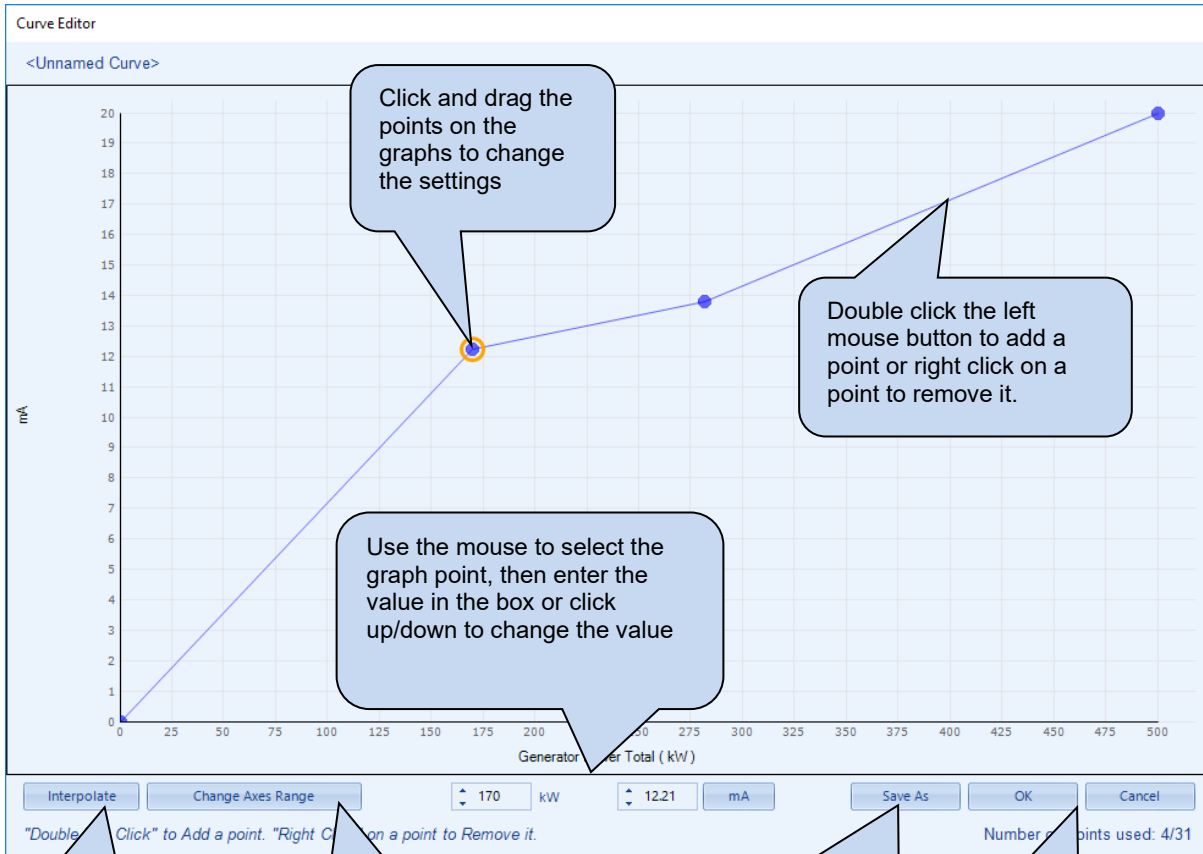

Click *Interpolate* then select two points as prompted to draw a straight line between them.

Click to change the range of the X and Y Axes of the graph and the level of open circuit detection

Click SAVE AS, a prompt to name the curve...

New Curve Name

Enter a name for the new curve

OK Cancel

Click OK to save the curve.

Any saved curves become selectable in the *Output Type* selection list.

Click OK to accept the changes or CANCEL to ignore and lose the changes.

Hint: Deleting, renaming or editing custom curves that have been added is performed in the main menu, select *Tools | Curve Manager*.

2.15.5 DSE2157 RELAY MODULES

Select the DSENet ID of the output expansion to be configured. The ID of the expansion module is set by rotary decimal switch accessible under the removable cover of the device.

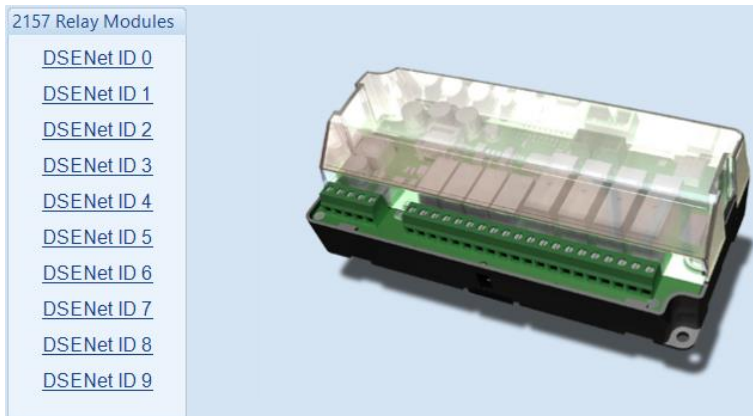

The following options are then shown:

2152 Expansion Enable

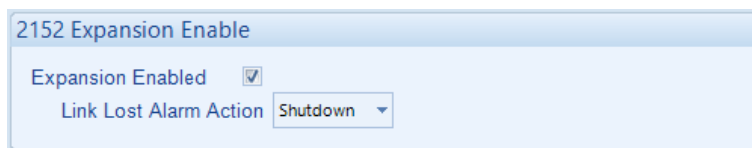

Parameter	Description
Expansion Enabled	<input type="checkbox"/> = The expansion module with the selected ID is not enabled. <input checked="" type="checkbox"/> = The expansion module with the selected ID is enabled. If the expansion module is not connected / detected by the module, the module generates an <i>Exp. Unit Failure</i> alarm with the configured <i>Link Lost Alarm Action</i> severity.

Relay Outputs (Normally Open / Changeover)

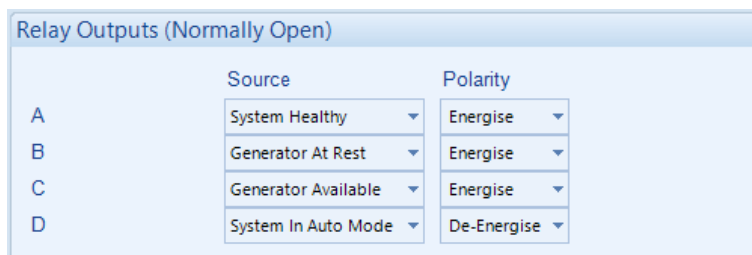

Parameter	Description
Source	Select the output source to control the state of the output See section entitled <i>Output Sources</i> for details of all available functions.
Polarity	Select the digital input polarity: Energise: When the output source is true, the output activates. De-Energise: When the output source is true, the output deactivates.

2.15.6 2510/2520 DISPLAY MODULE

Available on module version 1.x.x, 2.x.x, and 4.x.x.

NOTE: DSE25xx and DSE25xx MKII modules cannot be used at the same time. Enabling the DSE25xx MKII through the *Remote Display* in the configuration disables the *2510/2520 Display Module* in the Expansion section. And enabling the *2510/2520 Display Module* in the Expansion section causes the DSE25xx MKII's *Remote Display* section to be greyed out.

Select the DSENet ID of the Display expansion you wish to configure.



The following is then shown:

DSENet ID 0

2510/2520 Expansion Enable

Expansion Enabled

Link Lost Alarm Action Shutdown

Control Buttons

Control Buttons Enable

Sounder Configuration

Sounder Enable

Follow main unit

Auto Mute Timer Enable

Auto Mute Timer 1m

= The display is for instrumentation only – the mode change buttons are disabled.

= The display acts as a complete mimic/control of the host module.

= If the *mute / lamp test* button is pressed, other DSE2548 modules and the host module will not respond to this.

= If the *mute / lamp test* button is pressed, other DSE2548 modules configured to *Follow main unit* and the host module will also lamp test / mute their alarm and vice-versa.

= *Auto Mute* is disabled.

= The internal sounder will sound for the duration of the *Auto Mute Timer* after which it will automatically stop. Pressing the *MUTE* button during the timer will also silence the sounder.

Click to enable or disable the option. The relevant values below will appear *greyed out* if the alarm is disabled.

Select the alarm type of the *link lost alarm*. This alarm will take action if the expansion module is not detected by the host module.

Enable or disable the expansion module's internal sounder.

2.15.7 2510/2520 MKII DISPLAY MODULES

DSE25xx MKII Display Module option in the Expansion section allows to add two 25xxMKII Remote Display modules at the same time, one being added from the Communications section and the other from the Expansion. This is only available on module version 5.x.x and later.

NOTE: Enabling the DSE25xx MKII from the Expansion section reduces the total number of the expansion units from twenty down to five expansion modules in total, with only a single Battery Charger unit.



The following is then shown:

DSENet ID 0

2510/2520 MKII Display Enable

Expansion Enabled

Link Lost Alarm Action Shutdown

Control Buttons

Control Buttons Enable

Sounder Configuration

Sounder Enable

Follow main unit

Auto Mute Timer Enable

Auto Mute Timer 1m

= The display is for instrumentation only – the mode change buttons are disabled.
 = The display acts as a complete mimic/control of the host module.

= If the *mute / lamp test* button is pressed, other DSE2548 modules and the host module will not respond to this.
 = If the *mute / lamp test* button is pressed, other DSE2548 modules configured to *Follow main unit* and the host module will also lamp test / mute their alarm and vice-versa.

= *Auto Mute* is disabled.
 = The internal sounder will sound for the duration of the *Auto Mute Timer* after which it will automatically stop. Pressing the *MUTE* button during the timer will also silence the sounder.

2.15.8 2548 ANNUNCIATOR MODULES

Select the DSENet ID of the LED expansion to be configured. The ID of the expansion input module is set by rotary decimal switch accessible on the rear of the device.

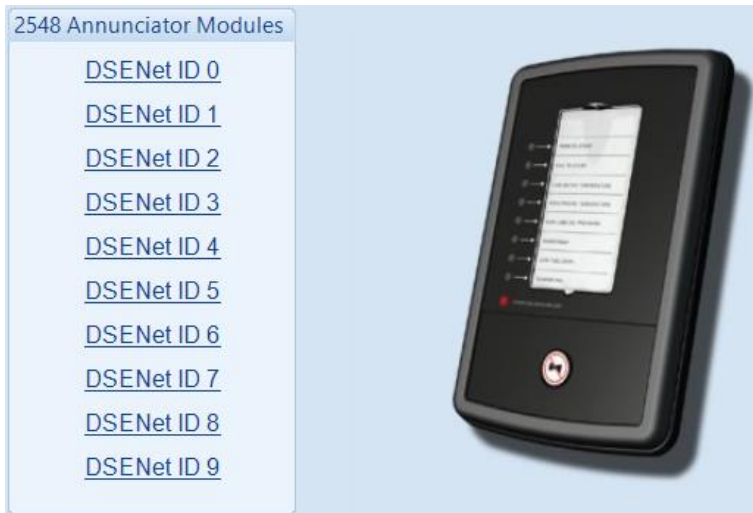

The following options are then shown:

2548 Expansion Enable

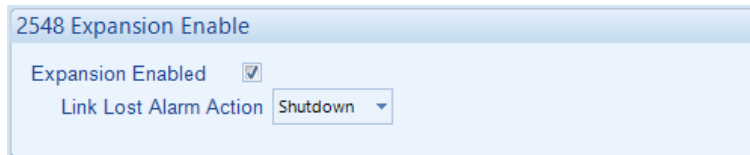

Parameter	Description
Expansion Enabled	<input type="checkbox"/> = The expansion module with the selected ID is not enabled. <input checked="" type="checkbox"/> = The expansion module with the selected ID is enabled. If the expansion module is not connected / detected by the module, the module generates an <i>Exp. Unit Failure</i> alarm with the configured <i>Link Lost Alarm Action</i> severity.

Sounder Configuration

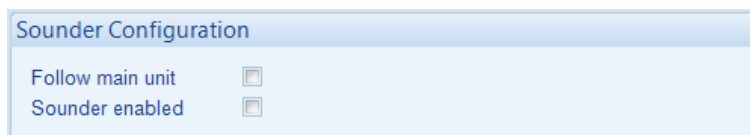

Parameter	Description
Follow Main Unit	<input type="checkbox"/> = If the <i>mute / lamp test</i> button is pressed, other DSE2548 modules and the host module does not respond to this. <input checked="" type="checkbox"/> = If the <i>mute / lamp test</i> button is pressed, other DSE2548 modules configured to <i>Follow main unit</i> and the host module also lamp test / mute their alarm and vice-versa.
Sounder Enabled	<input type="checkbox"/> = The DSE2548 internal sounder does not annunciate on a fault condition becoming active. <input checked="" type="checkbox"/> = The DSE2548 internal sounder annunciates on a fault condition becoming active.

Parameter descriptions are continued overleaf...

LED Indicators

LED Indicators

A	System In Auto Mode ▾	Unlit ▾
B	Generator Load Inhibited ▾	Lit ▾
C	Combined Remote Start Request ▾	Lit ▾
D	Common Alarm ▾	Lit ▾
E	Not Used ▾	Lit ▾
F	Not Used ▾	Lit ▾
G	Not Used ▾	Lit ▾
H	Not Used ▾	Lit ▾

Annunciator Insert Card

Parameter	Description
Source	Select the output source to control the state of the output. See section entitled <i>Output Sources</i> for details of all available functions.
Polarity	Select the digital input polarity: Energise: When the output source is true, the output activates. De-Energise: When the output source is true, the output deactivates.
Annunciator Insert Card	Allows the user to create and print the custom text insert cards for the LEDs.

2.15.9 BATTERY CHARGERS

Select the DSENet ID of the battery charger to be configured. The ID of the expansion module is set by configuration of the device.



The following options are then shown:

DSENet ID

DSENet ID 0

Enable

Link Lost Alarm Action Shutdown

Modbus Server ID 11

Display Instrumentation

Charger Name Charger ID0

Parameter	Description
Enable	<input type="checkbox"/> = The battery charger with the selected ID is not enabled. <input checked="" type="checkbox"/> = The battery charger with the selected ID is enabled. If the expansion module is not connected / detected by the module, the module generates an <i>Exp. Unit Failure</i> alarm with the configured <i>Link Lost Alarm Action</i> severity.
Modbus server ID	The <i>server ID</i> used to address the battery charger via the host module's RS485 when using the host module as a MODBUS RTU pass through.
Display Instrumentation	<input type="checkbox"/> = The battery chargers' information is not shown on the host module's display. <input checked="" type="checkbox"/> = The battery charger information is shown on the host module's display.
Charger Name	Enter the <i>Charger Name</i> , this text is shown on the module display when viewing the battery charger instrumentation.

2.16 ADVANCED

The *Advanced* page is subdivided into smaller sections. Select the required section with the mouse.

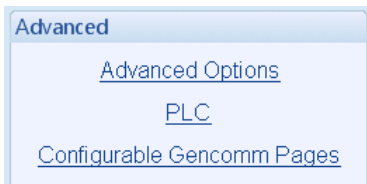

2.16.1 ADVANCED OPTIONS

2.16.1.1 PROTECTIONS

WARNING! - Enabling this feature prevents the set being stopped upon critical alarm conditions. All shutdown alarms are disabled with the exception of EMERGENCY STOP which continues to operate.

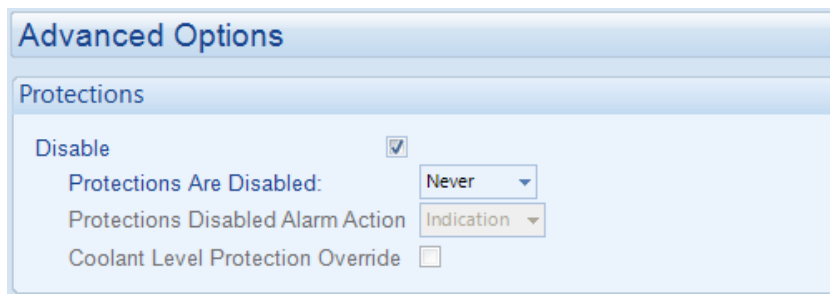

This feature is provided to assist the system designer in meeting specifications for “Warning only”, “Protections Disabled”, “Run to Destruction”, “Battleshort Mode” or other similar wording.

Parameter	Description
Disable	 NOTE: Writing a configuration to the controller that has “Protections Disabled” configured, results in a warning message appearing on the PC screen for the user to acknowledge before the controller’s configuration is changed. This prevents inadvertent activation of the feature.
	<input type="checkbox"/> = The module operates as normal and provide engine shutdown if required. <input checked="" type="checkbox"/> = <i>Protections disabled</i> function is activated. Operation depends upon the following configuration.
Protections are disabled	Never : The protections are not disabled Always : Protections are always overridden by the DSE controller. On Input : Protections are disabled whenever a configurable input set to <i>Protections Disabled</i> is activated
Protections Disabled Alarm Action	If <i>Disable All Protections</i> is set to <i>On Input</i> , this selection allows configuration of an alarm to highlight that the protections have been disabled on the engine. Indication : Any output or LCD display indicator configured to <i>Protections Disabled</i> is made active; however the internal alarm sound does not operate. Warning : Any output or LCD display indicator configured to <i>Protections Disabled</i> is made active, and the internal alarm sound operates. When protections are disabled, <i>Protections Disabled</i> appears on the module display to inform the operator of this status.
Coolant Level Protection Override	<input type="checkbox"/> = When a CANbus engine is selected, the <i>Coolant Level Protection</i> is provided when supported by the ECU (ECM). <input checked="" type="checkbox"/> = The <i>Coolant Level Protection</i> is overridden and does not activate an alarm on the module

2.16.1.2 ESCAPE MODE

The *Escape Mode* is used to instruct the CAN Engine to disable some of its specific ECU alarms to perform a special Maintenance / Regeneration operation while running off-load. The *Escape Mode* is activated through a Digital Input or through the control module's *Running Editor*. This feature is only supported on some electronic CAN engines.

NOTE: Activating *Escape Mode* does not disable the protections by the module.

NOTE: Refer to DSE Publication: *057-253 DSE7310 MKII & DSE7320 MKII Operator Manual* for details on how to activate the *Escape Mode* through the control module's *Running Editor*, available on our website: www.deepseaelectronics.com

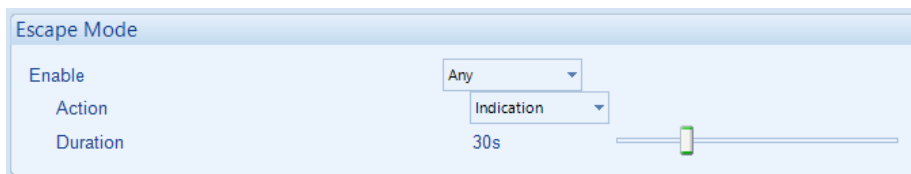

Parameter	Description
Enable	Select to required method to activate <i>Escape Mode</i> . Options are as follows: Any: The <i>Escape Mode</i> is activated when the <i>Escape Mode</i> input function is active or <i>Escape Mode</i> option on the module <i>Running Editor</i> is activated. Disabled: The <i>Escape Mode</i> is disabled, activating the <i>Escape Mode</i> input doesn't activate <i>Escape Mode</i> , and the <i>Escape Mode</i> parameter is hidden on the module's <i>Running Editor</i> On Input: The <i>Escape Mode</i> is activated when the <i>Escape Mode</i> input function is active. With this option <i>Escape Mode</i> parameter is hidden on the module's <i>Running Editor</i> Running Editor: The <i>Escape Mode</i> is activated when the <i>Escape Mode</i> option on the module <i>Running Editor</i> is activated. The module does not respond to the <i>Escape Mode</i> input when active.
Action	Select the action when the <i>Escape Mode</i> is activated through a digital input or from the module's <i>Running Editor</i> . Options are: Indication Warning
Duration	The time duration for the <i>Escape Mode</i> remains active when activated from the module's <i>Running Editor</i> or from the input. Upon termination of this timer the <i>Escape Mode</i> deactivates.

2.16.1.3 SYNCHRONISING TIMERS

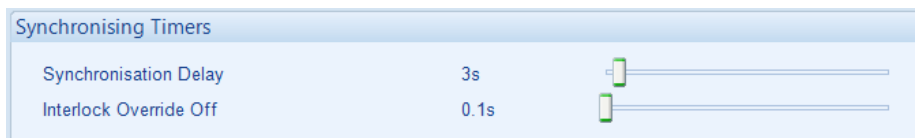

Parameter	Description
Synchronising Delay	This timer starts when a breaker closure is requested in manual mode, either by pressing the <i>Generator Close Button</i> or the <i>Mains Close Button</i> , or upon a Mains Return, it waits for the configured time before it starts the <i>Check Sync</i> process.
Interlock Override Off	This timer activates when the <i>Generator Closed Auxiliary</i> becomes inactive after the <i>Closed Transition</i> , it is used to keep the <i>Interlock Override</i> output active after that the generator breaker has opened to make sure that the breaker has responded correctly.

2.16.1.4 AVR OPTIONS

This feature allows the module to communicate with a supported CAN AVR through its ECU port.

NOTE: At the time of writing, only the DSEA108 and DSEA109 AVRs are supported. For further details, refer to DSE Publication: *057-281 DSEA108 Operator Manual* or *057-295 DSEA109 Operator Manual* available on our website: www.deepseaelectronics.com

NOTE: The module's ECU port's baud rate is defined by the engine file selected in the *Application* section. Most engines' ECU baud rates are set to be 250 kb/s, ensure the baud rate of the AVR matches the engine ECU's baud rate.

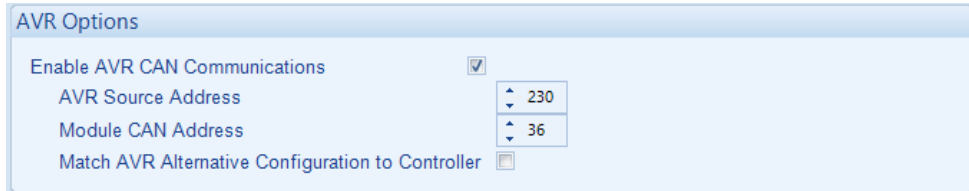

Parameter	Description
Enable AVR CAN Communications	<input type="checkbox"/> = Communications with the CAN AVR is disabled <input checked="" type="checkbox"/> = Enables communication with the CAN AVR through the ECU port.
AVR Source Address	<p>NOTE: For a full list of the AVR CAN message and instrumentation, refer to DSE Publication: <i>057-281 DSEA108 Operator Manual</i> or <i>057-295 DSEA109 Operator Manual</i> which is found on our website: www.deepseaelectronics.com</p> <p>NOTE: For further details on how to configure the DSEA108 CAN Source address, refer to DSE Publication: <i>057-283 DSEA108 Software Manual</i> or <i>057-294 DSEA109 Software Manual</i> which is found on our website: www.deepseaelectronics.com</p> <p>Set the AVR's <i>CAN Source Address</i> to communicate through.</p>
Module CAN Address	The CAN Source address used by the module when sending CAN messages to the AVR.
Match AVR Alternative Configuration to Controller	<p>NOTE: For further details on how to configure the DSEA108 or DSEA109 alternative configurations, refer to DSE Publication: <i>057-283 DSEA108 Software Manual</i> or <i>057-294 DSEA109 Software Manual</i> which is found on our website: www.deepseaelectronics.com</p> <p>This feature is used to send the module's Alternative Configurations Nominal Voltage and Nominal Frequency levels to the CAN AVR, to match the CAN AVR's Alternative Configurations with the module's Alternative Configurations.</p> <p><input type="checkbox"/> = The module does not send its Alternative Configurations settings to the CAN AVR. <input checked="" type="checkbox"/> = The sends its <i>Alternative Configurations' Nominal Voltage</i> and <i>Nominal Frequency</i> levels to the CAN AVR's to match its Alternative Configurations' Voltage Set Point and Frequency select.</p>

2.16.1.5 AVR DATA FAIL

Indicates CAN communication failure between the module and the CAN AVR.

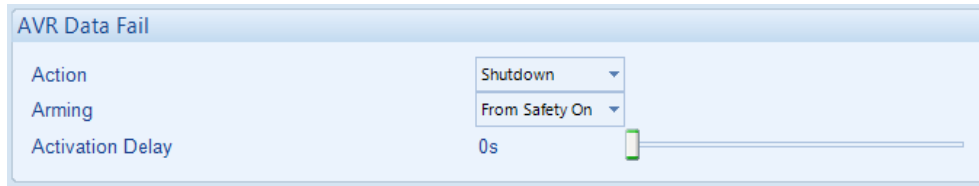

Parameter	Description
Action	Select the action to take when the module detects a communication failure with the CAN AVR. The options are: Electrical Trip Indication Shutdown Warning
Arming	Select when the <i>AVR Data Fail</i> is monitored. Options are as follows: Always: The alarm is active at any time the CAN Link is lost From Safety On: Active only after the <i>Safety On</i> delay timer From Starting: Active only after the <i>Crank Relay</i> is energised Never: Alarm is disabled Loading Alarms Activation: The alarm is monitored after the generator is running, and the voltage and frequency are above their <i>Loading</i> levels, until the generator stops.
Activation Delay	The time delay for the module to wait before activating <i>AVR Data Fail</i> alarm when detected.

2.16.1.6 AVR FAULT

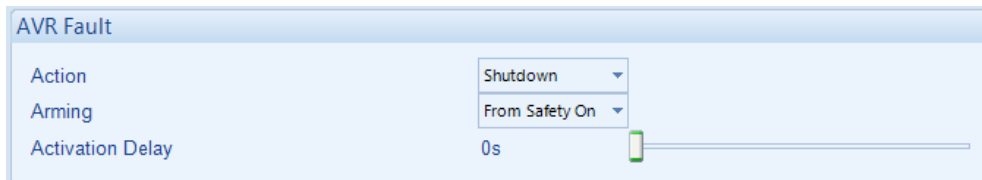

Parameter	Description
Action	Select the action to take after the <i>Activation Delay</i> timer, when the CAN AVR activates an alarm. The options are: Electrical Trip Indication Shutdown Warning
Arming	Select when the <i>AVR Fault</i> is monitored. Options are as follows: Always: The alarm is active at any time the CAN Link is lost From Safety On: Active only after the <i>Safety On</i> delay timer From Starting: Active only after the <i>Crank Relay</i> is energised
Activation Delay	The time delay for the module to wait before activating <i>AVR Fault</i> alarm when detected.

2.16.2 PLC

The *PLC* section is subdivided into smaller sub-sections.

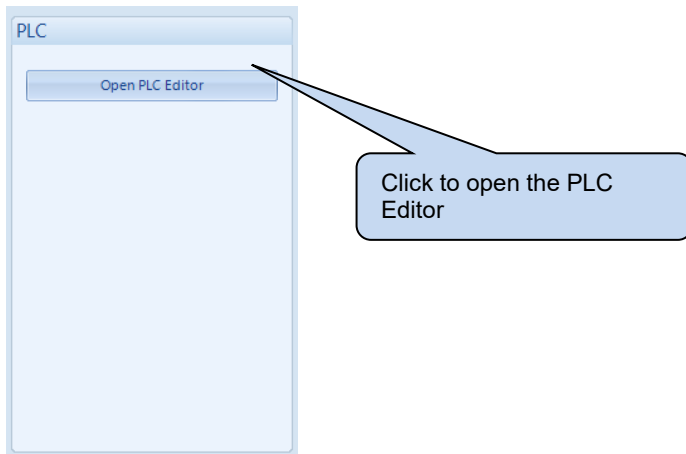

2.16.2.1 PLC LOGIC

NOTE: For further details and instructions on PLC Logic and PLC Functions, refer to DSE Publication: 057-314 Advanced PLC Programming Guide for DSE Modules which is found on our website: www.deepseaelectronics.com

This section displays the real-time status of the *PLC Logic* configured within the module. *This section is useful for assisting with fault finding issues relating to or caused by the PLC Logic.*

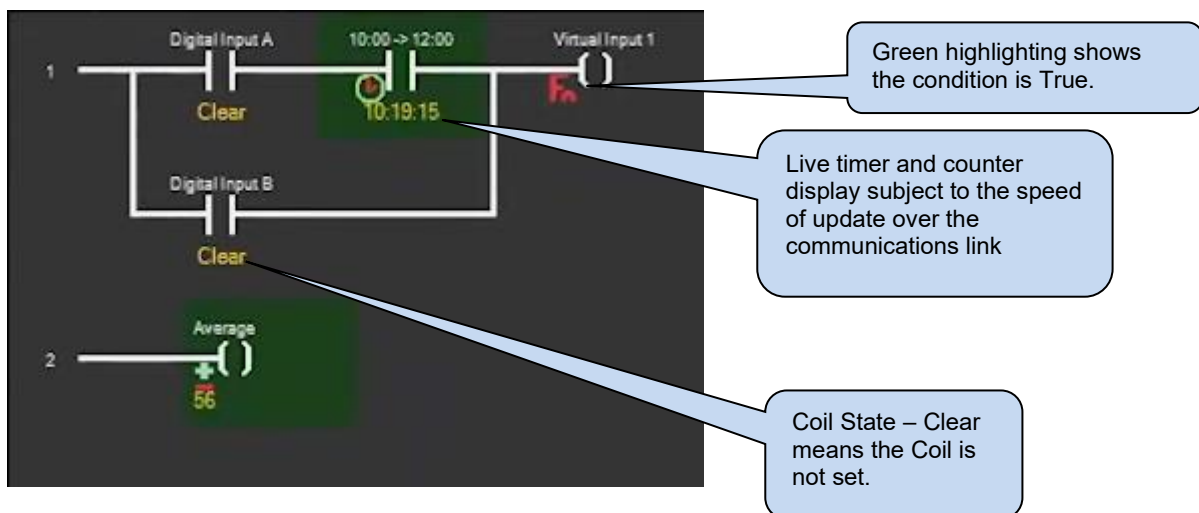

2.16.2.2 PLC FUNCTIONS

NOTE: For further details and instructions on PLC Logic and PLC Functions, refer to DSE Publication: *057-314 PLC Programming Guide* which is found on our website: www.deepseaelectronics.com

PLC Functions allow the PLC logic to create alarm conditions or drive 'virtual inputs' on the controller. A PLC function is configured in the same way as a module digital input.

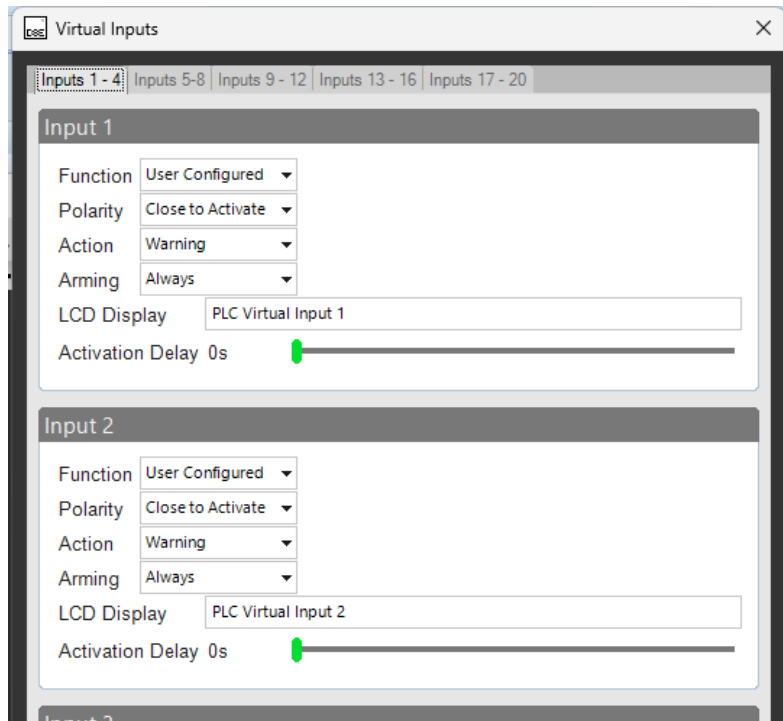

2.16.3 CONFIGURABLE GENCOMM PAGES

Select the required section with the mouse.

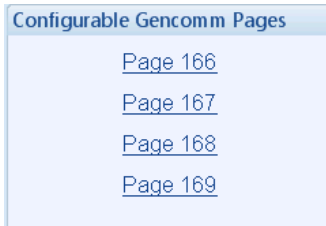

For advanced MODBUS users of the controller, configurable Gencomm pages are available. The intention is to allow the user to create personal collections of data in subsequent registers to minimise the number of MODBUS reads required by the client and hence speed up data collection.

All configurable Gencomm registers are 32-bit unsigned format.

Gencomm Page 166							
Register	Value	Register	Value	Register	Value	Register	Value
0-1	<Not Used>	64-65	<Not Used>	128-129	<Not Used>	192-193	<Not Used>
2-3	<Not Used>	66-67	<Not Used>	130-131	<Not Used>	194-195	<Not Used>
4-5	<Not Used>	68-69	<Not Used>	132-133	<Not Used>	196-197	<Not Used>
6-7	<Not Used>	70-71	<Not Used>	134-135	<Not Used>	198-199	<Not Used>
8-9	<Not Used>	72-73	<Not Used>	136-137	<Not Used>	200-201	<Not Used>
10-11	<Not Used>	74-75	<Not Used>	138-139	<Not Used>	202-203	<Not Used>
12-13	<Not Used>	76-77	<Not Used>	140-141	<Not Used>	204-205	<Not Used>
14-15	<Not Used>	78-79	<Not Used>	142-143	<Not Used>	206-207	<Not Used>
16-17	<Not Used>	80-81	<Not Used>	144-145	<Not Used>	208-209	<Not Used>
18-19	<Not Used>	82-83	<Not Used>	146-147	<Not Used>	210-211	<Not Used>
20-21	<Not Used>	84-85	<Not Used>	148-149	<Not Used>	212-213	<Not Used>
22-23	<Not Used>	86-87	<Not Used>	150-151	<Not Used>	214-215	<Not Used>
24-25	<Not Used>	88-89	<Not Used>	152-153	<Not Used>	216-217	<Not Used>
26-27	<Not Used>	90-91	<Not Used>	154-155	<Not Used>	218-219	<Not Used>
28-29	<Not Used>	92-93	<Not Used>	156-157	<Not Used>	220-221	<Not Used>
30-31	<Not Used>	94-95	<Not Used>	158-159	<Not Used>	222-223	<Not Used>
32-33	<Not Used>	96-97	<Not Used>	160-161	<Not Used>	224-225	<Not Used>
34-35	<Not Used>	98-99	<Not Used>	162-163	<Not Used>	226-227	<Not Used>
36-37	<Not Used>	100-101	<Not Used>	164-165	<Not Used>	228-229	<Not Used>
38-39	<Not Used>	102-103	<Not Used>	166-167	<Not Used>	230-231	<Not Used>
40-41	<Not Used>	104-105	<Not Used>	168-169	<Not Used>	232-233	<Not Used>
42-43	<Not Used>	106-107	<Not Used>	170-171	<Not Used>	234-235	<Not Used>
44-45	<Not Used>	108-109	<Not Used>	172-173	<Not Used>	236-237	<Not Used>
46-47	<Not Used>	110-111	<Not Used>	174-175	<Not Used>	238-239	<Not Used>

The configurable MODBUS pages are:

Page	Hex address	Decimal address
166	A600	42496
167	A700	42752
168	A800	43008
169	A900	43264

Example of Gencomm page configuration:

Page 166	
Register	Value
0-1	Engine At Rest
2-3	Engine Speed
4-5	Fuel Temperature
6-7	Oil Pressure

The register address is obtained from the formula: $\text{register_address} = \text{page_number} * 256 + \text{register_offset}$.
To read the *Engine Speed* from the above register, the MODBUS client device needs to read the data in two registers and then combine the data from the Most Significant Bit and the Least Significant Bit.
MSB address in Decimal = $(166 * 256) + 2 = 42498$
LSB address in Decimal = $(166 * 256) + 3 = 42499$

3 SCADA

SCADA stands for **S**upervisory **C**ontrol **A**nd **D**ata **A**cquisition and is provided both as a service tool and also as a means of monitoring / controlling the generator set.

As a service tool, the SCADA pages are to check the operation of the controller's inputs and outputs as well as checking the generators operating parameters.

The diagram shows a 'Scada' button with a '+' icon and a '7320 (RTH) MKII Scada v1.1' button with a '-' icon. Callouts explain the functions of these buttons.

- Click to open the connection to the module. If no module is connected, the SCADA opens to show the screens for the type of module currently open in the configuration.
- When connection is made...
- Click to close the connection to the module.
- The Module's firmware revision number.

The SCADA page is subdivided into smaller sections. Select the required section with the mouse.

The screenshot shows the '7320 SCADA' page with the following sections listed:

- [Generator Identity](#)
- [Mimic](#)
- [Digital Inputs](#)
- [Digital Outputs](#)
- [Virtual LEDs](#)
- [Mains](#)
- [Generator](#)
- [Engine](#)
- [Fuel Use and Efficiency](#)
- [Flexible Sensors](#)
- [Configurable CAN Instrumentation](#)
- [Alarms](#)
- [Engine Alarms](#)
- [Status](#)
- [Event Log](#)
- [Enhanced CANbus](#)
- [Remote Control](#)
- [Maintenance](#)
- [Data Log](#)
- [PLC](#)
- [AVR](#)
- [Expansion](#)

3.1 GENERATOR IDENTITY

Shows the module's current settings for *Site ID* and *Genset ID*



3.2 MIMIC

This screen provides a mimic of the control module and allows the operator to change the control mode of the module.



Hint : Buttons may not operate if this has been locked out by the *Access Permissions* security feature of the Configuration Suite software. Refer to the system supplier for details.

Click the *mimic* buttons to control the module remotely

3.3 LANGUAGES

Languages

Current language in the module.

Current Module Language
English

To upload <No suitable language files>

Select new language

Click to send the new language to the module

Upload Now

3.4 DIGITAL INPUTS

Digital Inputs

	Active	Open / Closed
A Simulate Auto Button	●	⏏
B Remote Start on Load	●	⏏
C Lamp Test	●	⏏
D External Panel Lock	●	⏏
E Remote Start off Load	●	⏏
F Transfer to Generator / Open Mains	●	⏏
G Digital input G	●	⏏
H Alarm Reset	●	⏏
Emergency Stop	●	⏏

Shows if the input channel is active or not. This input is *closed* and is active. The input is configured to be *close to activate*

State of the input (open or closed to battery negative)

Shows if the input channel is active or not. This input is *open* but is active. The input is configured to be *open to activate*

State of the Emergency stop input (open or closed to battery positive). This input **MUST** be closed to battery positive for *normal* operation. If the input is open, the set is stopped if it's already running and not allowed to start.

3.5 DIGITAL OUTPUTS

Digital Outputs			
Digital Outputs (Supplied From Emergency Stop Input)			
		Active	Open / Closed
A	Fuel Relay		
B	Start Relay		
Digital Outputs (Volts Free)			
		Active	Open / Closed
C	Not Used		
D	Inhibit Scheduled Run		
Digital Outputs (DC Supply Out)			
		Active	Open / Closed
E	Preheat During Preheat Timer		
F	Combined Remote Start Output		
G	Lamp Test		
H	System In Manual Mode		
I	Not Used		
J	Not Used		

State of the output (open or closed)

Shows if the output channel is active or not. This output is *closed* and is active. The output is configured to be *System in Manual Mode Energise*. As the module is in Manual mode, the output is *energised*.

3.6 VIRTUAL LEDS

Shows the state of the *Virtual LEDs*. These LEDs are not fitted to the module or expansion modules, they are not physical LEDs. They are provided to show status and appear only in the SCADA section of the configuration suite or read by third party PLC or Building Management Systems (for example) using the MODBUS RTU protocol.

The screenshot shows a window titled "Virtual LEDs" with a sub-section "LED Status". It contains a table with 20 rows, each representing an LED. The first column is the LED number (LED 1 to LED 20), and the second column is the LED name. To the right of the names is a vertical column of green circles, each representing the active status of the corresponding LED. The word "Active" is positioned above this column. Two callout boxes provide additional information: one points to the green circles, stating "Shows if the Virtual LED is active or not.", and another points to the LED names, stating "Shows what the Virtual LED is configured for (shows the LED number if not configured)."

LED Number	LED Name	Active Status
LED 1	Combined Remote Start Output	Active
LED 2	Fuel Relay	Active
LED 3	Start Relay	Active
LED 4	Common Alarm	Active
LED 5	Not Used	Not Active
LED 6	Common Warning	Active
LED 7	Common Shutdown	Active
LED 8	Not Used	Not Active
LED 9	Not Used	Not Active
LED 10	Not Used	Not Active
LED 11	Not Used	Not Active
LED 12	Not Used	Not Active
LED 13	Not Used	Not Active
LED 14	Not Used	Not Active
LED 15	Not Used	Not Active
LED 16	Not Used	Not Active
LED 17	Not Used	Not Active
LED 18	Not Used	Not Active
LED 19	Not Used	Not Active
LED 20	Not Used	Not Active

3.7 MAINS



= Only available on DSE7320 MKII AMF Modules

The *Mains* section is subdivided into smaller sections.
Select the required section with the mouse.

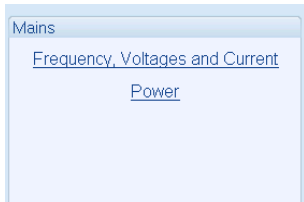

3.7.1 FREQUENCY, VOLTAGES AND CURRENT

Shows the module's measurements of the mains supply (DSE7320 MKII only).

Mains		
Frequency		
49.9 Hz		
Phase Rotation		
L1-L2-L3		
Phase To Neutral Voltages		
L1 - N 230.2 V	L2 - N 226.9 V	L3 - N 231.6 V
Phase To Phase Voltages		
L1 - L2 395.1 V	L2 - L3 397.2 V	L3 - L1 401.0 V
Mains Current		
L1 85.0 A	L2 86.0 A	L3 86.0 A
Earth Current		
27.0 A		

Mains current is displayed when the CTs are placed in the *load* and the mains is on load.

3.7.2 POWER

Shows the modules measurements of the mains supply power (DSE7320 MKII only).

Power				
Watts				
	L1	L2	L3	Total
	3.0 kW	3.0 kW	3.0 kW	9.0 kW
VA				
	L1	L2	L3	Total
	10.0 kVA	10.0 kVA	10.0 kVA	30.0 kVA
VAr				
	L1	L2	L3	Total
	8.0 kVAr	8.0 kVAr	8.0 kVAr	24.0 kVAr
Power factor				
	L1	L2	L3	Average
Lag	0.32	Lag 0.32	Lag 0.31	Lag 0.30
Accumulated Power				
	kWh	kVAh	kVArh	
	107.7 kWh	174.2 kVAh	75.0 kVArh	

3.8 GENERATOR

The *Generator* section is subdivided into smaller sections. Select the required section with the mouse.

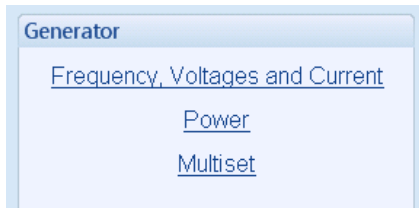

3.8.1 FREQUENCY, VOLTAGES AND CURRENT

Shows the modules measurements of the generator supply.

A screenshot of a monitoring panel titled "Frequency, Voltages and Current". The panel is divided into several sections, each with a header and a data display area:

- Frequency:** Displays "0.0 Hz".
- Phase to Neutral Voltages:** Displays three values: "L1 - N" (0.0 v), "L2 - N" (0.0 v), and "L3 - N" (0.0 v).
- Phase to Phase Voltages:** Displays three values: "L1 - L2" (0.0 v), "L2 - L3" (0.0 v), and "L3 - L1" (0.0 v).
- Current:** Displays three values: "L1" (0.0 A), "L2" (0.0 A), and "L3" (0.0 A).
- Earth Current:** Displays "0.0 A".

3.8.2 POWER

Shows the module's measurements of the generator supply power.

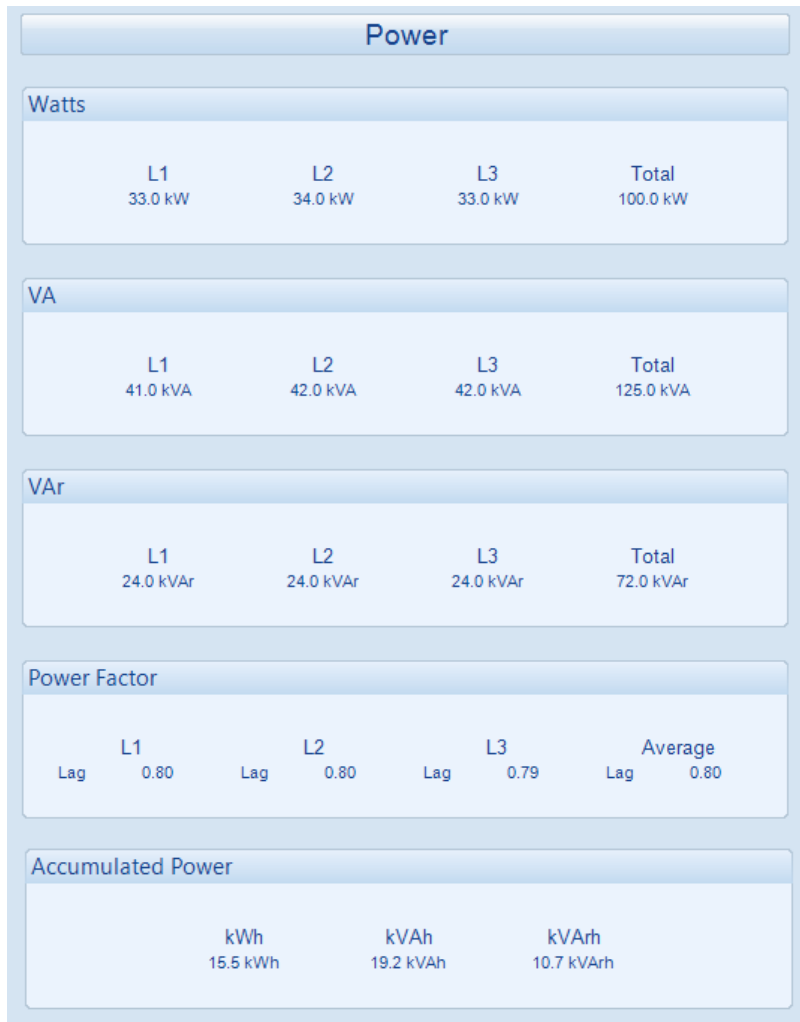

3.8.3 MULTISET

Allows setting the module's MSC link parameters.

Parameter	Description
Sets On The Bus	Shows the number of modules currently connected to the MSC link.
MSC ID	Each controller connected to the MSC link must have a unique ID. When all the controllers are powered up "one at a time", this is automatically set. If powering all modules up at the same time results in "MSC ID alarm", manually setting the <i>MSC ID</i> here prevents this.
Priority	Used when the <i>Dual Mutual Standby</i> is in operation and the <i>Balancing Mode</i> is configured to <i>Set Priority</i> .
Dual Mutual Time	This is an incremental internal hours counter used only for the <i>Dual Mutual Standby</i> when the <i>Balancing Mode</i> is set to <i>Dual Mutual Time</i> . It holds the accumulated hours counter for the <i>Duty Time</i> of operation.

3.9 ENGINE

Shows the modules measurements of the engine parameters.

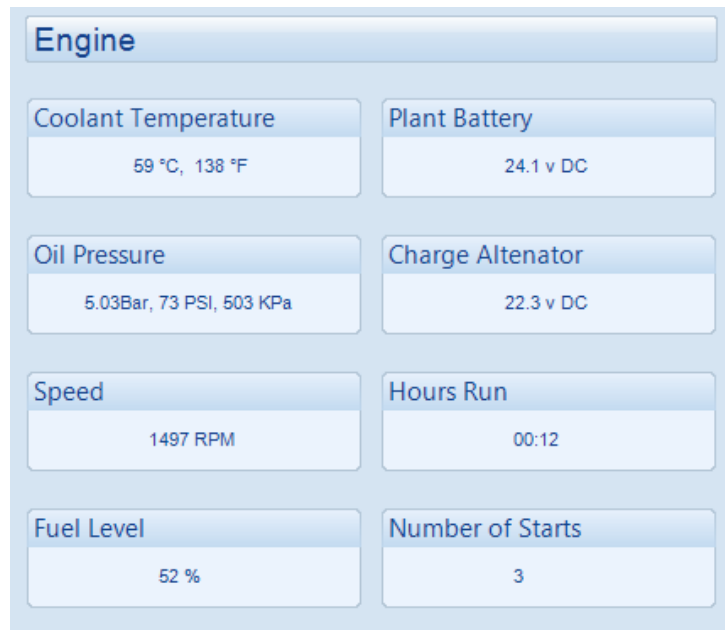

3.10 FUEL USE AND EFFICIENCY

Shows the measurement of the fuel use and efficiency (If configured)

Fuel Use and Efficiency		
Fuel Consumption		
Instantaneous 100.77 l/hr	Trip 142.38 l/hr	
Fuel Use		
Trip ---		Accumulated 2049 litres
Fuel Efficiency		
Instantaneous 315.65 kWh/l	Trip 0.00 kWh/l	Accumulated 3.40 kWh/l
Run Time Until Empty		
17:46		

3.11 FLEXIBLE SENSORS

The *Flexible Sensors* section is subdivided into smaller sections. Select the required section with the mouse.



Shows the modules measurements of the flexible sensors parameters.

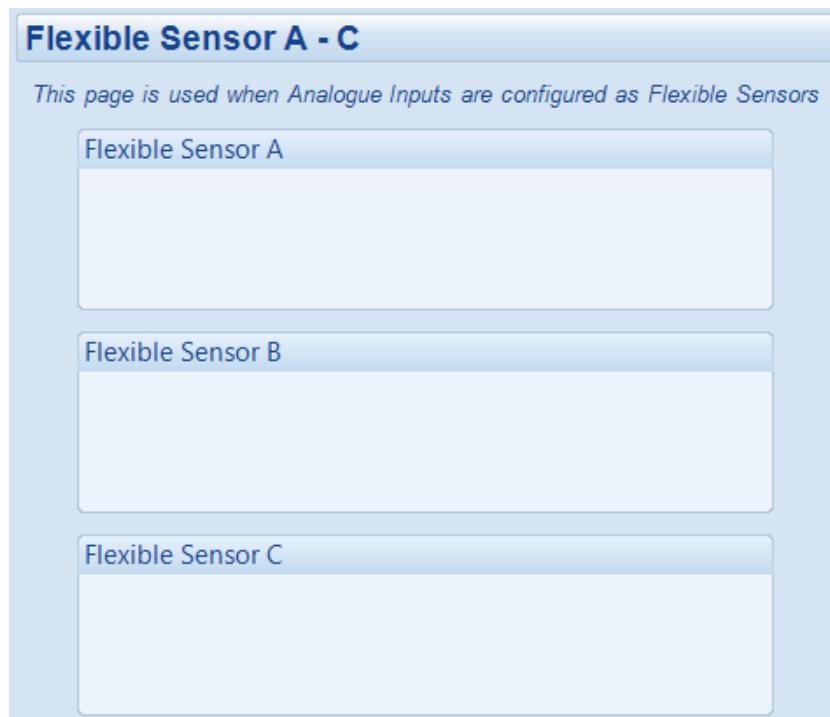

3.12 CONFIGURABLE CAN INSTRUMENTATION

Shows the module's readings of the configured *CAN Instrumentation*. This is only available if the module is configured for *Configurable CAN Instrumentation*, the *Enhanced Canbus* option is enabled, and the message is available over the relevant configured CAN bus.

Configurable CAN Instrumentation		
Configurable CAN Instrumentation		
1	Longitude - VP	210.0072902
2	Engine Oil Pressure - EFL_P1	124 kPa
3	Latitude - VP	1.0036625
4	Engine Coolant Pressure - EFL_P1	234 kPa
5	Engine Fuel Pressure - EFL_P1	0 kPa
6	Engine Hours - HOURS	1000.0 hr
7	Engine Oil Temperature 1 - ET1	84.37042 deg C
8	Engine Coolant Temperature - ET1	55 deg C
9	Engine Fuel Rate - LFE	10.00 L/h
10	Electrical Potencial Plnp - VEP1	0.00 V

3.13 ALARMS

Shows any present alarm conditions.

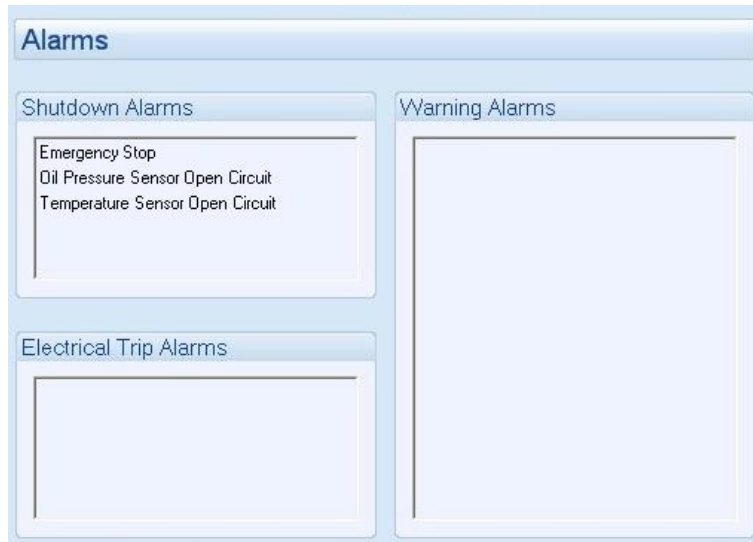

3.14 ENGINE ALARMS

The *Engine Alarms* page is subdivided into smaller sections. Select the required section with the mouse.

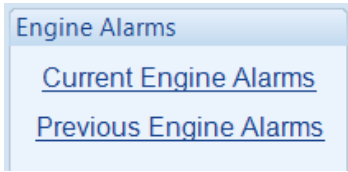

3.14.1 CURRENT ENGINE ALARMS

This section displays the list of active *ECU Current DTCs* (Diagnostic Trouble Codes) which are being read from the engine's ECU. *ECU Current DTCs* are DM1 messages and are only read when the engine's ECU is awake (powered up). For information, refer to DSE publication: **057-004 Electronic Engines And DSE Wiring** which is found on the DSE website: www.deepseaelectronics.com.

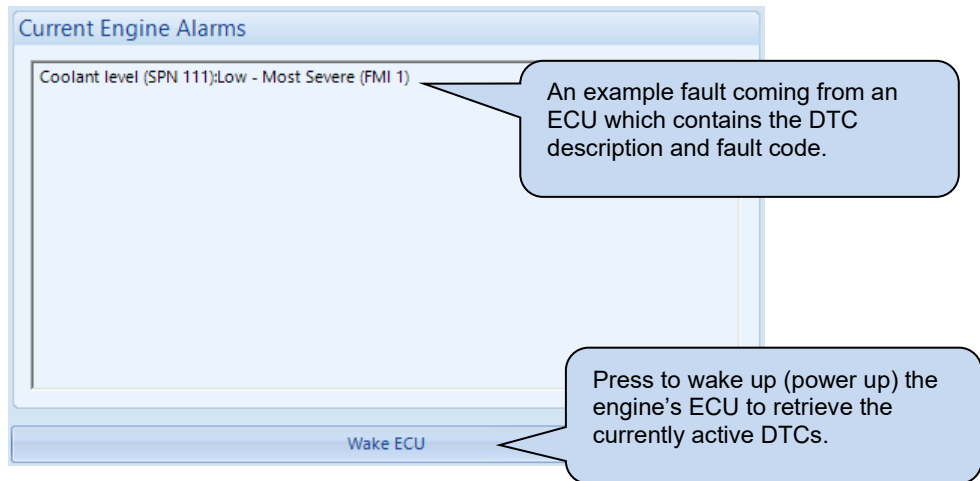

3.14.2 PREVIOUS ENGINE ALARMS

Shows the previous engine alarms.

This section displays the list of active *ECU Previous DTCs* (Diagnostic Trouble Codes) which are being read from the engine's ECU. *ECU Previous DTCs* are DM2 messages and are only read when the engine's ECU is awake (powered up). For information, refer to DSE publication: **057-004 Electronic Engines And DSE Wiring** which is found on the DSE website: www.deepseaelectronics.com.

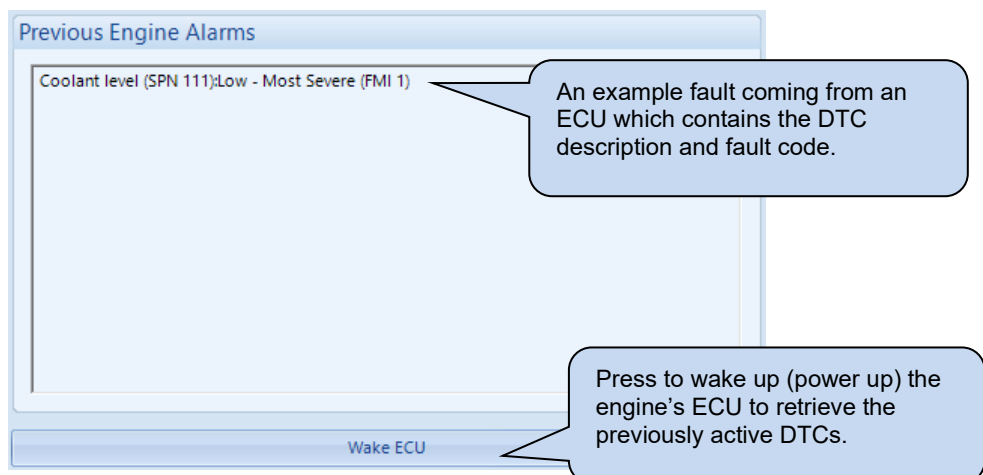

STATUS

Shows the module's current status.

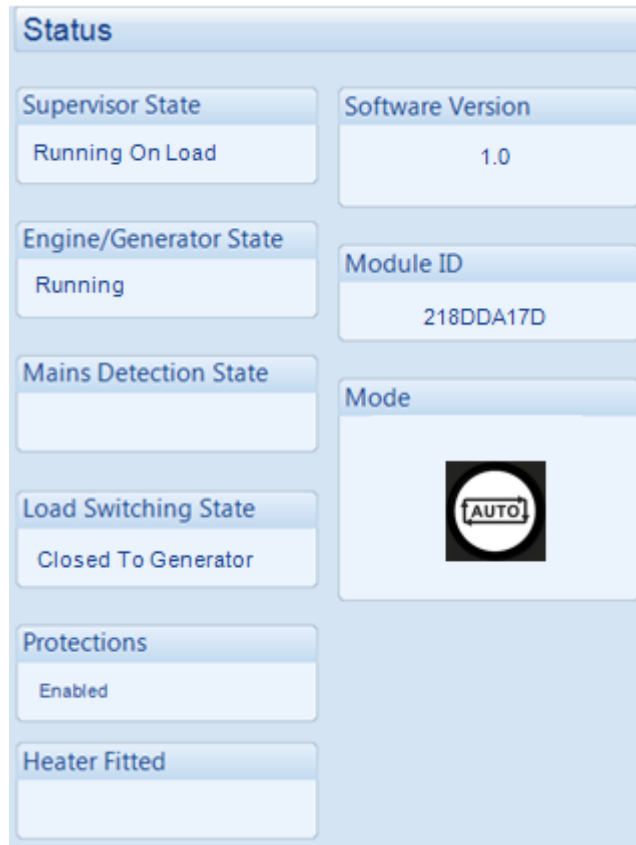

The image shows a SCADA status panel with a light blue background and a title bar labeled "Status". The panel is organized into two columns of information boxes. The left column contains: "Supervisor State" (Running On Load), "Engine/Generator State" (Running), "Mains Detection State" (empty), "Load Switching State" (Closed To Generator), "Protections" (Enabled), and "Heater Fitted" (empty). The right column contains: "Software Version" (1.0), "Module ID" (218DDA17D), and "Mode" (represented by a black square icon with a white circle and the word "AUTO" inside).

Status	
Supervisor State	Software Version
Running On Load	1.0
Engine/Generator State	Module ID
Running	218DDA17D
Mains Detection State	Mode
	
Load Switching State	
Closed To Generator	
Protections	
Enabled	
Heater Fitted	

3.15 EVENT LOG

Shows the contents of the module's event log.

#	Date	Time	Hours Run	Event	Details
1	02/10/2008	11:41:20	0:12	Shutdown	Oil Pressure Sensor Open Circuit
2	02/10/2008	11:41:19	0:12	Mains	Mains fail
3	02/10/2008	11:41:18	0:12	Restart	Power Up
4	28/09/2008	08:24:43	0:12	Shutdown	Oil Pressure Sensor Open Circuit
5	28/09/2008	08:24:42	0:12	Mains	Mains fail
6	28/09/2008	08:24:40	0:12	Restart	Power Up
7	27/09/2008	07:48:17	0:12	Shutdown	Oil Pressure Sensor Open Circuit
8	27/09/2008	07:48:16	0:12	Mains	Mains fail
9	27/09/2008	07:48:14	0:12	Restart	Power Up
10	27/09/2008	07:31:00	0:12	Shutdown	Oil Pressure Sensor Open Circuit
11	27/09/2008	07:30:59	0:12	Mains	Mains fail
12	27/09/2008	07:30:57	0:12	Restart	Power Up
13	26/09/2008	07:48:19	0:12	Shutdown	Oil Pressure Sensor Open Circuit
14	26/09/2008	07:48:18	0:12	Mains	Mains fail
15	26/09/2008	07:48:17	0:12	Restart	Power Up
16	26/09/2008	07:45:58	0:12	Restart	Power Up
17	26/09/2008	06:54:11	0:12	Shutdown	Oil Pressure Sensor Open Circuit
18	26/09/2008	06:54:10	0:12	Mains	Mains fail
19	26/09/2008	06:54:09	0:12	Restart	Power Up
20	25/09/2008	08:56:38	0:12	Shutdown	Oil Pressure Sensor Open Circuit
21	25/09/2008	08:56:37	0:12	Mains	Mains fail
22	25/09/2008	08:56:35	0:12	Restart	Power Up
23	25/09/2008	08:52:50	0:12	Mains	Mains fail
24	25/09/2008	08:52:48	0:12	Restart	Power Up
25	25/09/2008	06:55:04	0:12	Shutdown	Oil Pressure Sensor Open Circuit
26	25/09/2008	06:55:03	0:12	Mains	Mains fail

Export to Excel Export to CSV Export to PDF Print event log

Click to save the log to an Excel file for use in a spreadsheet

Click to save the log to a csv file for use in an external spreadsheet program.

Click to save the log to a pdf (Adobe Acrobat) file.

Click to print the log.

ENHANCED CANBUS



Shows the module's readings of enhanced Canbus parameters. This is only available if the module is configured for CAN communication and the *Enhanced Canbus* option is enabled.

Enhanced CANbus	
Engine Oil Temperature Bad Data	Inlet Manifold Temperature Temp. 1 Temp. 2 Bad Data
Exhaust Temperature Temp. 1 Temp. 2	Coolant Pressure Press. 1 Press. 2
Fuel Pressure Press. 1 Press. 2	Turbo Pressure Press. 1 Press. 2
Total Fuel Used 	Fuel Consumption

3.17 REMOTE CONTROL

The remote control section of the SCADA section is used for monitoring and control of module 'remote control' sources.

Any of the module outputs, expansion outputs, LED indicators, or remote Annunciator LEDs are to be configured to *Remote Control 1-10*. This output source is energised/de-energised by click the respective check box as shown below in the *Activate* column below.

Remote Control		
Remote Control Sources		
Control	Activate	Active
1	<input checked="" type="checkbox"/>	
2	<input type="checkbox"/>	
3	<input type="checkbox"/>	
4	<input checked="" type="checkbox"/>	
5	<input type="checkbox"/>	
6	<input type="checkbox"/>	
7	<input checked="" type="checkbox"/>	
8	<input type="checkbox"/>	
9	<input type="checkbox"/>	
10	<input type="checkbox"/>	

3.18 MAINTENANCE

The *Maintenance* section is subdivided into smaller sections. Select the required section with the mouse.

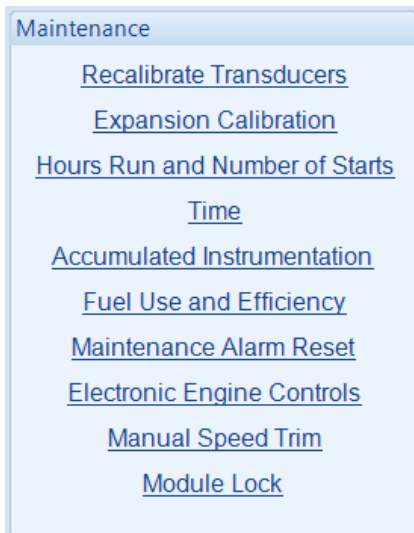

3.18.1 RECALIBRATE TRANSDUCERS

The *Recalibrate Transducers* section is subdivided into smaller sections. Select the required section with the mouse.

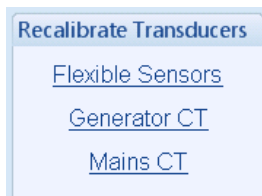

3.18.1.1 FLEXIBLE SENSORS

Allows the recalibration of the flexible sensors (when enabled in the module configuration).

Flexible Sensor A - C

This page is used when Analogue Inputs are configured as Flexible Sensors

Flexible Sensor A

Flexible Sensor A
3 °C

Flexible Sensor B

Flexible Sensor B
105 °C

Flexible Sensor C

Flexible Sensor C
74 % 740 Litres

3.18.1.2 GENERATOR CT

Allows the recalibration of the generator CT readings.

Generator CT

Current L1



Current L2



Current L3



Current Earth/Neutral



Reset

Reset to Default

3.18.1.3 MAINS CT



= Only available on DSE7320 MKII AMF Modules and when the *CT Location* is configured to *Load*.

Mains CT

Current L1



Current L2



Current L3



Current Earth/Neutral



Reset

Reset to Default

3.18.2 EXPANSION CALIBRATION

This section allows the analogue sensor inputs of the DSE2130 and DSE2131 expansion modules to be calibrated to remove inaccuracies caused by the tolerance of the sensor devices. While the engine is running, the instruments are calibrated and reference needs to be made to a third party accurate sensing device to ensure accurate recalibration.

Select the required section with the mouse.



3.18.3 HOURS RUN AND NUMBER OF STARTS

This section allows the *Hours Run* and *Number of Starts* to be customised on the controller. Typically, this is used when fitting a new controller to an older engine so that the controller display matches the amount of work previously done by the system.

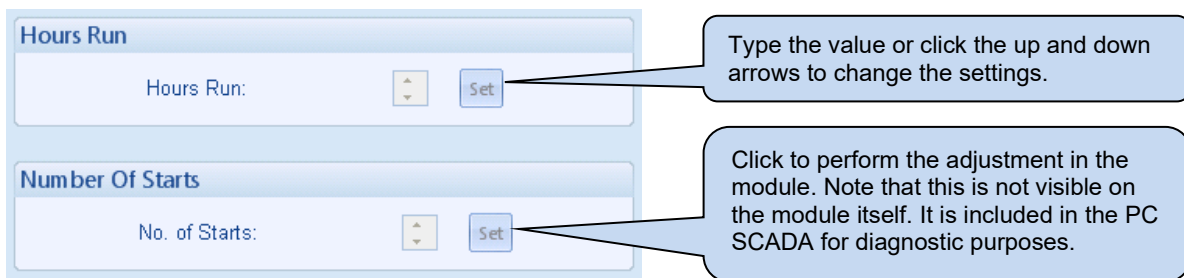

3.18.4 TIME

This section allows the day and time to be set and changed on the controller.

The screenshot displays the 'Date and Time' configuration page, which is organized into several sections:

- Date and Time**: The main title of the configuration area.
- Module Date**: A field showing the current date as 21/01/2014. A callout points to this field with the text: "Display of the module's current date and time."
- Module Time**: A field showing the current time as 09:53:10.
- Set Date And Time**: A section for manual configuration. It includes:
 - A 'Date' field with a dropdown arrow, currently showing 14/02/2000. A callout points to this field with the text: "Type the new date / time or click the up and down arrows to change the settings."
 - A 'Time' field with a dropdown arrow, currently showing 05:29:57.
 - A 'Set' button below the date and time fields. A callout points to this button with the text: "Click Set to adjust the module to the selected date/time."
- Set To PC Time**: A section for synchronizing with the PC. It includes:
 - A 'Date' field showing 21/01/2014.
 - A 'Time' field showing 09:53:11.
 - A 'Set To PC Time' button. A callout points to this button with the text: "Click Set to adjust the module to the date/time that your PC is set to."

3.18.5 ACCUMULATED INSTRUMENTATION

The *Accumulated Instrumentation* section is subdivided into smaller sections. Select the required section with the mouse.

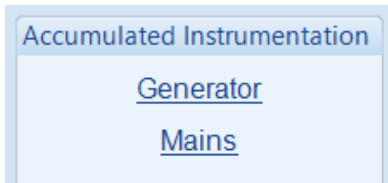

3.18.5.1 GENERATOR

Allows the user to view or change the module's Generators accumulated instrumentation.

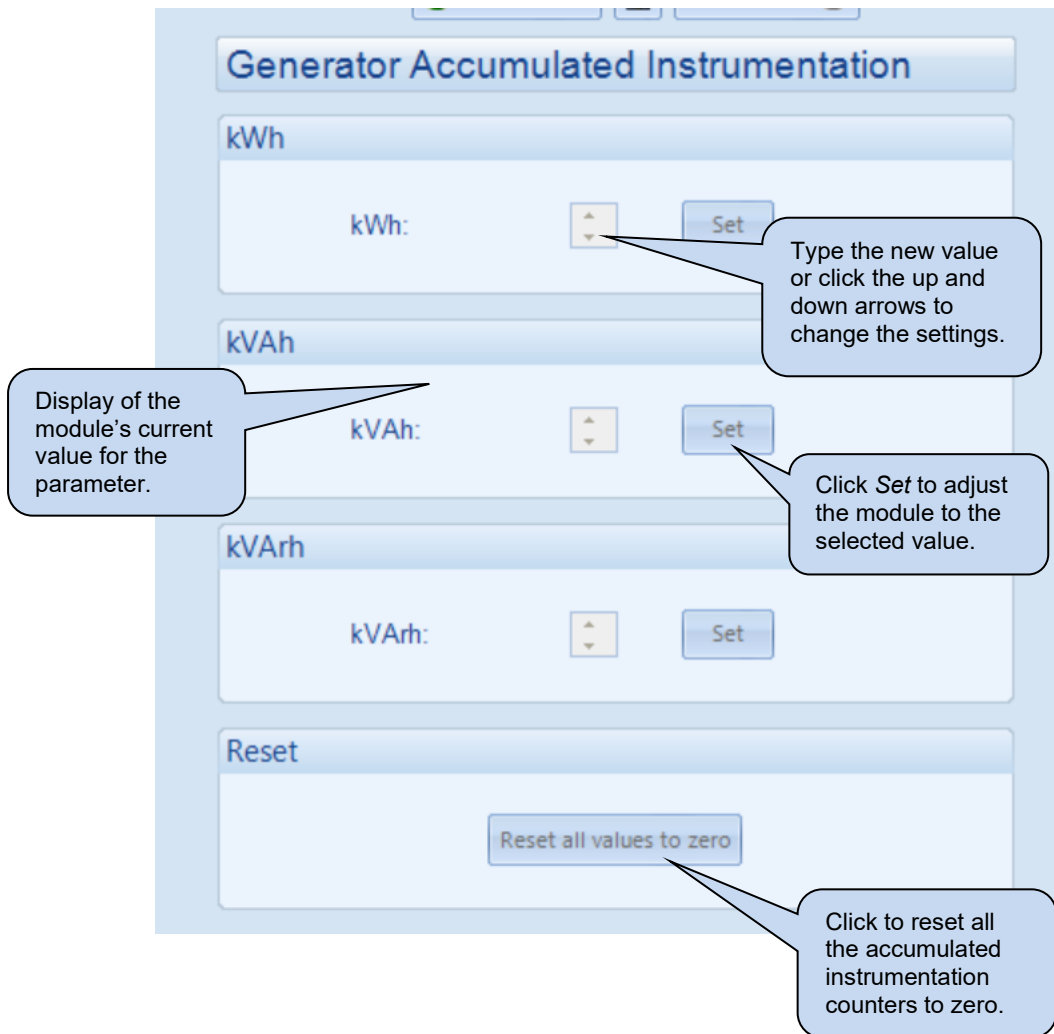

3.18.5.2 MAINS



= Only available on DSE7320 MKII AMF Modules and when the *CT Location* is configured to *Load*.

Allows the user to view or change the module's Mains accumulated instrumentation.

The screenshot shows a user interface for configuring Mains accumulated instrumentation. It consists of four main sections: kWh, kVAh, kVArh, and a Reset section. Each section displays a current value and a control interface for setting a new value. Callouts provide instructions on how to interact with these elements.

Parameter	Current Value	Target Value	Control
kWh	154.0 kWh	154.0	Set
kVAh	100.0 kVAh	100.0	Set
kVArh	85.0 kVArh	85.0	Set

Reset Section: A button labeled "Reset all values to zero" is located at the bottom of the interface.

Callouts:

- Display of the module's current value for the parameter.** (Points to the kWh value)
- Type the new value or click the up and down arrows to change the settings.** (Points to the kWh target value)
- Click Set to adjust the module to the selected value.** (Points to the kWh Set button)
- Click to reset all the accumulated instrumentation counters to zero.** (Points to the Reset button)

3.18.6 FUEL USE AND EFFICIENCY

The screenshot shows a SCADA interface with three main sections: 'Accumulated Fuel Use', 'Fuel Use', and 'Reset'. The 'Accumulated Fuel Use' section is at the top. Below it is the 'Fuel Use' section, which displays 'Fuel Use: 135 litres' and a numeric input field containing '135' with up and down arrows. To the right of the input field is a 'Set' button. The 'Reset' section is at the bottom and contains a button labeled 'Reset all values to zero'. Three callout boxes provide instructions: one pointing to the input field, one pointing to the 'Set' button, and one pointing to the 'Reset all values to zero' button.

Accumulated Fuel Use

Fuel Use

Fuel Use: 135 litres

Reset

Type the new value or click the up and down arrows to change the settings.

Click Set to adjust the module to the selected value.

Click to reset all the values to zero.

3.18.7 MAINTENANCE ALARM RESET

Three maintenance alarms active in the control module. Each is reset individually.

The screenshot displays a 'Maintenance Alarm Reset' interface with three distinct alarm panels, each containing the following information:

- Maintenance Alarm 1:** Running Time Until Next Maintenance: 10:00; Date Of Next Maintenance.
- Maintenance Alarm 2:** Running Time Until Next Maintenance: 1000:00; Date Of Next Maintenance.
- Maintenance Alarm 3:** Running Time Until Next Maintenance: 100:00; Date Of Next Maintenance.

Each panel includes a 'Reset' button and a note: 'Press reset to schedule next maintenance, based upon module's maintenance configuration.' A callout box points to the 'Reset' button of Maintenance Alarm 2, containing the text: 'Reset the maintenance alarm based upon the module's configuration.'

3.18.8 ELECTRONIC ENGINE CONTROLS

This section allows settings within the engine's ECU to be altered when supported.

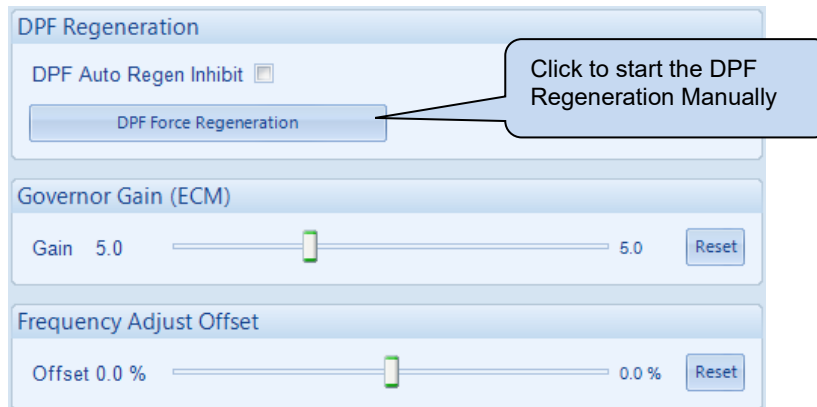

Parameter	Description
DPF Auto Regen Inhibit	<input type="checkbox"/> = The ECU's DPF Auto Regeneration happens automatically. <input checked="" type="checkbox"/> = The ECU's DPF Auto Regeneration is inhibited from activating.
Governor Gain (ECM)	The setting for the <i>Gain (P)</i> of the ECU/ECM's control loop over the engine speed.
Frequency Adjust Offset	A positive/negative offset that is applied to the entire ECU/ECM's droop setting as percentage its configured nominal speed. An <i>Offset</i> of -1% with a nominal speed of 1500 RPM would result in the entire ECU's droop curve being offset by 15 RPM.

3.18.9 MANUAL SPEED TRIM

Allows manual speed trim of the engine (when enabled in the module configuration)

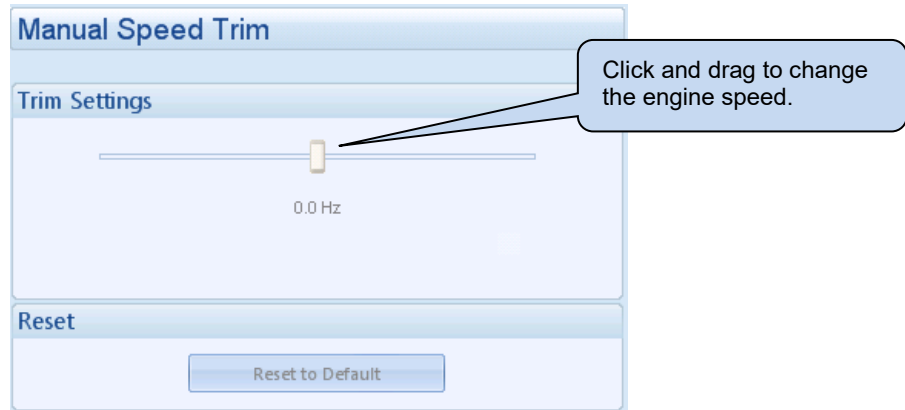

3.18.10 MODULE LOCK

Module Access Password

NOTE : If the PIN is lost or forgotten, it is no not possible to reset the module.

Allows a PIN (Personal Identification Number) to be set in the controller. This PIN must be entered to either access the front panel configuration editor or before a configuration file is sent to the controller from the PC software.

Module Configuration Write Password

Password

0

0

0

0

Confirmation

0

0

0

0

Warning - care should be taken when adjusting these controls.
 If the password is lost or forgotten, it will not be possible to access the module

Set PIN

By setting a 'module configuration Write password', it will restrict access to anyone without the pin being able to write to the module

Enter the desired PIN number and reconfirm.

Click to set the PIN number in the module.

Module Configuration Read Password

Password

0

0

0

0

Confirmation

0

0

0

0

Warning - care should be taken when adjusting these controls.
 If the password is lost or forgotten, it will not be possible to access the module

Set PIN

By setting a 'module configuration read password', it will restrict access to anyone without the pin being able to read from the module.

Enter the desired PIN number and reconfirm.

Click to set the PIN number in the module.

Accumulated Instrumentation Lock

NOTE: Enabling the *Accumulated Instrumentation Lock* option is **PERMANENT** and cannot be **REVERESED**. This is used to prevent tampering with the Accumulated Instrumentation such as Engine Hours. For further information, contact DSE Technical Support at Support@deepseaelectronics.com

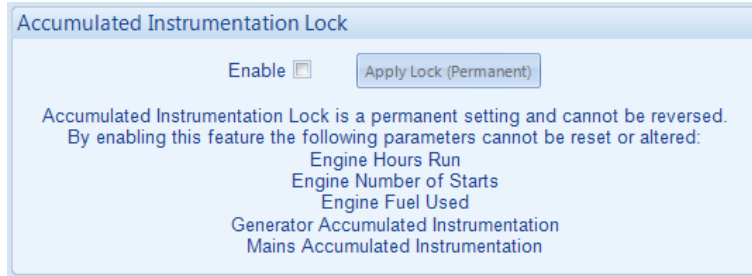

Parameter	Description
Accumulated Instrumentation Lock Enable	<p>NOTE: Enabling this option in the module's configuration locks the <i>Accumulated Instrumentations</i> permanently and it is not possible to disable it again through the configuration. For more information contact DSE Technical Support at Support@deepseaelectronics.com</p> <p>This feature is used to prevent the <i>Accumulated Instrumentation</i> being reset or edited by any means. The <i>Accumulated Instrumentation</i> consists of <i>Engine Run Hours</i>, <i>Number of Starts</i>, <i>Fuel Use</i>, <i>Generator kwh/kvarh/kvah</i>, and <i>Mains kwh/kvarh/kvah</i>.</p> <p><input type="checkbox"/> = The module does not lock its accumulated instrumentations, the <i>Apply Lock (permanent)</i> tab is greyed out.</p> <p><input checked="" type="checkbox"/> = The <i>Apply Lock (Permanent)</i> tab becomes visible.</p>
Apply Lock Permanent	<p>When pressing the <i>Apply Lock (Permanent)</i> button the below warning message to warn the user that this is a PERMANENT lock and once it is written to the module it cannot be changed.</p> <div style="border: 1px solid gray; padding: 5px; margin: 10px 0;"> <p>Warning</p> <p>Accumulated Instrumentation Lock is a permanent setting and cannot be reversed. By enabling this feature the following parameters cannot be reset or altered:</p> <ul style="list-style-type: none"> Engine Hours Run Engine Number of Starts Engine Fuel Used Generator Accumulated Instrumentation Mains Accumulated Instrumentation <p style="text-align: center;"><input type="button" value="OK"/></p> </div> <p>Upon pressing "OK", the module LOCKS all of its Accumulated Instrumentations (Engine Run Hours, Number of Starts, Generator kwh/kvarh/kvah, and Mains kwh/kvarh/kvah).</p> <p>When the module's Accumulated Instrumentations are locked, the Scada page changes to show the padlock icon indicating that the Accumulated Instrumentations are locked, the checkbox and the button are no longer available.</p> <div style="border: 1px solid gray; padding: 5px; margin: 10px 0;"> <p>Accumulated Instrumentation Lock</p> <p style="text-align: center;"> Module is LOCKED</p> <p>Accumulated Instrumentation Lock is a permanent setting and cannot be reversed. By enabling this feature the following parameters cannot be reset or altered:</p> <ul style="list-style-type: none"> Engine Hours Run Engine Number of Starts Engine Fuel Used Generator Accumulated Instrumentation Mains Accumulated Instrumentation </div>

3.19 DATA LOG

Allows viewing of the module data log (if configured).

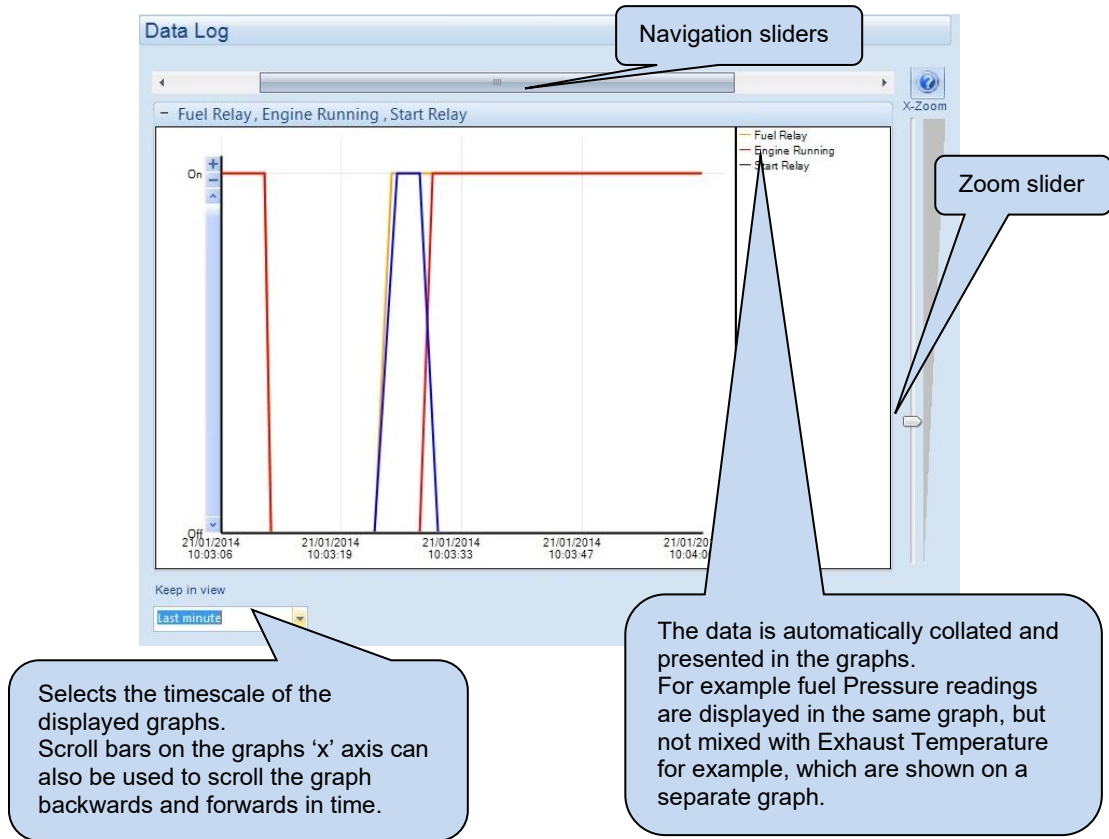

3.19.1 DATA LOG STATUS

Data Log Status	
Internal Memory Capacity	1024 kB
Remaining Data Log Memory	Space remaining in Internal memory: 1024 kB
Total Log Pages Available	3
Data Logging Status	Not Logging
Data Log Mode	Keep New
USB Drive Status	Not Fitted
Data Log Destination	Internal

3.20 PLC

NOTE: For further details and instructions on PLC Logic and PLC Functions, refer to the DSE PLC PROGRAMMING GUIDE, document part number 057-314

3.20.1 PLC LOGIC

Allows monitoring of the PLC functions within the controller.

3.20.2 PLC STORES

Allows the editing and setting of PLC Stores values.
Select the required section with the mouse.

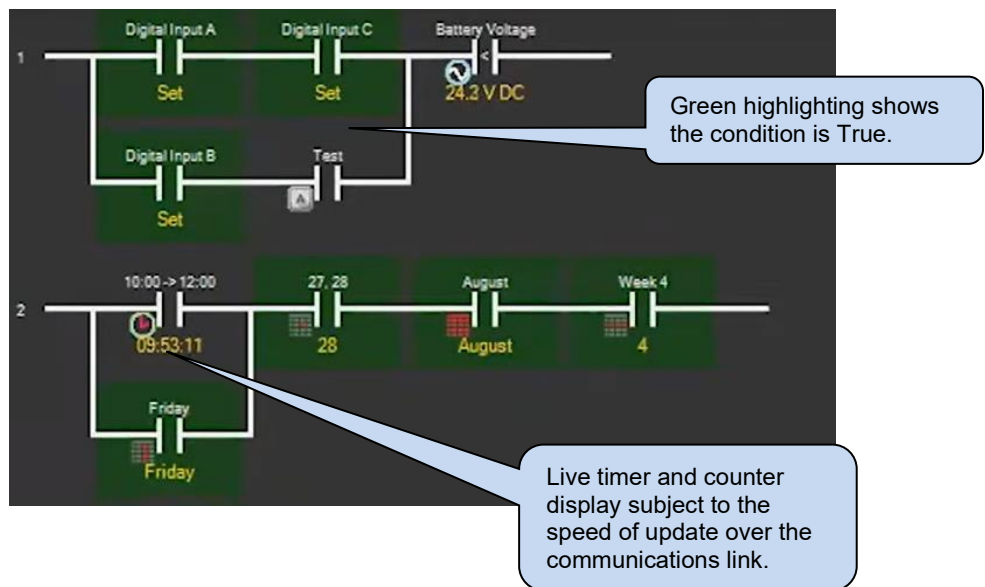

3.21 AVR

3.21.1 FREQUENCY, VOLTAGES AND CURRENT

Frequency, Voltages and Current	
Frequency	50.0 Hz
Feedback Voltage	120.0 V
Droop Current	0.00 A
Excitation Voltage	14.10 V
Auxiliary Voltage	178.9 V

3.21.2 DIAGNOSTICS

Diagnostics		
External Control		
Potentiometer +++	Voltage 0.02 V	
Set Points		
Voltage 120.0 V	Droop 3.0 %	UFRO Knee 42.7 Hz
Proportional 80.6	Integral 9.7	Derivative 50.0
Excitation Output		
Off Load Duty Cycle 8.0 %	Maximum Duty Cycle 100.0 %	
Soft Start		
Ramp Start Point (% of set point) 27.0 %	Ramp Rate (%/s) 30.0 %	

3.21.3 STATUS

Status

Software Version

1.0.11

Configuration

Active Configuration	Active Stability Configuration
0	1

3.21.4 CONTROL

Control

Set Points

Droop	3.0 %	<input type="range" value="3.0"/>	3.0 %
Proportional	80.6	<input type="range" value="80.6"/>	80.6
Integral	9.7	<input type="range" value="9.7"/>	9.7
Derivative	50.0	<input type="range" value="50.0"/>	50.0

Excitation Output

Off Load Duty Cycle	8.0 %	<input type="range" value="8.0"/>	8.0 %
Maximum Duty Cycle	100.0 %	<input type="range" value="100.0"/>	100.0 %

Soft Start

Ramp Start Point (% of set point)	27.0 %	<input type="range" value="27.0"/>	27.0 %
Ramp Rate (%/s)	30.0 %	<input type="range" value="30.0"/>	30.0 %

Configuration

Active Configuration	0	<input type="range" value="0"/>	0
Active Stability Configuration	1	<input type="range" value="1"/>	1

3.21.5 AVR ALARMS

AVR Alarms

AVR Alarms

Start-up failed trip

3.22 EXPANSION

Select the required section with the mouse.

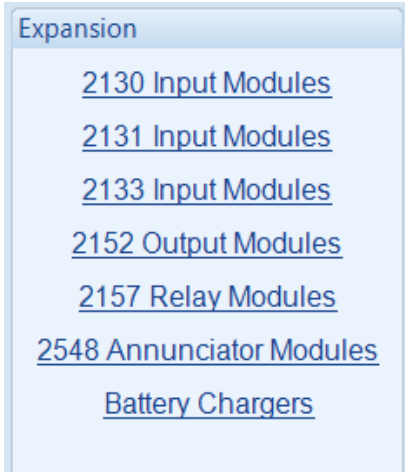

Allows monitoring of the controller's expansion modules (when fitted)

For example:

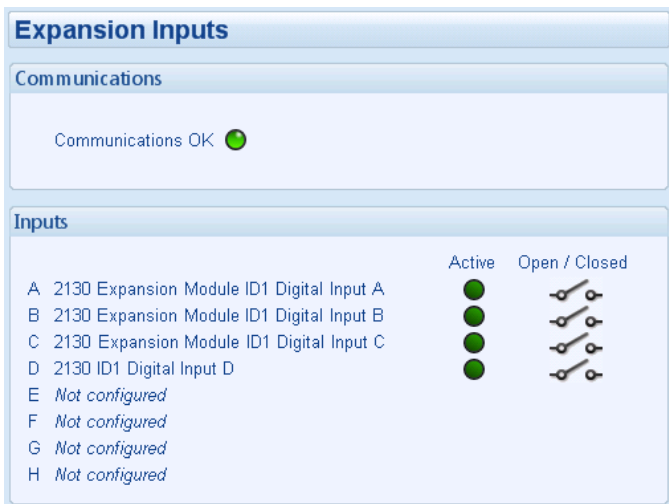

4 ALARM TYPES

The protection included with the DSE control modules provides increasing levels of notification, depending upon the severity of the situation:

Alarm type	Description
Indication	No audible alarm or common warning signal occurs. <i>Indication</i> alarms are only used to illuminate indicators or to activate outputs.
Warning	Audible alarm and common alarm signal is generated. The set continues to run. <i>Warning</i> alarms are used to draw the operator's attention to a minor issue or to a problem that may escalate to an Electrical Trip or Shutdown Alarm if left untreated.
Electrical Trip	Audible alarm and common alarm signal is generated. The set is taken off load and the cooling timer begins, after which the set is stopped. <i>Electrical Trip</i> alarms are series issues that require the set to be taken off load. As the name implies, this is often electrical faults that occur 'after' the load switch. The set is allowed to cool before stopping.
Shutdown	Audible alarm and common alarm signal is generated. The set is taken off load and immediately stopped. <i>Shutdown</i> alarms are serious issues that demand immediate stopping of the generator. For instance Emergency Stop or Overspeed alarms require immediate shutdown.

5 ALARM ARMING

The protections on the DSE module are active during their configured *Alarm Arming* setting. The table below shows the timing segment for the different *Alarm Arming* options with regards to the generator status.

Timing Segment	Stopped	Start Delay	Preheat	Cranking	Safety Delay	Smoke Limiting	Smoke Limiting Off	Warming Up	Gen Available/ Gen On Load	Cooling	Cooling in Idle
Always											
From Starting											
From Safety On											
Engine Protection											
Over frequency / Overspeed / Overshoot											
Loading Alarms											

5.1 ALWAYS

The protection is always active on the controller. This is used to constantly monitor statuses such as a fuel level switch irrespective of the engine running state.

5.2 FROM STARTING

The protection is active from the beginning of engine cranking, until the engine stops.

5.3 FROM SAFETY ON

The protection is active when the set is running at nominal speed, until the engine stops.

5.4 ENGINE PROTECTION

The protection is active when the engine is running and all engine protection (for example oil pressure and coolant temperature) are in a 'healthy' state.

Oil Pressure Warning

Oil Pressure Shutdown

Oil Pressure Open Circuit (CANbus engine)

High Coolant Temperature Warning

High Coolant Temperature Shutdown

High Coolant Temperature Electrical Trip

High Coolant Temperature Open circuit (CANbus engine)

CAN ECU Warning

CAN ECU Shutdown

Generator Phase Rotation Shutdown

5.5 OVERSHOOT

Active during the *Safety Delay* timer, this allows for a temporary raise of the overspeed/over frequency trip points during start-up.

Protection Level	Over Frequency Trip Level	Over Speed Trip Level
Immediate Shutdown	Over Frequency + Overshoot %	Over Speed + Overshoot %
Delayed Shutdown (Overspeed Overshoot Delay)	Over Frequency	Over Speed

Example

57 Hz *Over Frequency* setting, 10% *Overspeed Overshoot*

During *Safety Delay* a generator frequency above $(57 \text{ Hz} \times 1.1) = 62.7 \text{ Hz}$ results in an immediate shutdown without delay.

After *Safety delay*, a generator frequency above 57 Hz for the period of the *Generator Transient Delay* results in a shutdown.

5.6 LOADING ALARMS

This alarm is active after the generator runs, and the voltage and frequency are above their Loading levels, until the generator stops.

This Page Intentionally Blank